

## NOTE:

This brochure contains IMPORTANT safety info. Please read and keep for future reference.

# MAINTAINANCE AND WARNING

- 1.Keep furniture away from heat sources.
- 2.Do not clean furniture with harsh cleaner or polishes.Do not use detergents,solvents,abrasives,spray packs or leather cleaner. Use non-color mild soa with warm water to clean spills(Mix 1:10 soap to water).
- 3.Do not place furniture under direct sunlight,material will possibly fade over time.
- 4.Do not use on site dry cleaning machine.Children should not climb or jump on the furniture.
- 5.Do not write on furniture that is not protectedby a padded barrier.
- 6.Not for commercial use,only for residential use.



# PARTS LIST

## A BOX

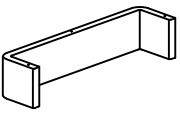
A	X2
	
Headboard	

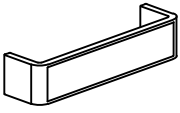
B	X1
	
Bench	

## B BOX

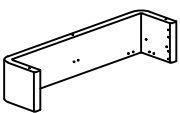
C	X2
	
Footboard	

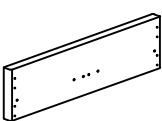
D	X2
	
Sideboard	

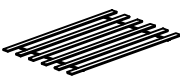
E	X2
	
Slat	

F	X4
	
Side rail	

G	X1
	
Long structure	

H	X2
	
Short structure	

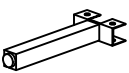
J	X1
	
Middle leg	

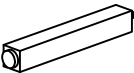
K	X4
	
Side leg	

2 PERSONEN

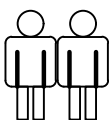



## HARDWARE LIST

L	X9
	
Metal bar	
5/16**80mm	

M	X8
	
Metal plate	

N	X4
	
Corner bracket	

O	X4
	
Leg	

P	X8
	
Nut	
5/16"	

Q	X80
	
Spring washer	

R	X80
	
Flat washer	

S	X18
	
Bolt	
5/16**50mm	

T	X56
	
Bolt	
5/16**25mm	

W	X9
	
Screw cover sticker	
38*28mm	

## TOOL LIST

U	X1
	
Allen key	
5mm	

V	X1
	
Open wrench	
5/16"	

## HARDWARE SPARE LIST

P	X1
	
Nut	
5/16"	

Q	X6
	
Spring washer	

R	X6
	
Flat washer	

S	X1
	
Bolt	
5/16**50mm	

T	X3
	
Bolt	
5/16**25mm	

# ASSEMBLY INSTRUCTIONS

## STEP-1

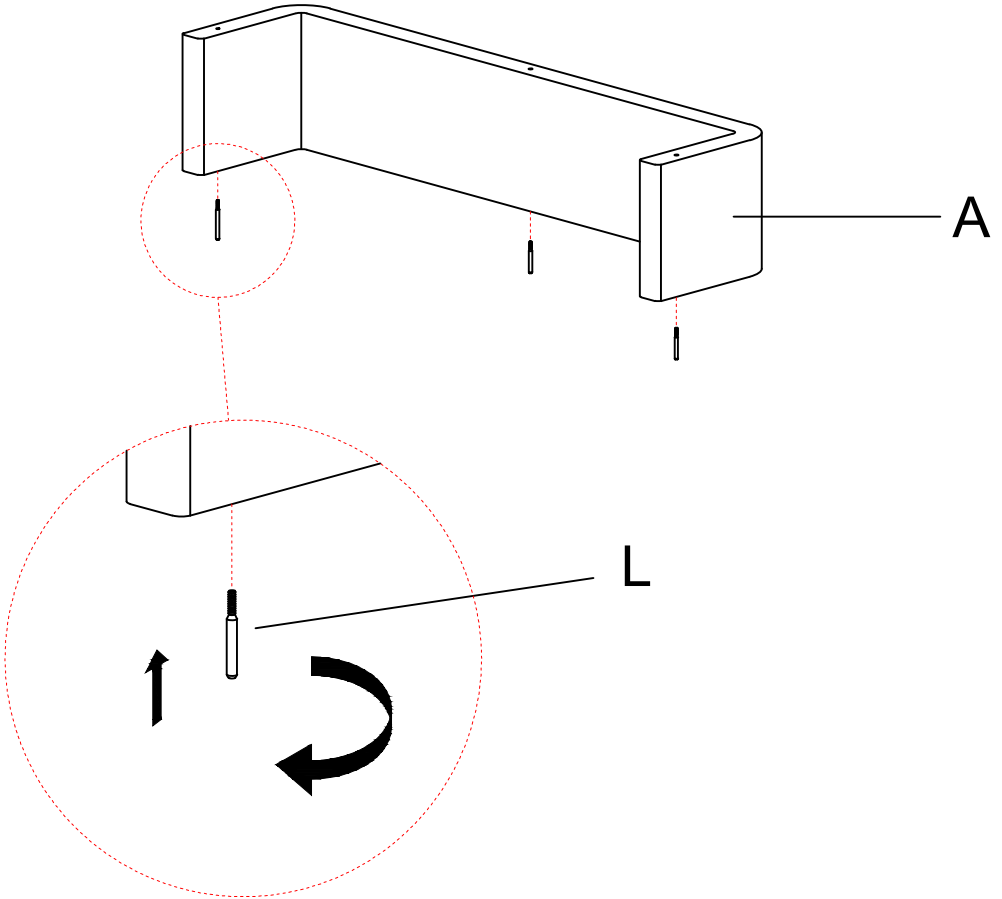



L	X3
	
Metal bar	
5/16**80mm	

# ASSEMBLY INSTRUCTIONS

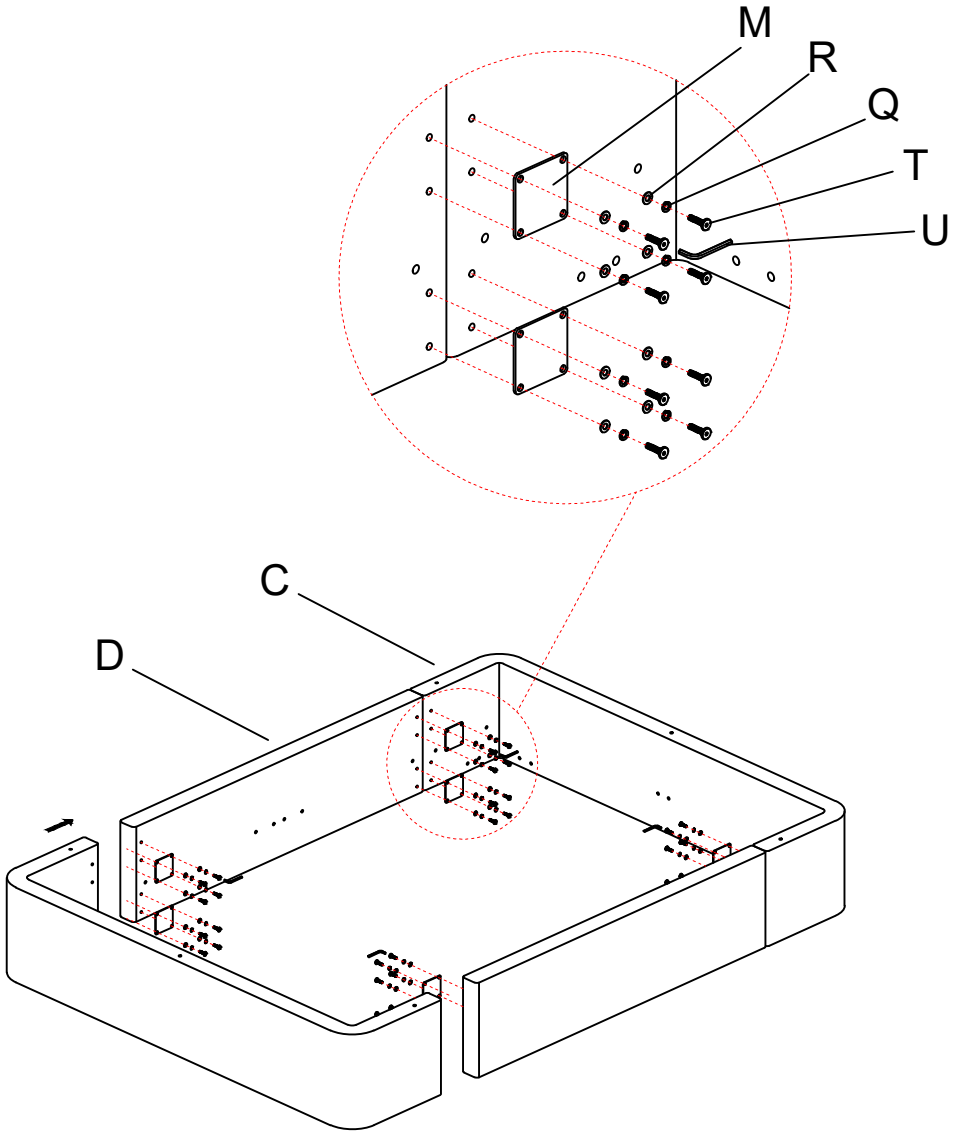
## STEP-2



M	X8
	
Metal plate	

Q	X32
	
Spring washer	

R	X32
	
Flat washer	

T	X32
	
Bolt	
5/16"*25mm	

U	X1
	
Allen key	
5mm	

# ASSEMBLY INSTRUCTIONS

## STEP-3

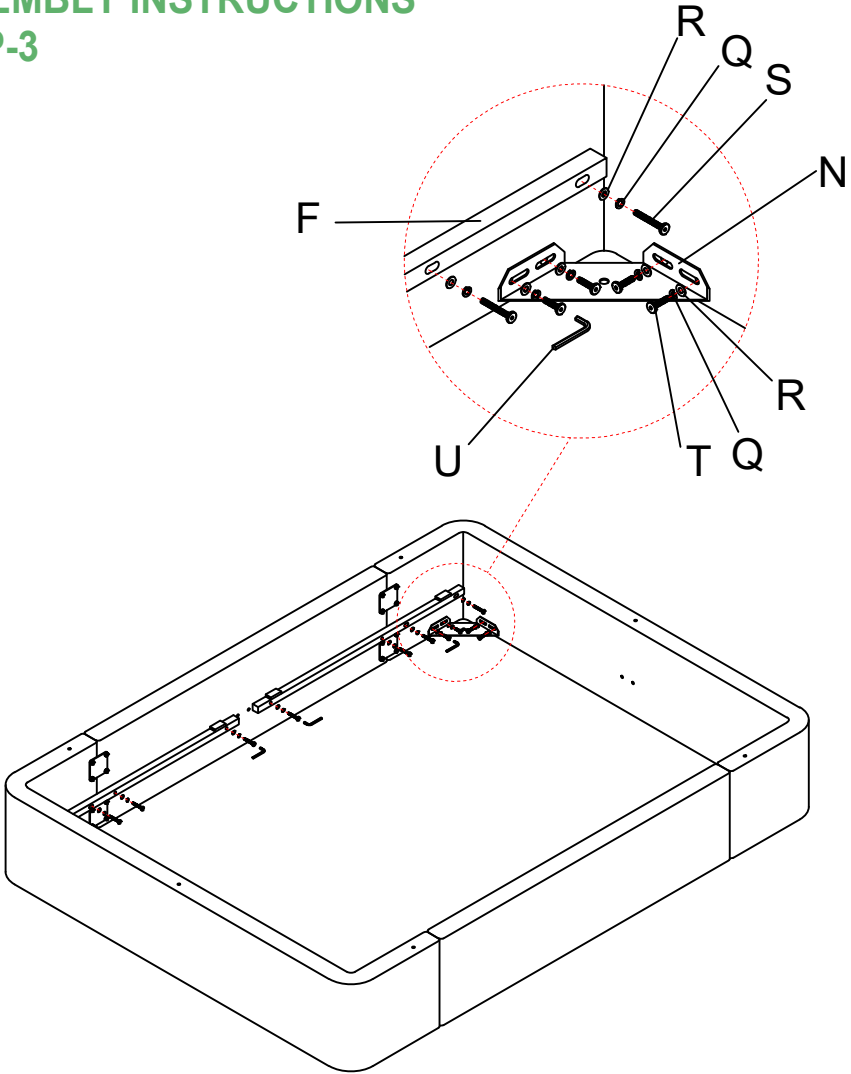

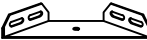

N	X4
	
Corner bracket	

Q	X32
	
Spring washer	

R	X32
	
Flat washer	

S	X16
	
Bolt	
5/16**50mm	

U	X1
	
Allen key	
5mm	

T	X16
	
Bolt	
5/16**25mm	

# ASSEMBLY INSTRUCTIONS

## STEP-4

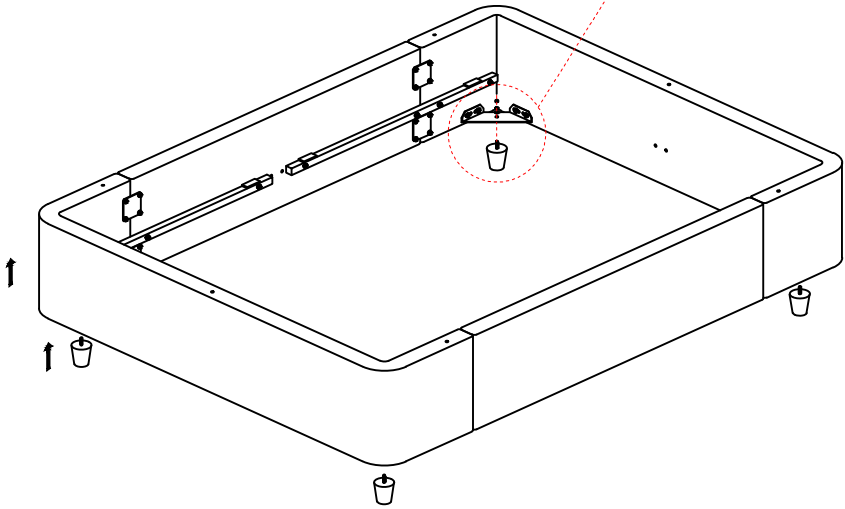
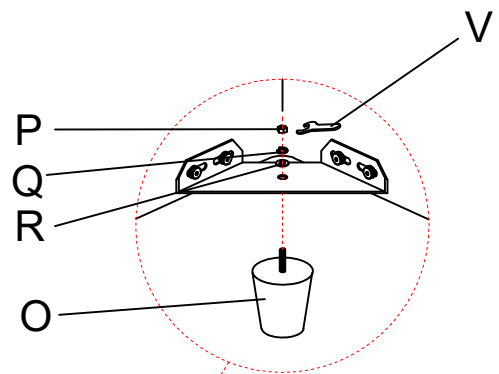
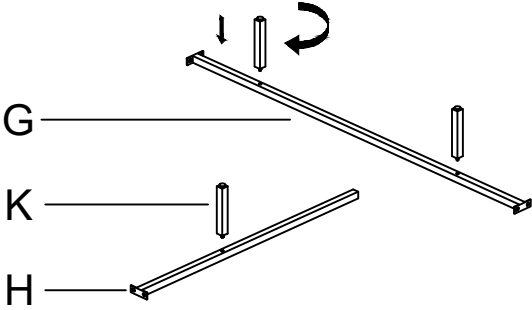

O	X4
	
Leg	

P	X4
	
Nut	
5/16"	

Q	X4
	
Spring washer	

R	X4
	
Flat washer	

V	X1
	
Open wrench	
5/16"	

# ASSEMBLY INSTRUCTIONS

## STEP-5

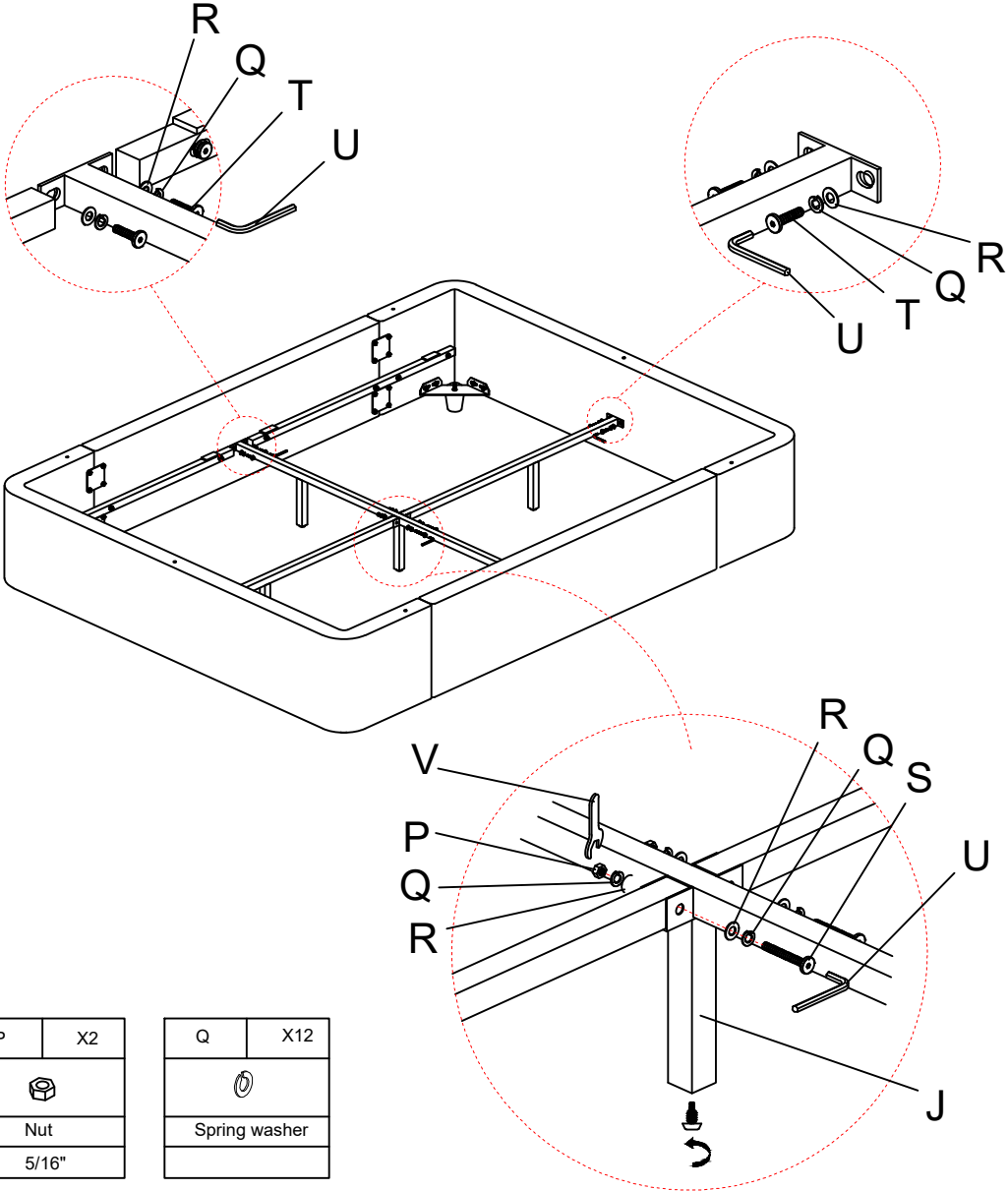



P	X2
	
Nut	
5/16"	

Q	X12
	
Spring washer	

R	X12
	
Flat washer	

T	X8
	
Bolt	
5/16"*25mm	

S	X2
	
Bolt	
5/16"*50mm	

U	X1
	
Allen key	
5mm	

V	X1
	
Open wrench	
5/16"	

# ASSEMBLY INSTRUCTIONS

## STEP-6

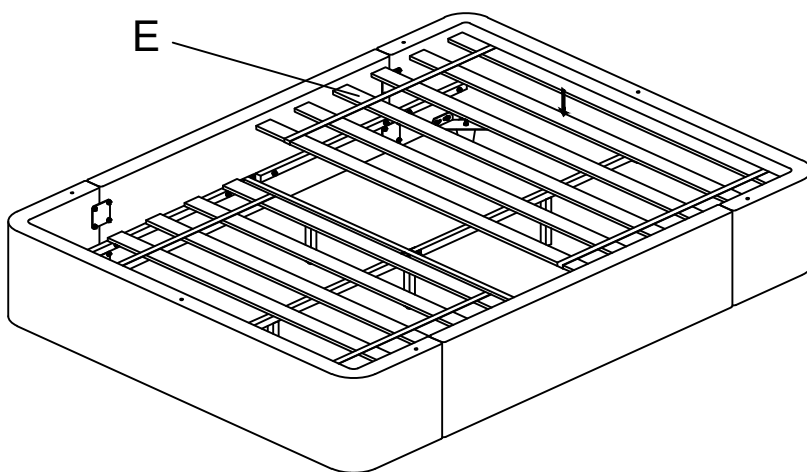

# ASSEMBLY INSTRUCTIONS

## STEP-7

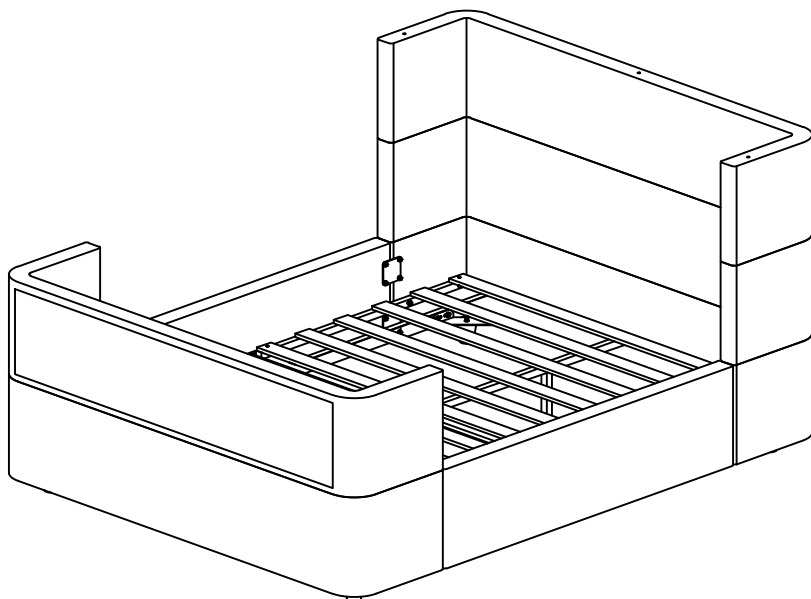
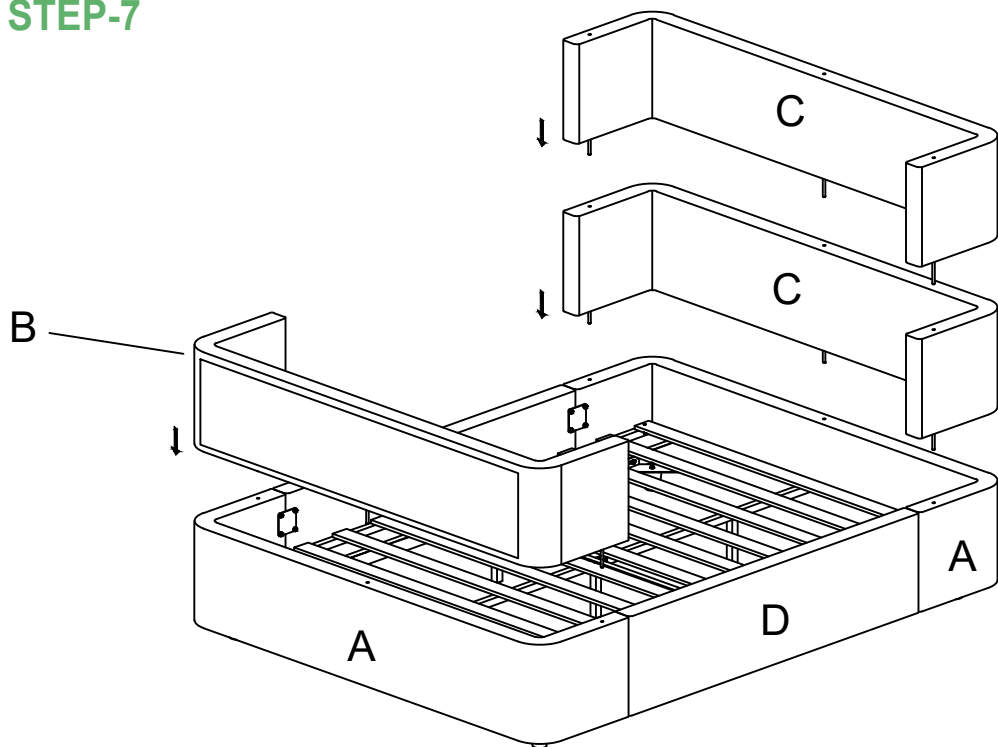

# ASSEMBLY INSTRUCTIONS

## STEP-8

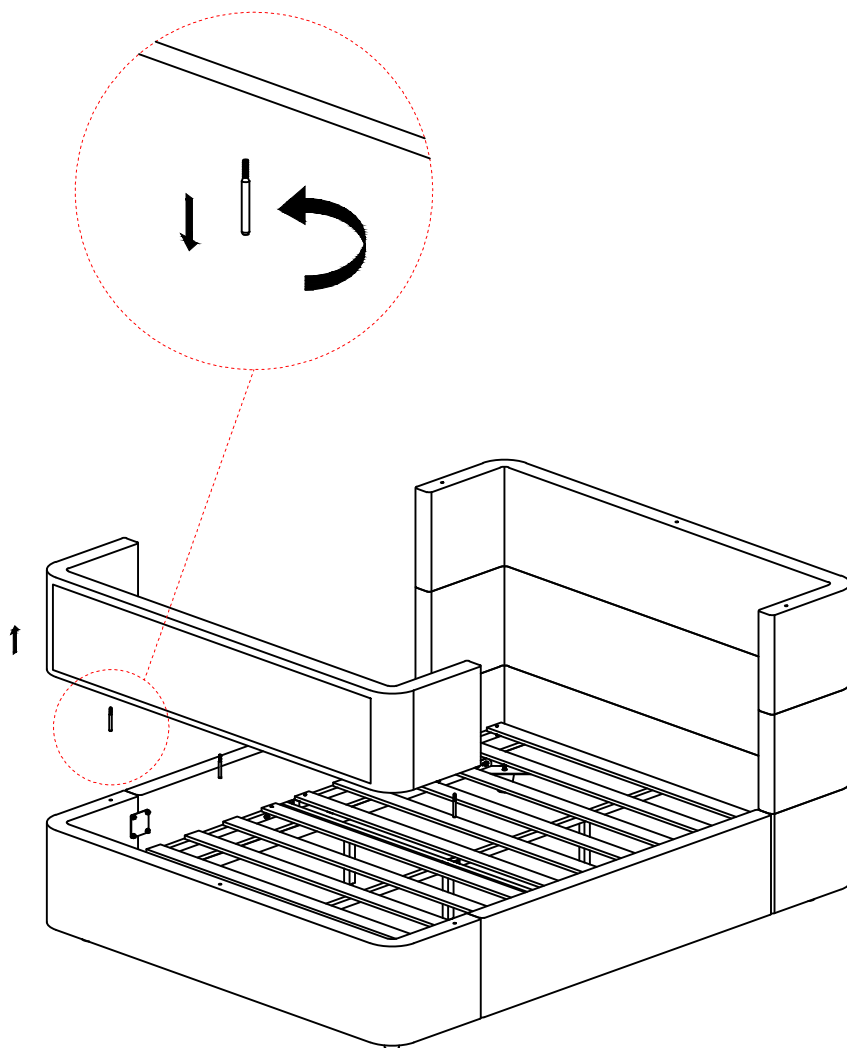

# ASSEMBLY INSTRUCTIONS

## STEP-9

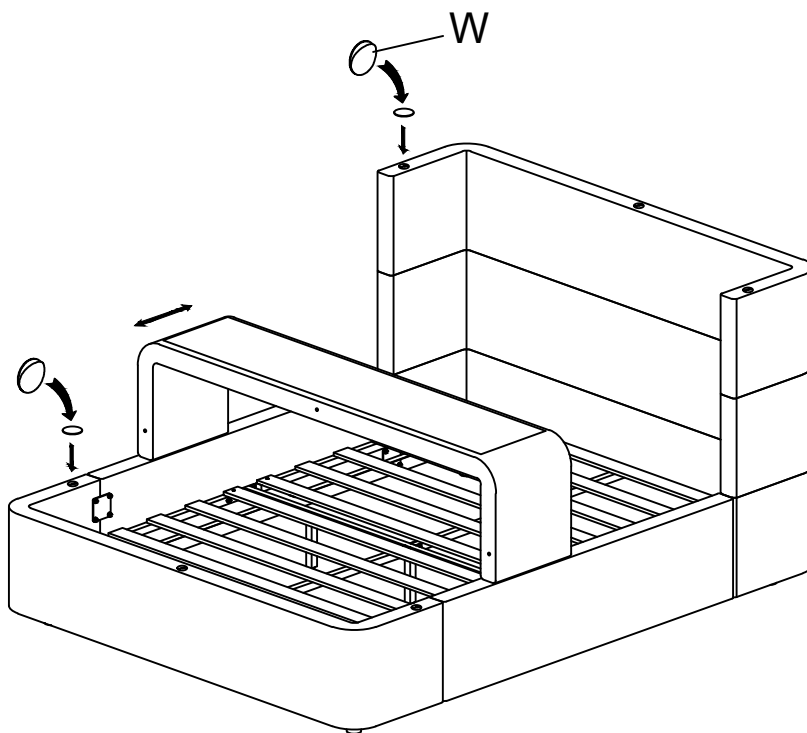

W	X9
	
Screw cover sticker	
38*28mm	

# WARRANTY

1. We strive to offer high-quality products, and we also try our best to satisfy each and every customer that orders from us with product or service as needed.
2. We provide 30 days warranty starting from the time you receive the item. Each customer must provide a record of their order such as the order number, or item receipt for any items that are out of the warranty period you may also still receive.
3. Replacement parts by purchasing them with our company if they are available.

Are you having difficulty  
With assembly? Missing parts?

For return, please check the return policy with  
the retailer or market place you bought from.

Appreciate your purchasing from us.  
Pop up your life by our furniture piece!