

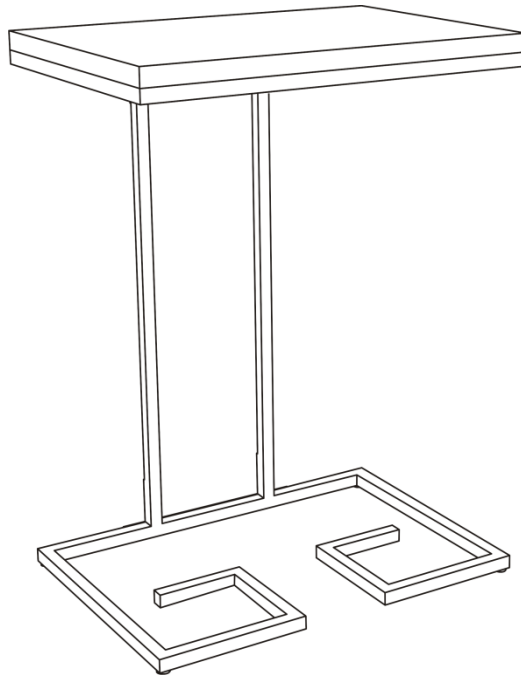

Assembly Instructions

Caution: You must read this before you proceed

End Table





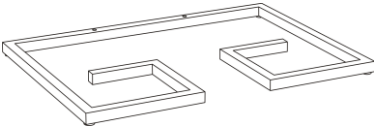
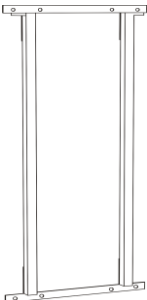

Part List

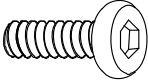
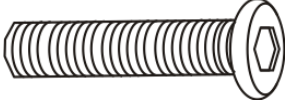
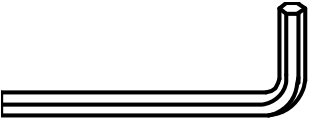
Label	Picture	Description	QTY
A		Table Top	1
B		Support Bar	1
C		Leg	1

Hardware

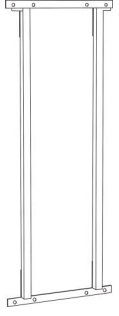
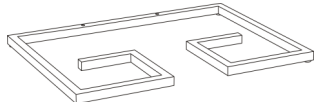
Label	Picture	Description	QTY
①		Washer	14
②		Bolt (M6*20mm)	11
③		Bolt (M6*30mm)	3
④		Allen Key	1

Assembly Preparation

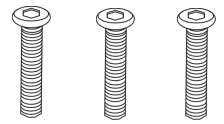
<p>Before Beginning Assembly:</p>	  	  *11  *14	
-----------------------------------	---	---	---



- Read instructions, cover to cover-



- Have 2 adults on hand for assembly-



- Do not assemble on flooring or carpet-



- Assemble on a clean non-marring surface (packing foam)-



- Save all packaging until finished-

Assembly Steps

Overview

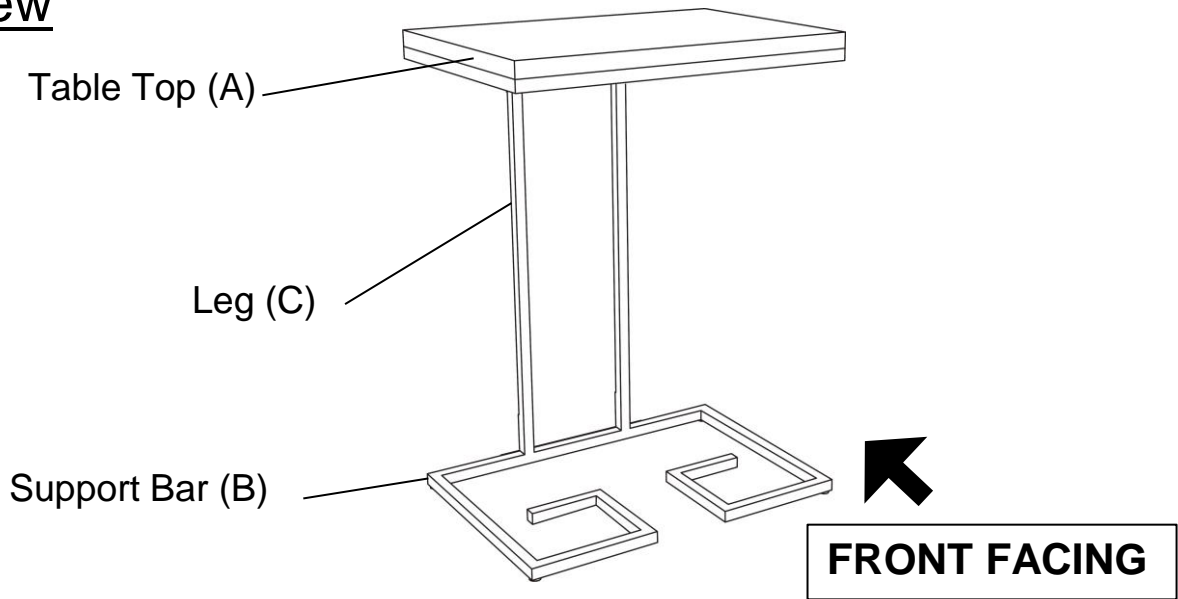

This Table has multiple parts and may require up to 30 minutes to assemble. To give you an overview of the Table parts, the above picture is to help you put the various parts into perspective. Please read through the instructions below to familiarise yourself with the parts and steps before assembly.

Step 1

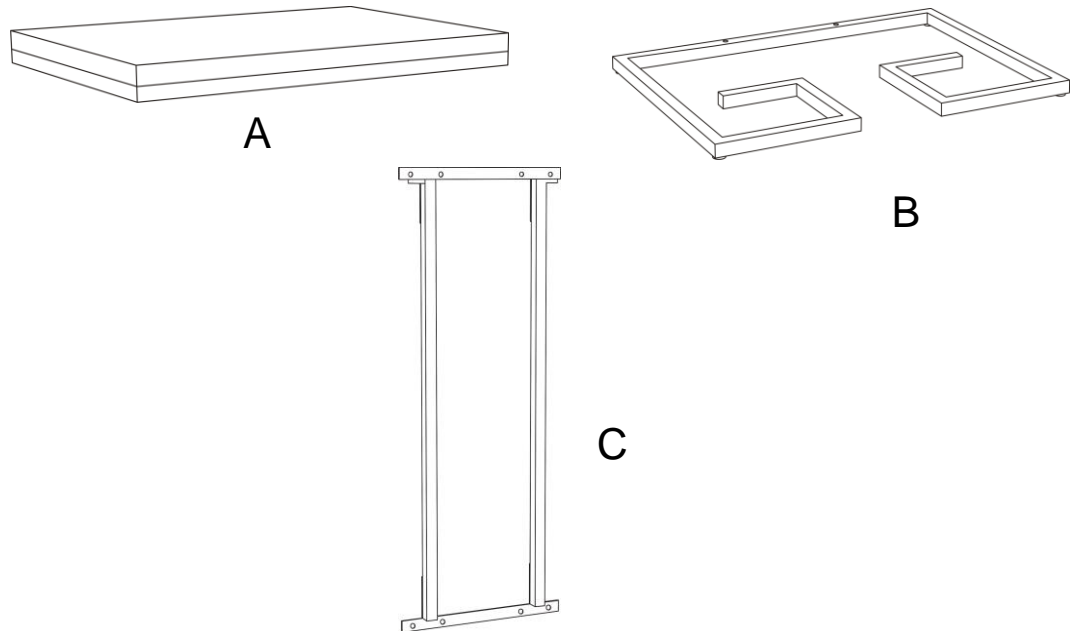

Open the carton and place all the parts onto a clean, non-marring surface.

Step 2

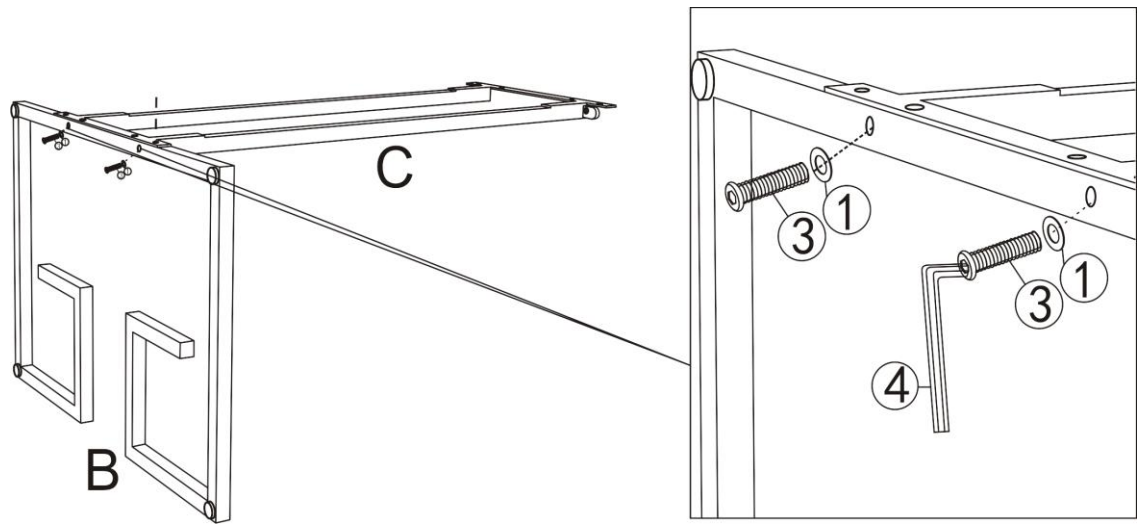

Align the mounting positions on the Support Bar(B) and the Leg(C), then attach using Washers(①) and Bolts(③) with Allen Key(④) as shown.

Do not fully tighten the Bolts.

Step 3

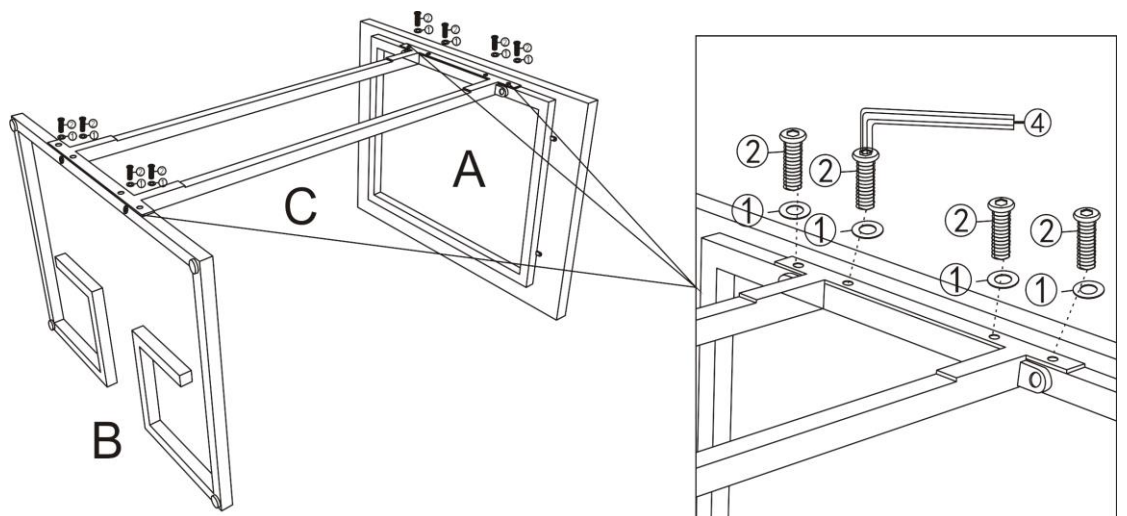

Attach Leg(C) to Support Bar(B) using Washers(①) and Bolts(②) with Allen Key(④) as shown.

Align the mounting positions on the Table Top(A) and Leg(C), then attach using Washers(①) and Bolts(②) with Allen Key(④) as shown.

Do not fully tighten the Bolts.

Step 4

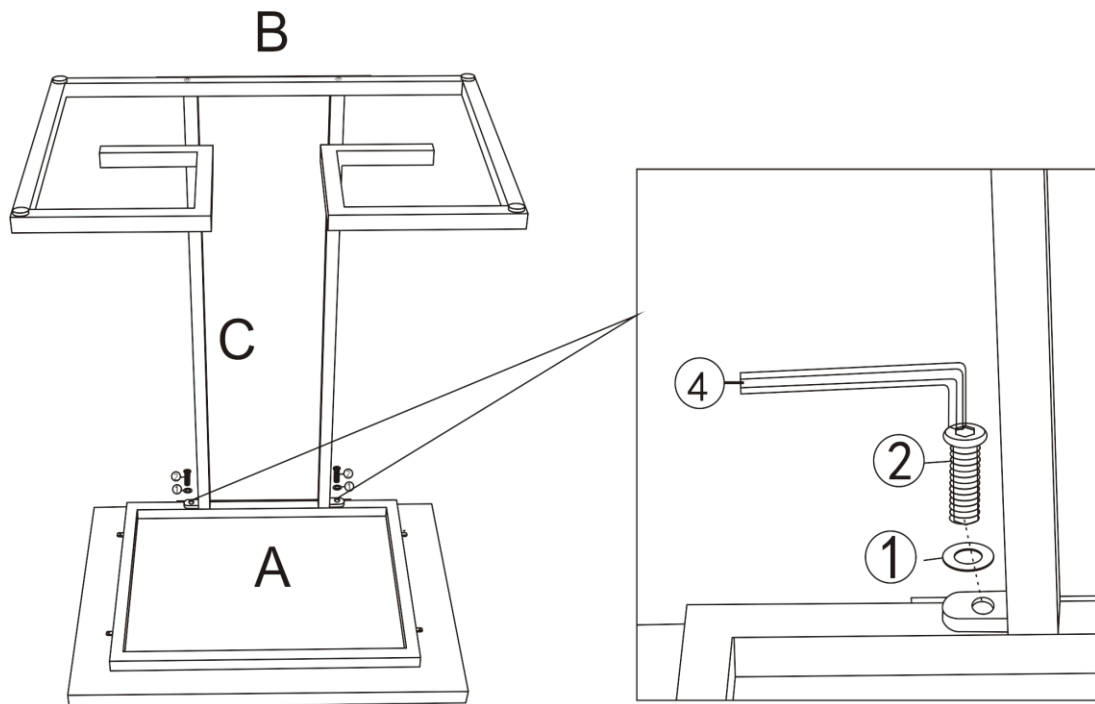

Attach Leg(C) to Table Top(A) using Washers(①) and Bolts(②) with Allen Key(④) as shown.

Step 5

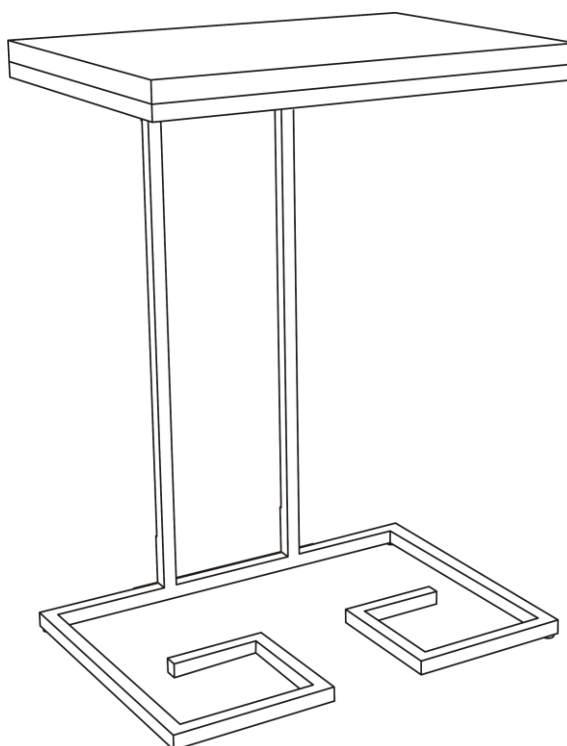











In a sequential manner fully tighten all Bolts at all joints.

Your End Table is now ready to for use.

This End Table can only be used on a flat, level surface.

Care & Maintenance

-  Do not put hot items directly on furniture surface
 -  Do not clean furniture with harsh cleansers or polish.
 -  Do not place furniture under direct sunlight.
 -  Do not place furniture near heating or cooling vents.
 -  Do not write on furniture without a padded barrier to protect the surface.
 -  Do not place furniture outside . For indoor use only .
 -  Not for commercial use. For residential use only .
 -  Stains may be removed with mild soap solution and damp cloth.
 -  Children should not climb or jump on the furniture.
-
-  Dust and pick-up spills using a clean, non-colored, lint-free cloth .