

ASSEMBLY INSTRUCTIONS

LT with 1Dr and shelves

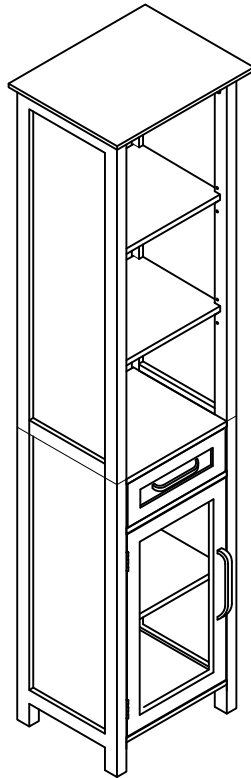

Please provide the following information when contacting for parts or questions: the name of the company you purchased from, the tracking number of the original package, and the original order date.

We offer free replacements (purchase verification required). This replacement policy does not cover used/previously returned product or products sold by unauthorized third party vendors.

ASSEMBLY INSTRUCTIONS-IMPORTANT

Carefully unpack & identify each component before attempting to assemble. Refer to parts list. Please take care when assembling the unit and always set the parts on a clean, soft surface.

INSTRUCCIONES PARA ARMAR-IMPORANT:







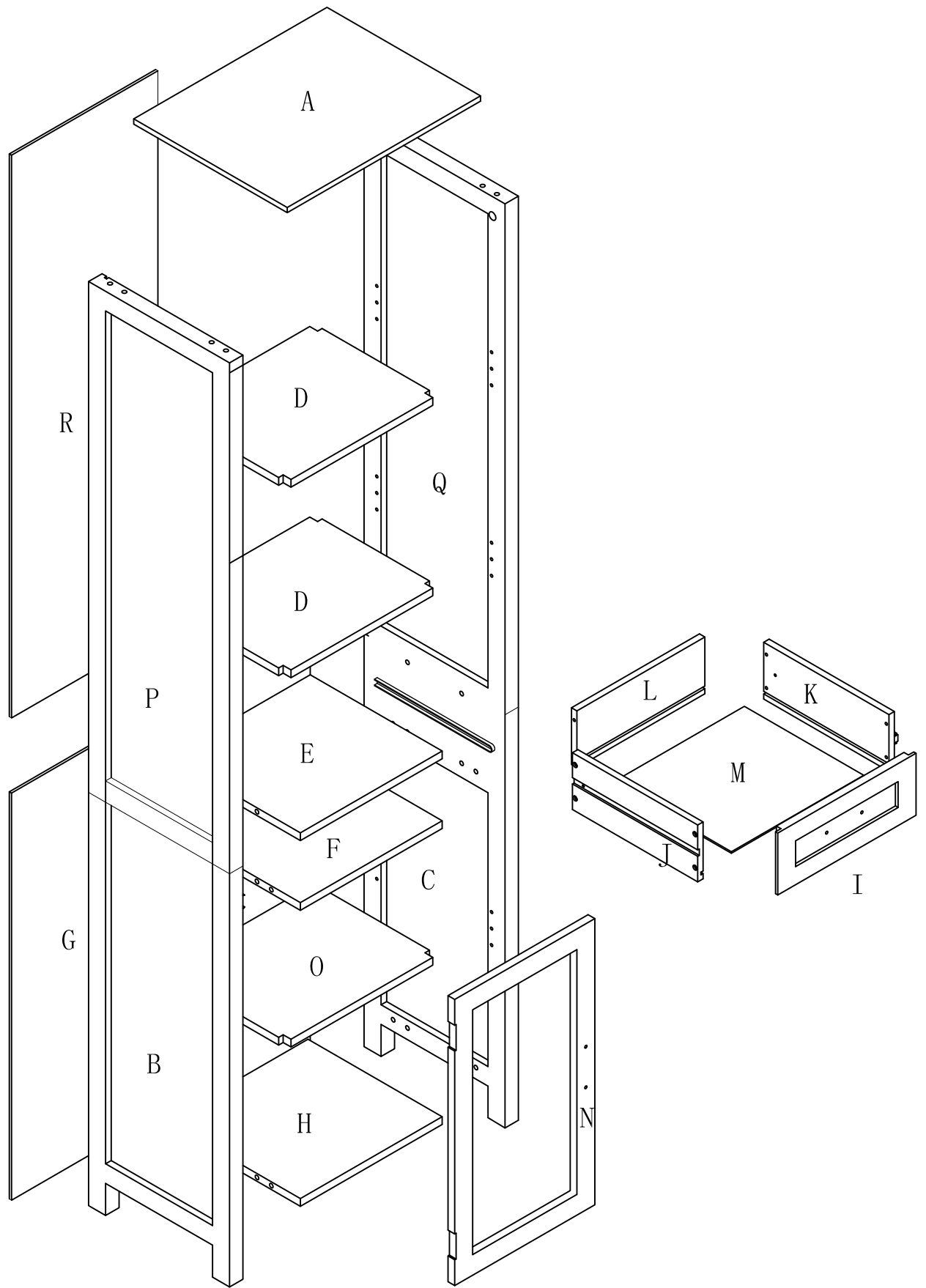





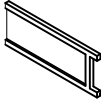

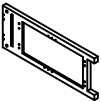

Desempaque cuidadosamente e identifique cada componente antes de tartar de empezar su ensambladura. Verifique la lista de partes. Por favor tenga cuidado cuando arme la unidad y siempre coloque las piezas sobre una superficie plana, suave y limpia.

DIRECTIVES DE MONTAGE-IMPORTANT:

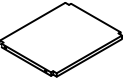

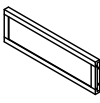

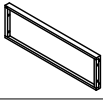





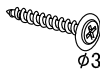
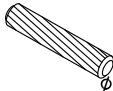

Avant de commencer l' assemblage, déballez délicatement toutes les pièces et repérez-les sur la liste des pièces. Procédez avec soins durant l' assemblage et posez toujours les pièces sur une surface proper, douce et lisse.



COMPONENTS

PART	FIGURE	DESCRIPTION	QTY	PART	FIGURE	DESCRIPTION	QTY
A		TOP PANEL	1PC	J		DRAWER LEFT SIDE PANEL	1PC
B		BOTTOM LEFT SIDE PANEL	1PC	K		DRAWER RIGHT SIDE PANEL	1PC
C		BOTTOM RIGHT SIDE PANEL	1PC	L		DRAWER BACK PANEL	1PC
D		UPPER ADJUSTABLE SHELF	2PCS	M		DRAWER BOTTOM PANEL	1PC
E		MIDDLE FIXED SHELF	1PC	N		DOOR	1PC
F		DRAWER FIXED SHELF	1PC	O		BOTTOM ADJUSTABLE SHELF	1PC
G		BOTTOM BACK PANEL	1PC	P		UPPER LEFT SIDE PANEL	1PC
H		BOTTOM PANEL	1PC	Q		UPPER RIGHT SIDE PANEL	1PC
I		DRAWER FACE PANEL	1PC	R		UPPER BACK PANEL	1PC

HARDWARE & TOOLS

PART	FIGURE	DESCRIPTION	QTY	PART	FIGURE	DESCRIPTION	QTY
1		CAM LOCK	20PCS	9		SHELF PIN	12PCS
2		CAM BOLT	20PCS	10	 ø3*12 D=7	SCREW	24PCS
3	 ø8*30	WOODEN DOWEL	20PCS	12		FIX BELT	1PC
4	 ø4*25	SCREW	8PCS	13	 ø4*25	SCREW	2PCS
5	 ø3*12	SCREW	4PCS	14		ANCHOR	1PC
6		HANDLE	2PCS	15		CAM COVER	1PC
7		BOLT	4PCS	16		DRAWER STOPPER	2PCS
8		WASHER	2PCS				

TOOL NEEDED:



**PHILIPS SCREWDRIVER REQUIRED
- NOT INCLUDED**

SUGGESTION:



TWO PEOPLE FOR ASSEMBLING



WARNINGS:

1. DO NOT LET ANY SHARP OBJECTS TOUCH OR RUB THE SURFACE OF THE PRODUCT.
2. WHEN ASSEMBLING, DO NOT LET CHILDREN PLAY AROUND THE WORKING AREA.
3. PLEASE CONFIRM ALL PARTS ARE CORRECT BEFORE STARTING THE ASSEMBLY PROCESS.
4. DO NOT TIGHTEN ALL BOLTS AND SCREWS COMPLETELY UNTIL THE ENTIRE UNIT HAS BEEN ASSEMBLED AND SET UP.

1

1



6 PCS

2



12 PCS

3



12 PCS

15



6 PCS

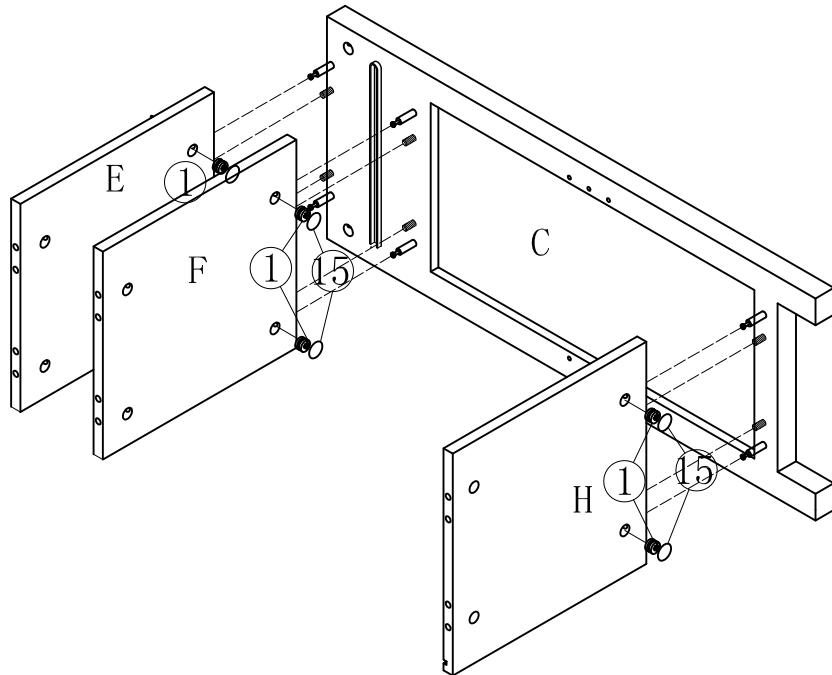
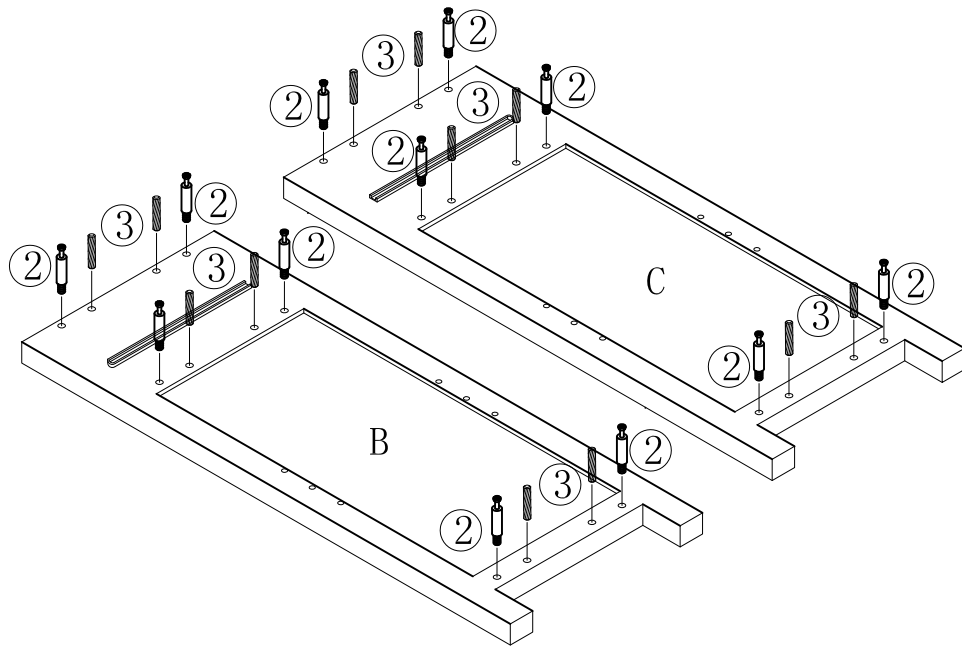

STEP 1:

1. Screw cambolts (2) and insert dowels (3) in panels B & C.
2. Attach panels E, F & H to panel C and secure with camlocks (1).

2

1



6 PCS

3



4 PCS

2



4 PCS

15



6 PCS

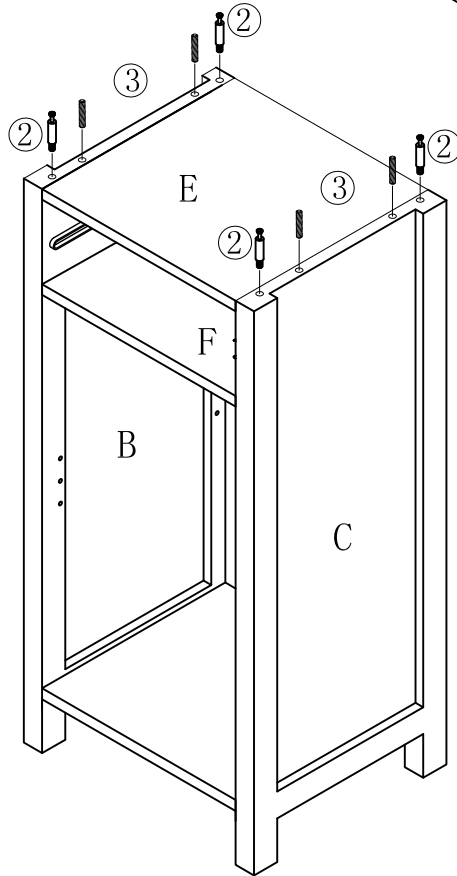
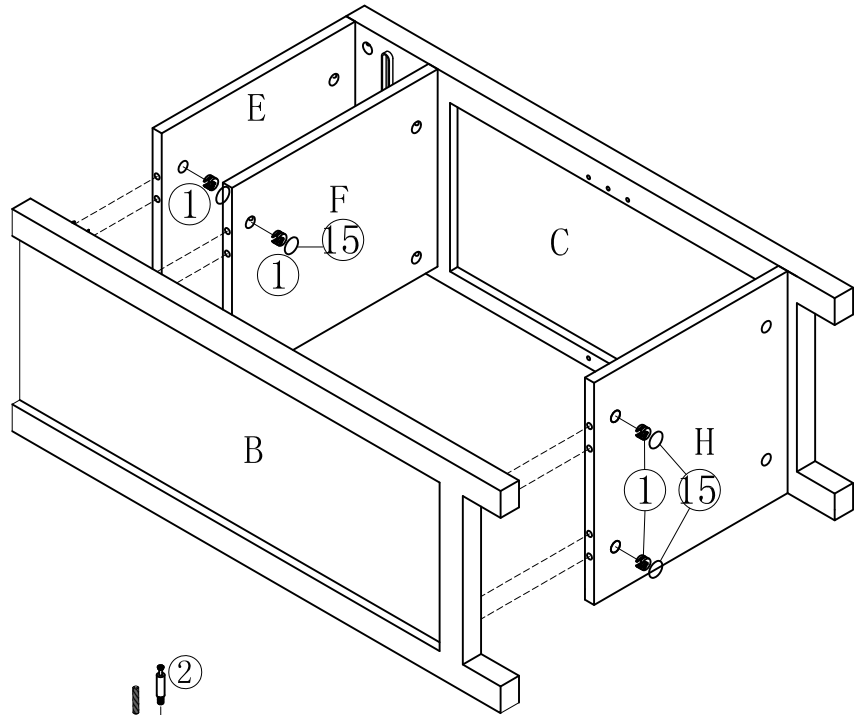

STEP 2:

1. Attach panel B to panels E, F, & H and secure with camlocks (1).
2. Screw cambolts (2) and insert dowels (3) to the tops of panels B & C.

3

1



4 PCS

15



4 PCS

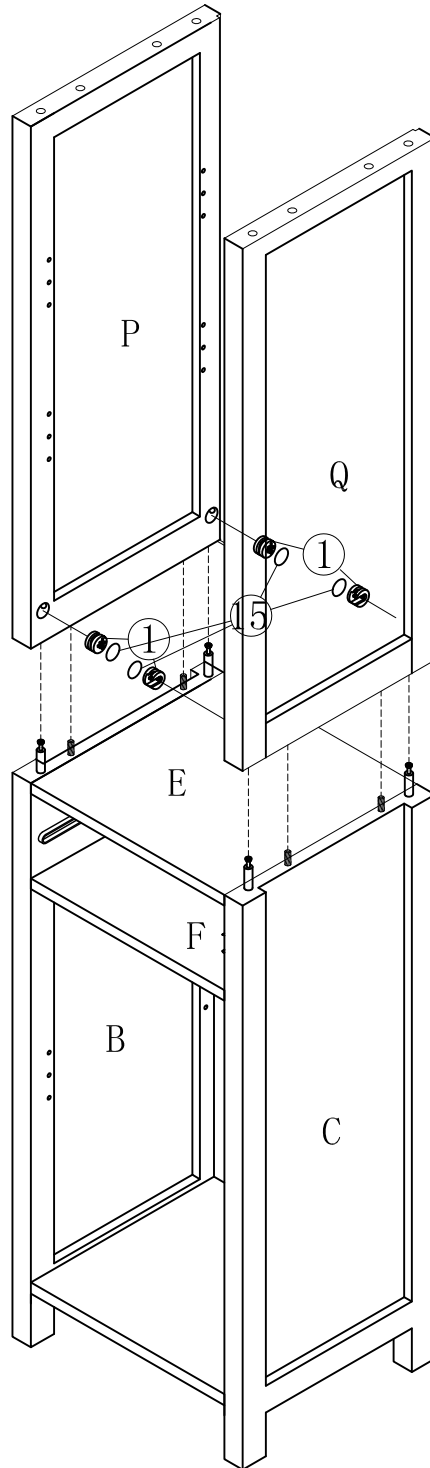

STEP 3:

1. Attach panels P & Q to the tops of panels B & C and secure with camlocks (1).

4

2



4 PCS

3



4 PCS

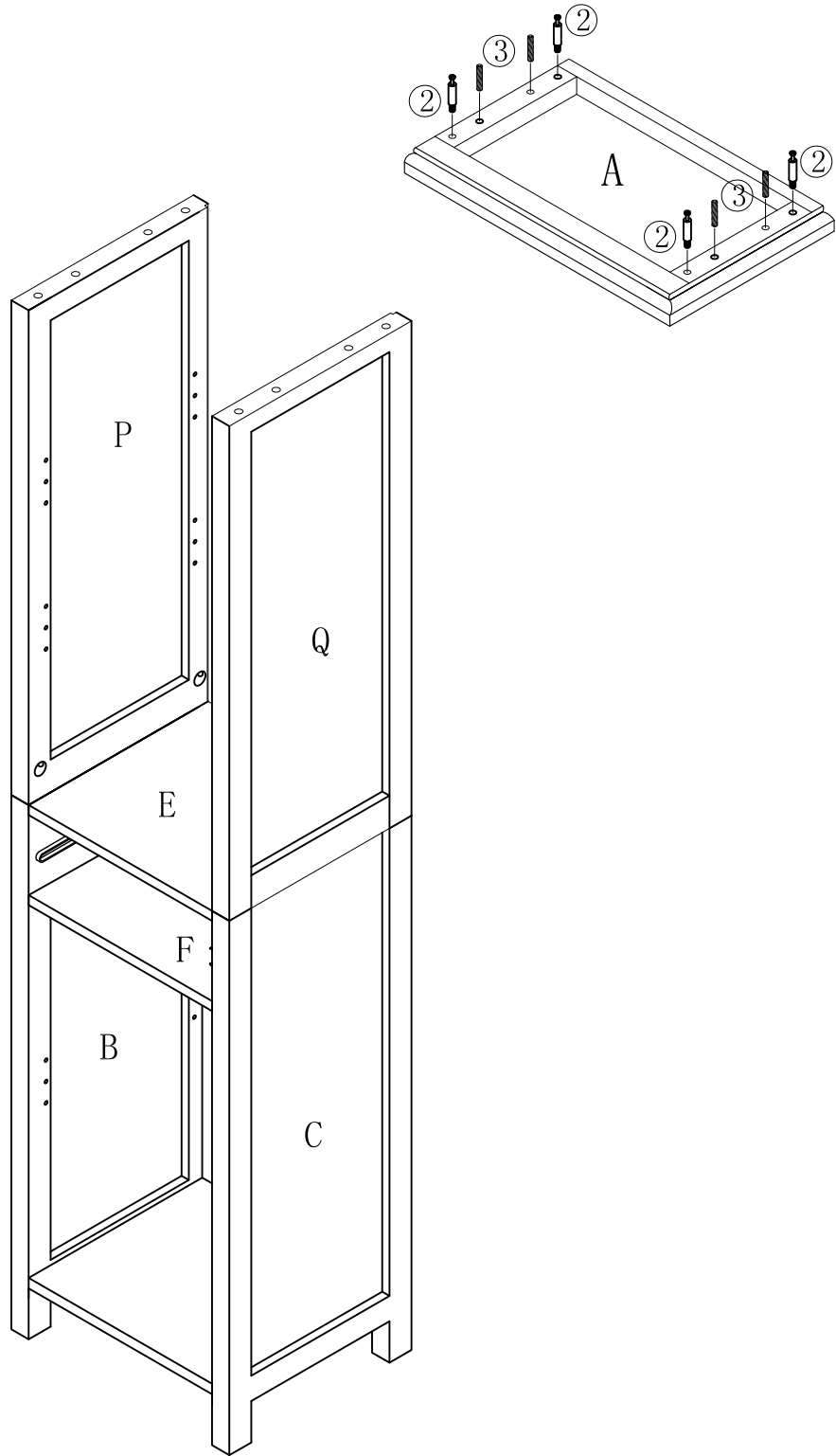

STEP 4:

1. Screw cambolts (2) and insert dowels (3) in panel A.

5

1



4 PCS

15



4 PCS

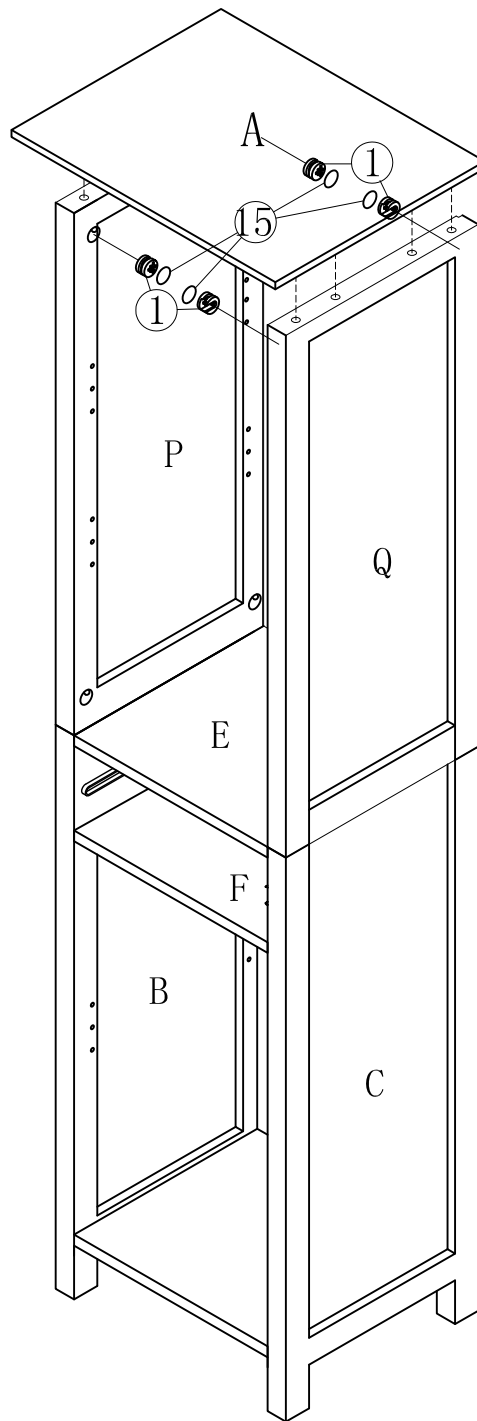

STEP 5:

1. Attach panel A to panels P & Q and secure with camlocks (1).

6

10



24 PCS $\phi 3 \times 12$ D=7

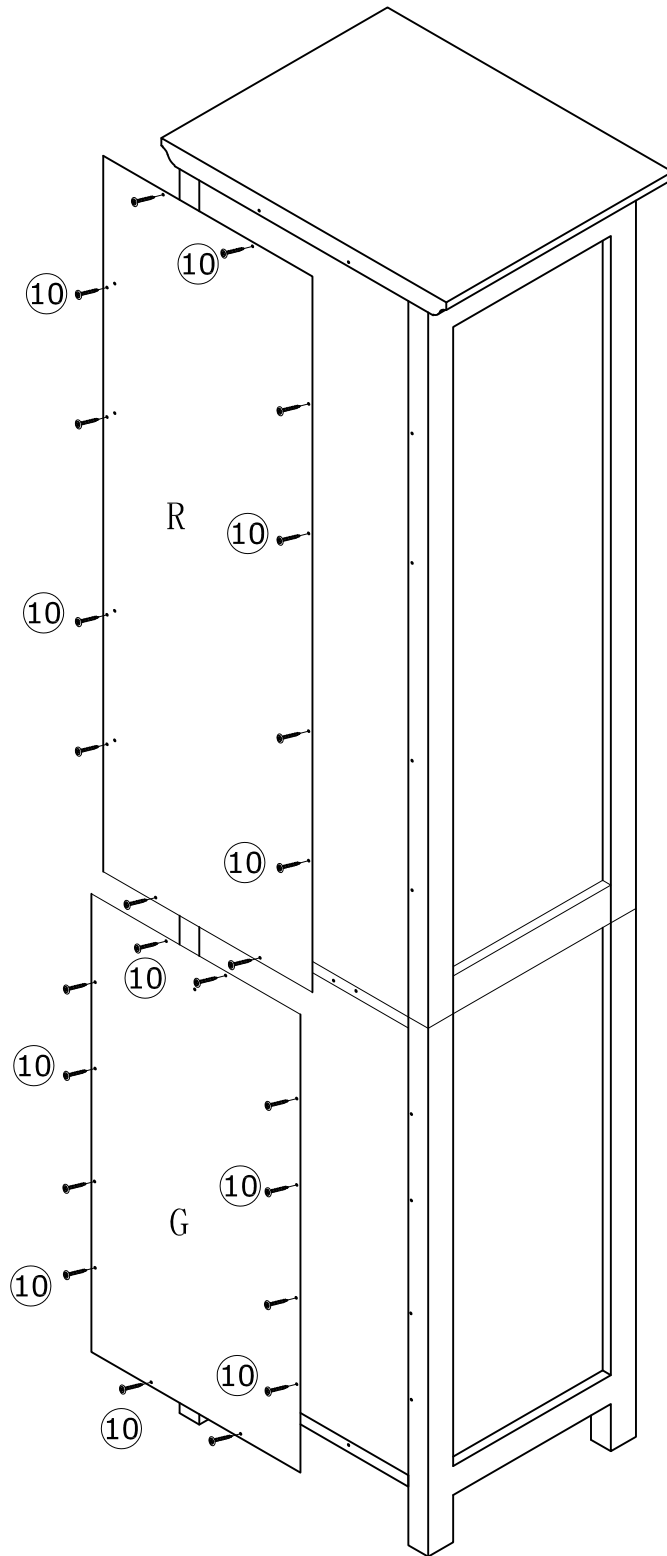

STEP 6:

1. Attach panels R & G to the back of the cabinet with screws (10)

7

5

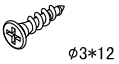

8 PCS

Ø3*12

6



1 PCS

7



2 PCS

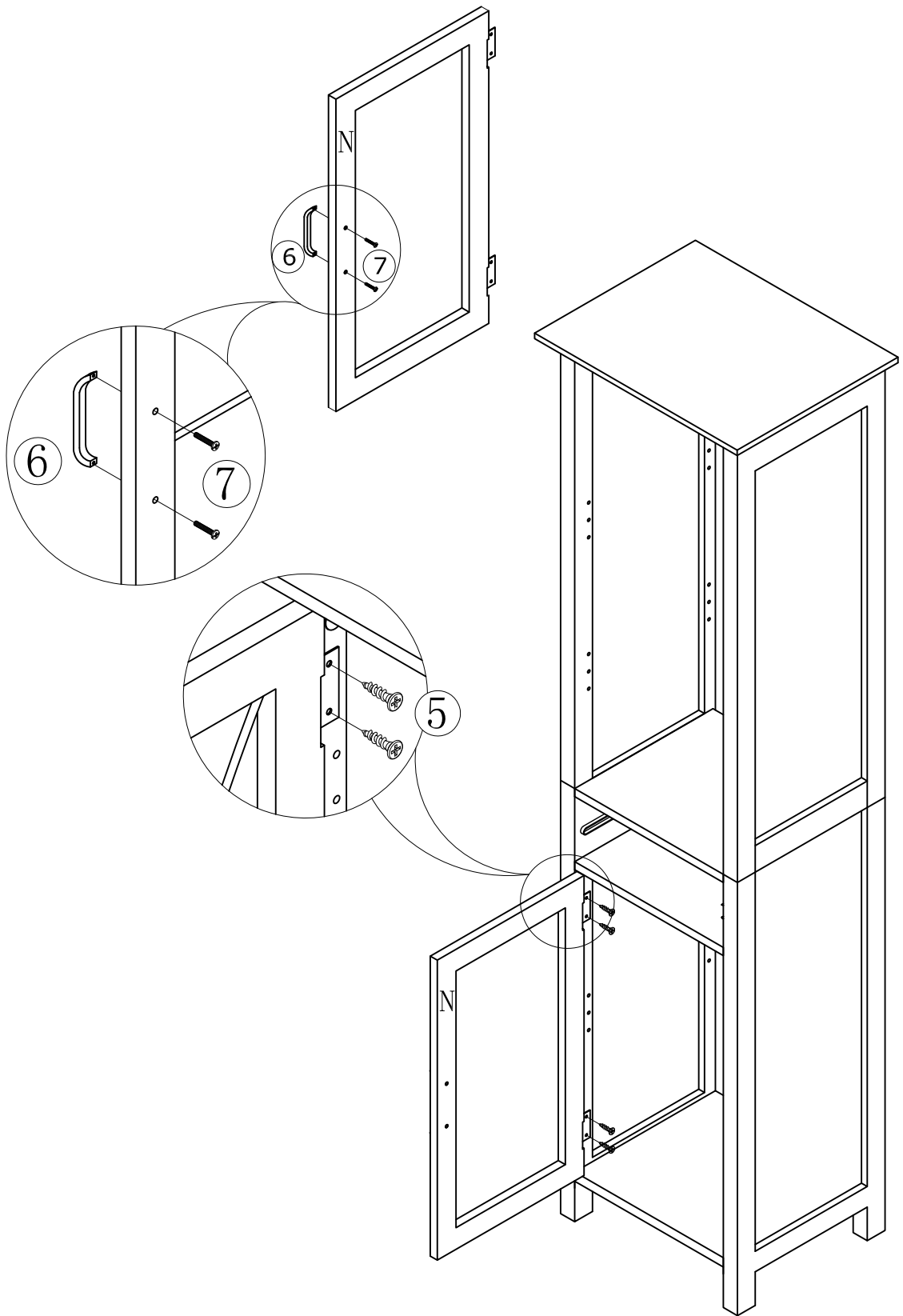

STEP 7:

- 1. Attach handle (6) to door N with bolts (7).**
- 2. Attach door N to the cabinet with screws (5).**

8

4

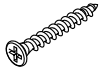

8 PCS $\phi 4 \times 25$

6



1 PCS

7



2 PCS

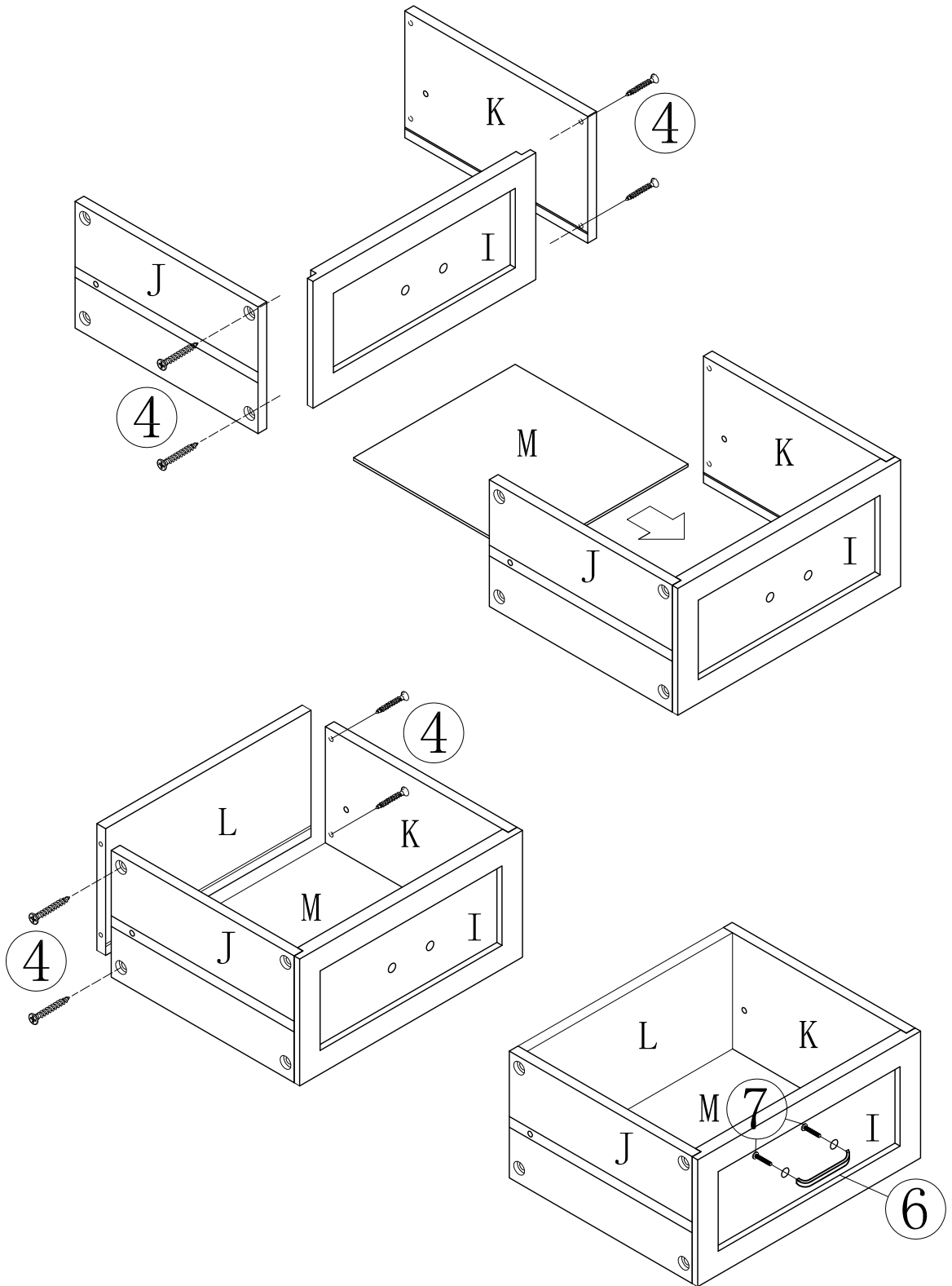

STEP 8:

1. Attach panels J & K to panel I and secure with screws (4).
2. Slide panel M into the panels J, K, & I as indicated.
3. Attach panel L to panels J, K, & M and secure with screws (4).
4. Attach handle (6) to panel I with bolts (7).

9

9



12 PCS

16



2 PCS

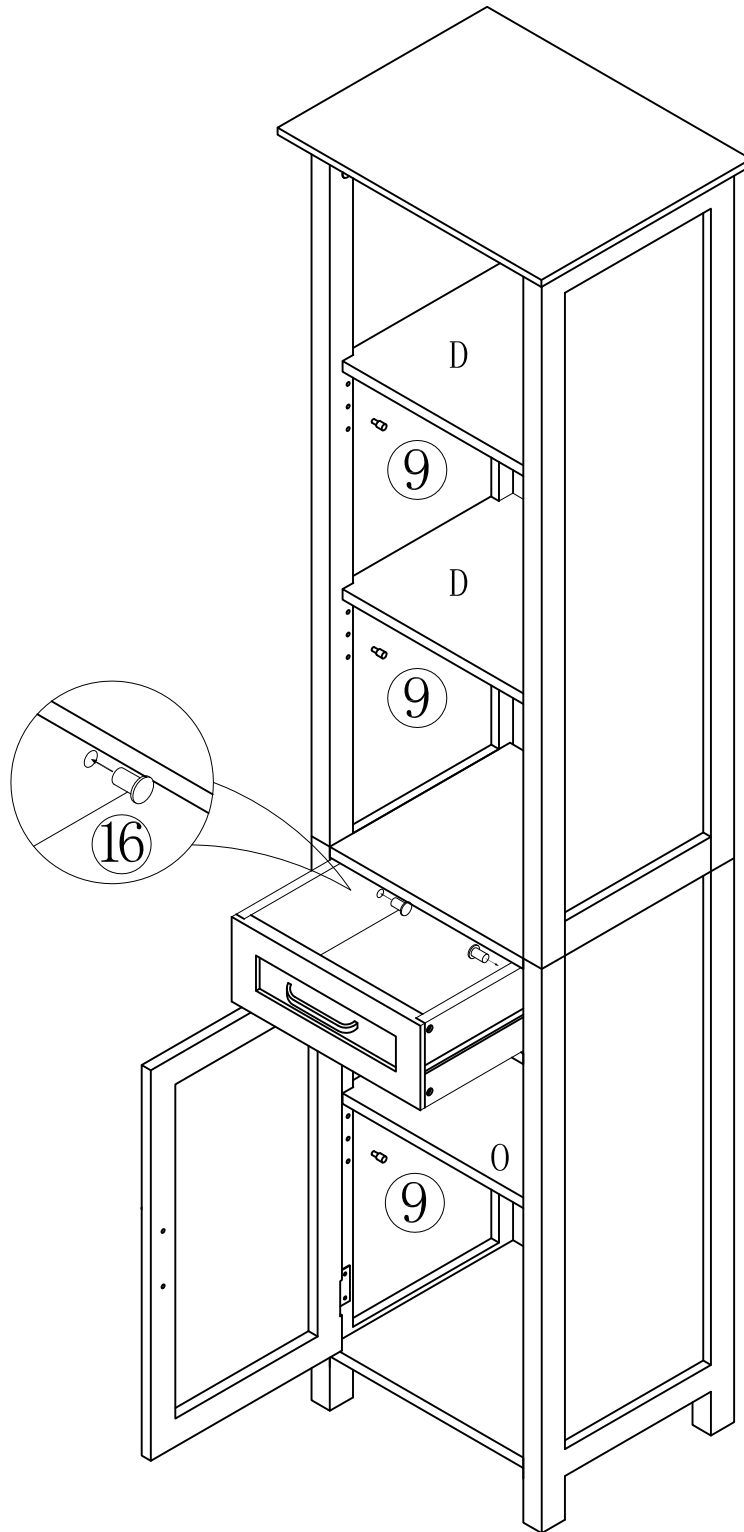

STEP 9:

- 1. Insert drawer into the cabinet and insert the drawer stops (16) as indicated.**
- 2. Insert shelf pins (9) into panels B, C, P, & Q.**
- 3. Rest shelves D & O on the shelf pins.**

10

8



2 PCS

12



1 PC

13



2 PCS

φ4*25

14



1 PC

