

Bar stool

Assembly Guide

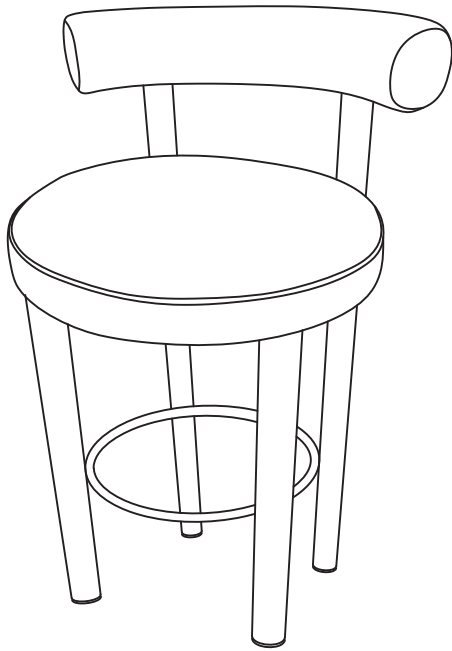

IMPORTANT: please read these instructions fully before starting assembly



**SAFETY AND
CARE ADVICE**



NO POWER TOOLS

- Check you have all the components and tools listed
- Remove all fittings from their bags and separate into groups
- We do not recommend use of power tools - this could damage the unit. Only use hand screwdrivers and Allen keys
- Keep children and animals away from the work area, small parts could cause choking if swallowed
- Make sure you have enough space to lay out the parts before starting
- Assemble the item as close to its final position (same room) as possible
- Do not over tighten the nuts to avoid damage to the threads
- Only clean using a damp cloth and mild detergent. Do not use bleach or abrasive cleaners
- From time to time, check there are no loose screws in this unit
- This product should not be discarded with household waste. Take to your local authority waste disposal centre
- Unless otherwise stated, this product is designed for domestic use and is not certified for commercial or contract settings.

IMPORTANT INFORMATION



20Minute
Build



Two Person
Build



Max Weight
Capacity
120kg







Note: Assembly estimates are approximate and can differ based on the specific environment and user experience.

WHAT'S IN THE BOX

Label	Part Name	Drawing	Quantity
1	Chair Back		1
2	Chair Seat		1
3	Front Leg		1
4	Rear Leg		1
5	Footrest		1

WHAT'S IN THE BOX

Note: the quantities are the correct amount to complete the assembly. In some cases more fixings may be supplied than are required.

Label	Hardware Description	Drawing	Size(mm)	Quantity
A	Screw		M6 x 25	4
B	Screw		M8 x 40	2
C	Screw		M6 x 13	4
D	Screw		M6 x 60	4
E	Washer		M8 x 16	14
F	Allen		M5	1



Note:

- Use a clear, flat surface to avoid bumps or scratches before assembling.
- Insert all fixings loosely at first to allow for alignment; only tighten them once everything is properly positioned, as some adjustment may be required.
- Avoid over-tightening, as this may damage the parts.
- Seek assistance when moving large or heavy parts

STEP 1

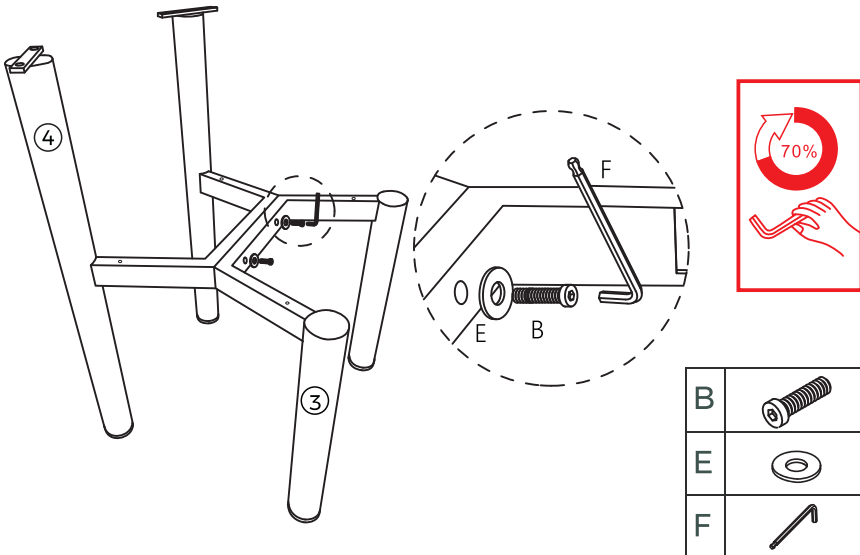
Carefully align the legs [3] and legs [4] together and secure with 2x washers [E] followed by 2x screws [B] and loosely tighten with Allen key [F].





B		2
E		2
F		1

STEP 2

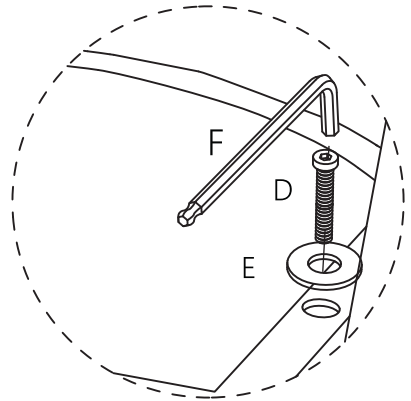
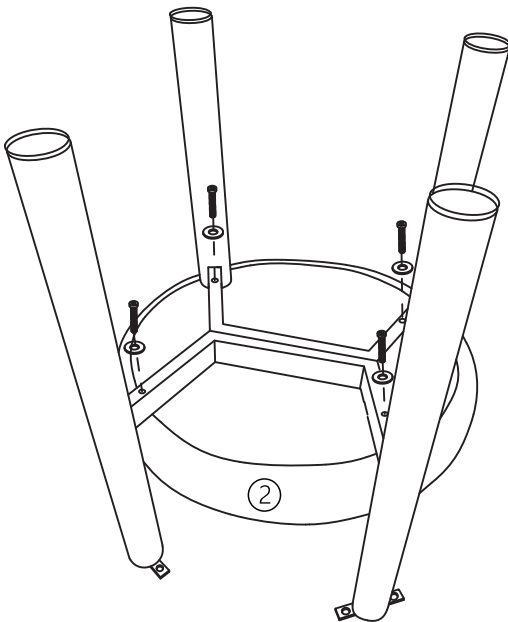
Attach the chair seat [2] to the legs. You may find it easier using the edge of a table to assist. Align the pre-drilled holes and secure the chair seat using 1x washer [E] + 1x Screw [D] per hole (4 of each in total). Loosely tighten with Allen key [F].







D		4
E		4
F		1

STEP 3

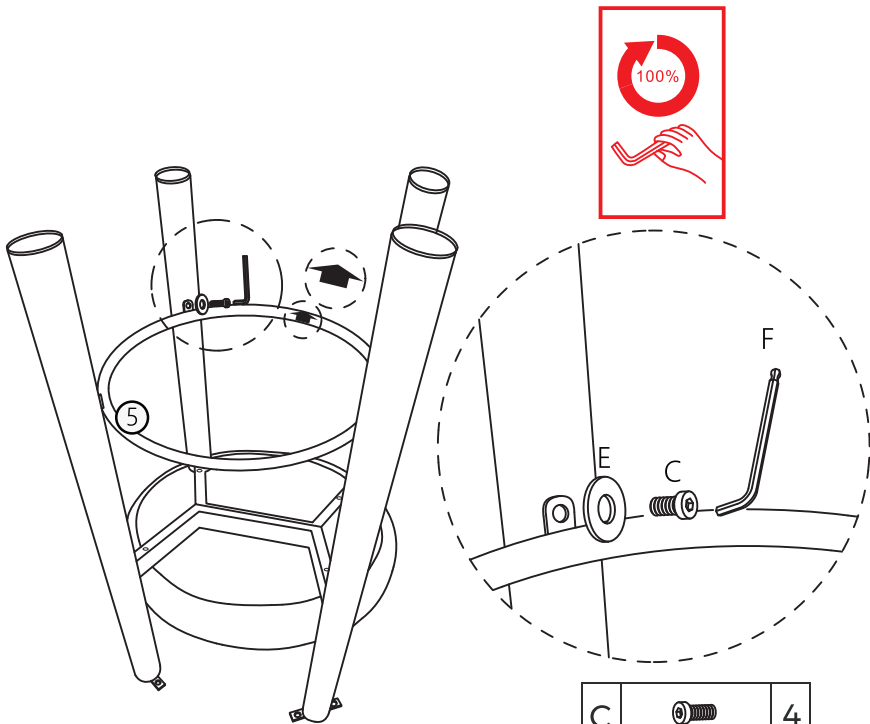
Secure Footrest [5] to Front Leg [3] and Rear Leg [4], using 4 x Screws [C] and 4 x Washers [E] by Allen Key [F].

Fully tighten All Screws [B] in step 1 and All Screws [D] in step 2 Allen key Allen key [C], step 3 with Allen key [F].



C		4
E		4
F		1

STEP 4

Fix Back [1] to the Rear Leg [4] through holes shown using 4x Screws [A] and 4 x Washers [E] by Allen Key [F].

Fully tighten the Screws 100%.

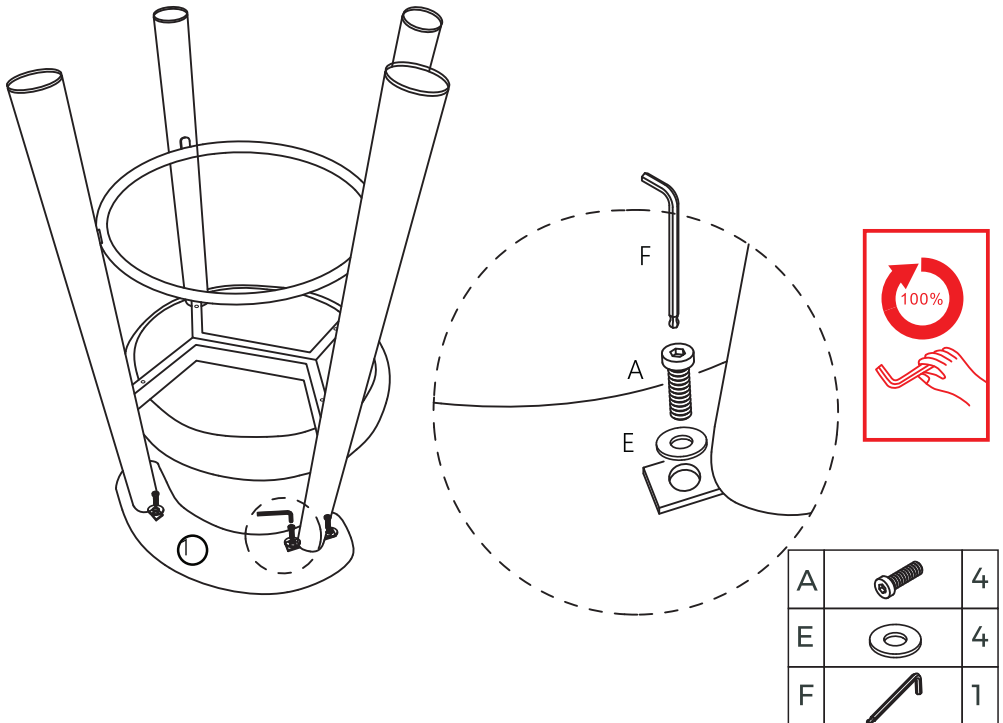

STEP 5

Once secure, place the chair upright on a level surface and adjust screw feet and keep all legs in the same horizontal plane.

Your new chair is now ready to use!

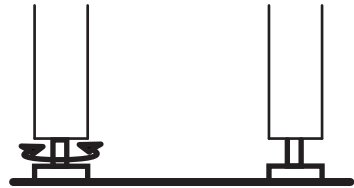
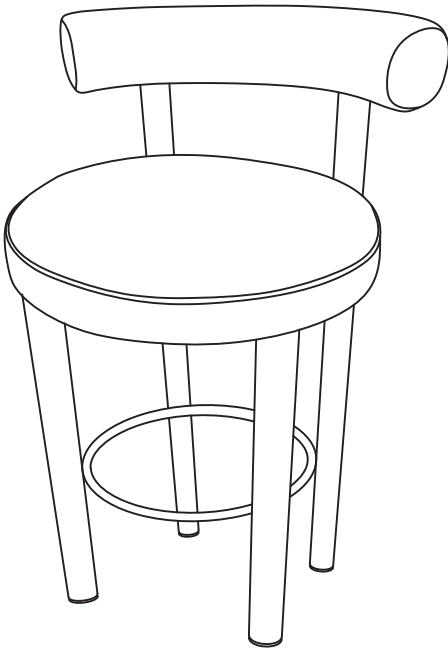

Please ensure any and all fixings and fittings are FULLY tightened before using this product



our 2 year GUARANTEE

Our products come with a 2 year guarantee, giving you extra peace of mind when shopping with us!

What the guarantee covers



PRE-INSERTED FIXINGS
e.g. loose metal threads



FAULTY JOINTS
e.g. legs bending



EXTERNAL FIXING FAULTS
e.g. metal discs removing
from table top



STRUCTURAL INTEGRITY
e.g. the frame of the
product
