

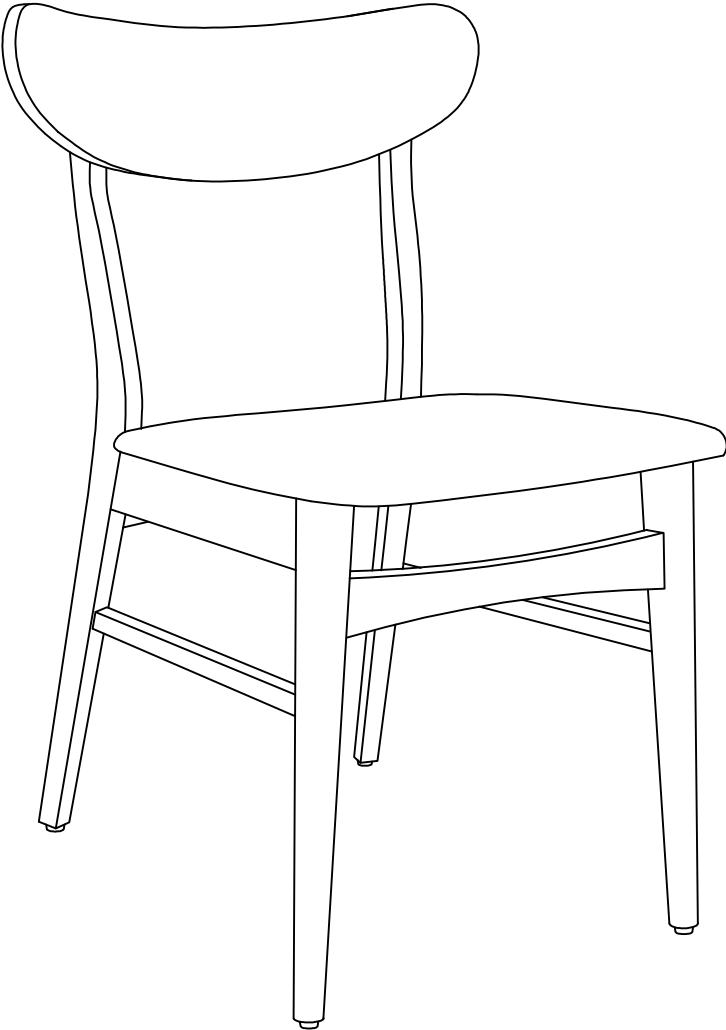

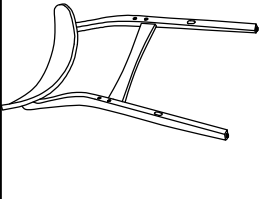

Wood Dining Chair

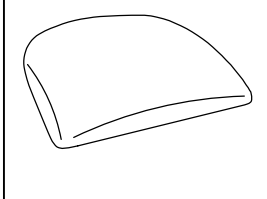
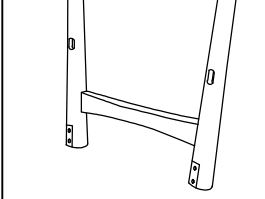
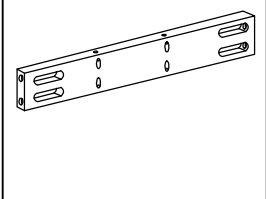
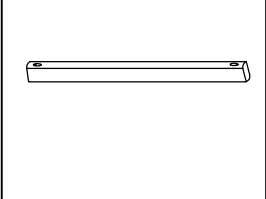

PART LIST

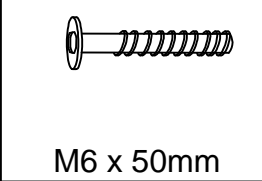
<div style="border: 1px solid black; padding: 2px; text-align: center;">A</div> 	<div style="border: 1px solid black; padding: 2px; text-align: center;">B</div> 	<div style="border: 1px solid black; padding: 2px; text-align: center;">C</div> 	<div style="border: 1px solid black; padding: 2px; text-align: center;">D</div> 	<div style="border: 1px solid black; padding: 2px; text-align: center;">E</div> 
<p style="text-align: center;">Back 2 PCS</p>	<p style="text-align: center;">Seat 2 PCS</p>	<p style="text-align: center;">Front Leg 2 PCS</p>	<p style="text-align: center;">Side Rail 4 PCS</p>	<p style="text-align: center;">Strecher 4 PCS</p>

HARDWARE LIST

<div style="border: 1px solid black; padding: 2px; text-align: center;">#1</div>  <p style="text-align: center;">M6 x 50mm</p>	<div style="border: 1px solid black; padding: 2px; text-align: center;">#2</div>  <p style="text-align: center;">1/4"</p>	<div style="border: 1px solid black; padding: 2px; text-align: center;">#3</div>  <p style="text-align: center;">M4 x 32mm</p>	<div style="border: 1px solid black; padding: 2px; text-align: center;">#4</div>  <p style="text-align: center;">M4</p>
<p style="text-align: center;">Bolt 16 PCS (Extra 2)</p>	<p style="text-align: center;">Spring Washer 16 PCS (Extra 2)</p>	<p style="text-align: center;">Screw 16 PCS (Extra 2)</p>	<p style="text-align: center;">Allen Wrench 1 PC</p>

ADDITIONAL TOOLS (Not Provided)

Note: It is not recommended to use power tools during assembly.

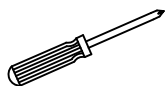

Phillips Head Screwdriver

Step 1 . Attach side rails (part D) to back (part A) using bolts (part #1), spring washers (part #2) and allen wrench (part #4). See Figure 1. Attach stretchers (part E) to back (part A) using screws (part #3) and phillips head screwdriver. See Figure 2.

NOTE: Please do not fully tighten bolts until unit is fully assembled.

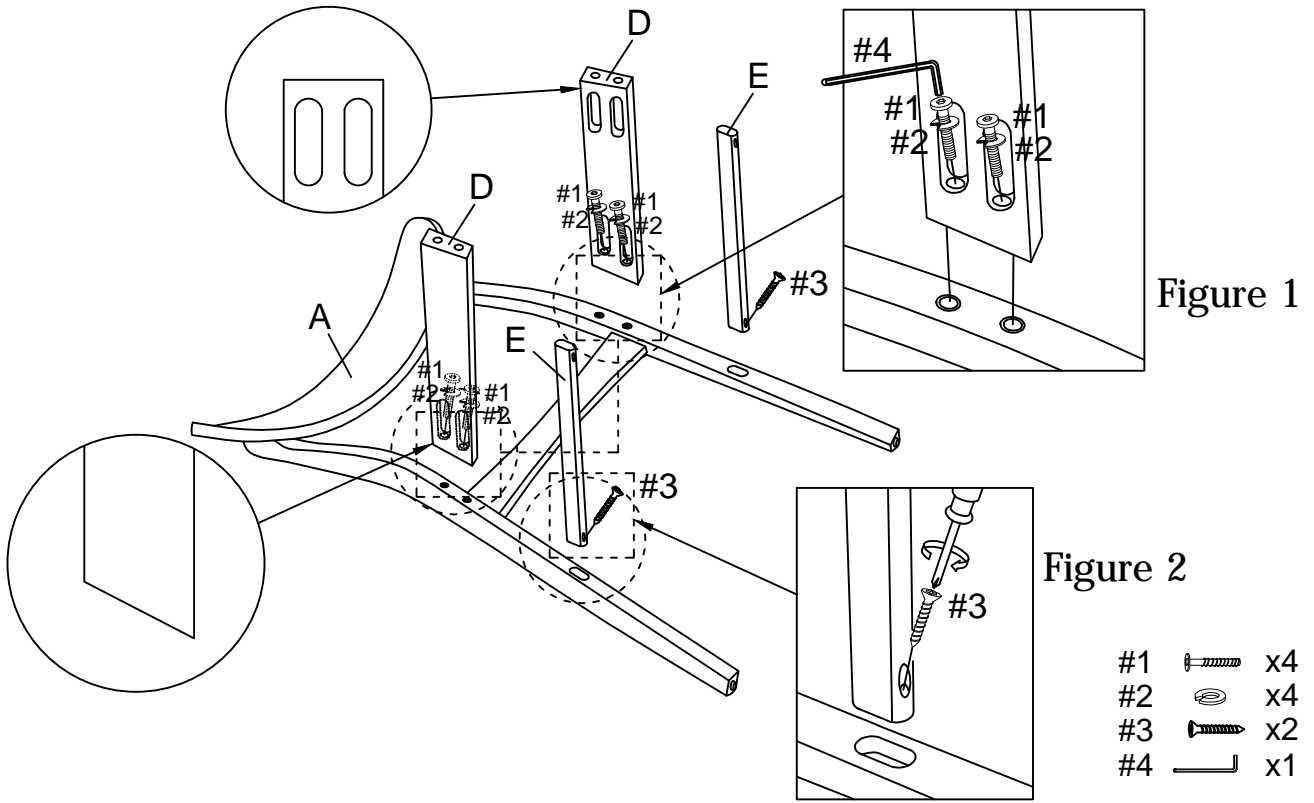

Step 2 . Attach front leg (part C) to side rails (part D) and stretchers (part E) using bolts (part #1), spring washers (part #2), screws (part #3), allen wrench (part #4) and phillips head screwdriver.

NOTE: Please fully tighten all bolts at this time.

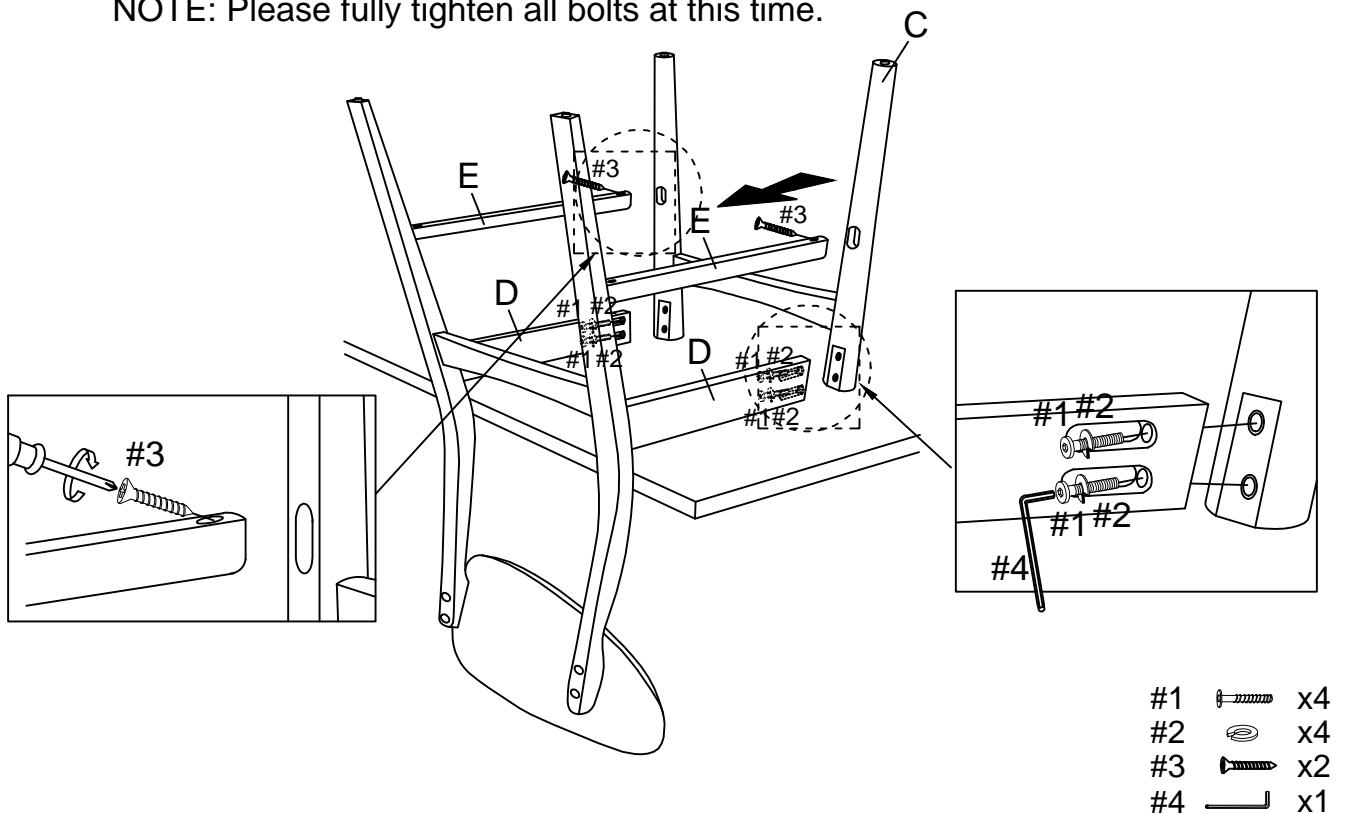

Step 3 . Attach seat (part B) to assembled unit (parts A, C, D & E) using screws (part #3) and phillips head screwdriver.

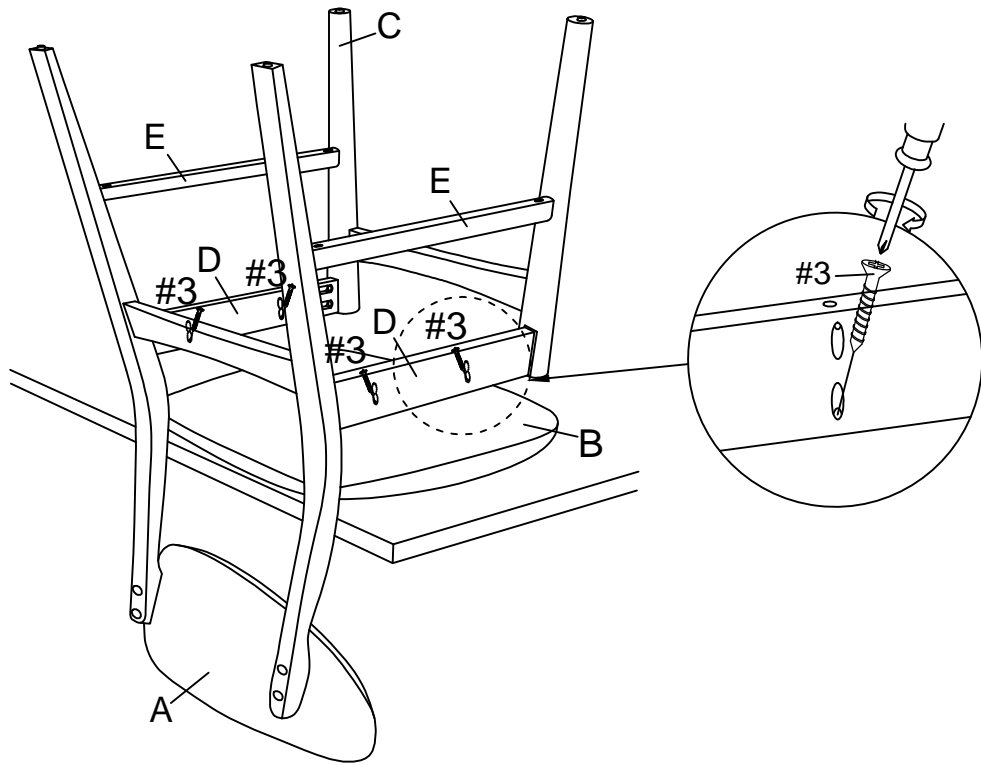

#3  x4

Step 4. Carefully turn unit upright. Repeat steps 1-3 to assemble remaining chair.

