

ASSEMBLY INSTRUCTION

TWIN/FULL UPPER & LOWER HEADBOARD/FOOTBOARD
 TWIN/FULL RAIL/GUARD RAIL/LADDER
 TWIN/FULL UPPER & LOWER SLAT

CAUTION:

⚠ It is recommended to install protective pad under all legs and support to avoid damage or scratched when placing furniture on a wood floor or other hard surface . And to limit indentation and prevent discoloration if placing on carpet.

NOTE: DO NOT TIGHTEN BOLT UNTILL COMPLETELY ASSEMBLED.

PART LIST:

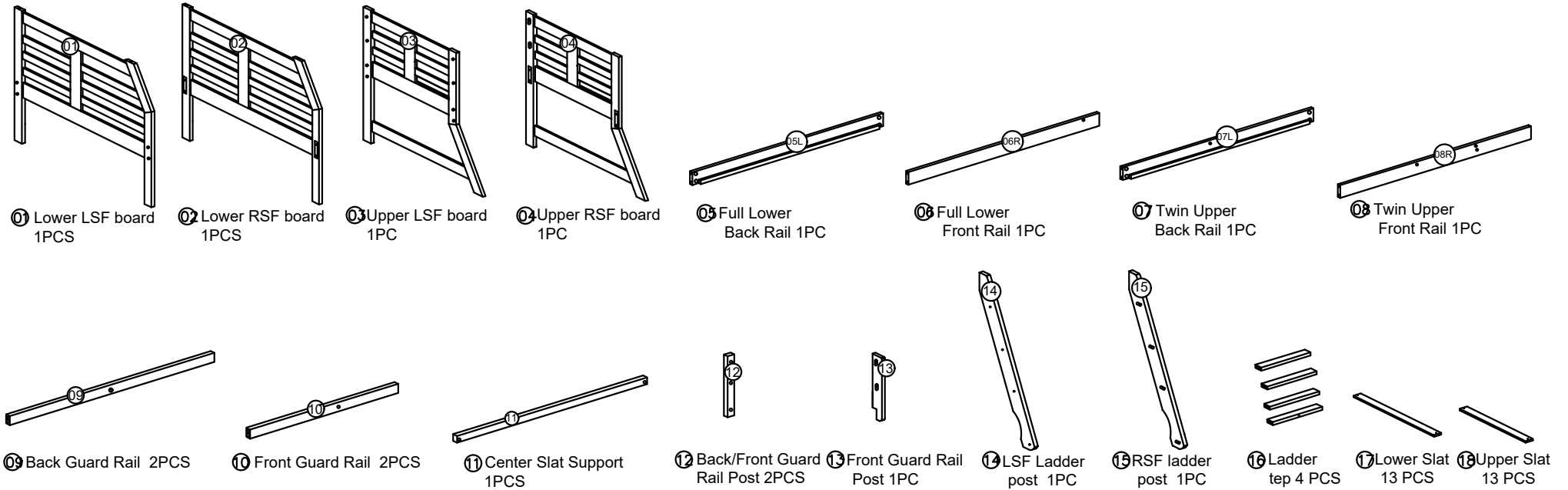

HARDWARE LIST(Hardware package packed with headboard/footboard)

A		Bolt	1/4"X3 3/16"	16PCS	H		Metal Pin	3 1/2"	4PCS
B		Bolt	1/4"X3 1/8"	6PCS	I		Bracket		2PCS
C		Bolt	1/4"X2 3/8"	10PCS	J		Washer		16PCS
D		Bolt	1/4"X1 3/8"	9PCS	L		Bracket		2PCS
E		Screw	1/8"X5/8"	14PCS	N		Bolt	1/4"X2"	2PCS
F		Wrench		1PC	M		Nut		2PCS
G		Screw	5/32"X1 3/8"	52PCS					

STEP 1

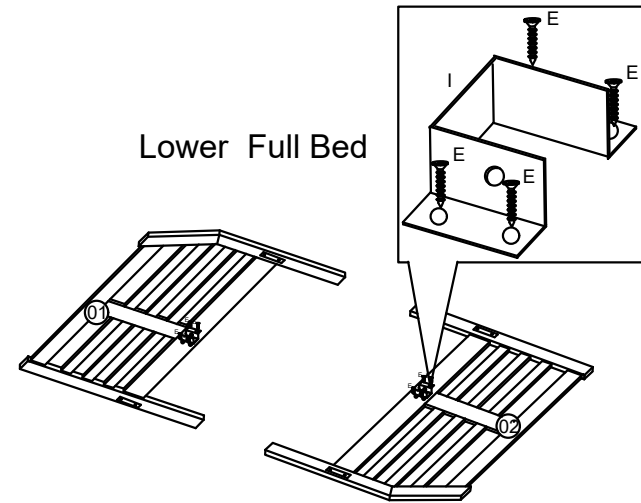
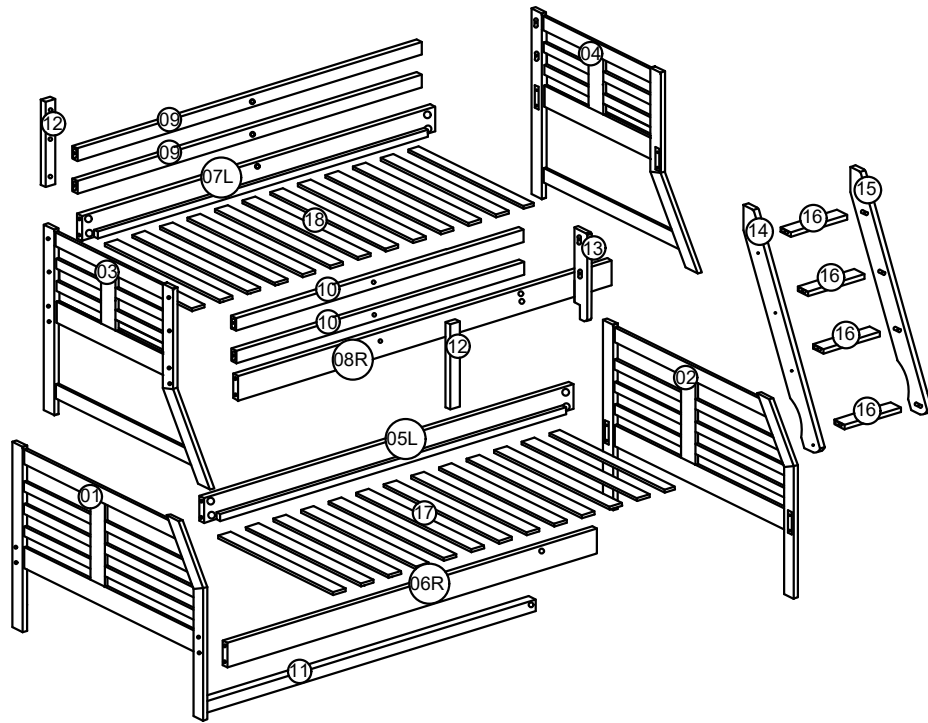

I = 2pcs
E = 8pcs

STEP 2

Lower Full Bed

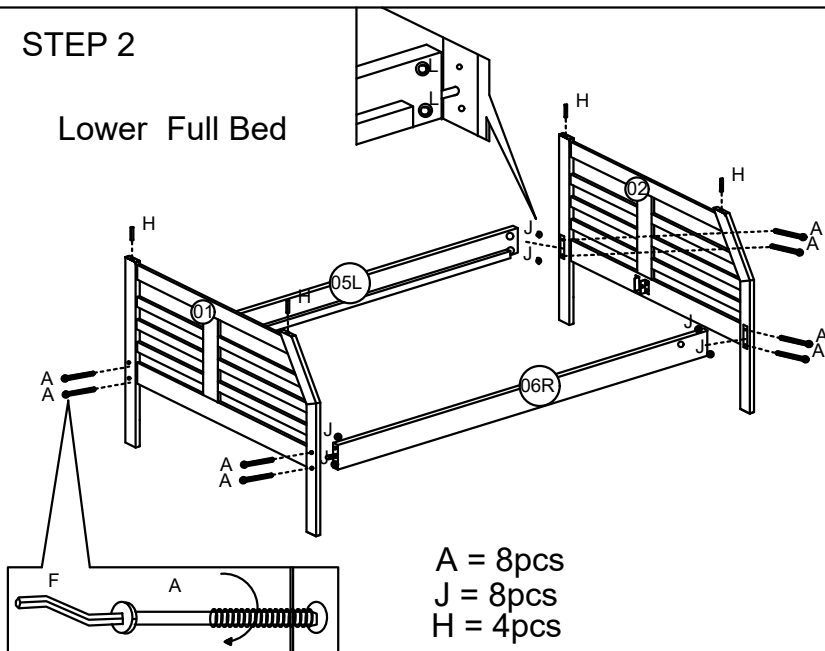

STEP 3

Lower Full Bed

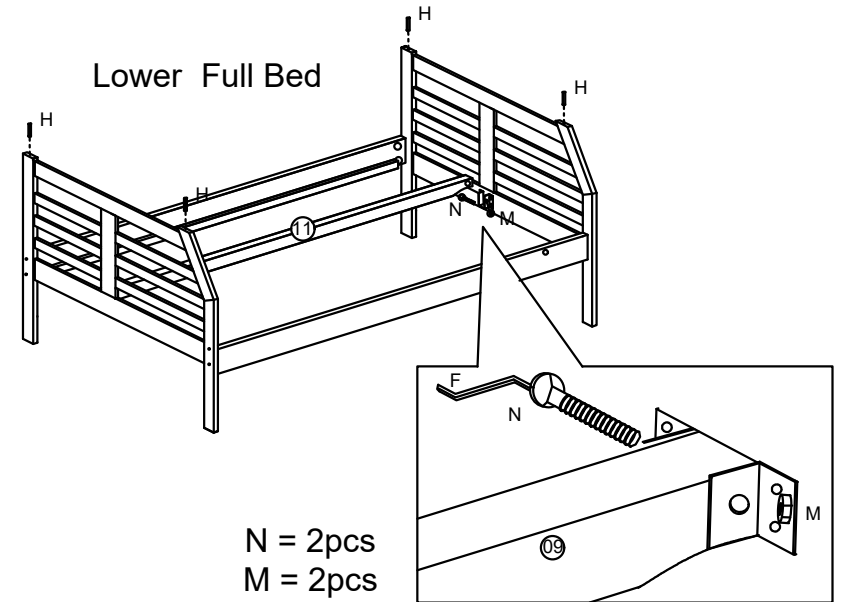

HOMELEGANCE

STEP 4

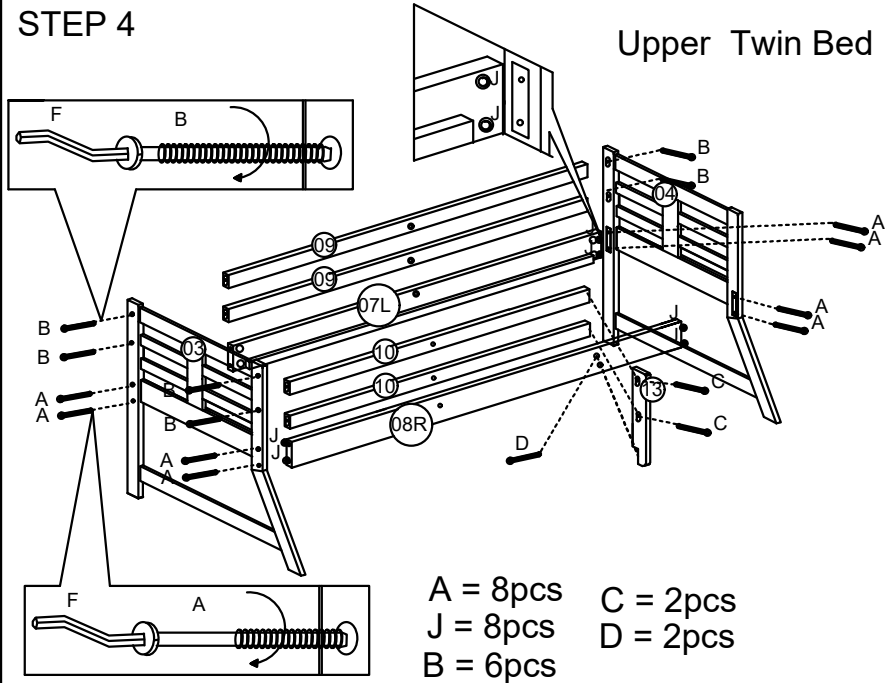

STEP 5

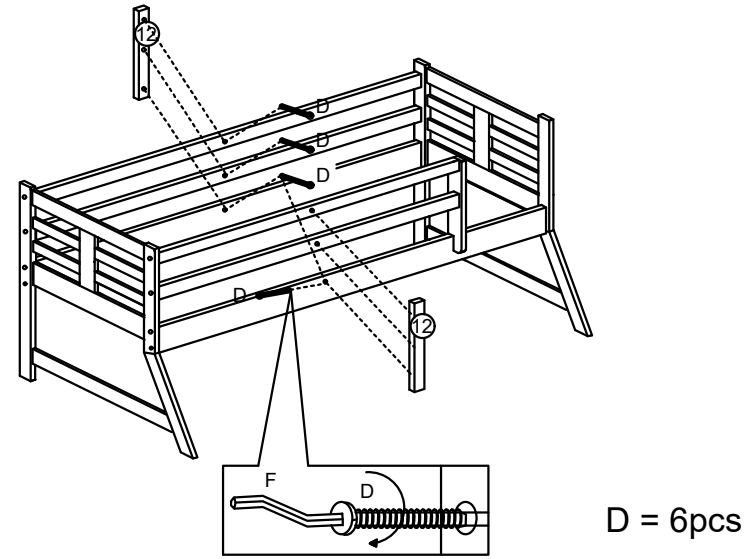

STEP 6

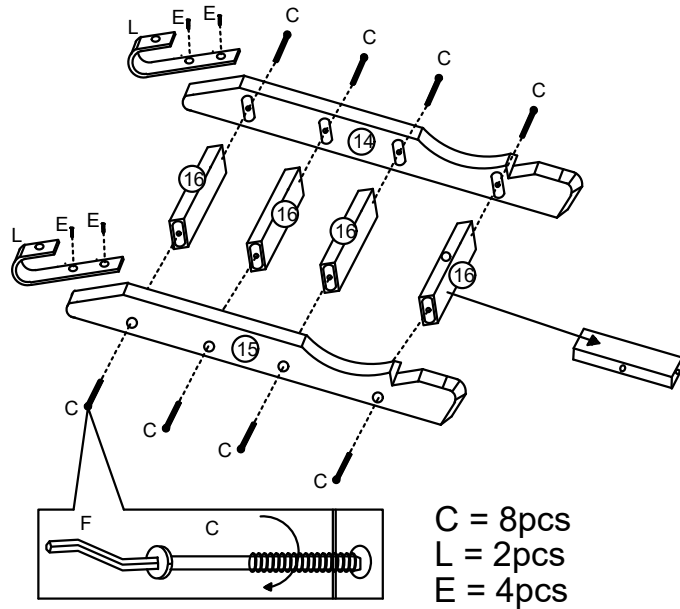

STEP 7

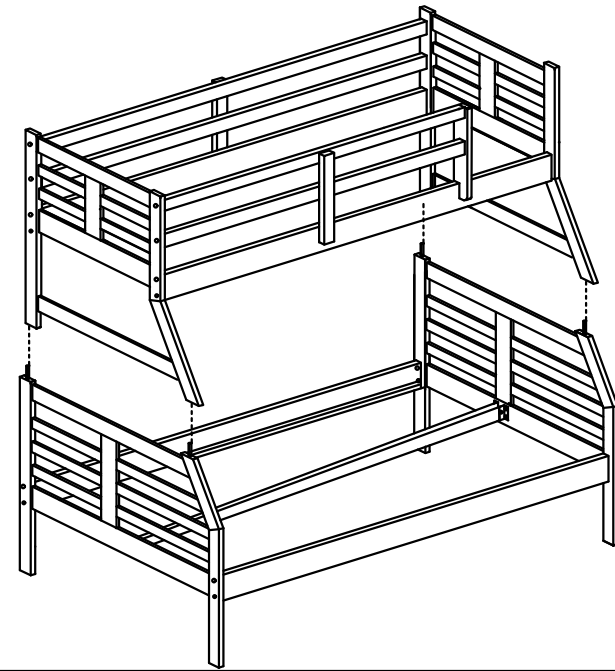

STEP 8

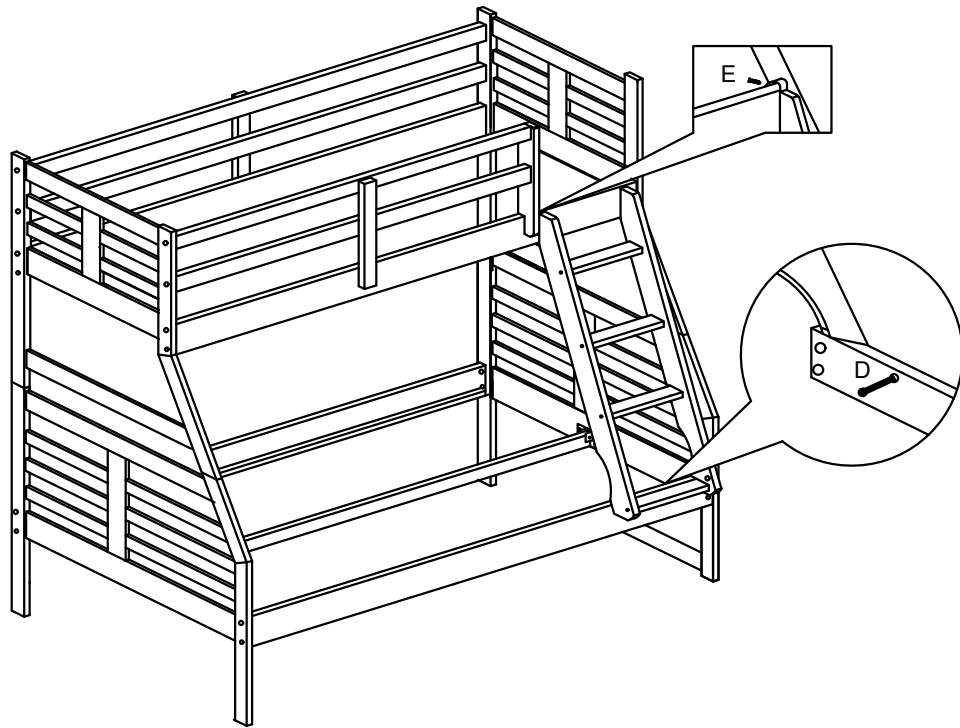

E = 2pcs
D = 1pc

STEP 9

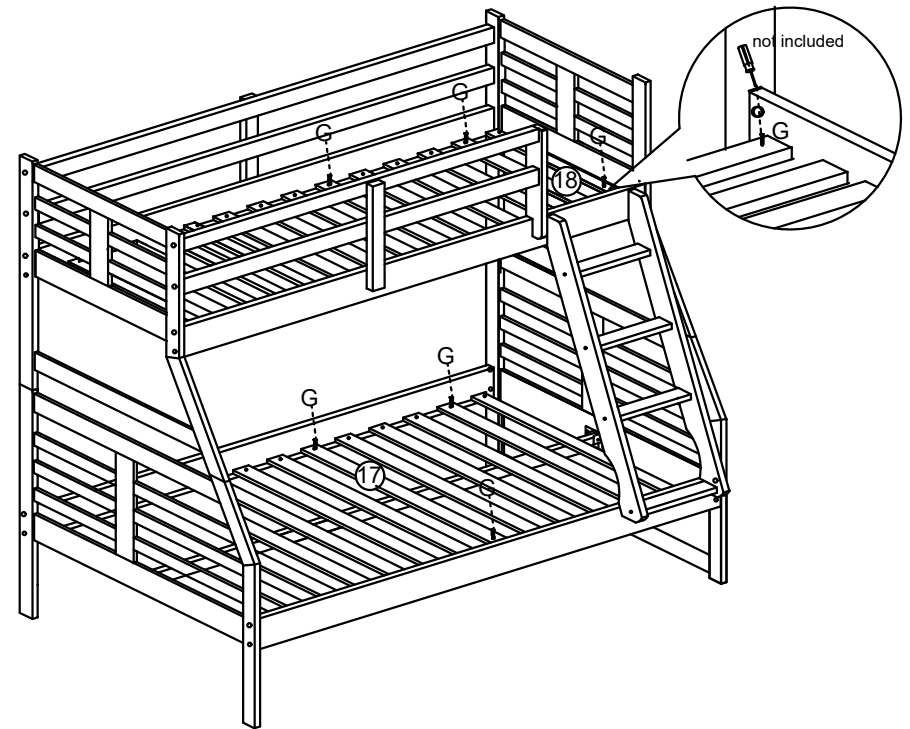

G = 52pcs

COMPLETED!

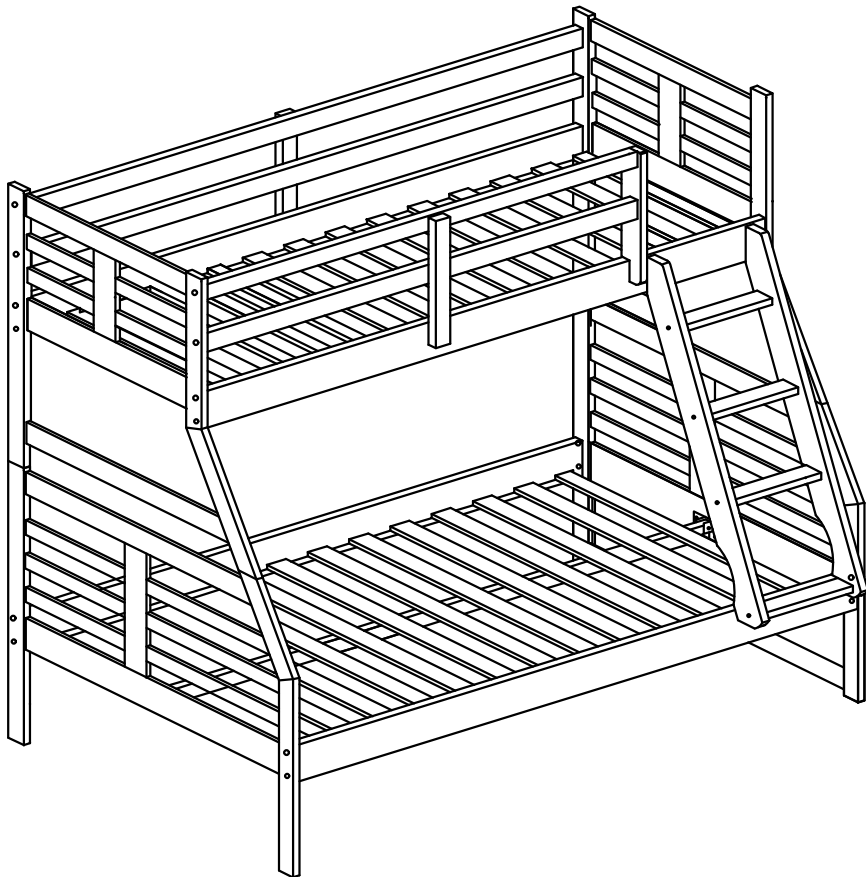

SAFETY WARNING

Homelegance puts your child's safety as a Top Priority. Our bunk beds have been tested by an independent laboratory and certified to be in compliance with ASTM F-1427, "Standard Consumer Safety Specification for Bunk Beds" and U.S. Government specifications 16 Code of Federal Regulations, Parts 1213 and 1513.

1. Follow the information on the warning attached to the upper end structure and on the carton. Do not remove this label.
2. Always use the recommended size mattress or mattress support or both to help prevent the likelihood of entrapment or falls.
3. Ensure thickness of mattress does not exceed 6" and mattress surface at least 5" inches below upper edge of guardrails.
4. Do not allow children less than six years of age to use the upper bunk.
5. Prohibit more than one person on upper bunk.
6. Periodically check and ensure that the guardrail, ladder and other components are in their proper position, free from damage, and that all connectors are tight.
7. Do not allow horseplay on or under the bed and prohibit jumping on the bed.
8. Always use the ladder for entering and leaving the upper bunk.
9. Do not use substitute parts. Contact the manufacturer or dealer for replacement parts.
10. Use of a night light may provide added safety precaution for a child using upper bunk.
11. If the bunk bed will be placed next to a wall, the guardrail that runs the full length of the bed should be placed against the wall to prevent entrapment between the bed and the wall. (This applies only to bunk beds without two full-length guardrails.)
12. Always use guardrails or both long sides of the upper bunk.
13. The use of water or sleep flotation mattress is prohibited.
14. Keep these instructions for future reference.

STRANGULATION HAZARD:

15. Never attach or hang items to any part of the bunk bed that are not designed for use with the bed for example, but not limited to hooks, belts, and jump ropes.

SIZE OF MATTRESS AND FOUNDATION:

16 Mattress dimension for upper bunk: 37 $\frac{1}{2}$ " - 38 $\frac{1}{2}$ " in width, 74" - 75" in length and thickness of mattress does not exceed 6".

17 Mattress dimension for lower bunk: 53 $\frac{1}{2}$ " in width, 75" in length and 9" in thickness. Note: There must be at least 5" from mattress sleeping surface to top edge of guardrail.

REPLACEMENT PARTS

Replacement parts, including additional guardrails may be obtained from any Dealer.