

Installation & Assembly

ver A

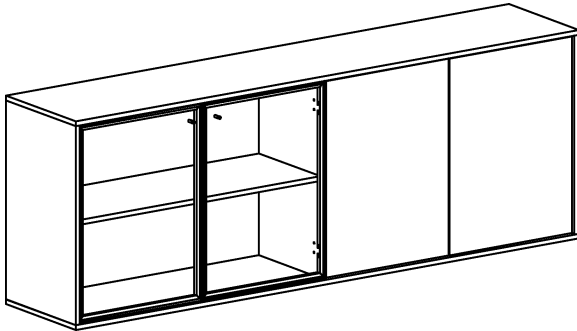

ver B

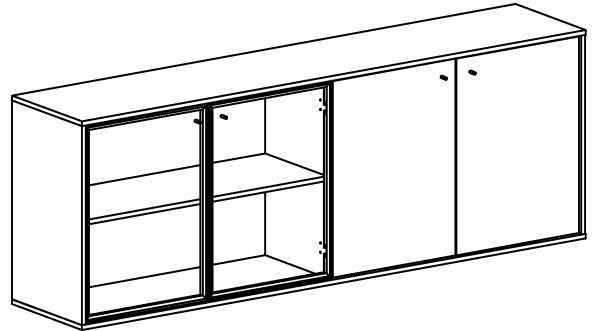

- Ⓓ **Montageanleitung**
- Ⓐ **Handleiding voor de montage**
- Ⓓ **Montaj talimatı**
- Ⓕ **Notice de montage**
- Ⓒ **Montážní návod**
- Ⓗ **Szerelési útmutató**

- Ⓒ **Assembly instructions**
- Ⓐ **Instrukcja montażu**
- Ⓒ **Инструкция по монтажу**
- Ⓖ **Istruzioni di montaggio**
- Ⓐ **Návod na montáž**
- Ⓐ **Instrucțiuni de montaj**

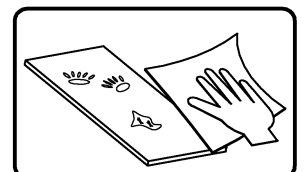
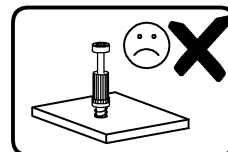
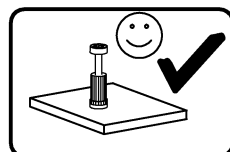
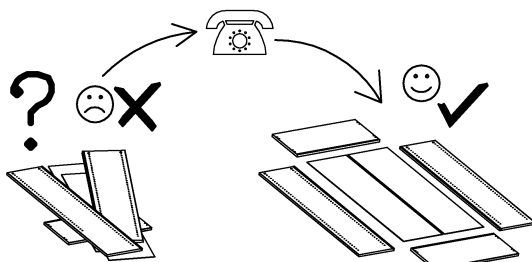
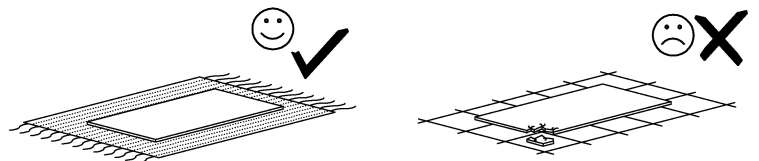
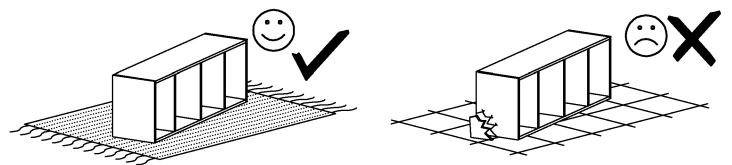
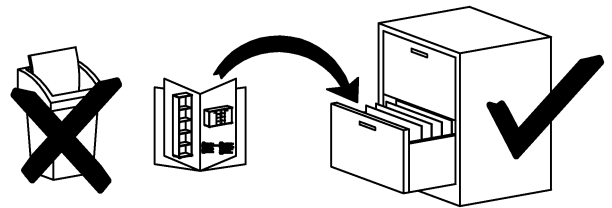
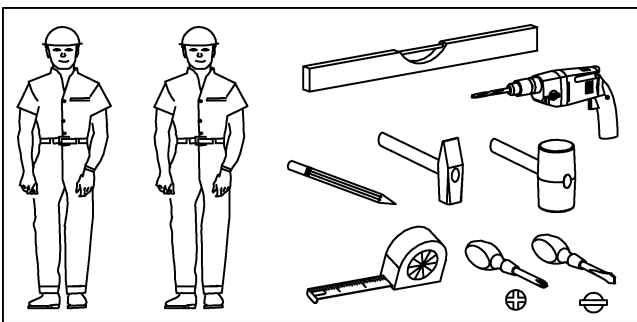

Name • Nom • Nome • Naam • Nazwa • Jméno
• Názov • Név • Denumire • Isim • Имя

Nr • No • N° • Номер • Č • Sz

Typ • Type • Tip • Тіpus • Тип • Tun

4D

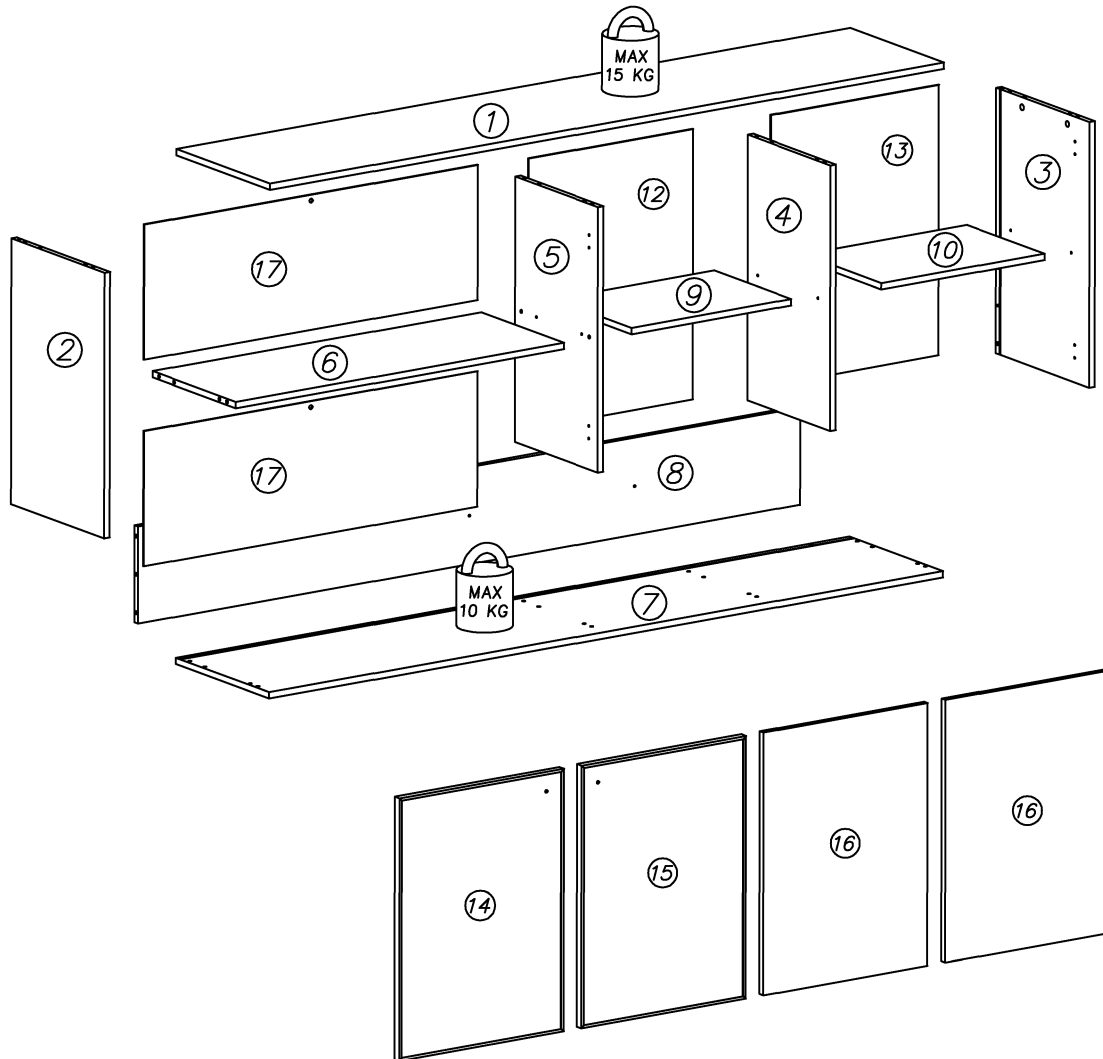
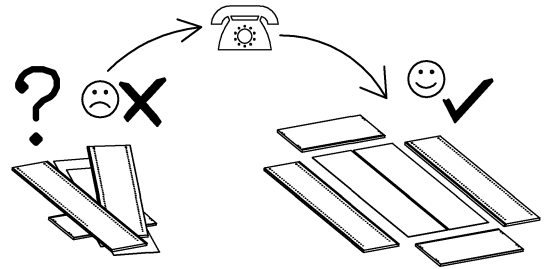
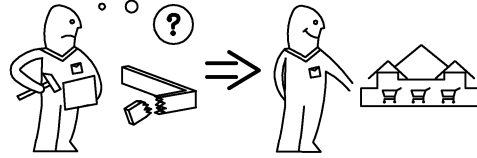
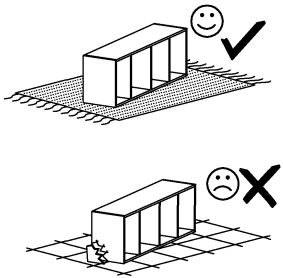

nr	L[mm]	B[mm]	T[mm]	Menge	Colli
1	1997	396	16	1	2/3
2	668	395	16	1	1/3
3	668	395	16	1	1/3
4	668	350	16	1	1/3
5	668	350	16	1	1/3
6	974	350	16	1	2/3
7	1997	396	16	1	2/3

nr	L[mm]	B[mm]	T[mm]	Menge	Colli
8	1963	244	16	1	2/3
9	473	328	16	1	2/3
10	484	328	16	1	2/3
12	680	487	3	1	1/3
13	680	497	3	1	1/3
14	487	660	20	1	1/3
15	487	660	20	1	1/3
16	487	660	16	2	1/3
17	340	989	3	2	2/3

Name • Nom • Nome • Naam • Nazwa • Jméno
• Názov • Név • Denumire • Isim • Имя

Nr • No • N° • Номер • Č • Sz

Typ • Type • Tip • Тípus • Тип • Tun

4D

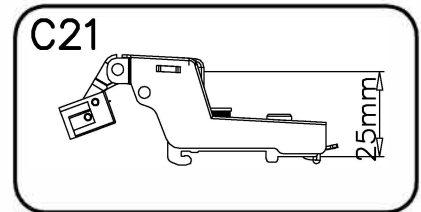
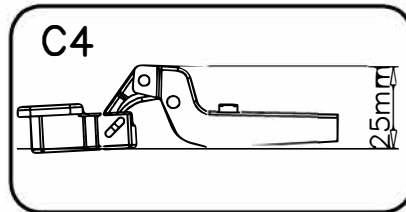
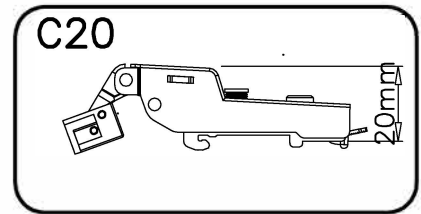
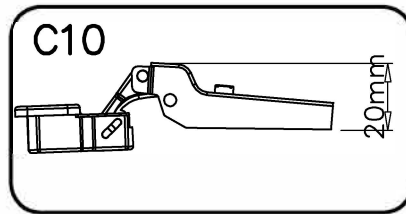
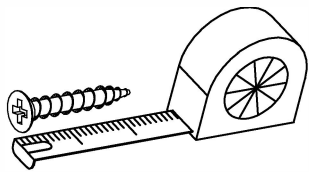
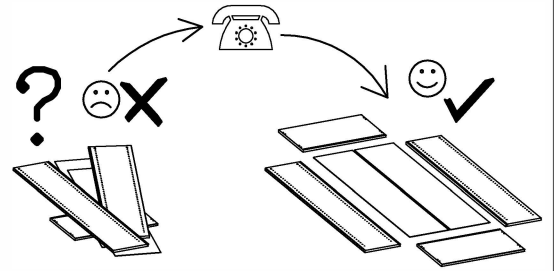
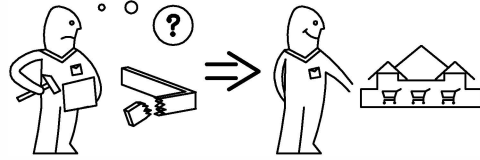
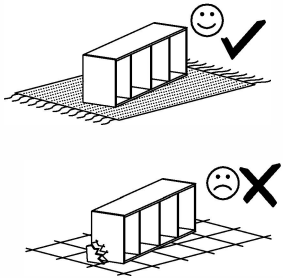

L11		x2	G57		x4
			3,5x16		

I1		x8	S2		x16
			G56		x2
			4x16		
			I3		x2

D20		x2	D21		x2
			D10		x2
			PZ35PL		
			D4		x2
			PZ350D		
			G8		x2
			4x30		

C20		x2	C21		x2
ZALPL			Z35PL		x2
			C4		x2
			Z350D		x2
			E68		x4

G2		x16	F2		x8
3x20			W2		x1
			A1		x14
			ø7x50		
			G14		x2
			3,5x45		

K10		x14	I7		x14
			K1		x14
			ø15x12		
			B1		x24
			ø8x35		
			G4		x8
			4x16		

I

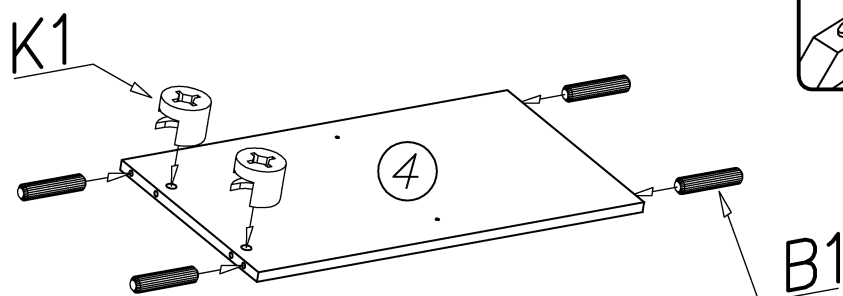
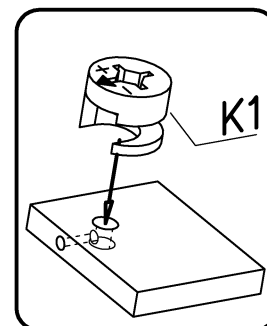
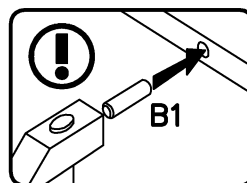
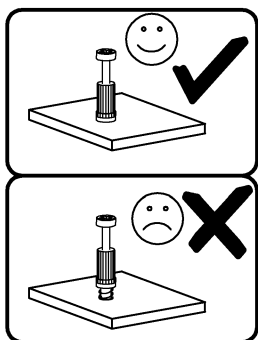
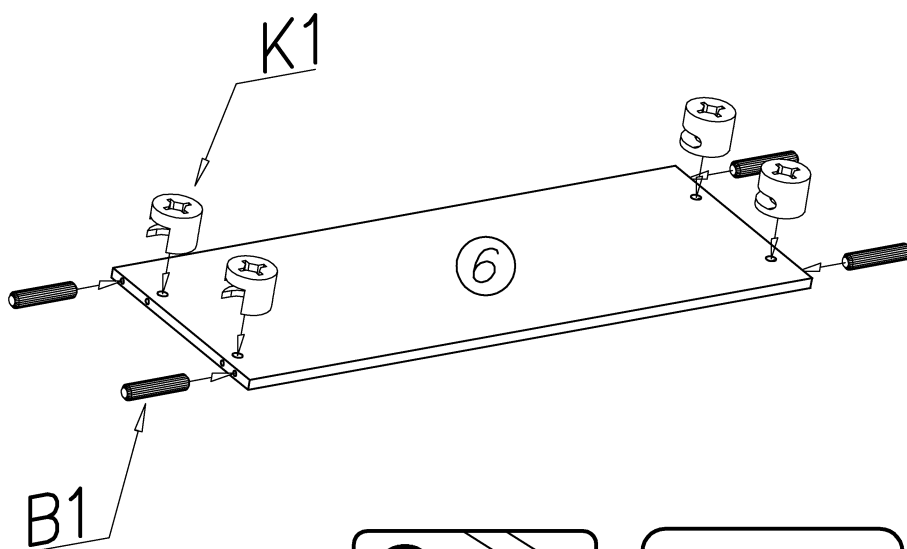
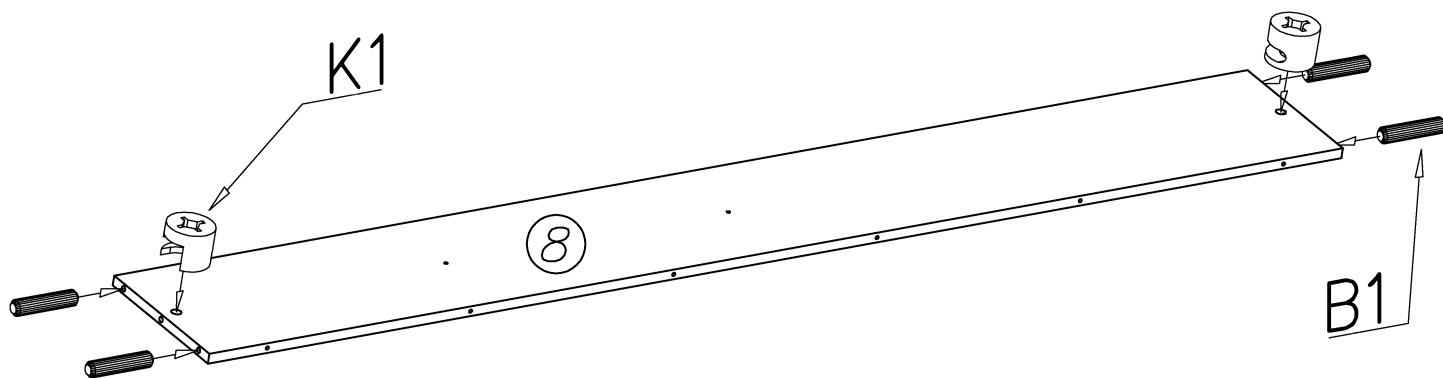
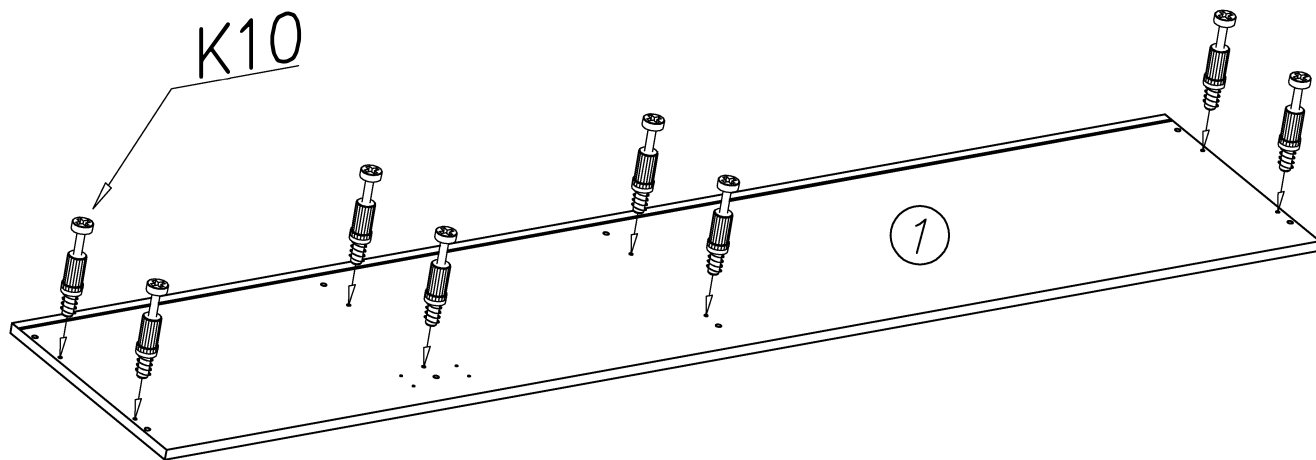

II

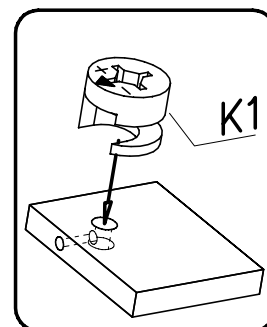
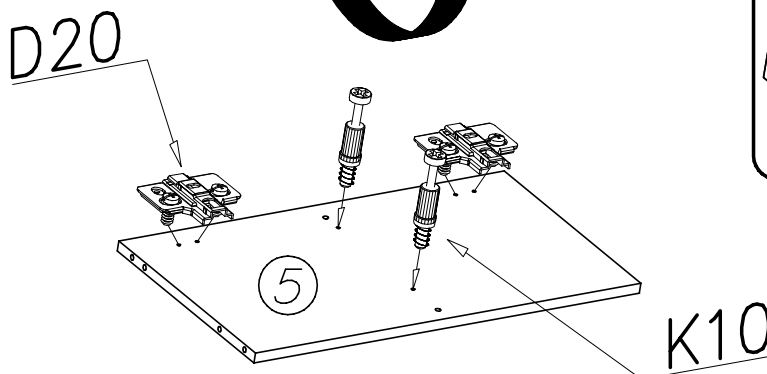
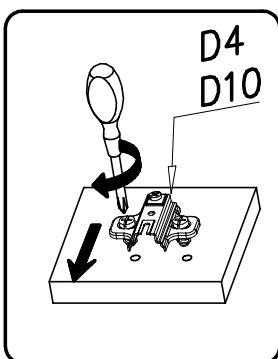
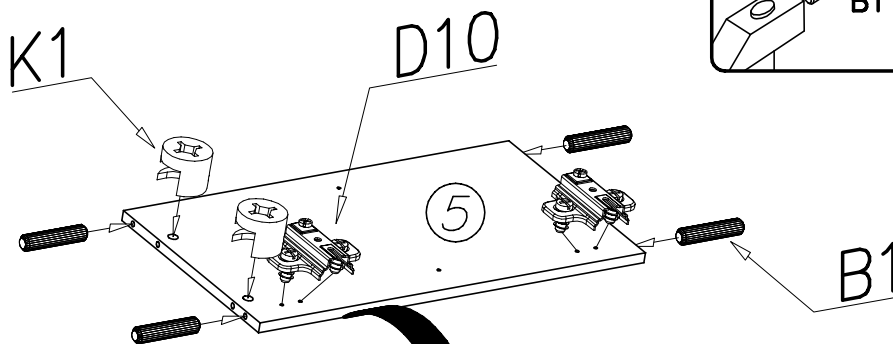
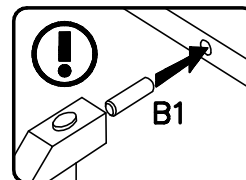
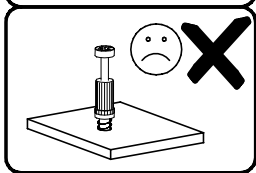
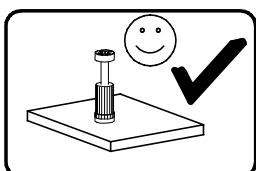
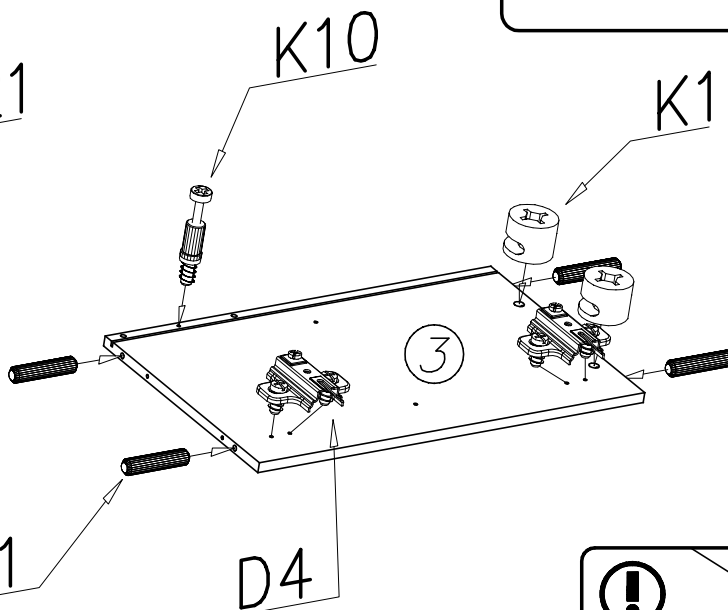
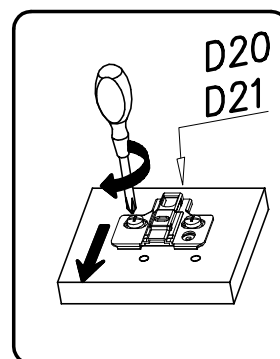
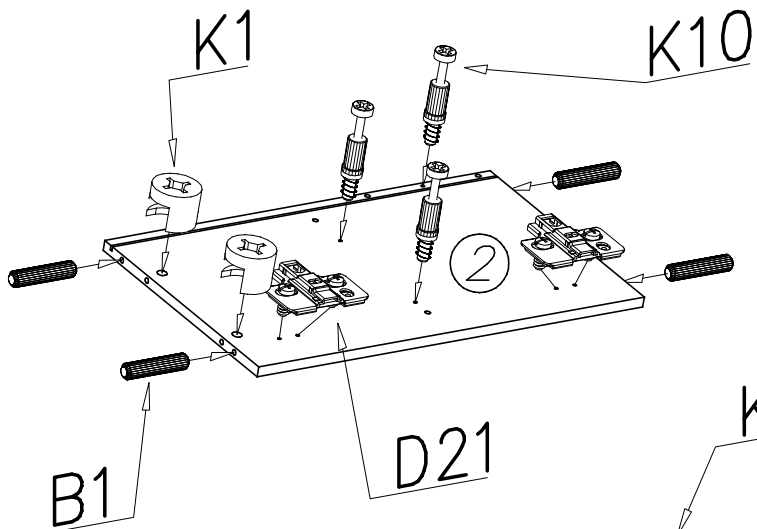

III

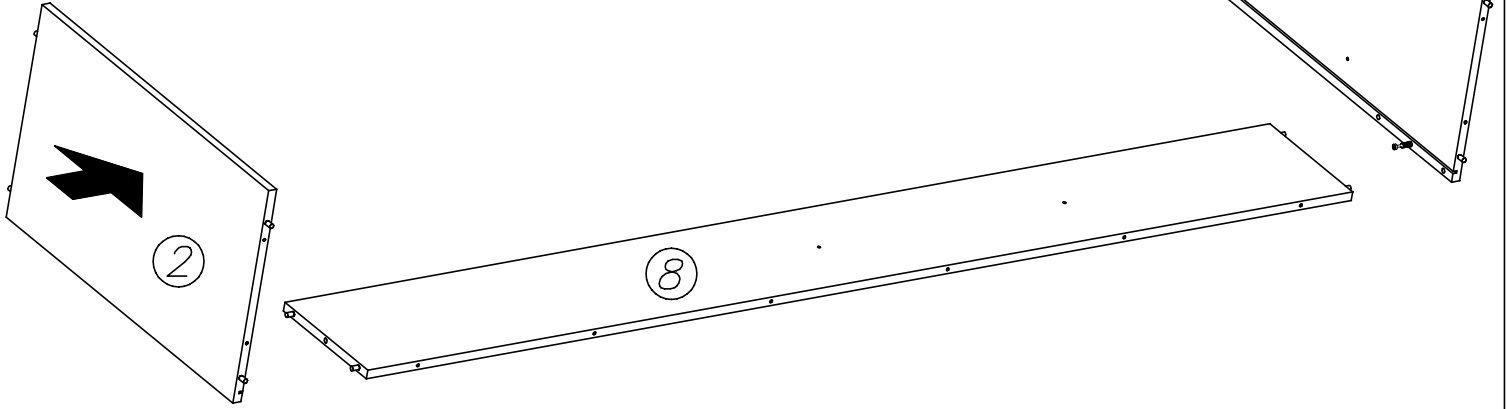
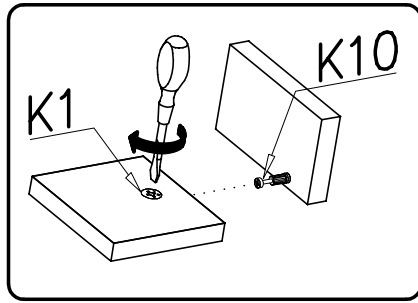

IV

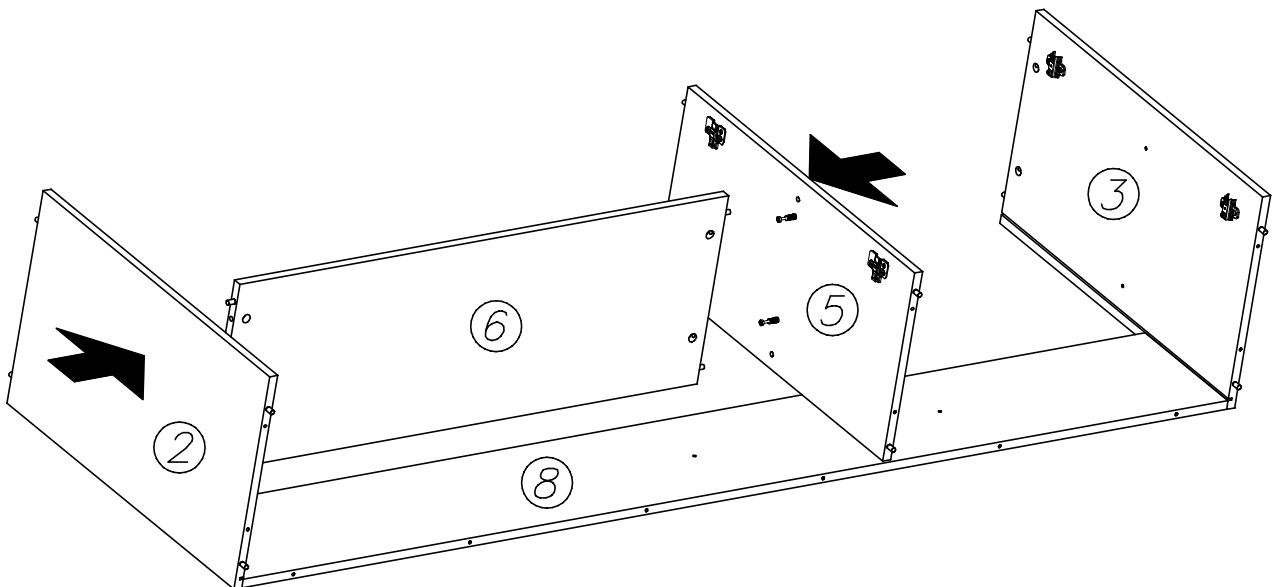
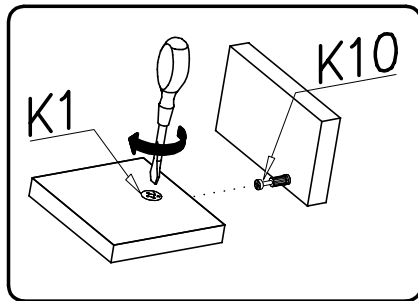

V

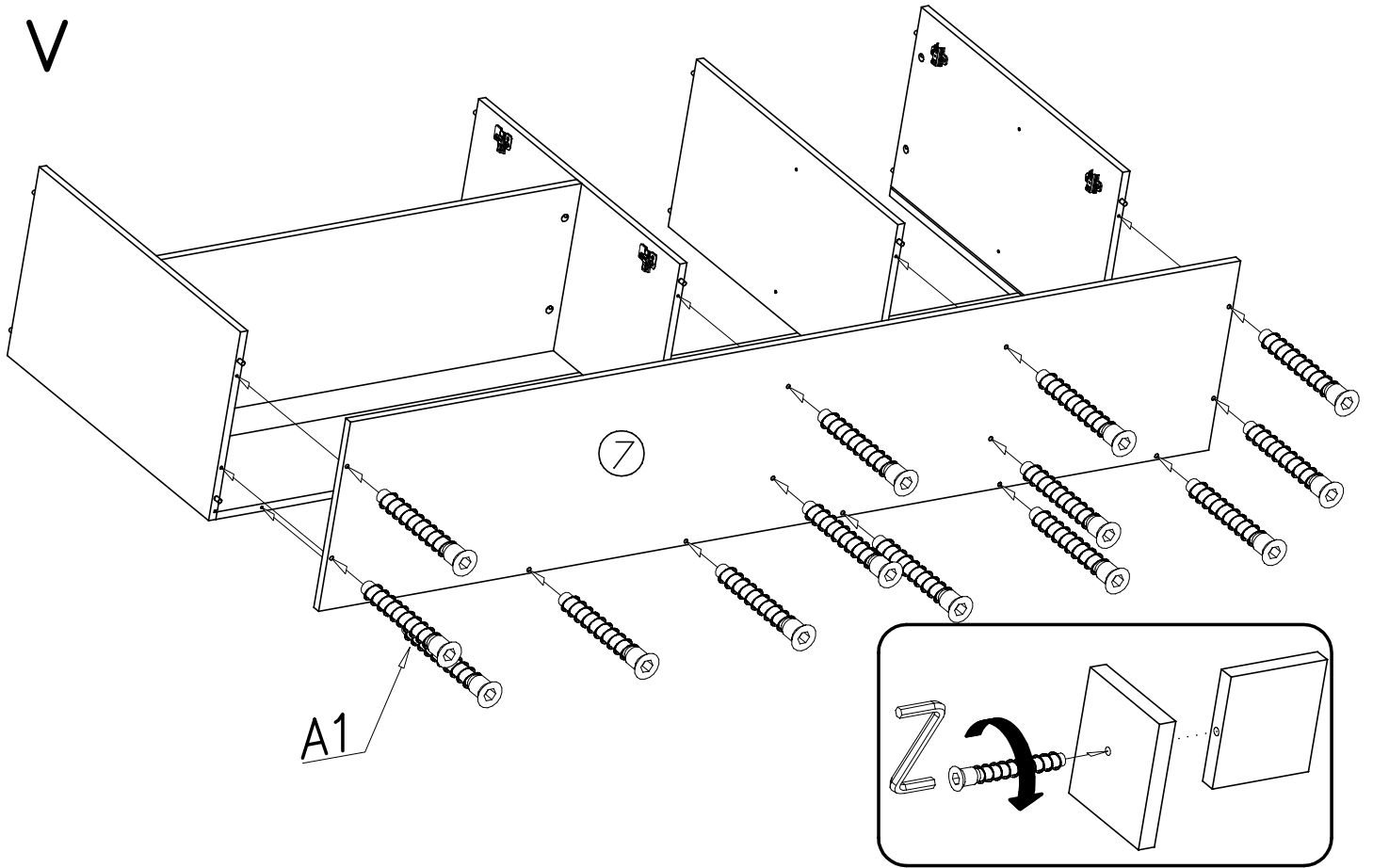

VI

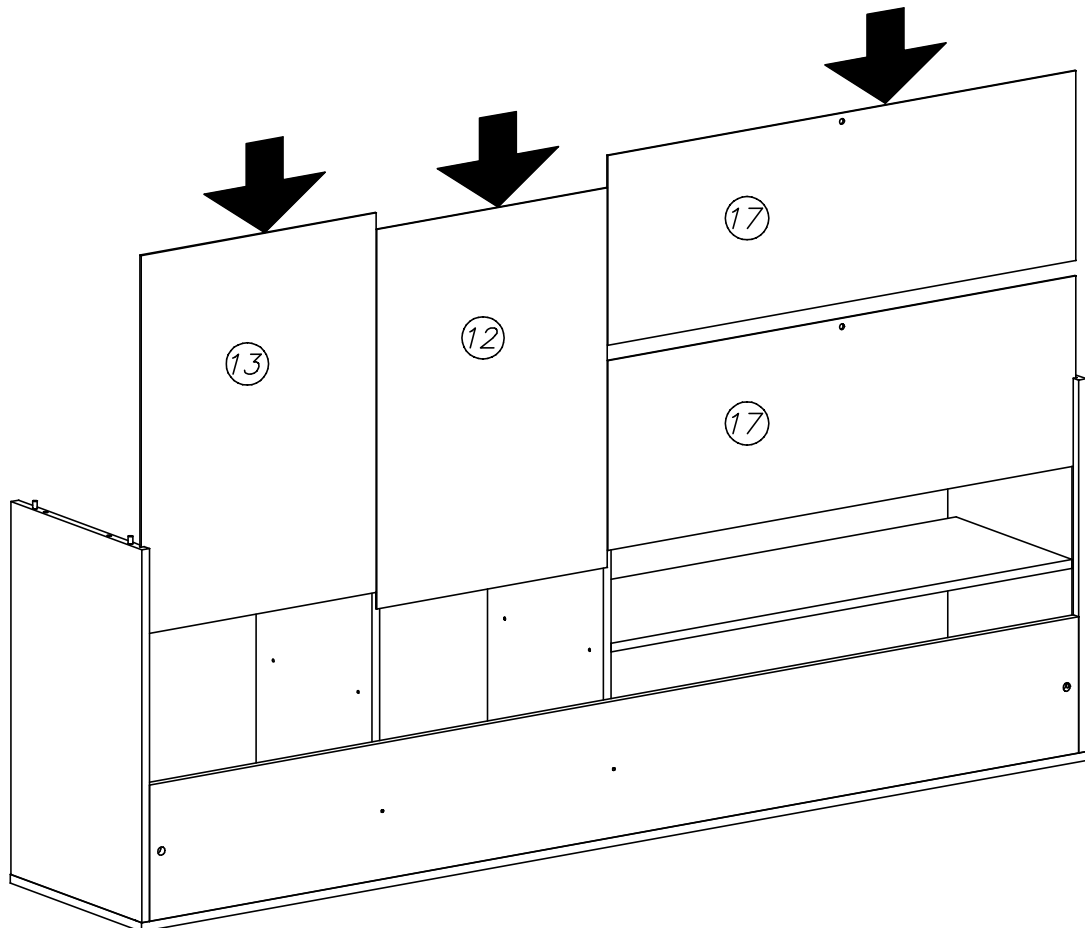

VII

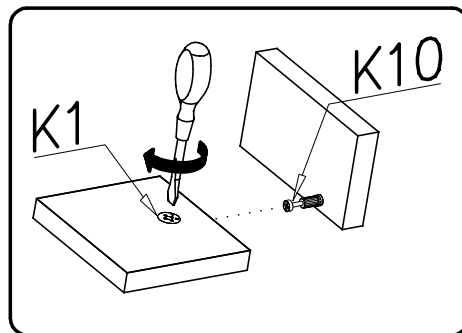
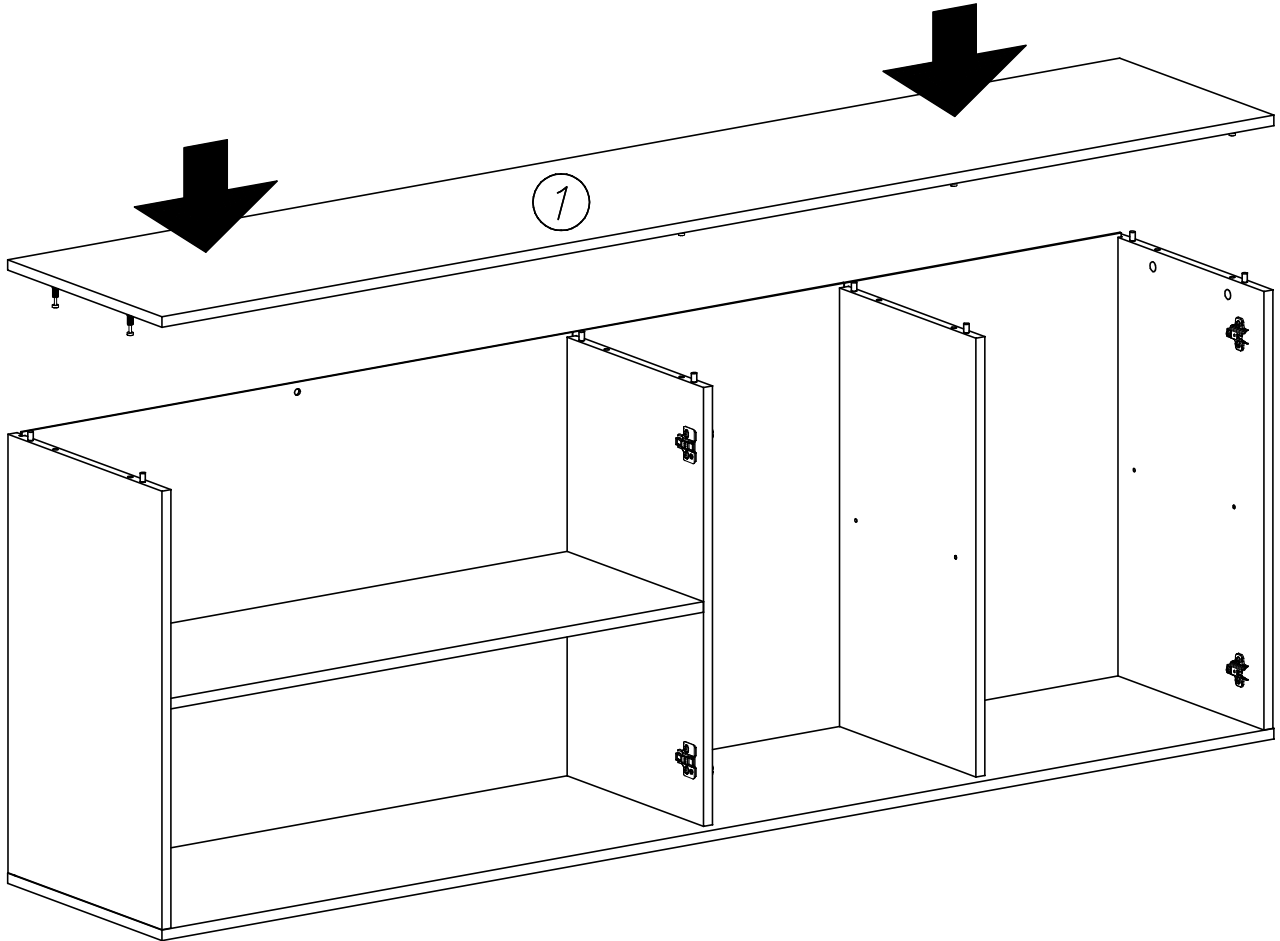

VIII

A=B

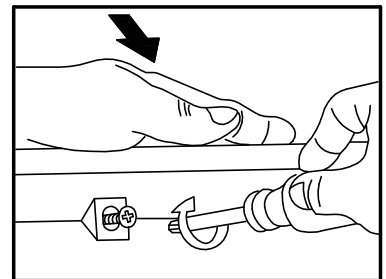
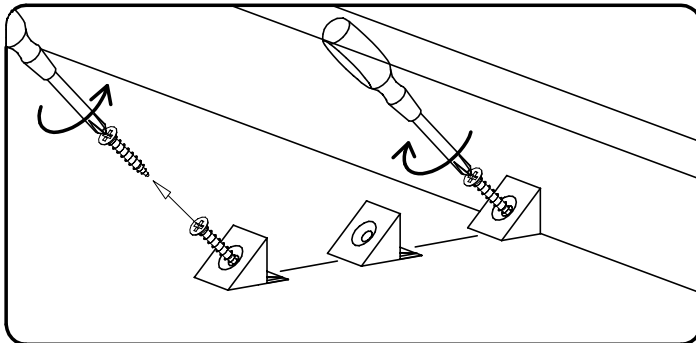
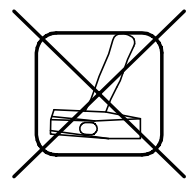
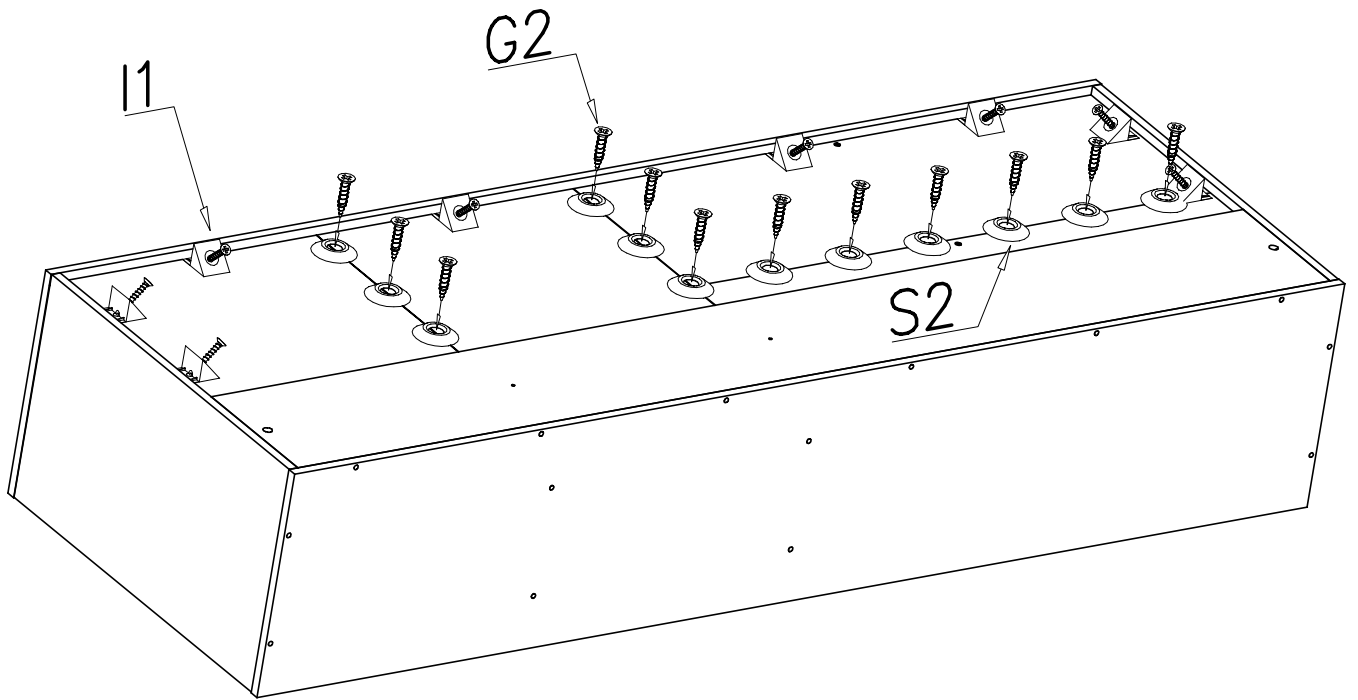
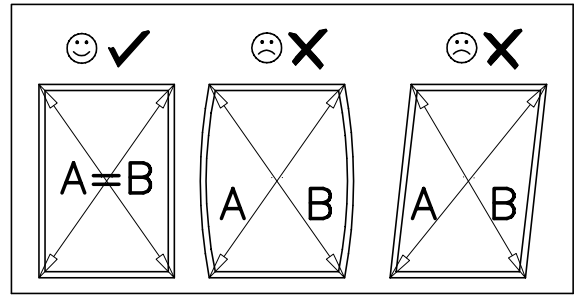

IX ver A

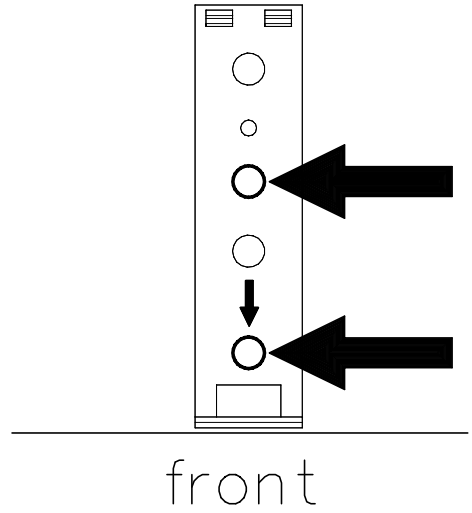
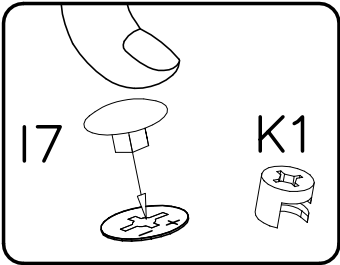
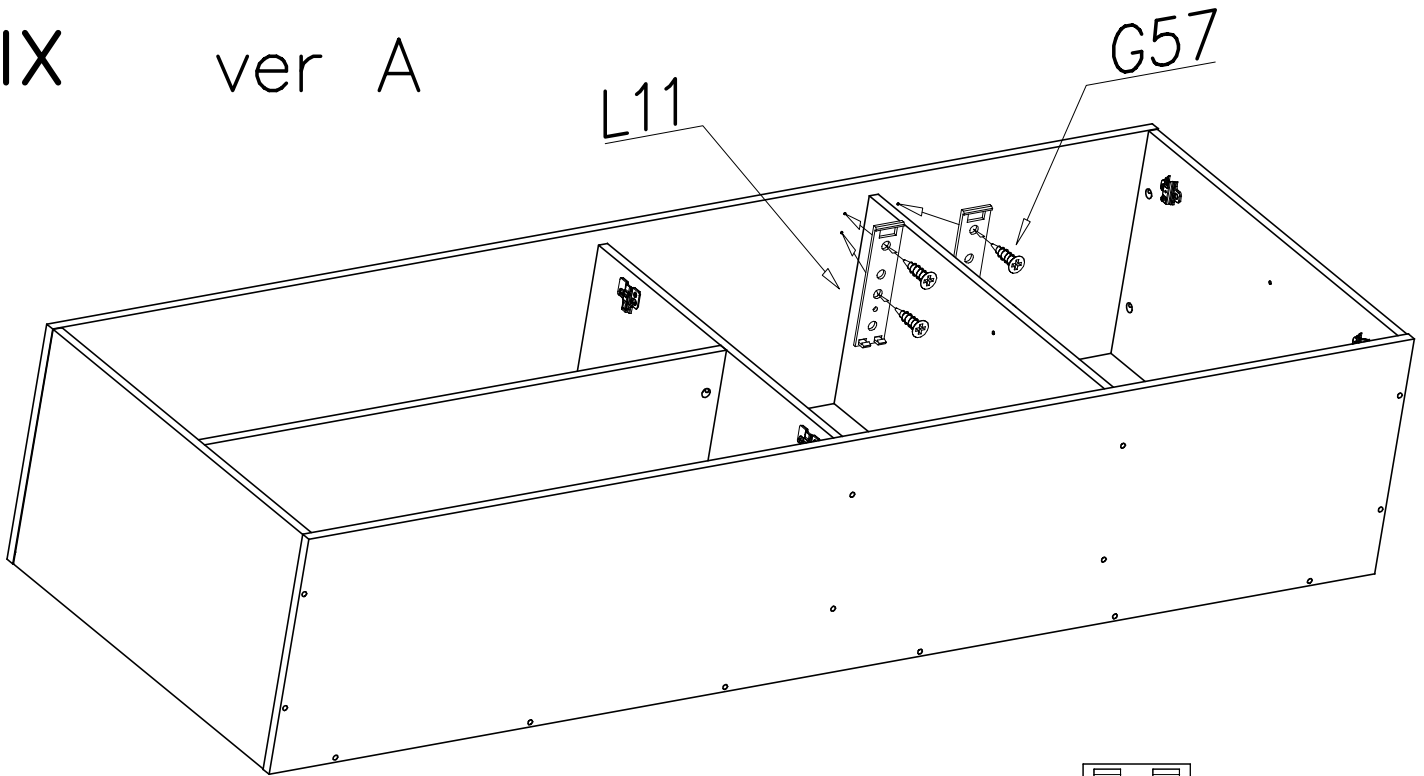

X ver B

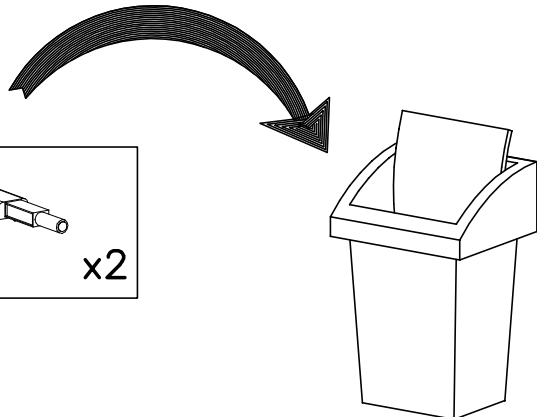
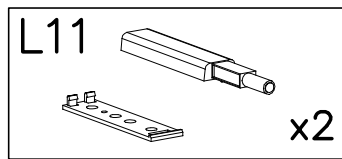

XI ver A

L11

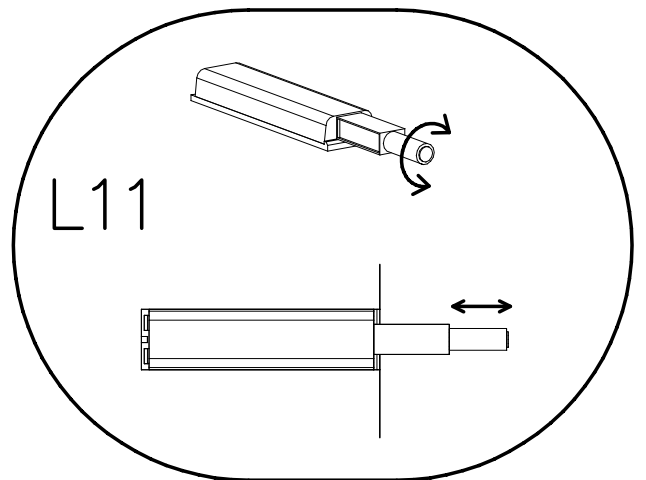
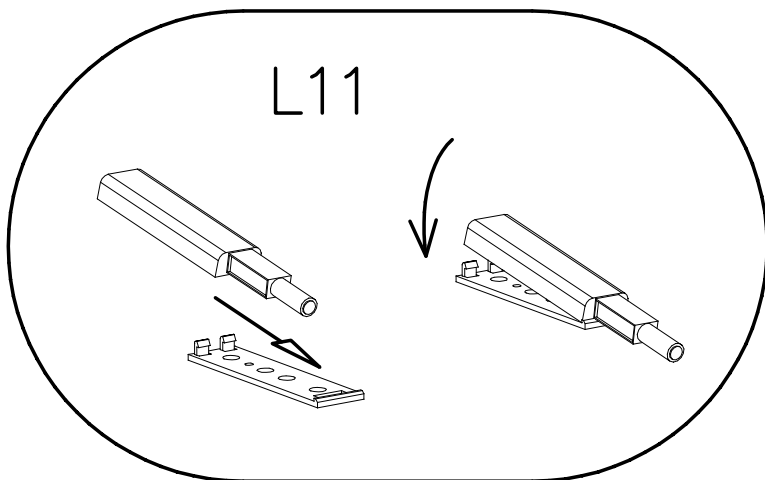
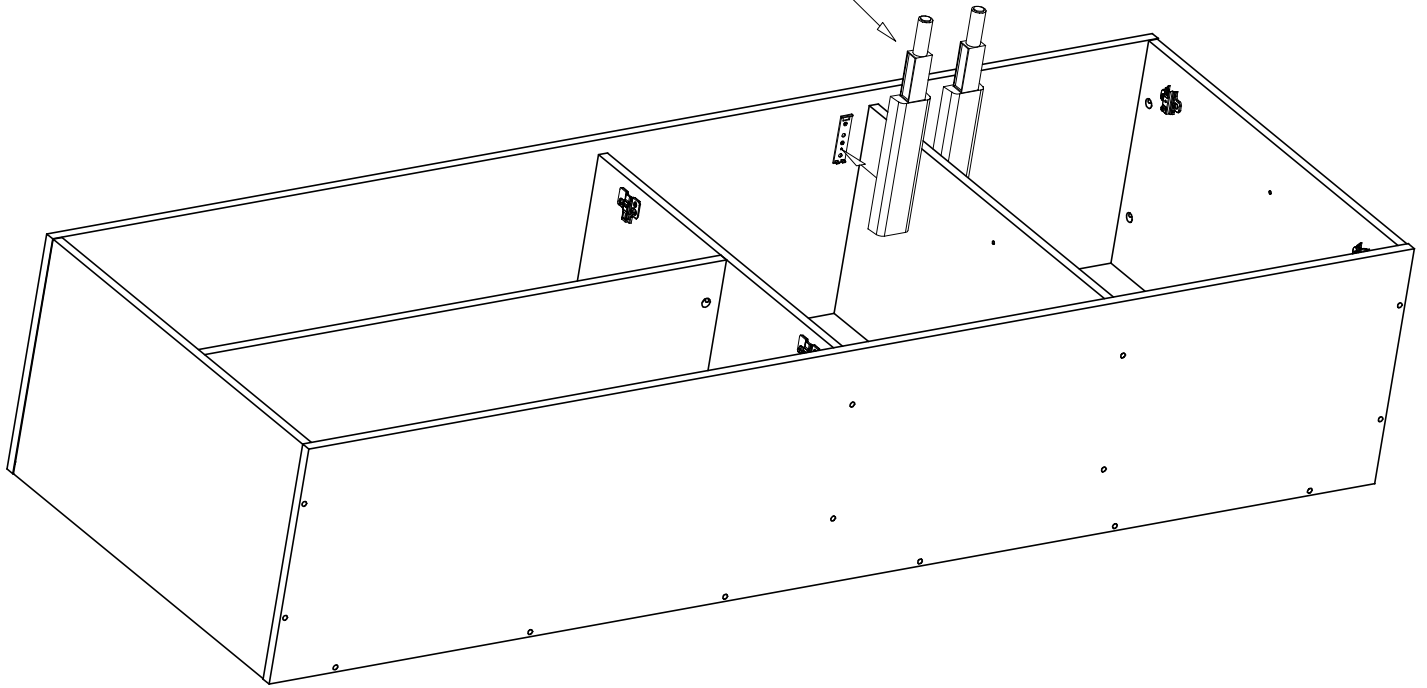

XII

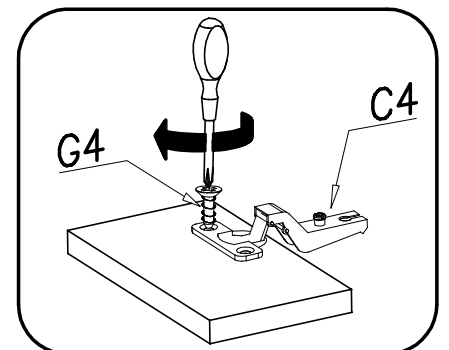
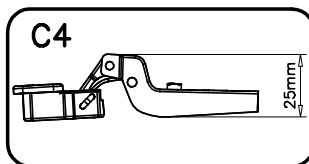
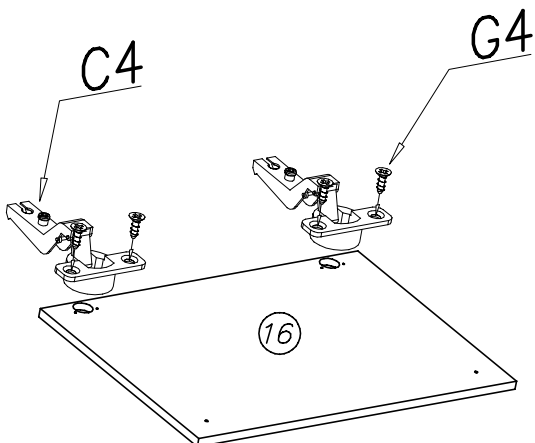
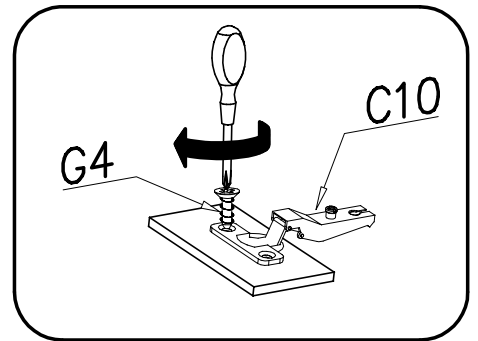
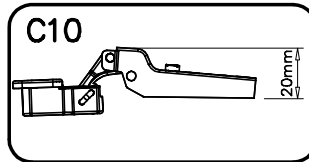
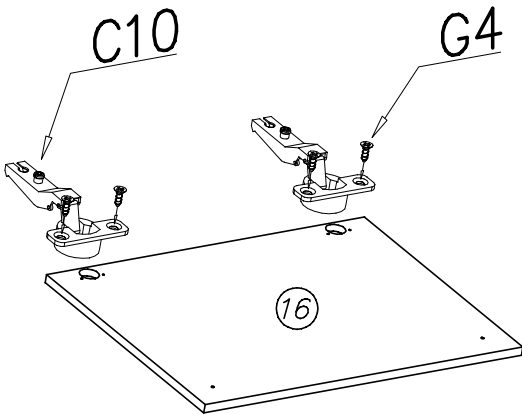
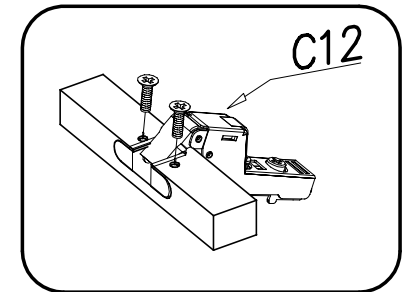
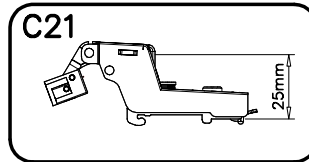
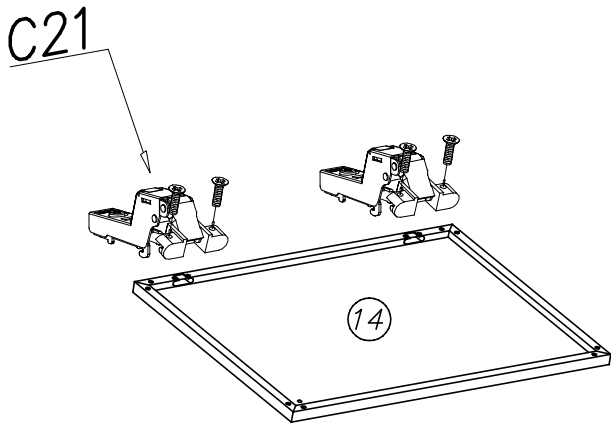
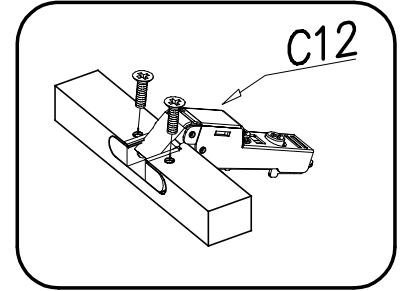
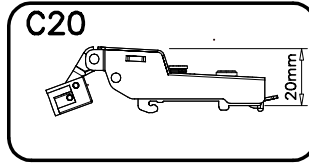
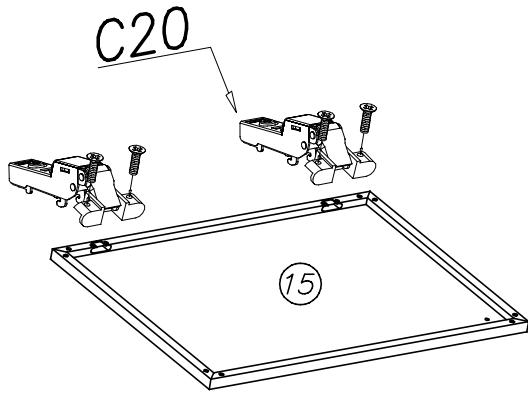

XIII

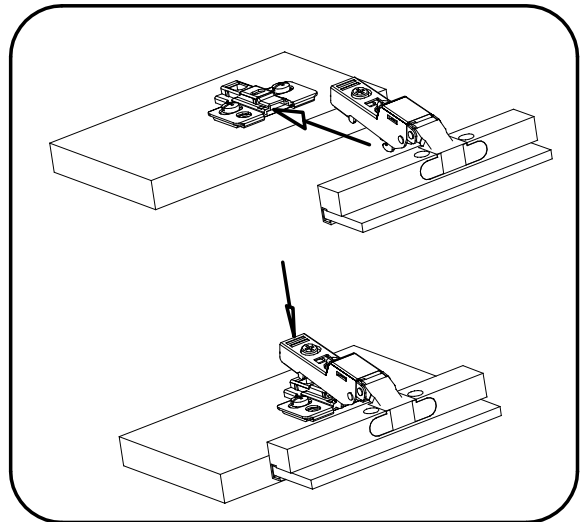
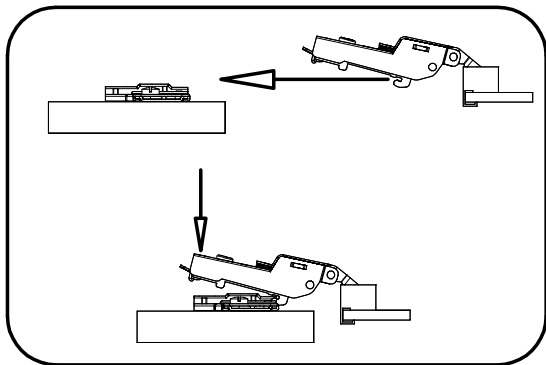
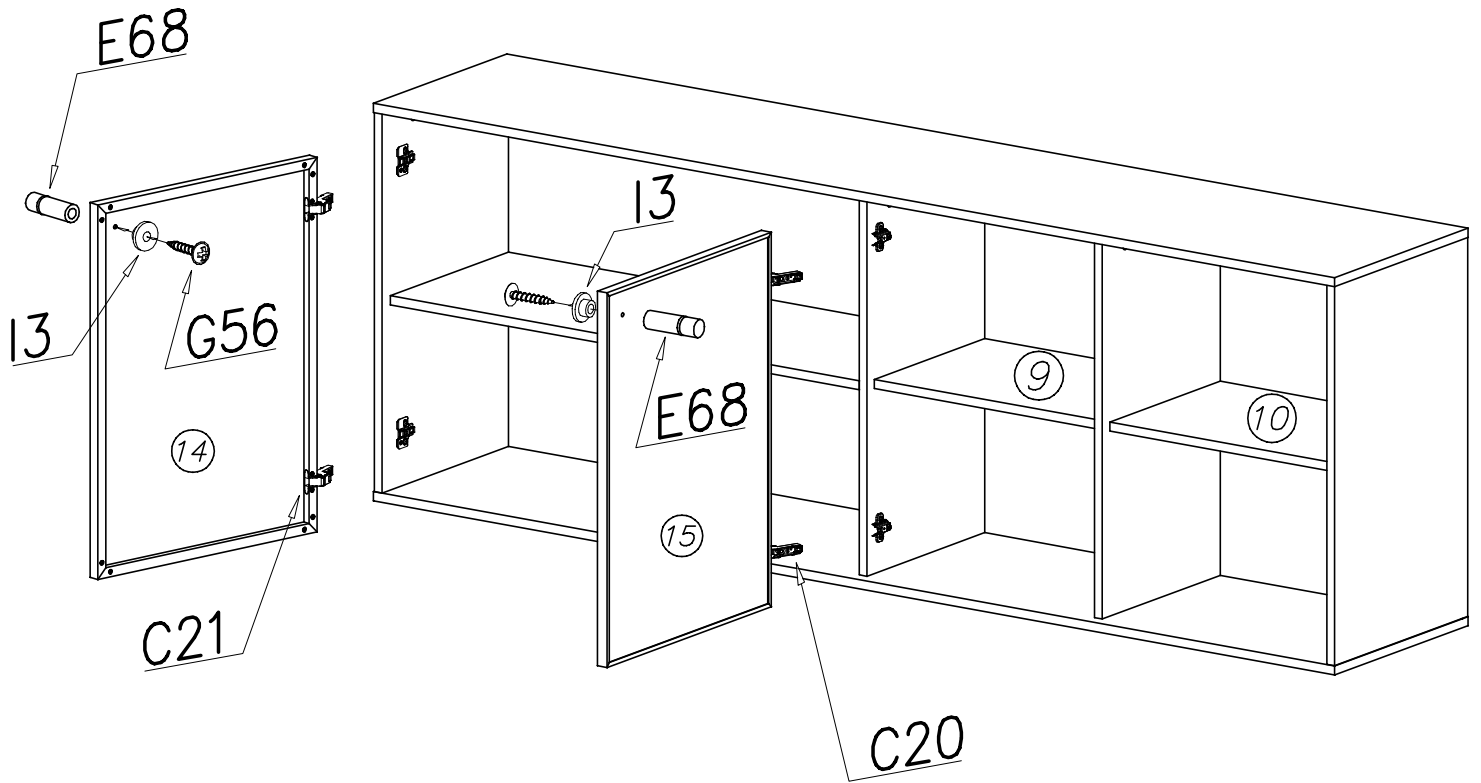
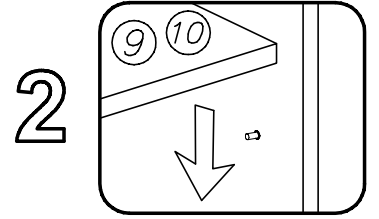
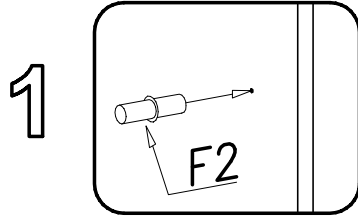

XIV

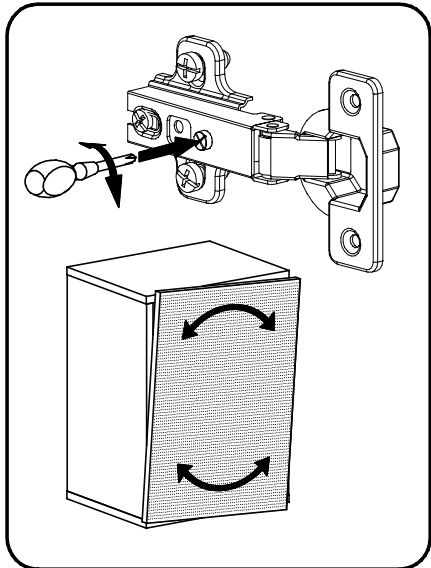
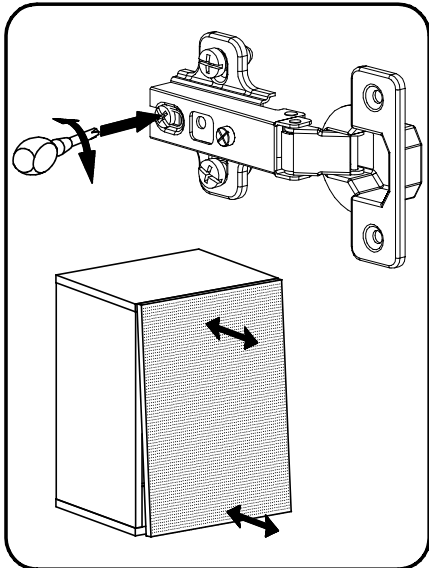
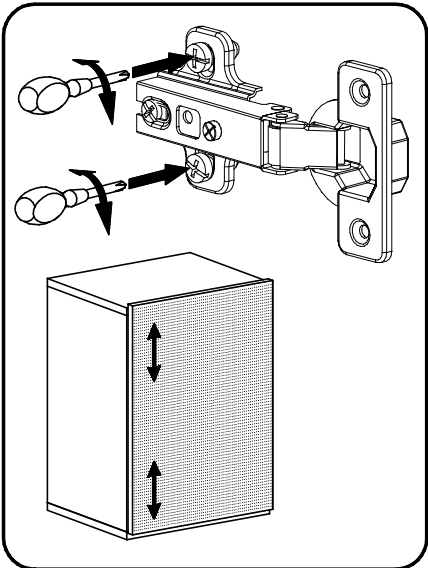
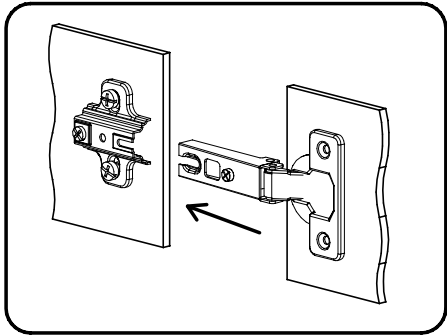
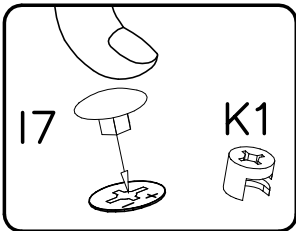
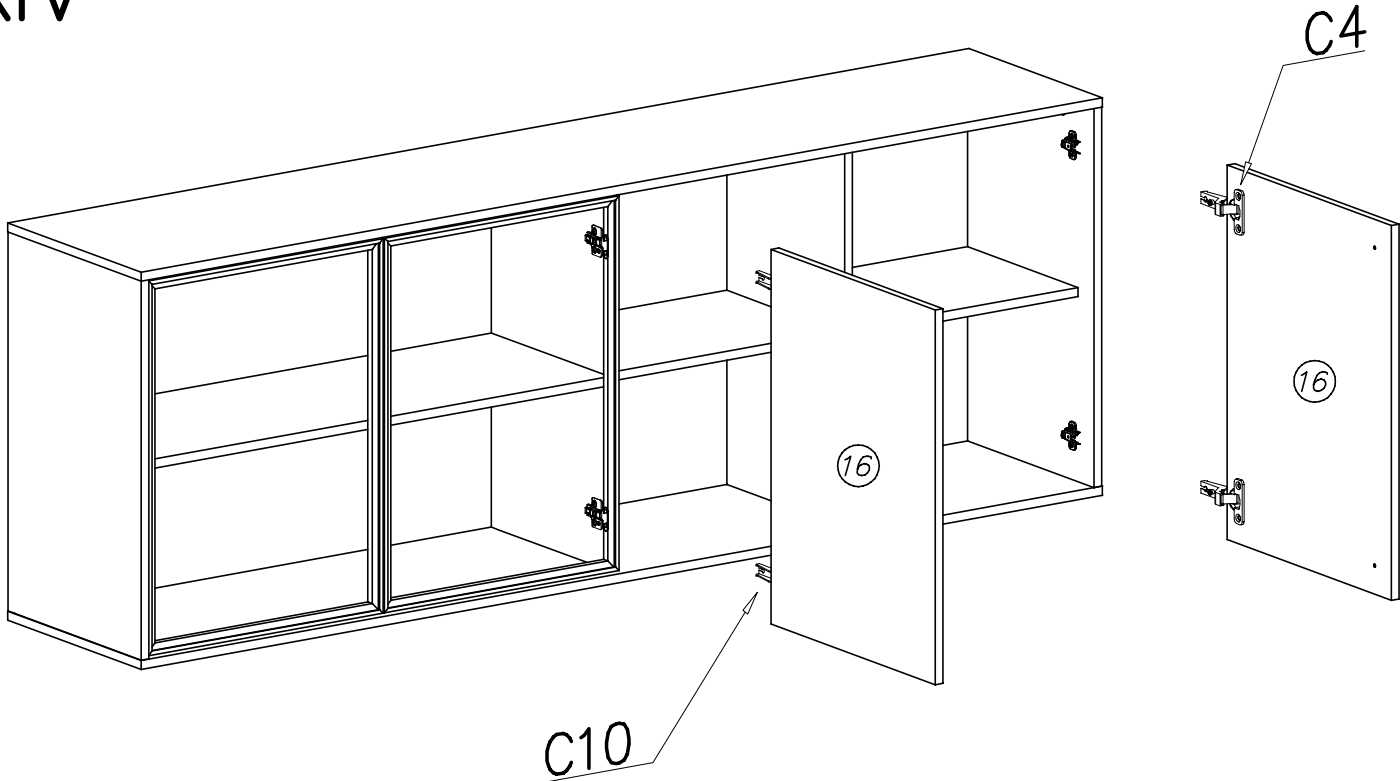

XV

ver B

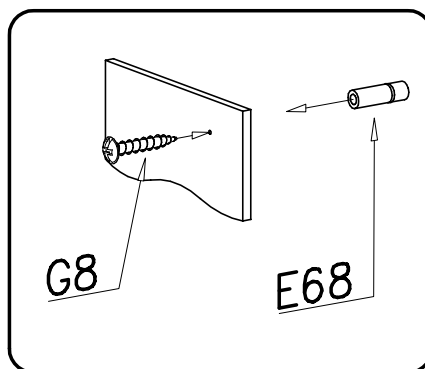
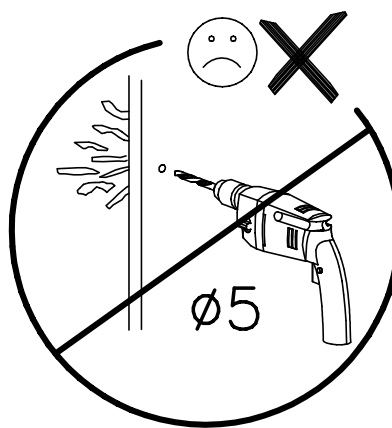
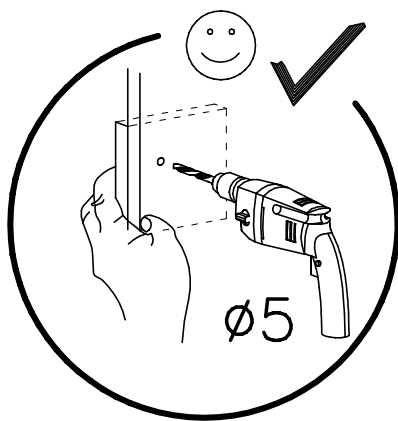
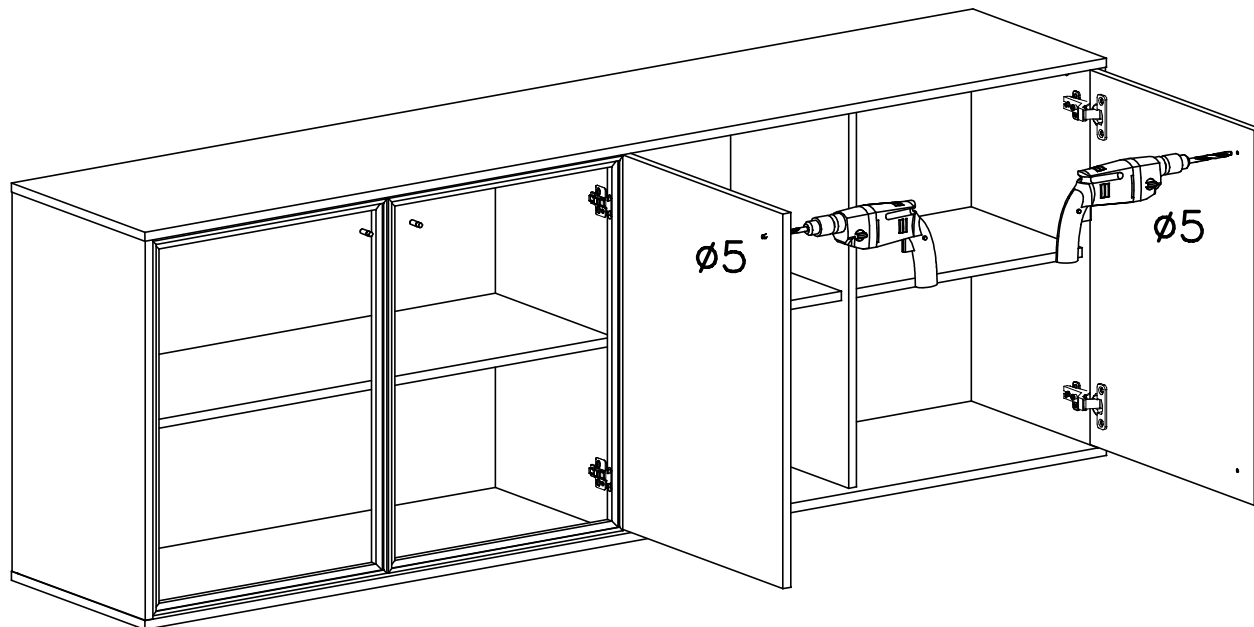



Achtung • Opgelet • Uwaga • Dikkat • Вниманіе •
Attention • Upozorneni • Figyelem • Allenzione • Atentie



D	Überschreiten Sie die angegebenen Maximalbelastungen nicht. Andernfalls kann das Möbelstück beschädigt oder zerstört werden.
GB	Do not exceed the maximum loads specified. Otherwise, the furniture may sustain damage or be irreparably damaged.
NL	Overschrijd de aangegeven maximale belastingen niet. Anders kan het meubelstuk worden beschadigd of vernield.
PL	Nie wolno przekraczać podanych maksymalnych wartości obciążenia. W innym przypadku można mebel uszkodzić lub zniszczyć.
TR	Belirtilen azami yuk degerini asmayiniz, aksi taktirde mobilya parcasi zarar gorebilir veya kullanilamazehale gelebilir.
RU	Не допускается превышение указанных максимальных нагрузок. В противном случае возможно повреждение или разрушение мебели.
FR	Ne dépassez pas les charges maximum indiquées. Sinon, le meuble peut être endommagé ou détruit.
CZ	Nepřekračujte uvedené maximální zatížení. V opačném případě může dojít k poškození nebo zničení nábytku.
HU	Tartsa be az engedélyezett maximális terhelhetőséget/teljesítményt. Különben a bútor és annak alkatrészei megsérülhetnek, tönkre mehetnek.
IT	Non superare il carico massimo indicato. Altrimenti il mobile rischia di rovinarsi o frantumarsi.
RO	Nu depasiti sollicitarile maxime specificate. Altfel puteti sa deteriorati sau sa distrugeti piesa de mobilier.
SK	Neprekročte uvedené maximálne zaťaženia. V opačnom prípade sa môže nábytok poškodiť alebo zničiť.

D	Die Befestigung des Möbelstückes an der Wand muss von einer fachkundigen Person vorgenommen werden, da für die Montage an die Wand angepasste Dübel erforderlich sind.
GB	A qualified professional is required when mounting furniture to the wall since dowels corresponding to the wall are required for this.
NL	Een vakkundige persoon dient het meubelstuk aan de muur te bevestigen; voor de montage aan de muur zijn immers aangepaste pluggen vereist.
PL	Mocowanie mebla do ściany mogą przeprowadzić wyłącznie wykwalifikowane osoby, z uwagi na zastosowanie odpowiednio dopasowanych kołków do rodzaju ściany.
TR	Mobilya parçasının duvara sabitlenmesi, duvar montajı için özel uyarlanmış dübeller gerektirdiğinden bu iş sadece bu konuda uzman bir kişi tarafından gerçekleştirilmelidir.
RU	Поскольку для монтажа на стене необходимо использовать специальные дюбели, мебель должна быть закреплена на стене квалифицированным персоналом.
FR	La fixation du meuble contre le mur doit être effectuée par une personne compétente car, pour le montage mural, il faut utiliser des chevilles adaptées.
CZ	Montáž nábytku na stěnu musí provést odborník, protože k montáži na stěnu jsou zapotřebí upravené hmoždinky.
HU	A bútorelemek falra rögzítését szakembernek kell végeznie, mert a rögzítéshez megfelelő tiplit kell használni.
IT	Il fissaggio del mobile alla parete deve essere eseguito esperte, dato che occorrono tasselli adeguati.
RO	Fixarea la perete a piesei de mobilier se realizeaza numai de catre personal competent, deoarece montajul de perete necesita dibluri adecvate.
SK	Upevnenie nábytku na stenu musí vykonať odborník, nakoľko sú pre montáž na stenu potrebné vhodné hmoždinky.



Uwaga • Upozornění • Achtung • Attention • Caution • Figyelem
 Attenzione • Opgelet • Внимание • Atenție • Upozornenie • Dikkat

