







# ASSEMBLY INSTRUCTION

NO.	PARTS LIST		Q'TY
A		TABLE TOP	1PC
B		TABLE LEG	4PCS

NO.	HARDWARE LIST		Q'TY
C		WRENCH 5MM	1PC
D		BOLT Ø5/16"*2-1/2"	8PCS
E		LOCK WASHER Ø5/16"	8PCS
F		FLAT WASHER Ø5/16"*22MM	8PCS

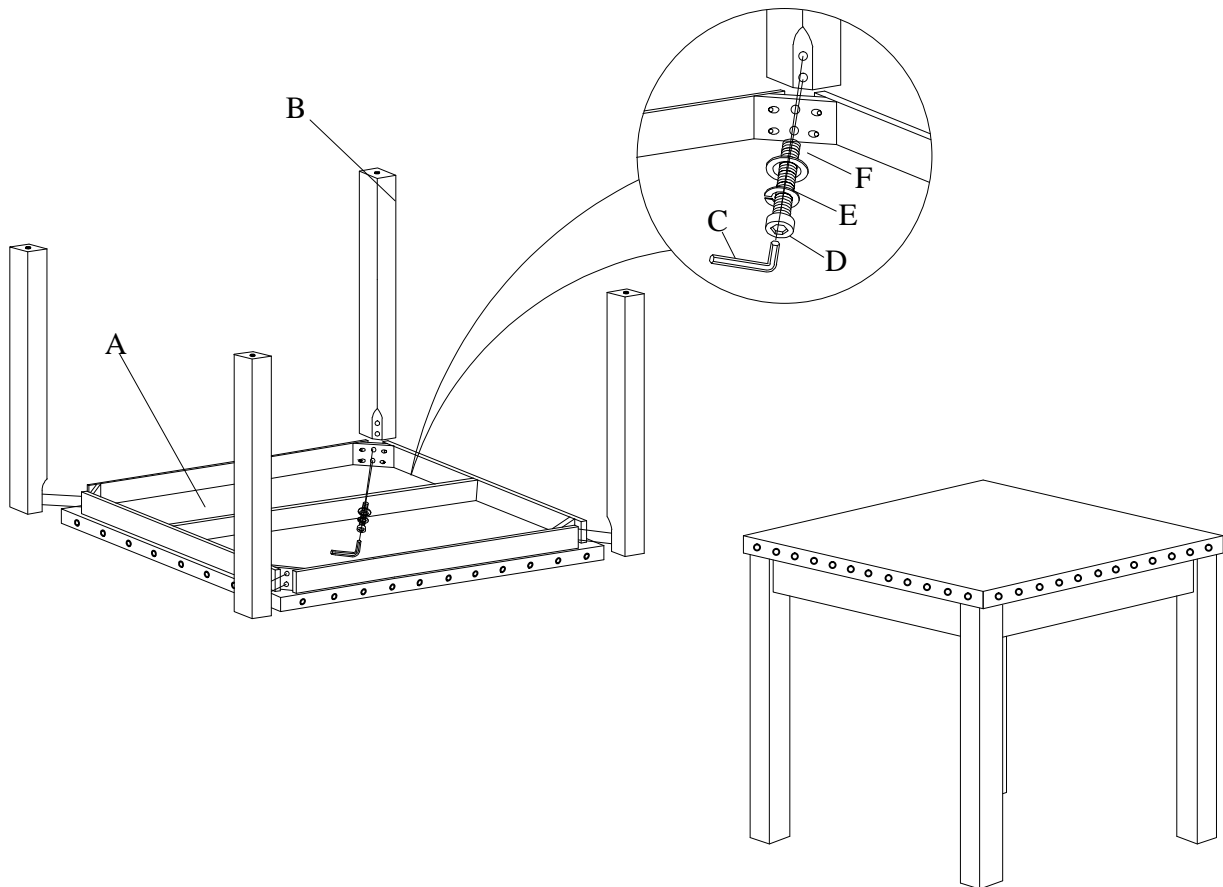

Caution: Please do not tighten all bolts until the table is completely assembled!

MADE IN VIETNAM