

Installation & Assembly

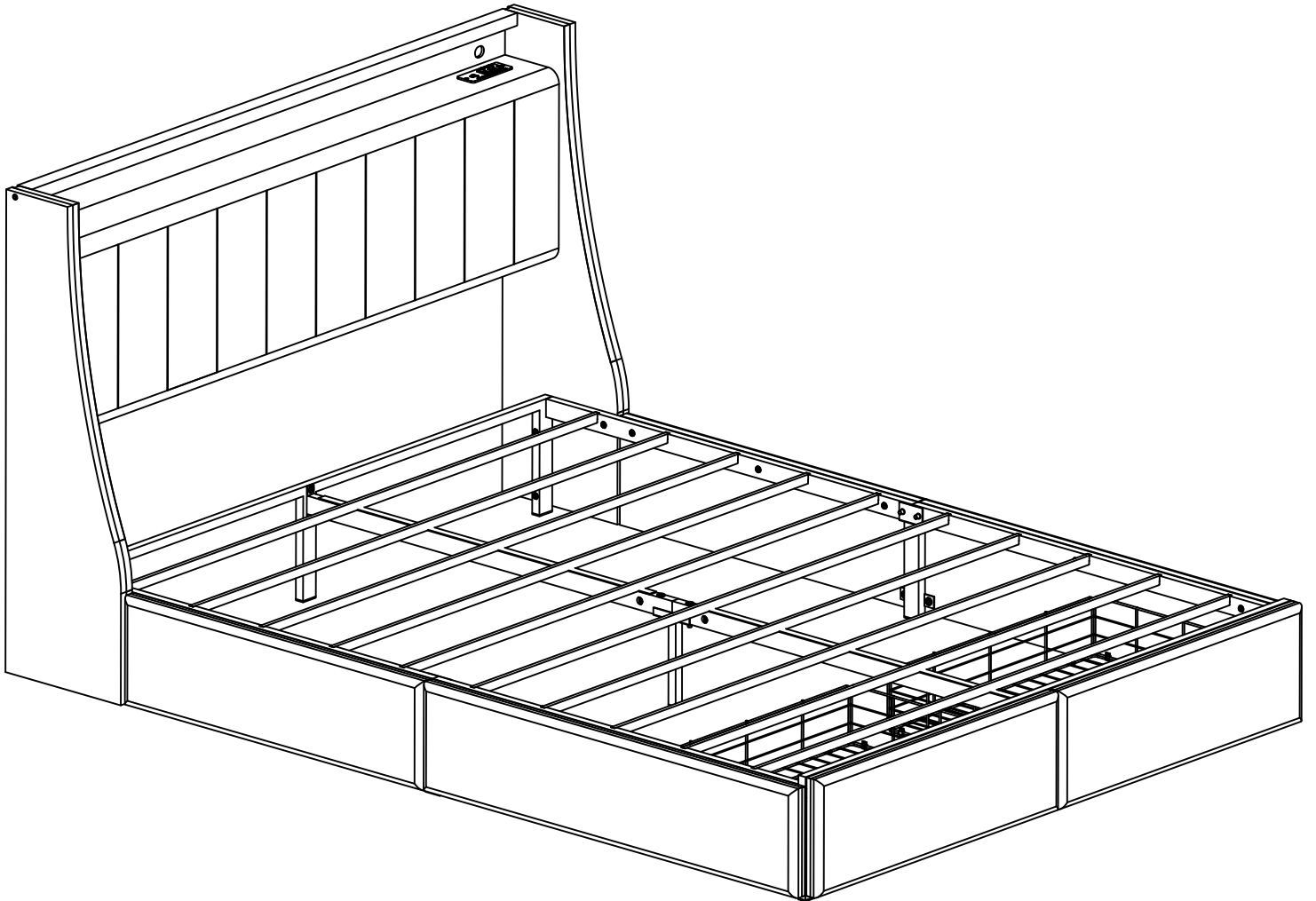

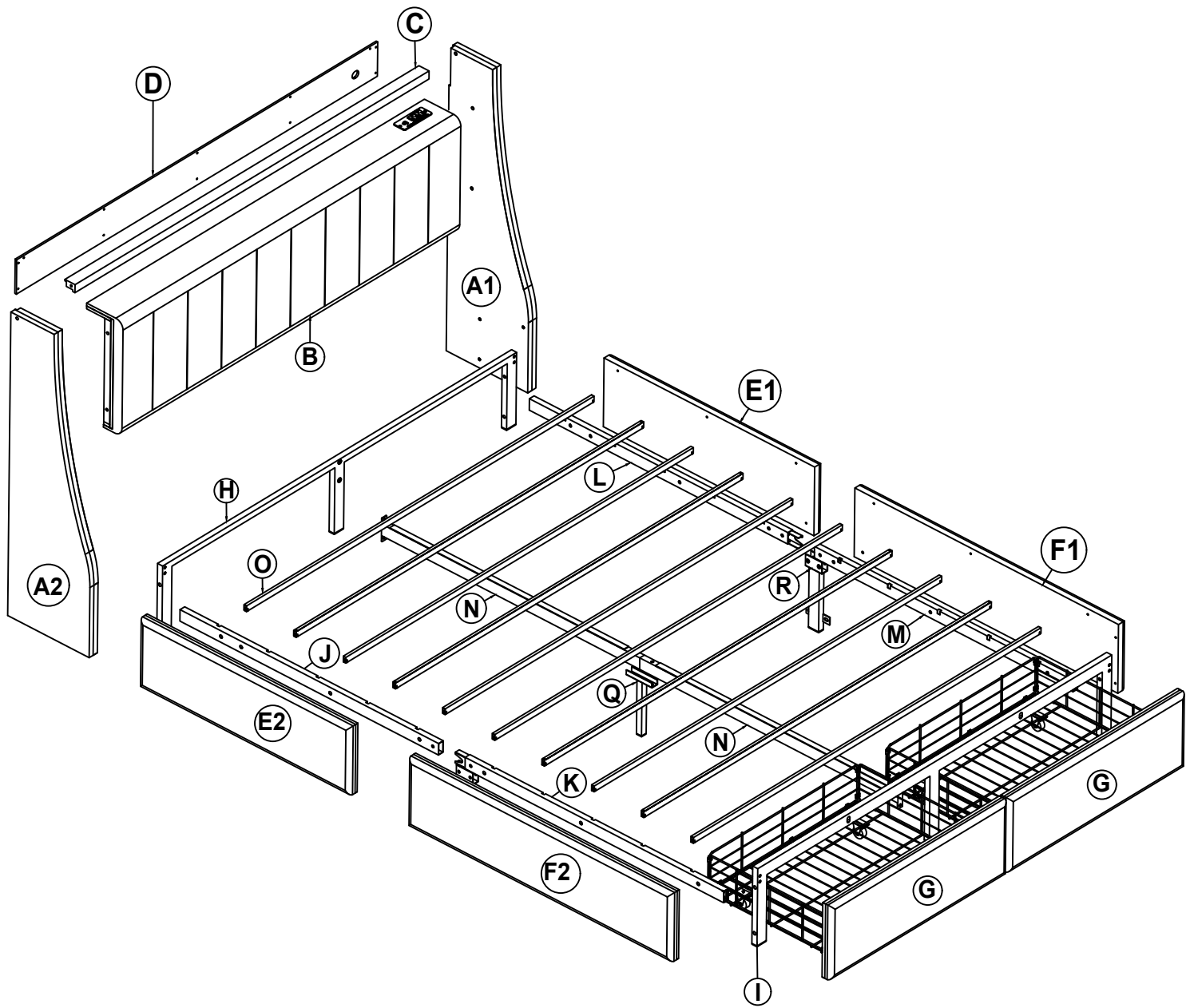

Parts List:

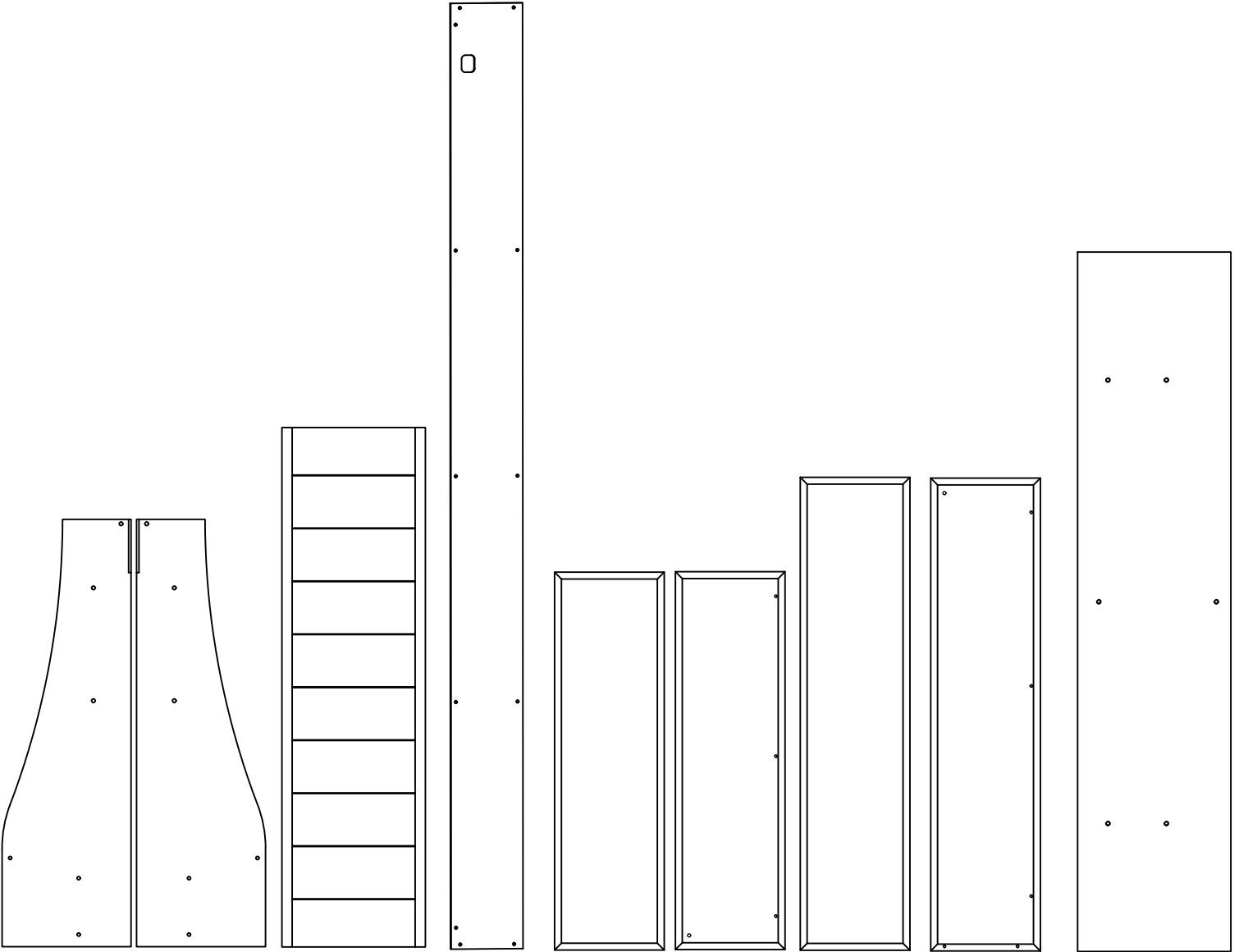

A2

1pcs

A1

1pcs

B

1pcs

D

1pcs

E1

1pcs

E2

1pcs

F1

1pcs

F2

1pcs

G

2pcs

Parts List:

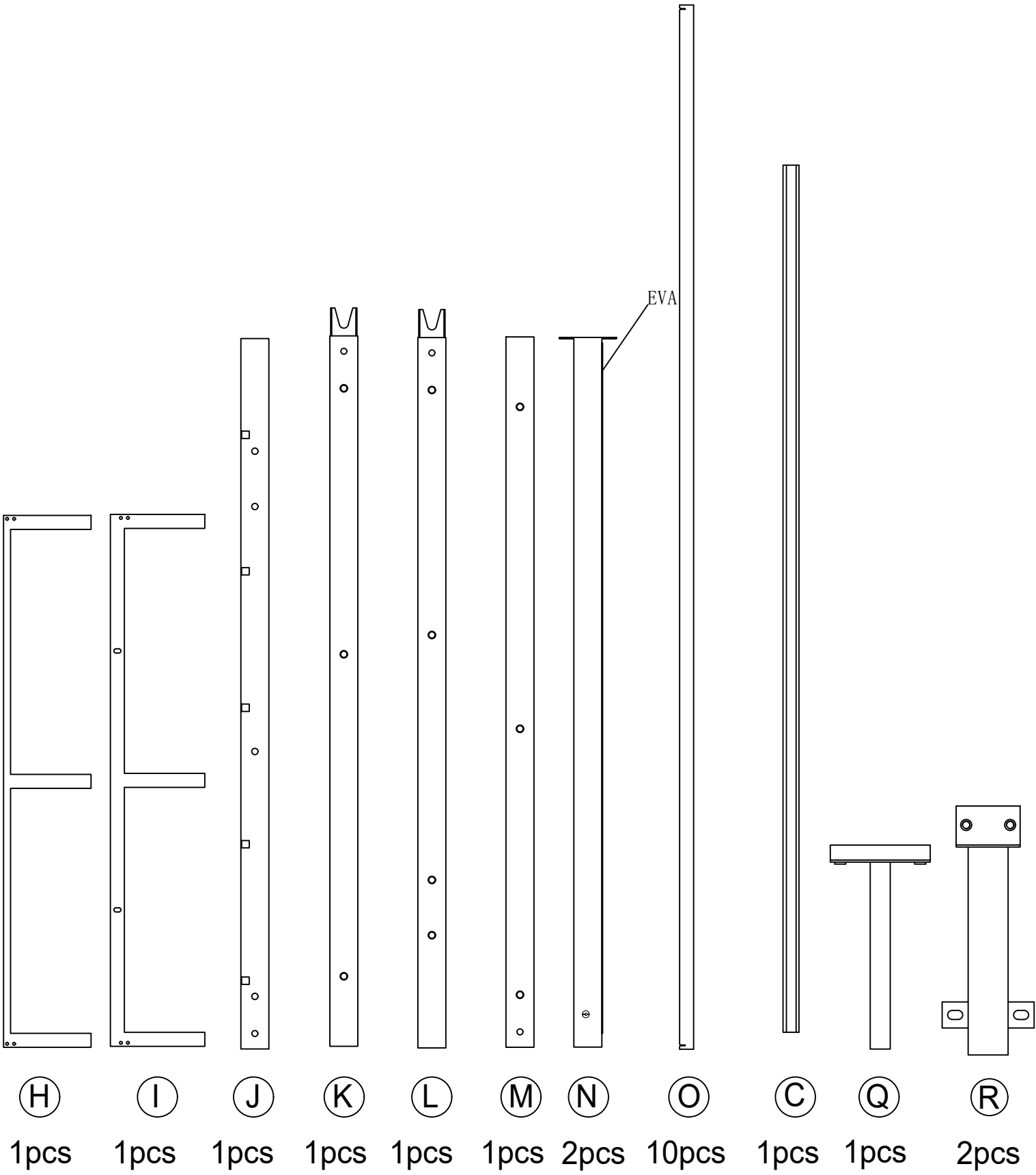

Parts List:

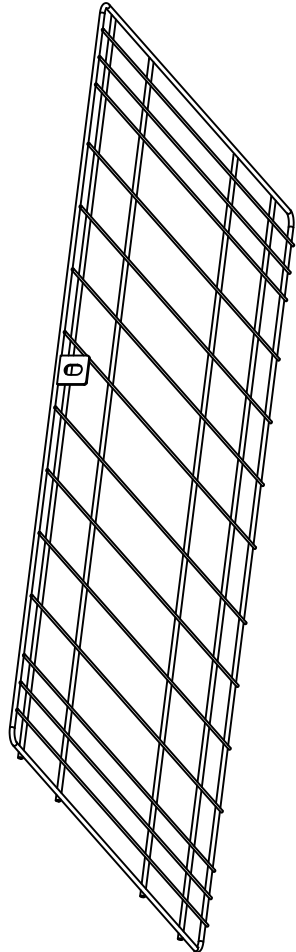

Z4
2pcs



Z2
4pcs

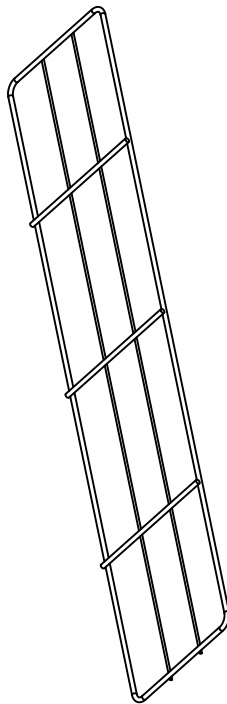

Z3
2pcs



U1
1pcs

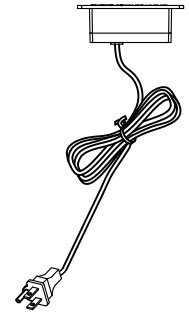

U3
1pcs

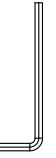

W
1pcs



Washer Ø6xØ18mm



X
2pcs



M6x40mm



T3
4pcs



M4x15mm



V
14pcs



M8x35mm



Y1
12pcs



M6x10mm



Z8
2pcs



M6x45mm



T4
4pcs



M6x15mm



T1
14pcs



M8x55mm



Y2
2pcs



M6x50mm



T5
8pcs



M6x30mm



T2
12pcs



M8x15mm



Y3
4pcs

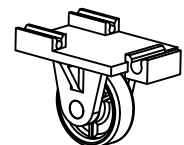

Z5
8pcs



Q1
20pcs

1.1

Step 1

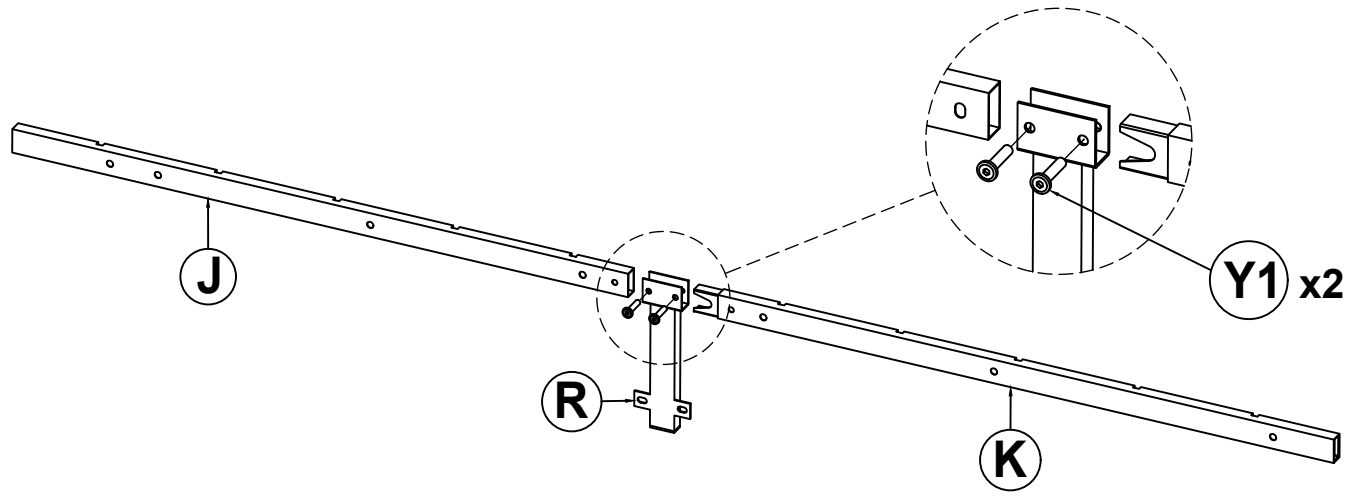

1.2

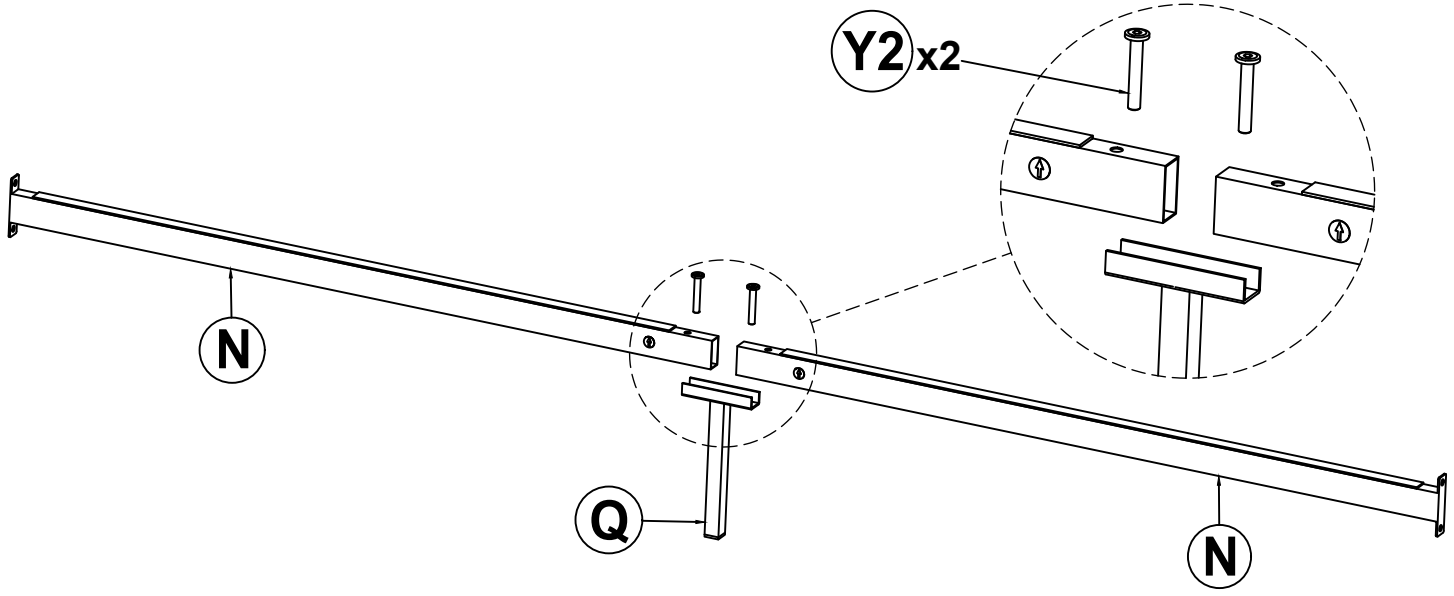

1.3

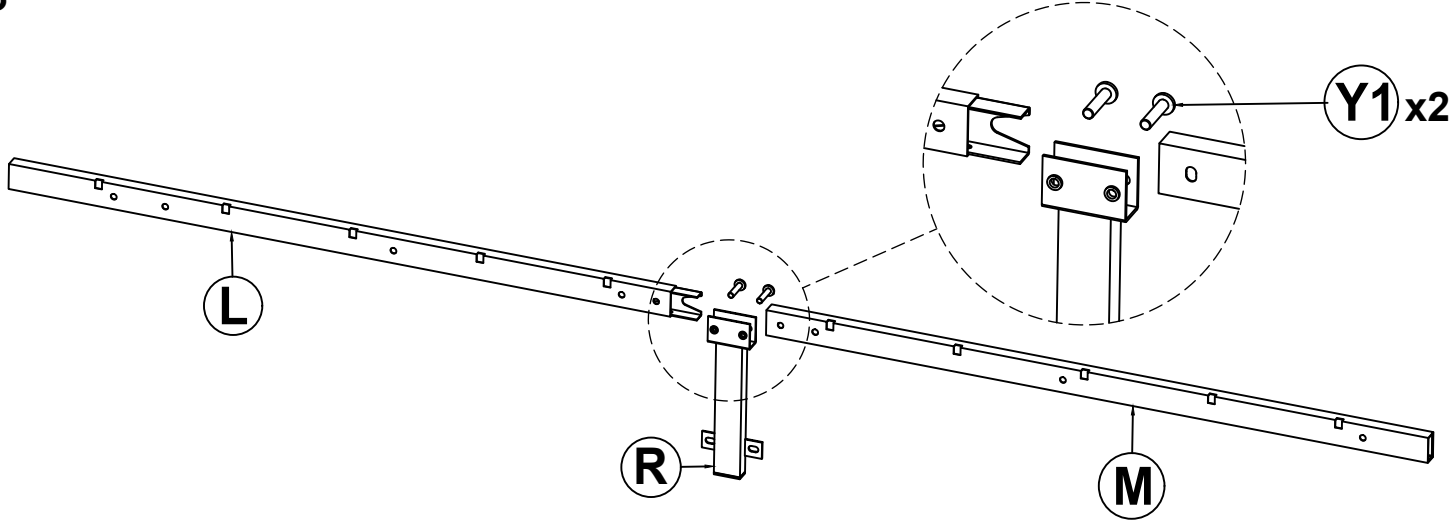

2.1

Step 2

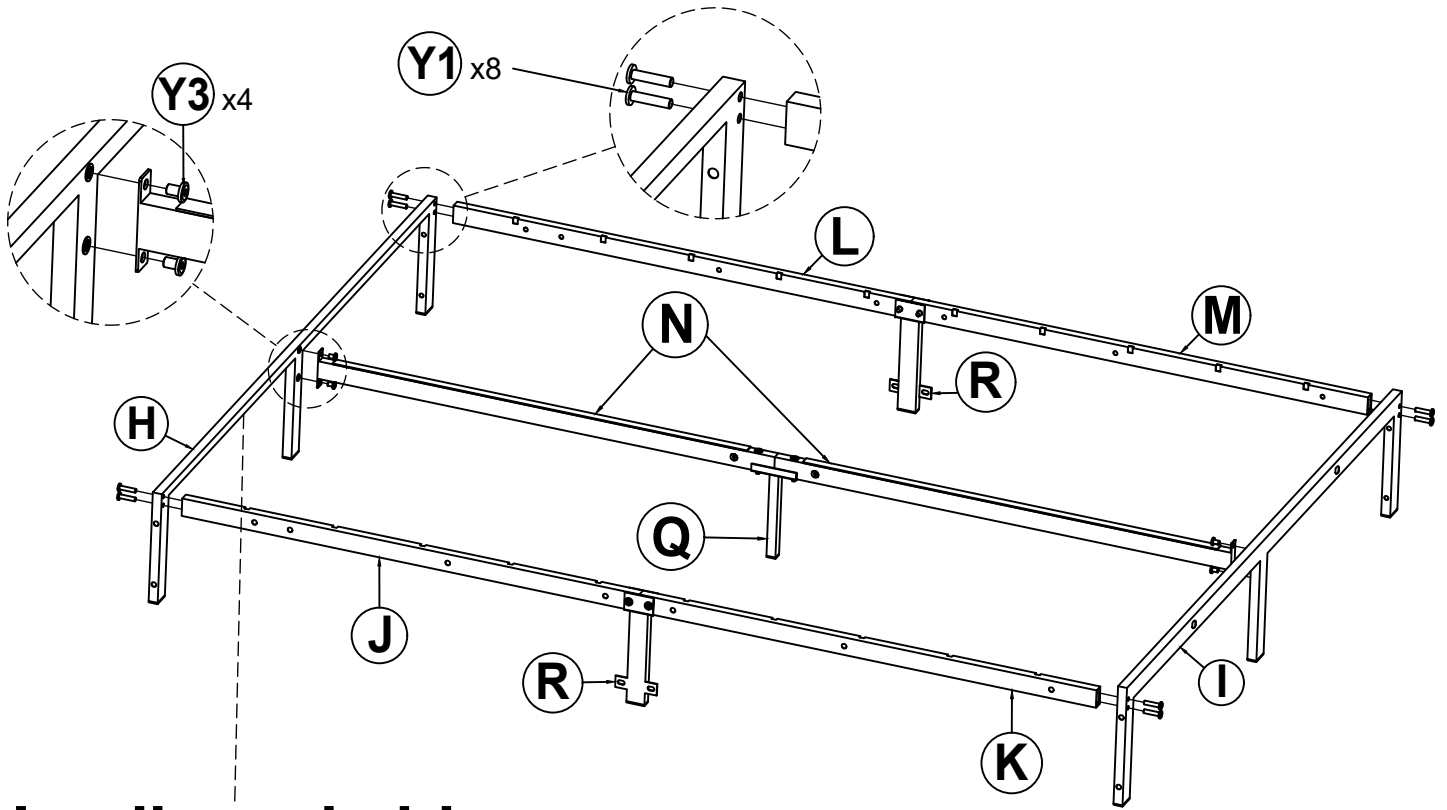

Headboard side

2.2

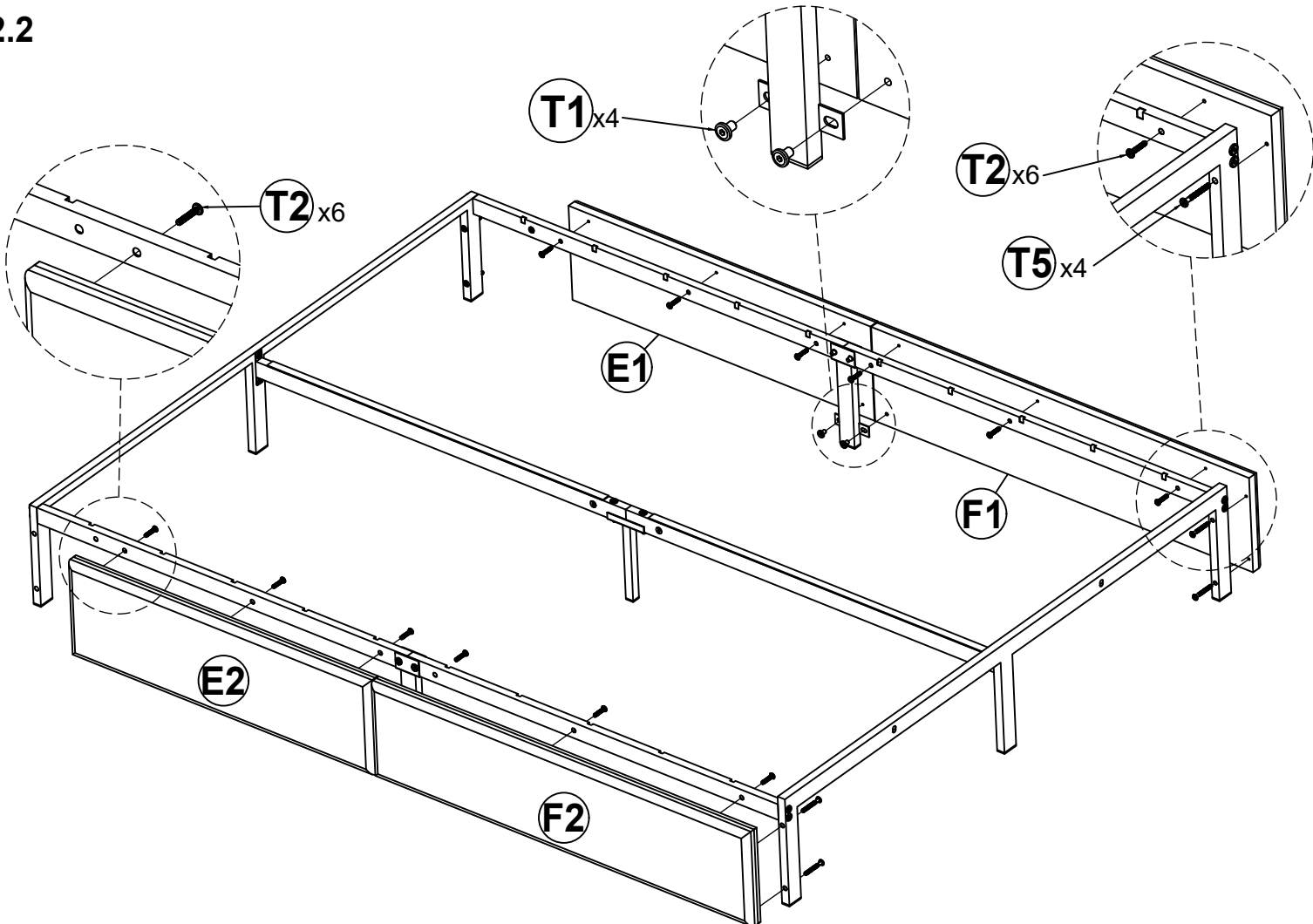

Step 3

3.1

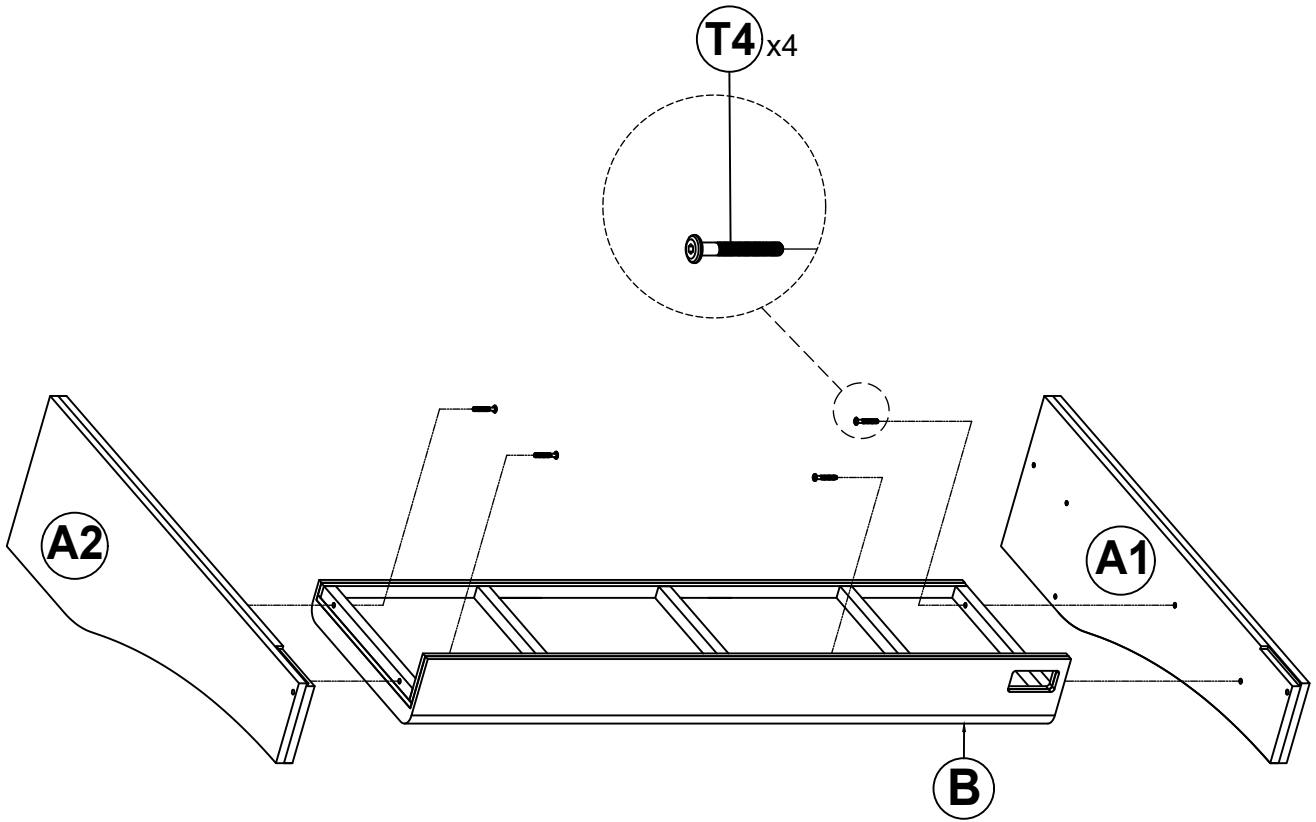

3.2

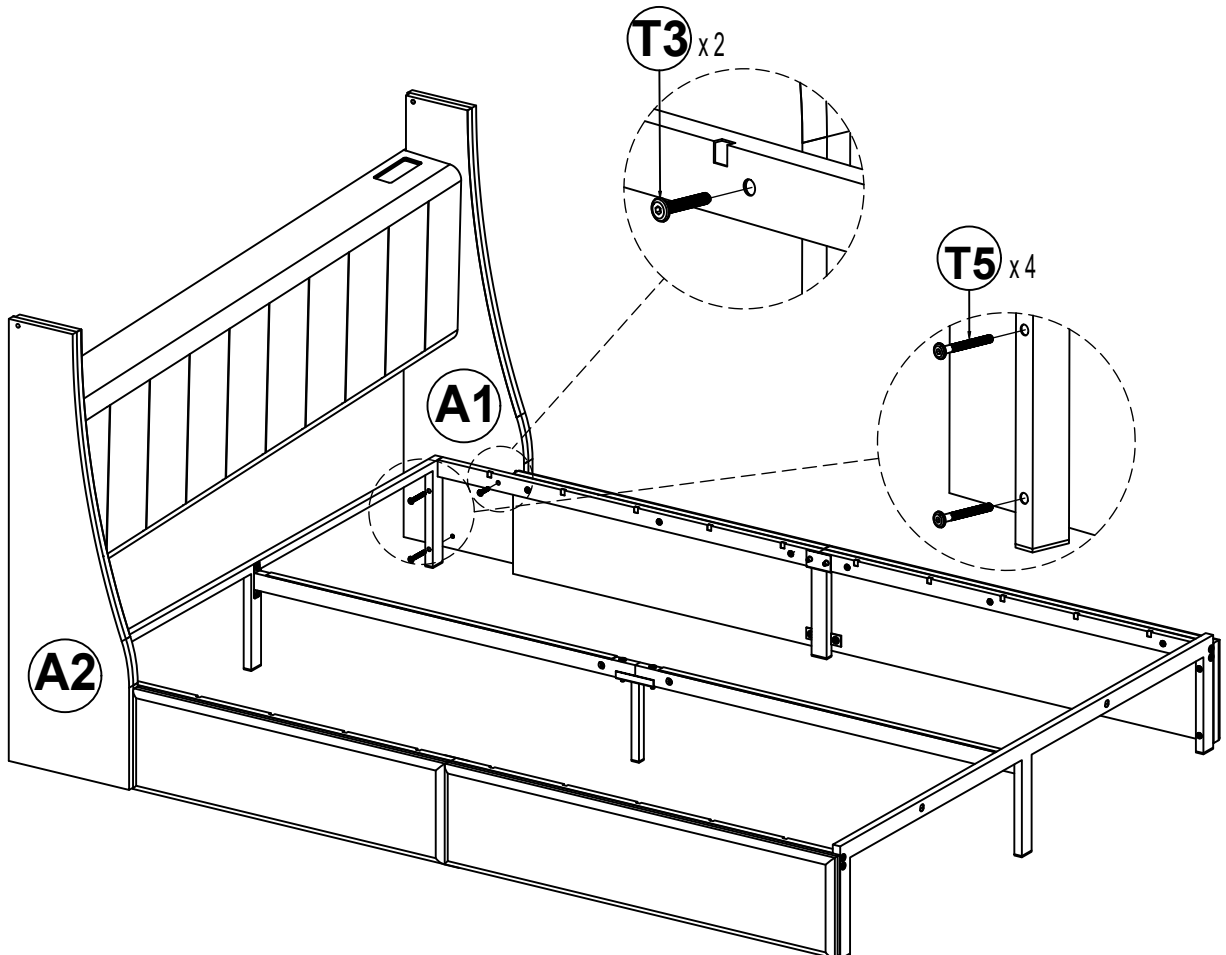

Step 4

4.1

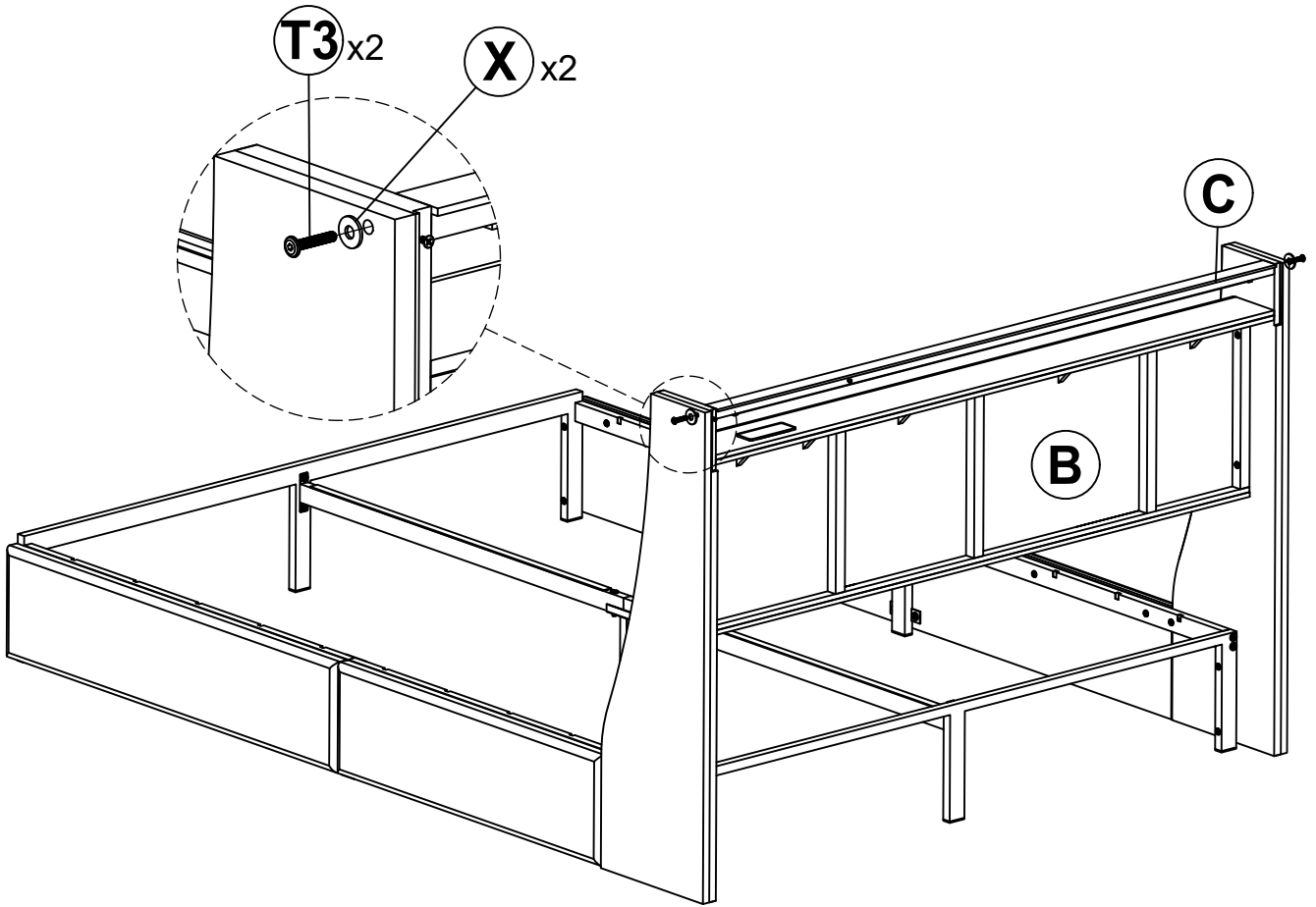

4.2

We suggest using drill machine to install "V" screw

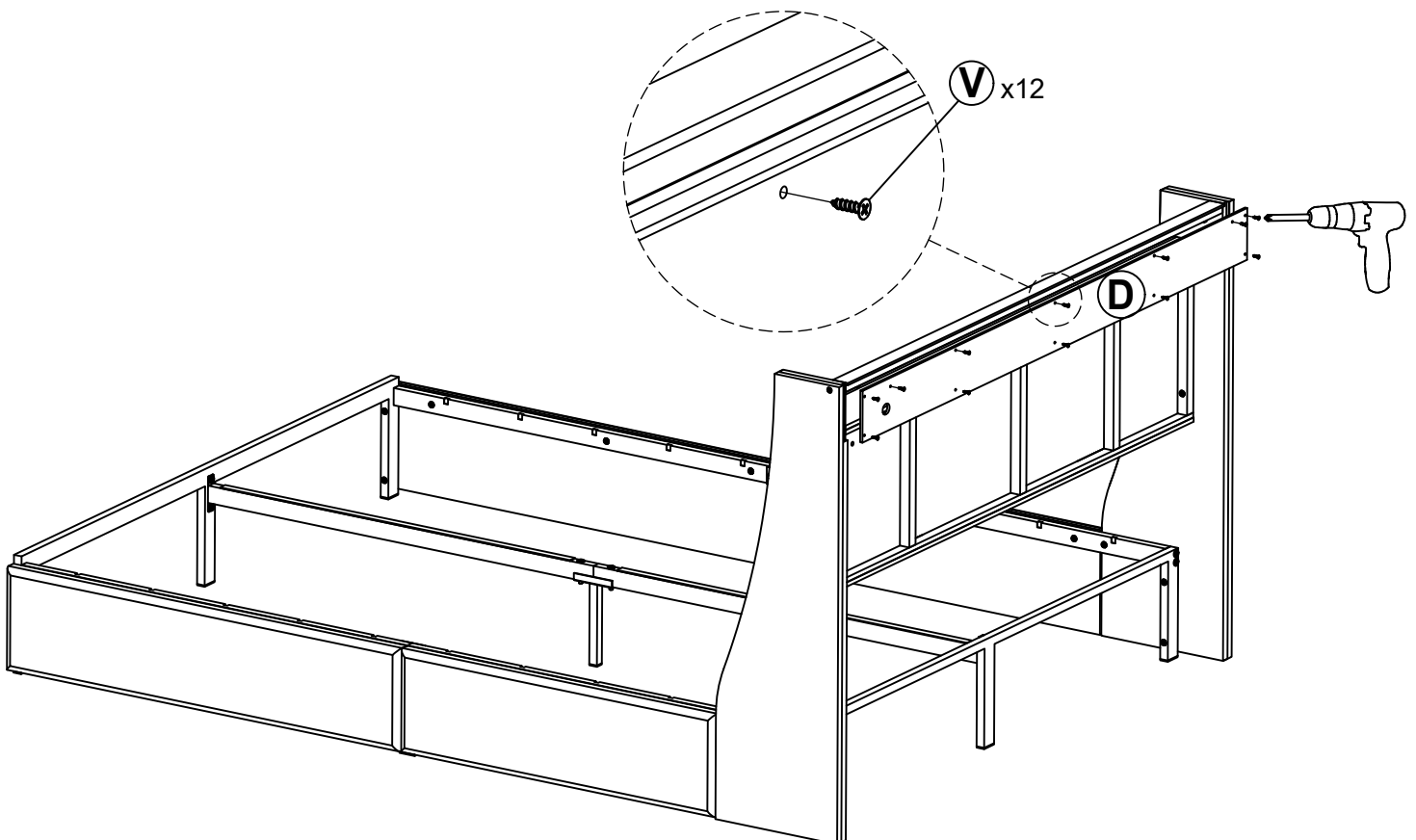

Step 5

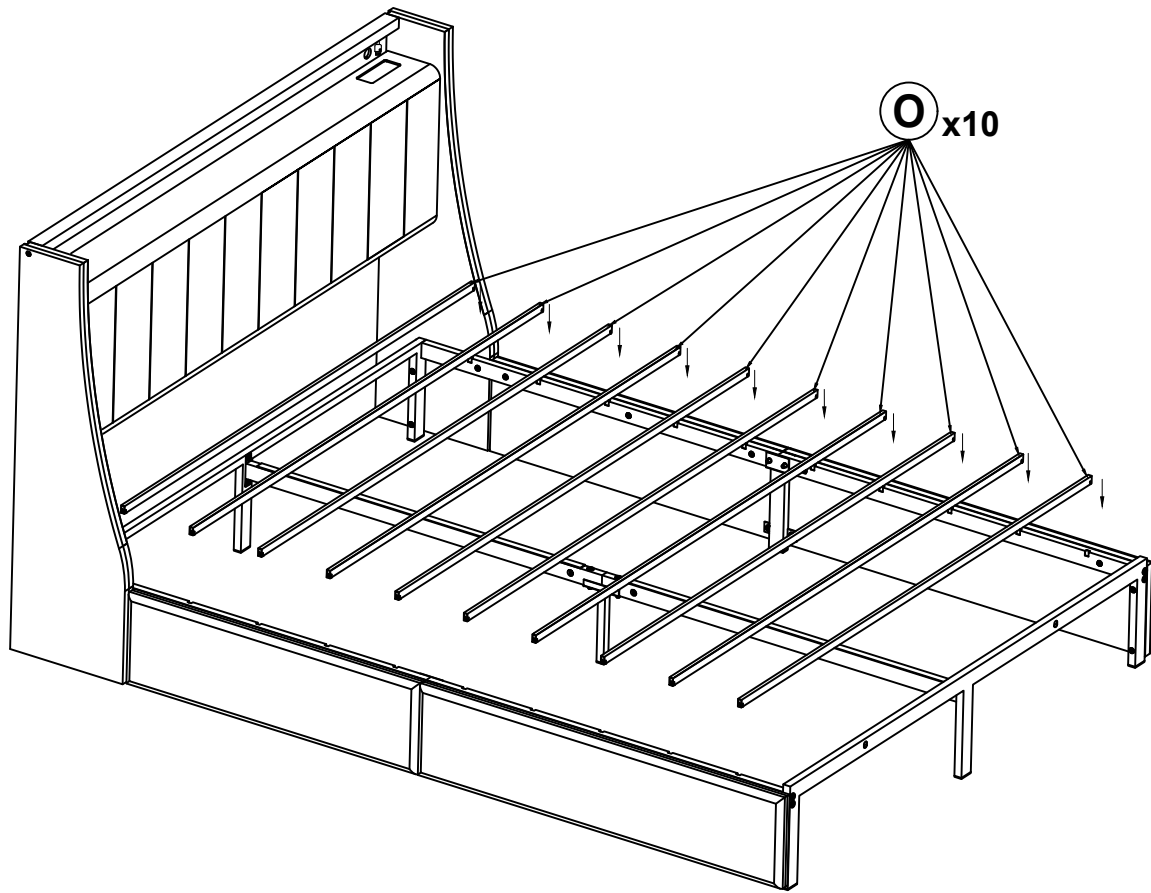

Step 6

Wheel mounting position

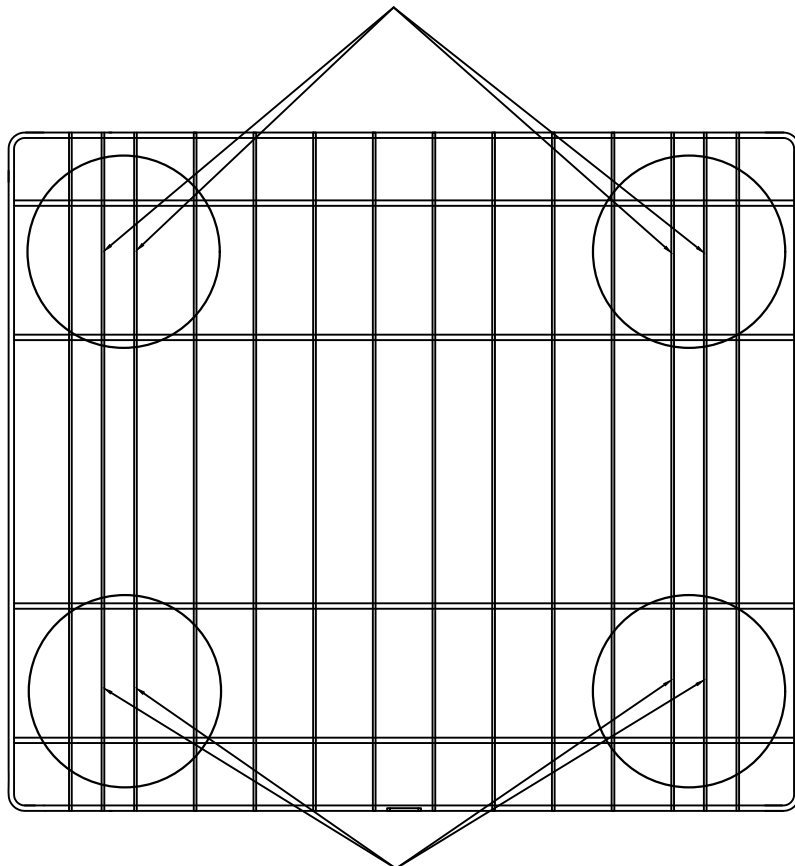

Wheel mounting position

Z5

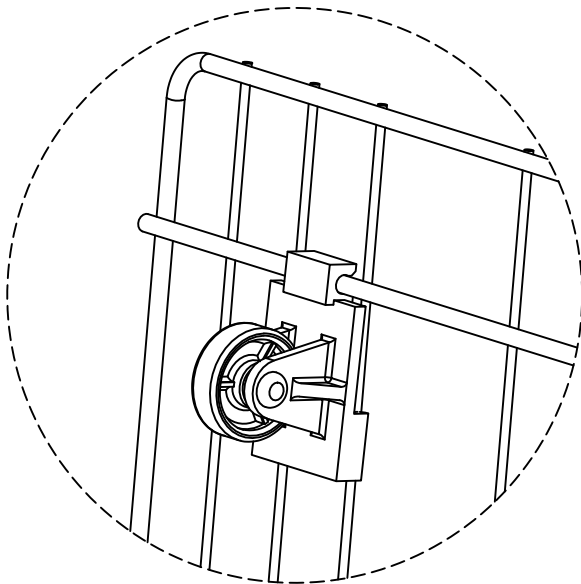
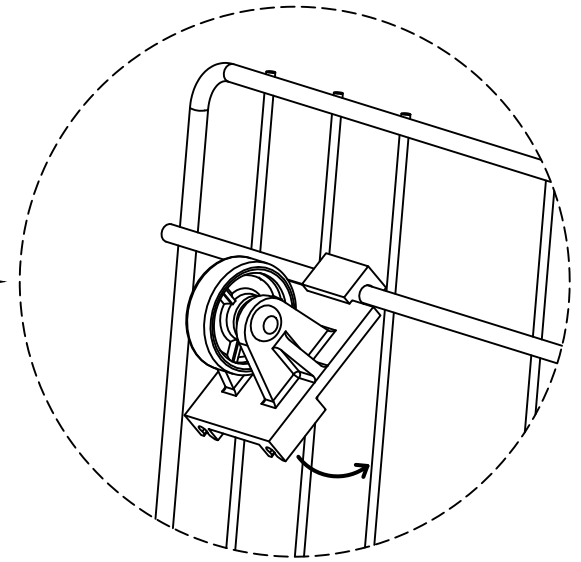
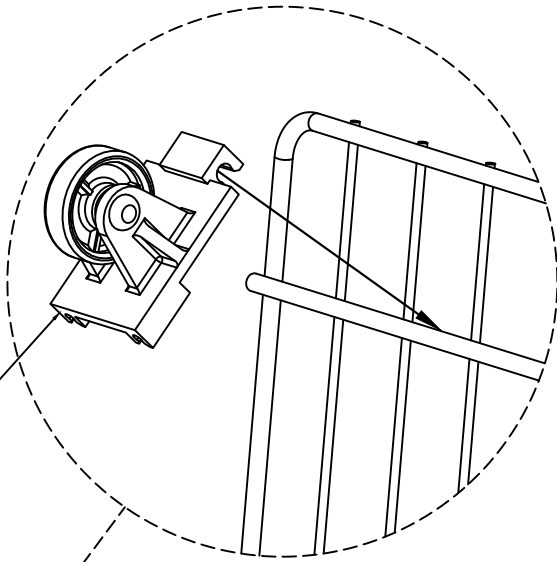

Z4

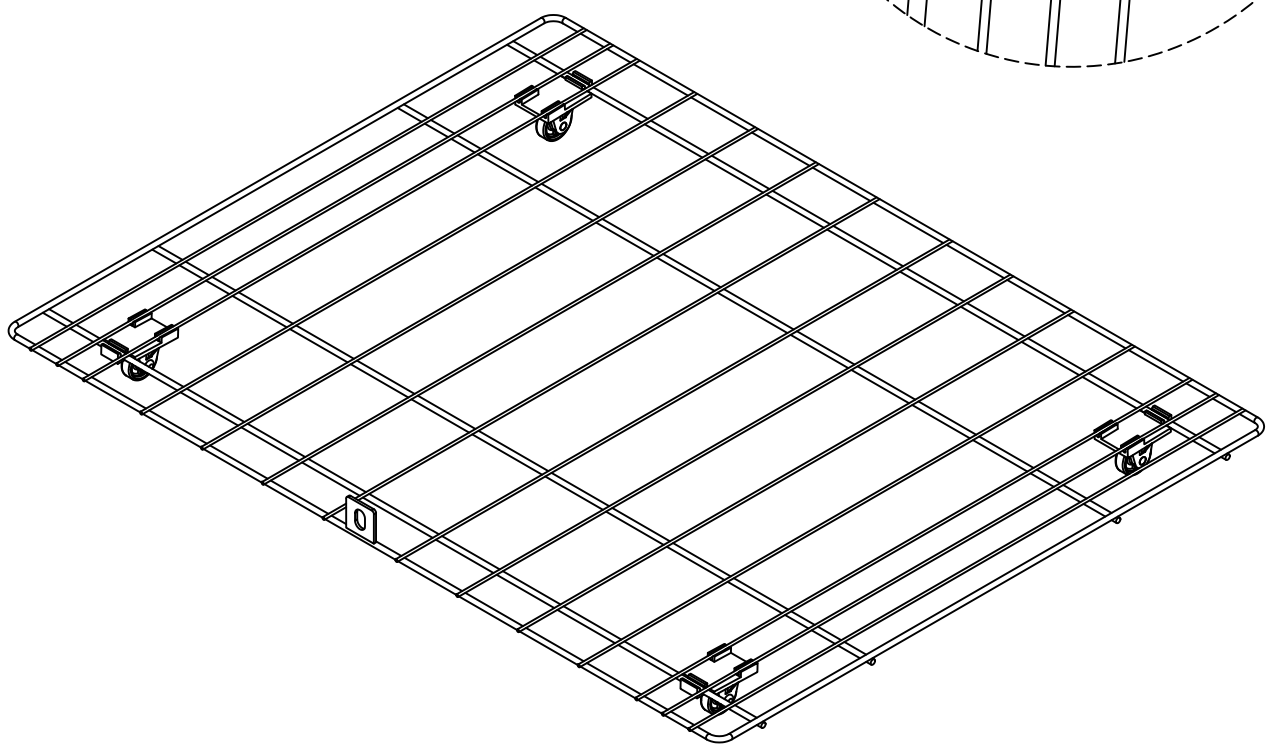
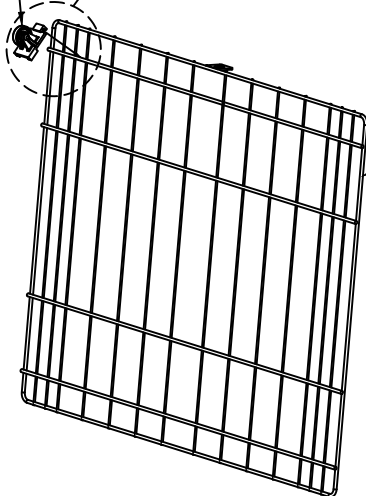

Detailed assembly instructions Q1

these two
lines on Q1.1
and Q1.2 need
to be matched

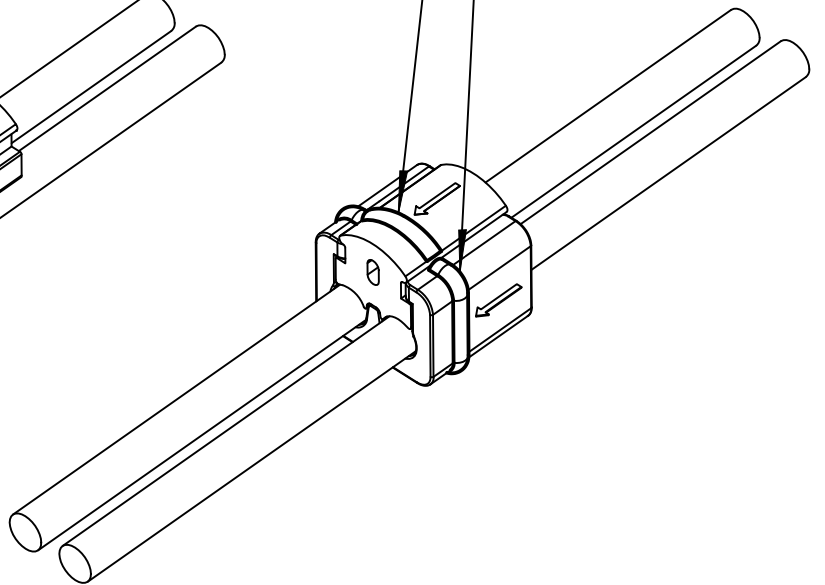
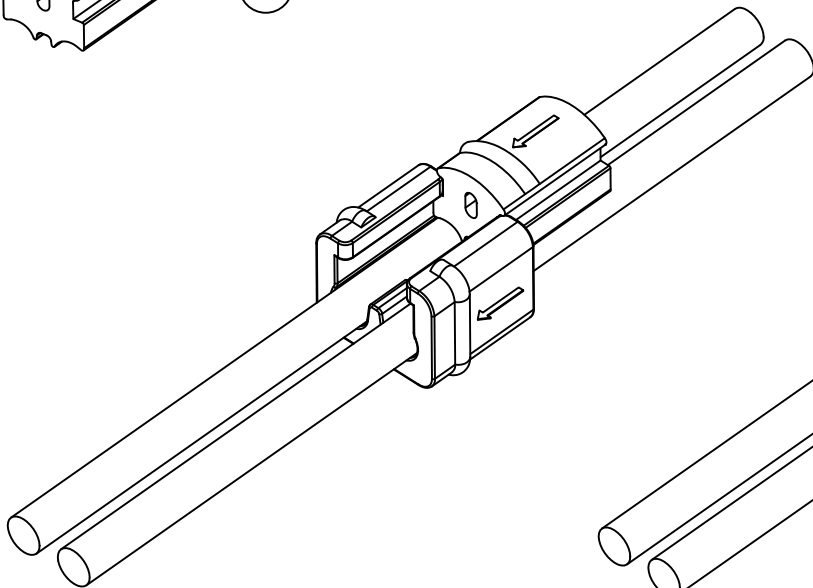
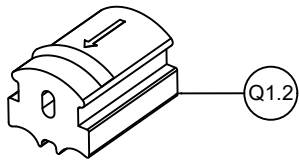
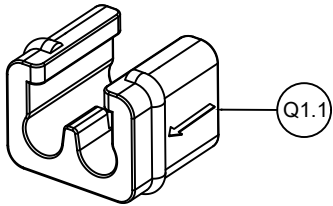

7.1

Step 7

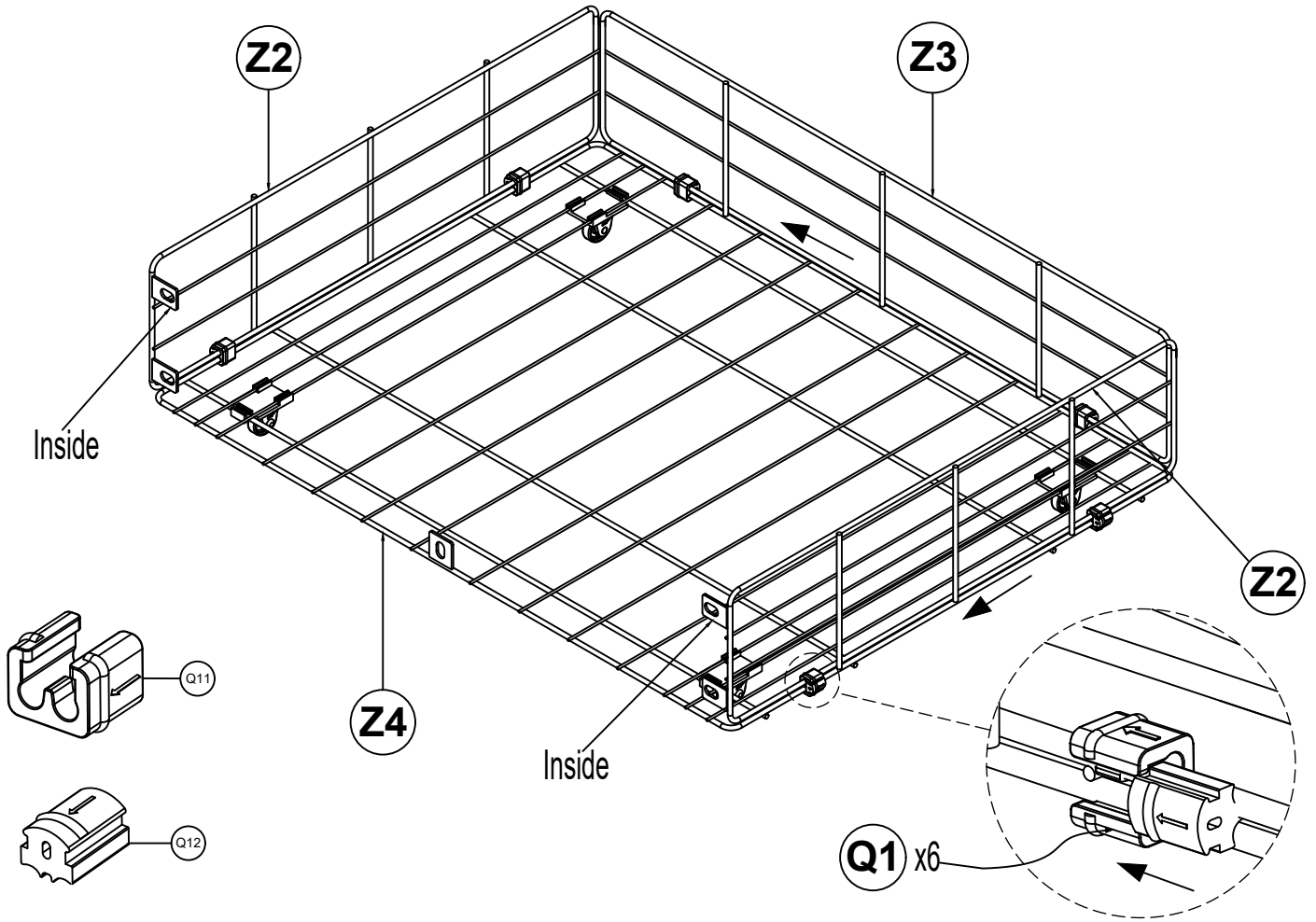

7.2

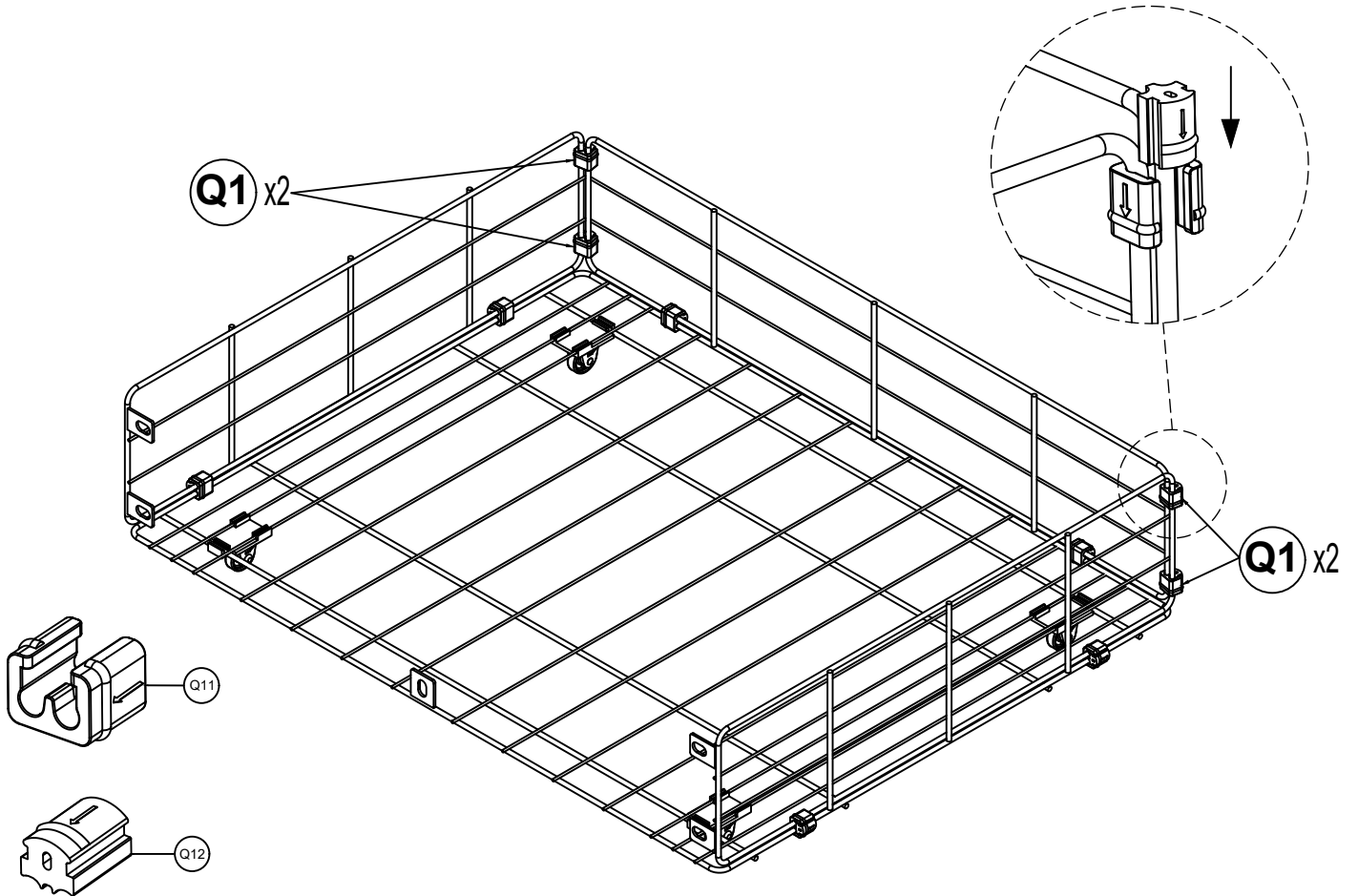

8.1

Step 8

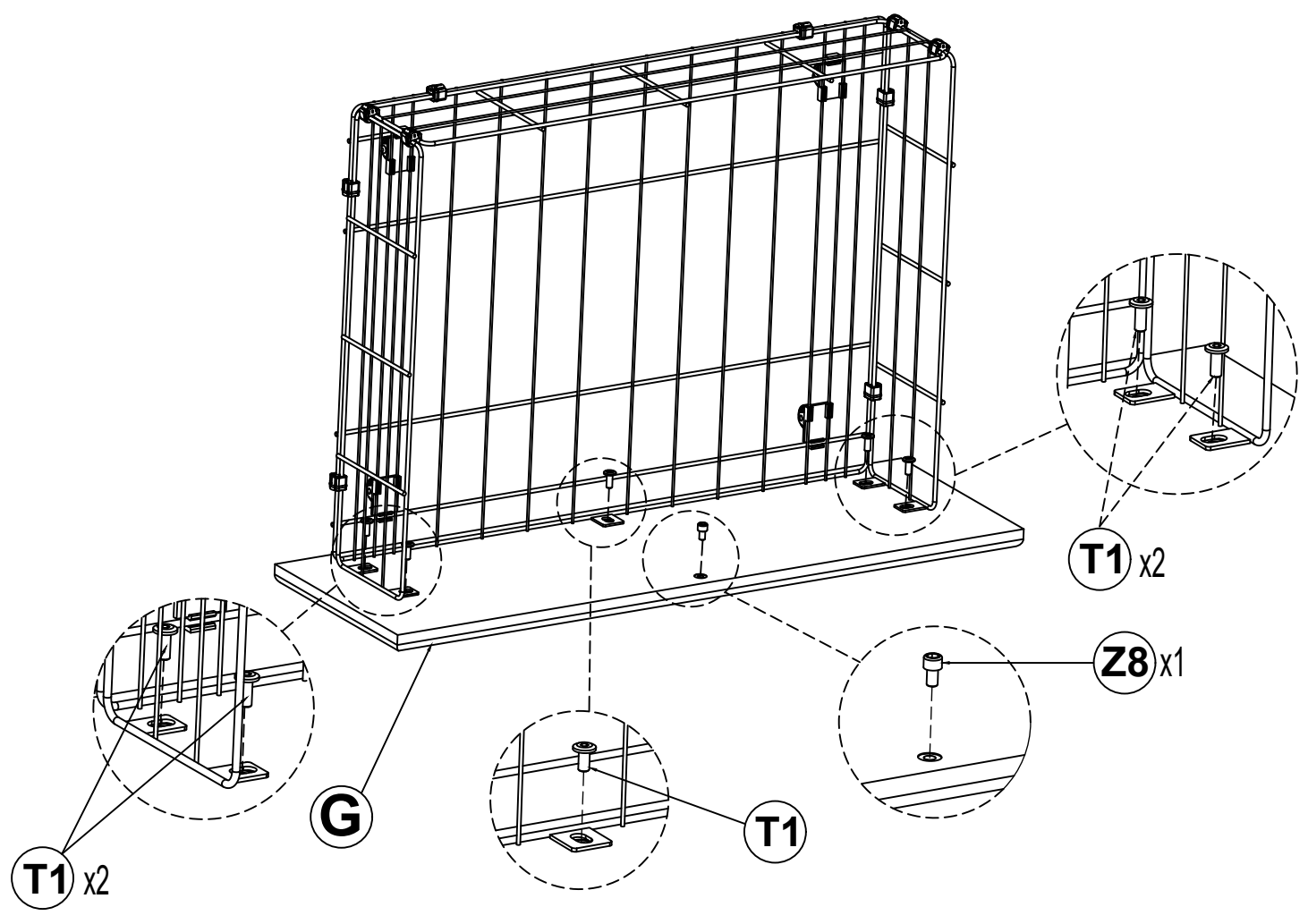

8.2

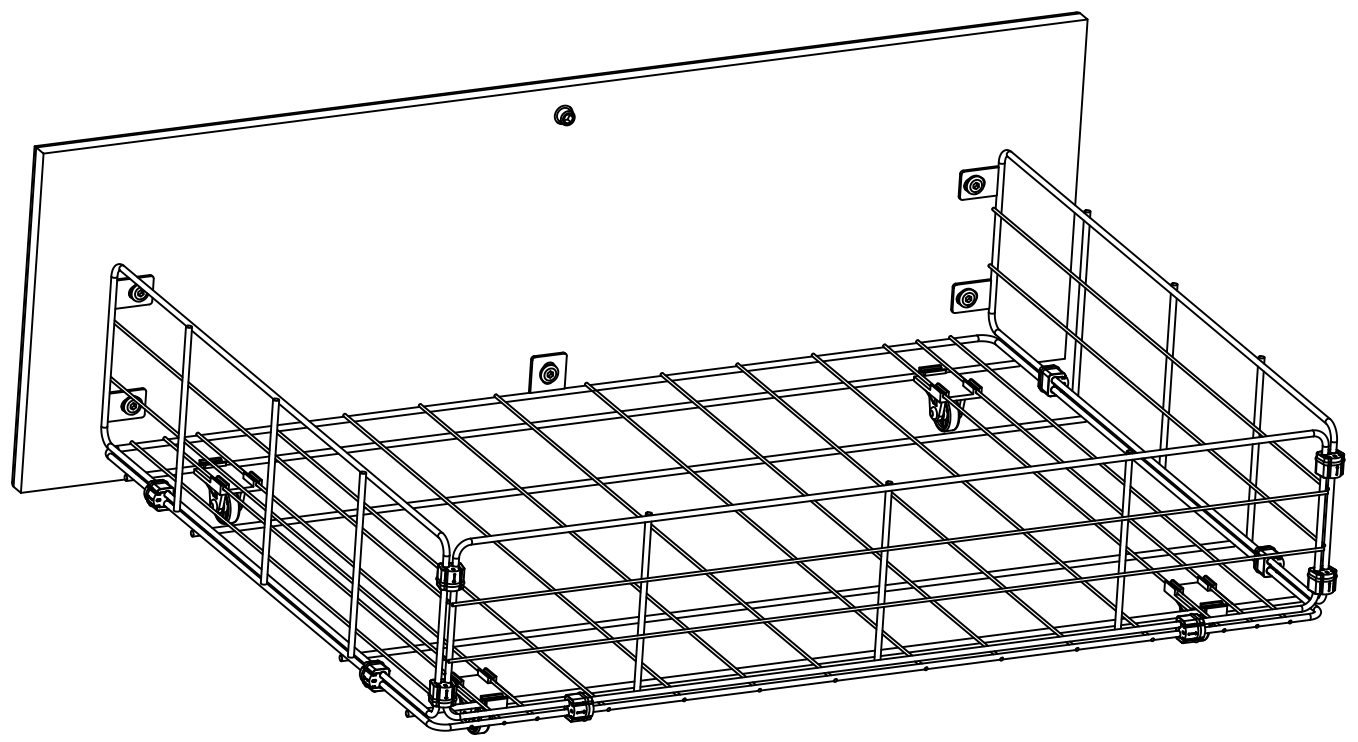

Step 9

2pcs

G

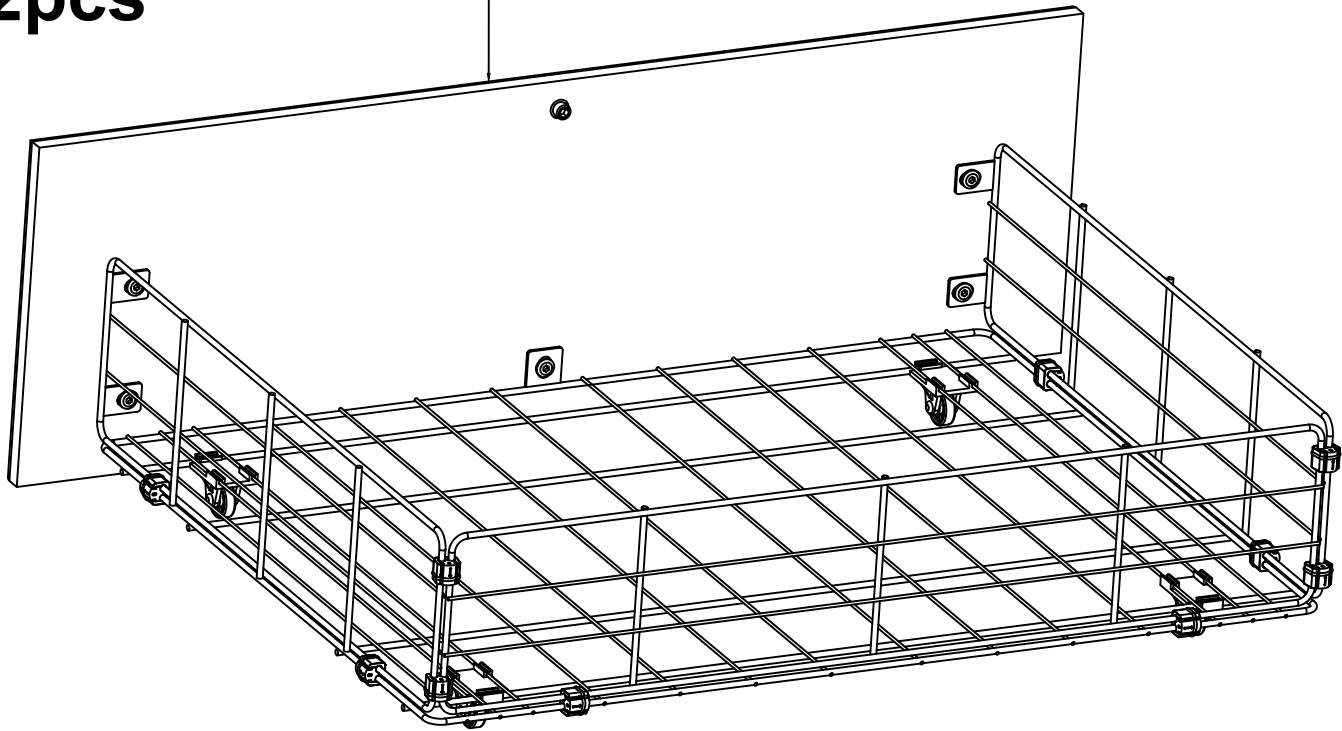

We suggest using drill machine to install "V" screw

