

# INSTALLATIONSANWEISUNG

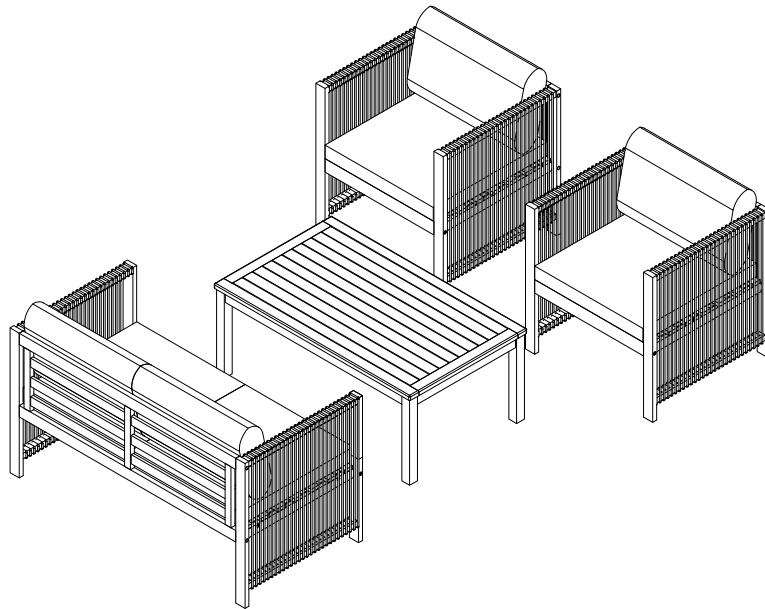

## EN Customer Service

Please read the instructions fully before assembly. These instructions include important information which could ensure correct assembly. We have been working on providing high quality products for

you. However, in the rare instance that your product is defective, missing parts or there are some issues, please don't hesitate to contact our customer service to submit parts requirements, assembly

suggestion, or warranty claims, and we will give the best solution as soon as possible. In order to solve the problem as quickly as possible, please provide the part number, quantity, and clearer picture of the defective part.

### Installation Tips

1. Tighten all screws to 50% before fastening them.
2. Place the item on a flat surface to adjust it and ensure it remains stable.
3. Gradually tighten all screws with a tool.
4. If screws become loose during assembly, please loosen all other screws by 50% and continue the assembly process.
5. If the item is not stable, please loosen all screws, align on a flat surface, and tighten all screws again.
6. If one or more screws are misaligned during assembly, there is a possibility that the others are not aligned with the holes. Additionally, all holes are designed to be relatively larger to provide more room for adjusting the screws.

## **DE Kundenservice**

Bitte lesen Sie die Anweisungen vollständig, bevor Sie mit der Montage beginnen. Diese Anweisungen enthalten wichtige Informationen, die eine korrekte Montage gewährleisten können. Wir arbeiten daran, qualitativ hochwertige Produkte für Sie bereitzustellen. Sollte Ihr Produkt jedoch im seltenen Fall defekt sein, Teile fehlen oder es Probleme gibt, zögern Sie bitte nicht, sich mit unserem Kundenservice in Verbindung zu setzen, um Teileanforderungen, Montagevorschläge oder Garantieansprüche zu übermitteln. Wir werden so schnell wie möglich die beste Lösung bieten. Um das Problem so schnell wie möglich zu lösen, geben Sie bitte die Teilenummer, Menge und ein klareres Bild des defekten Teils an.

### Installationshinweise

1. Ziehen Sie alle Schrauben zu 50 % fest, bevor Sie sie befestigen.
2. Stellen Sie den Artikel auf eine ebene Fläche, um ihn einzustellen und sicherzustellen, dass er stabil bleibt.
3. Ziehen Sie alle Schrauben allmählich mit einem Werkzeug fest.
4. Wenn Schrauben während der Montage locker werden, lockern Sie bitte alle anderen Schrauben um 50 % und setzen Sie den Montageprozess fort
5. Wenn der Artikel nicht stabil ist, lockern Sie bitte alle Schrauben, richten Sie ihn auf einer ebenen Fläche aus und ziehen Sie alle Schrauben erneut fest.
6. Wenn bei der Montage eine oder mehrere Schrauben nicht ausgerichtet sind, besteht die Möglichkeit, dass die anderen nicht mit den Löchern ausgerichtet sind. Außerdem sind alle Löcher so konzipiert, dass sie relativ größer sind, um mehr Platz für die Einstellung der Schrauben zu bieten.

## **FR Service Client**

Veuillez lire attentivement les instructions avant l'assemblage. Ces instructions contiennent des informations importantes qui peuvent garantir un montage correct. Nous travaillons à fournir des produits de haute qualité pour vous. Cependant, dans le cas rare où votre produit est défectueux, des pièces sont manquantes ou s'il y a des problèmes, n'hésitez pas à contacter notre service client pour soumettre des demandes de pièces, des suggestions d'assemblage ou des réclamations de garantie, et nous vous fournirons la meilleure solution dès que possible. Afin de résoudre le problème le plus rapidement possible, veuillez fournir le numéro de pièce, la quantité et une photo plus claire de la pièce défectueuse.







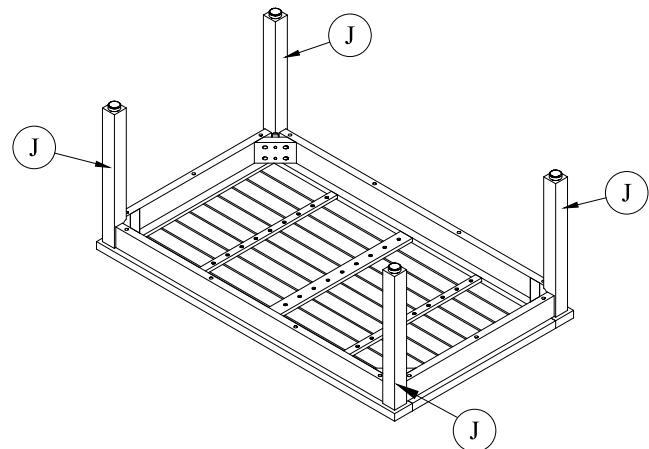
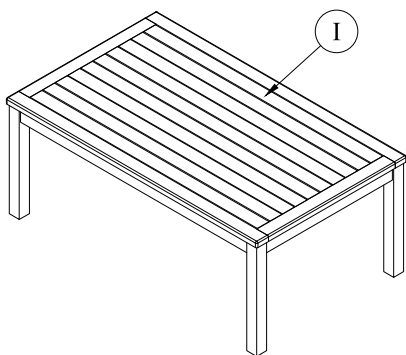
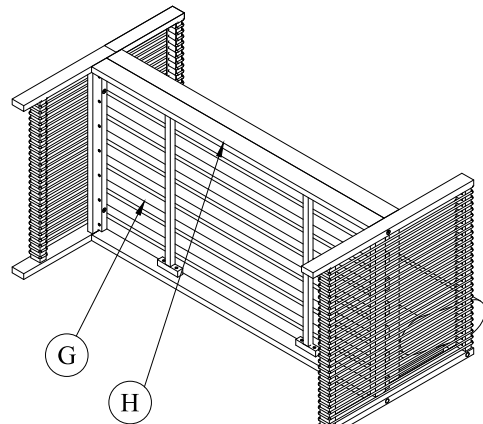
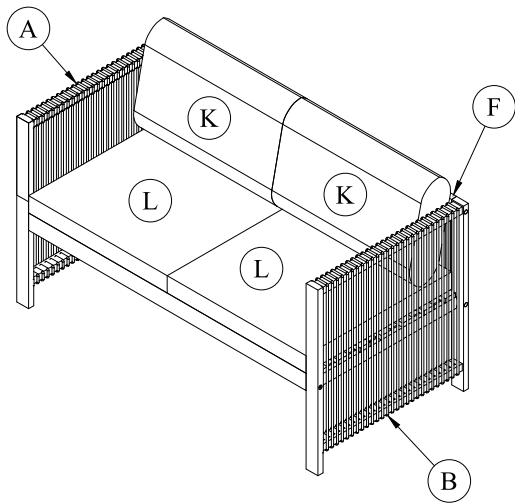
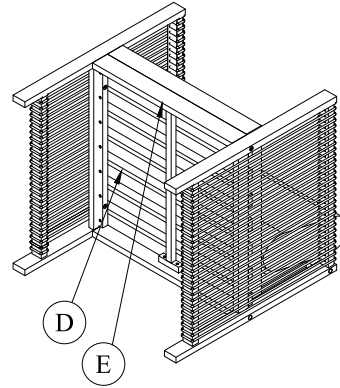
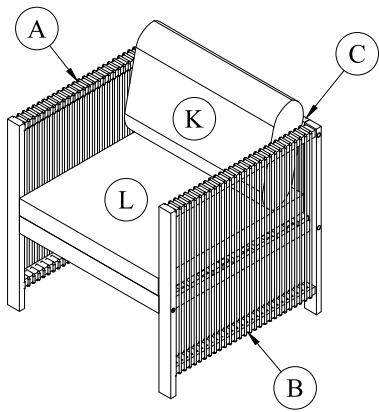

### Conseils d'Installation

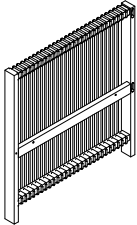
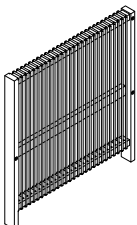
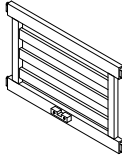
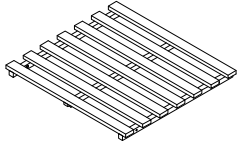
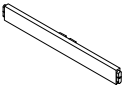
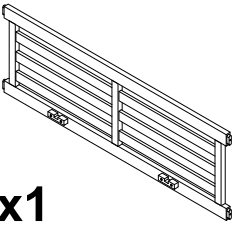
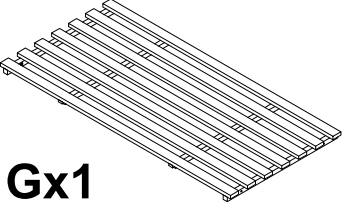
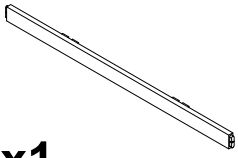
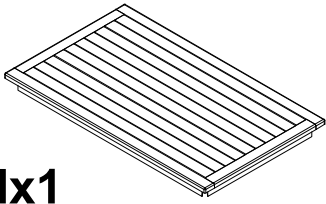
1. Serrez toutes les vis à 50 % avant de les fixer.
2. lacez l'article sur une surface plane pour l'ajuster et assurez-vous qu'il reste stable.
3. Serrez progressivement toutes les vis avec un outil.
4. Si les vis se desserrent pendant l'assemblage, veuillez desserrer toutes les autres vis de 50 % et continuer le processus d'assemblage.
5. Si l'article n'est pas stable, veuillez desserrer toutes les vis, aligner sur une surface plane et resserrer toutes les vis à nouveau.
6. Si une ou plusieurs vis sont mal alignées pendant l'assemblage, il est possible que les autres ne soient pas alignées avec les trous. De plus, tous les trous sont conçus pour être relativement plus grands afin de fournir plus d'espace pour ajuster les vis.

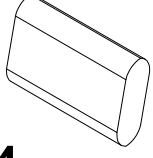
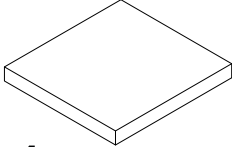
# Explodierte Ansicht

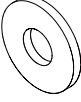

# Teileliste & Hardwareliste

 <p><b>Ax3</b></p>	 <p><b>Bx3</b></p>	 <p><b>Cx2</b></p>	 <p><b>Dx2</b></p>
 <p><b>Ex2</b></p>	 <p><b>Fx1</b></p>	 <p><b>Gx1</b></p>	 <p><b>Hx1</b></p>
 <p><b>Ix1</b></p>	 <p><b>Jx4</b></p>	 <p><b>Kx4</b></p>	 <p><b>Lx4</b></p>
 <p><b>1- Screw 6x90 : 18</b></p>	 <p><b>2- Screw 6x35 : 12</b></p>	 <p><b>3- Nuts 8x13 : 8</b></p>	 <p><b>4- Washer 8x20: 8</b></p>
 <p><b>5- Allen key: 2</b></p>	 <p><b>6- Wrench 13: 1</b></p>		
			<p><b>Seite 4</b></p>

# KARTONINHALT

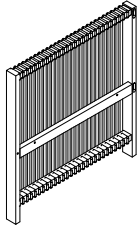

**Ax2**

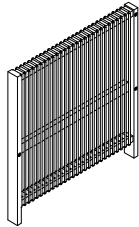

**Bx2**

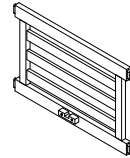

**Cx2**

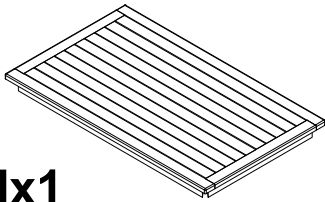

**Ix1**

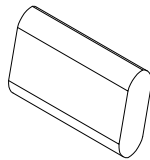

**Kx4**

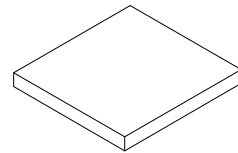

**Lx2**

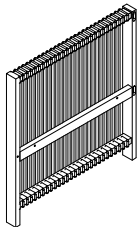

**Ax1**

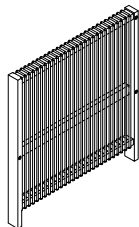

**Bx1**

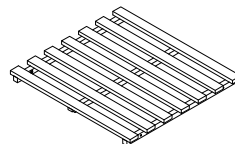

**Dx2**

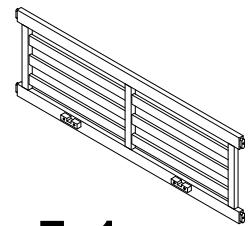

**Fx1**

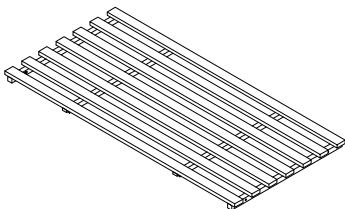

**Gx1**

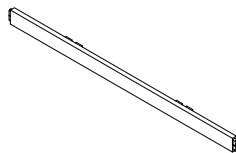

**Hx1**

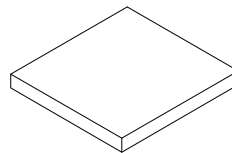

**Lx2**

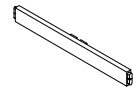

**Ex2**



**Jx4**



**Hw**

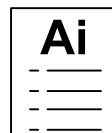

**Ai**

# SCHRITT 1

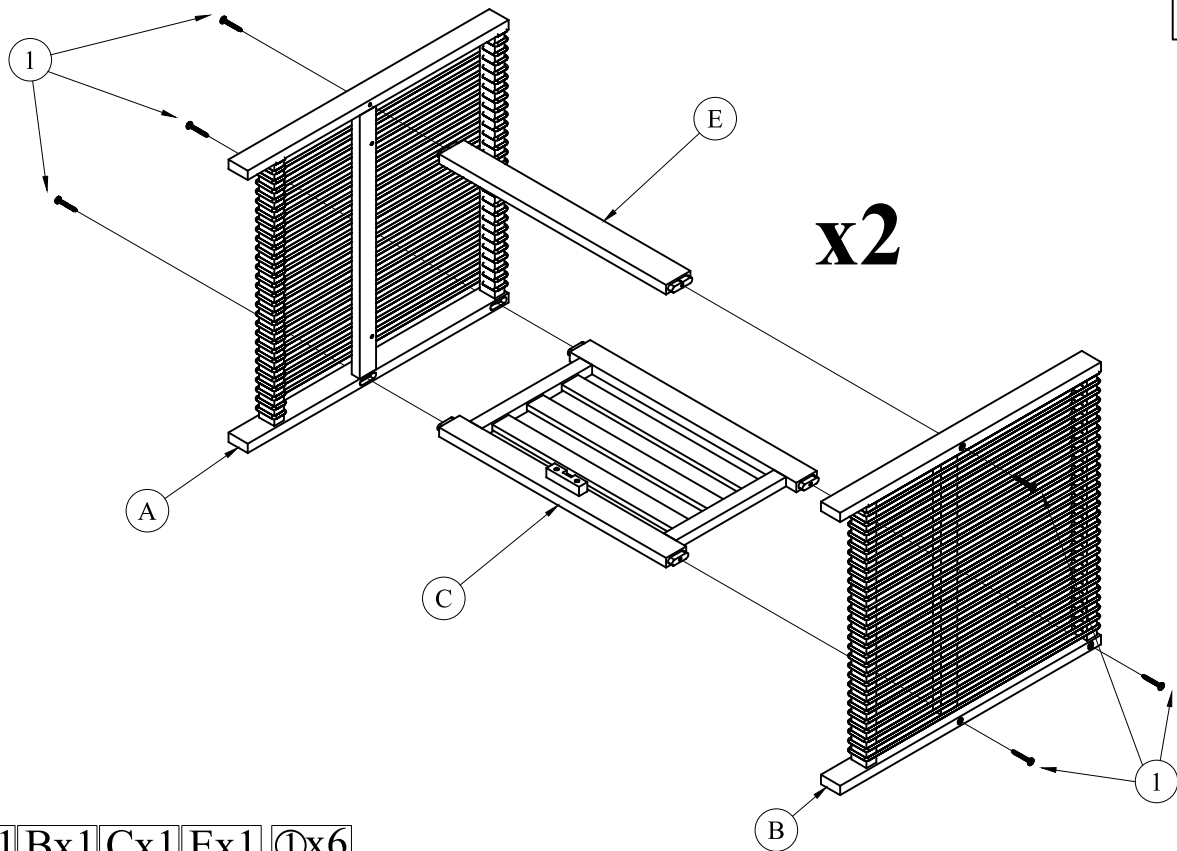

Ax1 Bx1 Cx1 Ex1 Ⓢx6

# SCHRITT 2

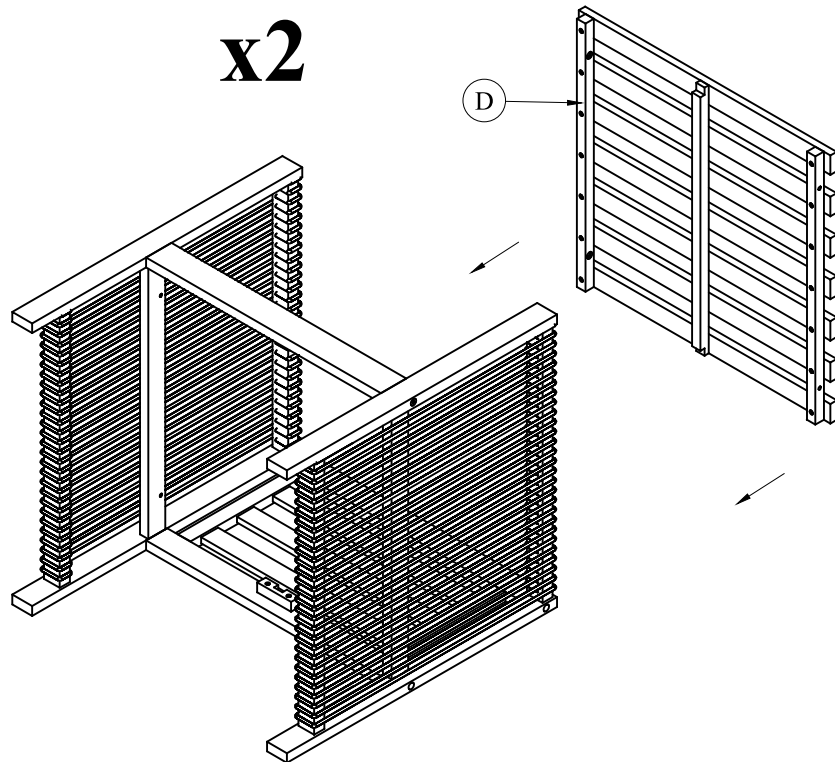

Dx1

# SCHRITT 3

x2

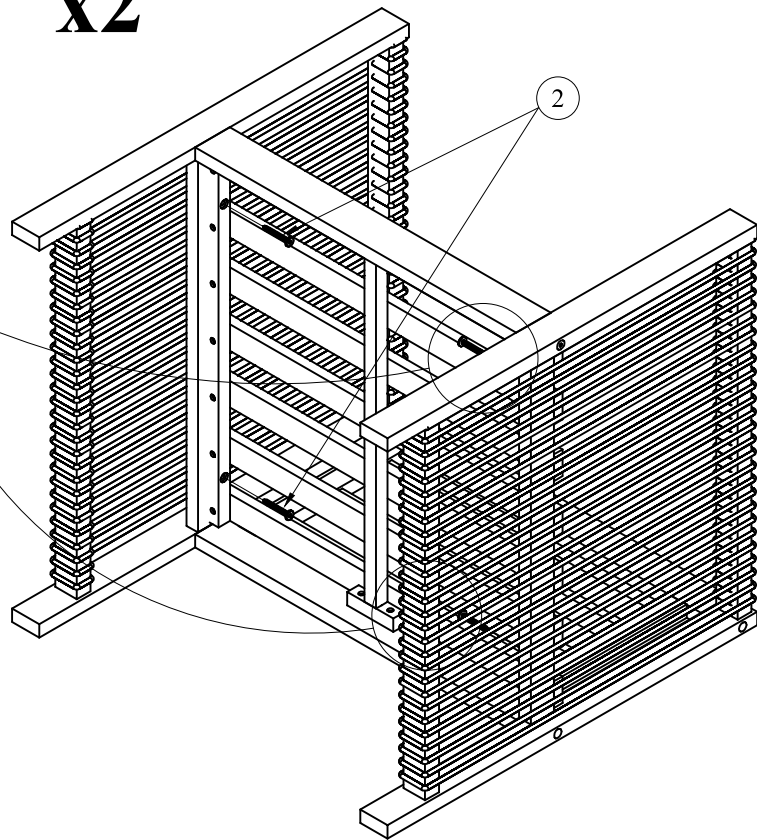
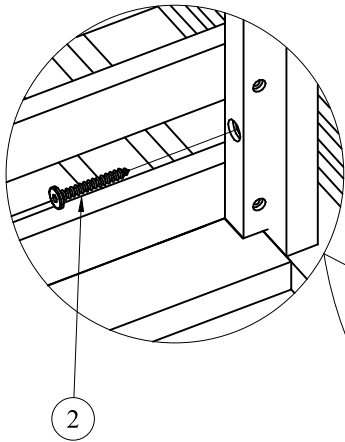

2x4

# SCHRITT 4

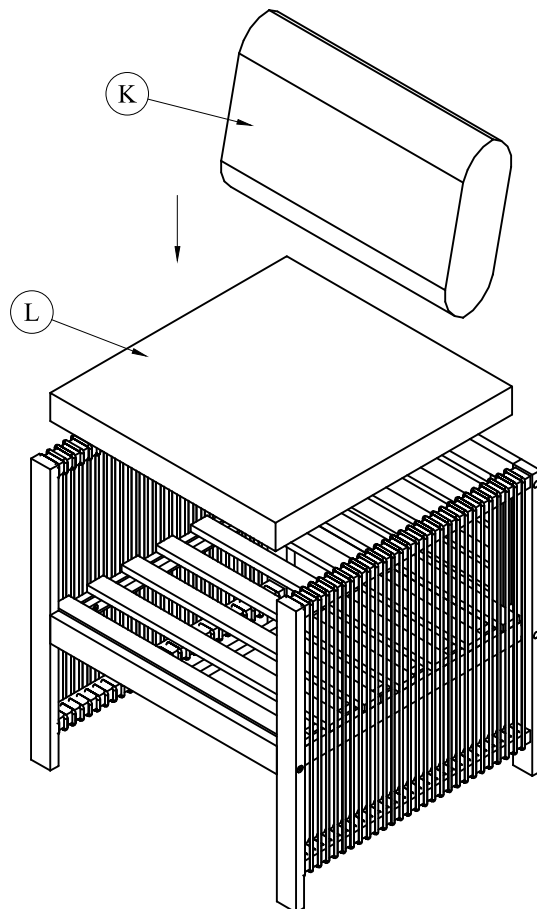

x2

Kx1 Lx1

# SCHRITT 5

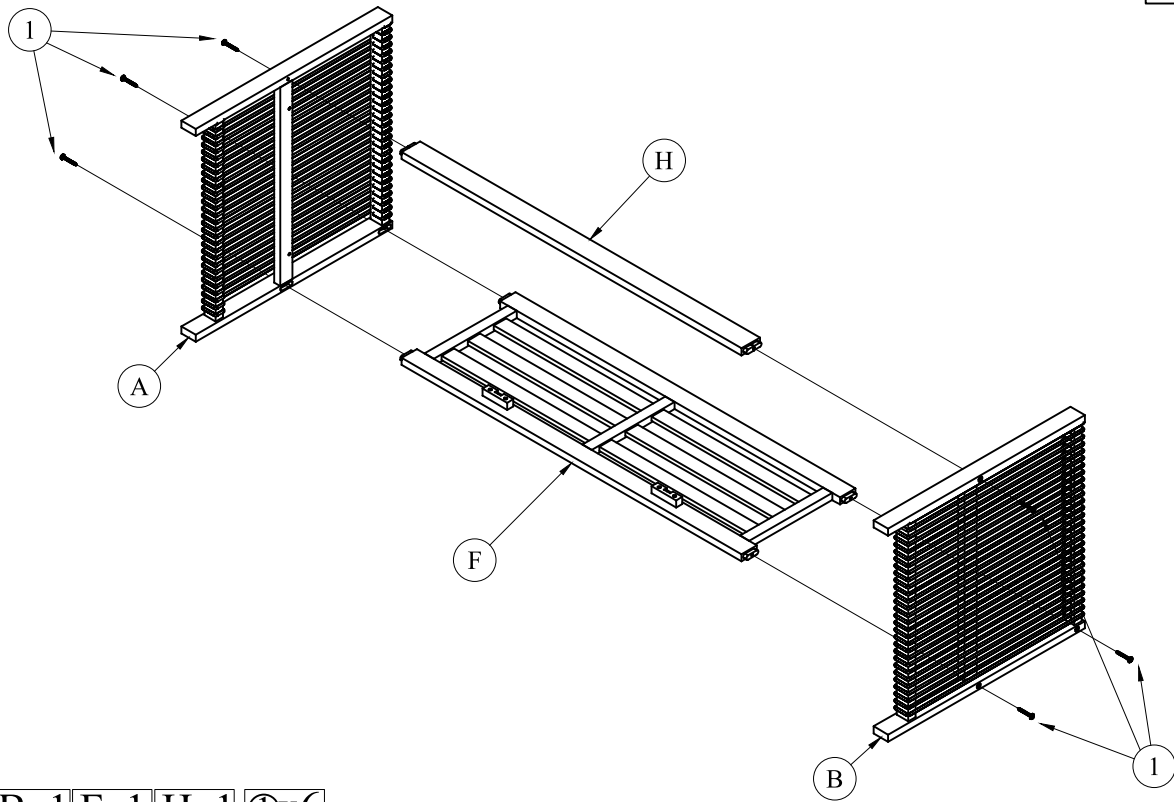
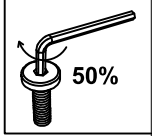

Ax1 Bx1 Fx1 Hx1 Ⓛx6

# SCHRITT 6

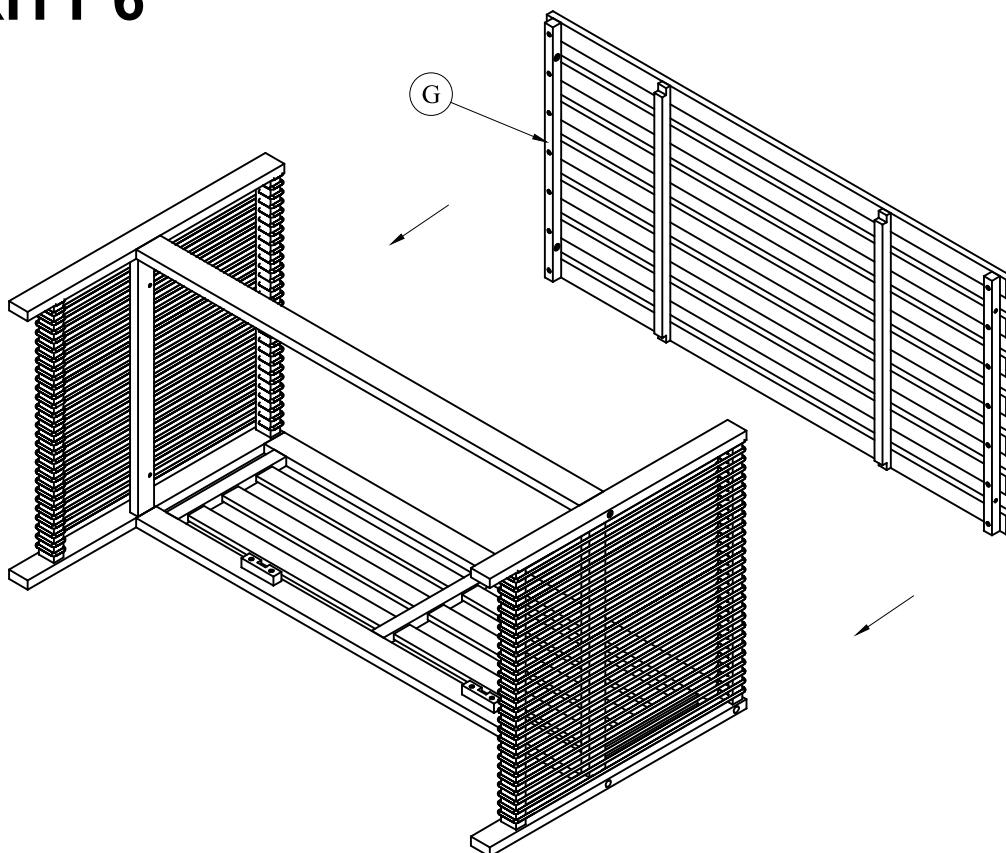

Gx1

# SCHRITT 7

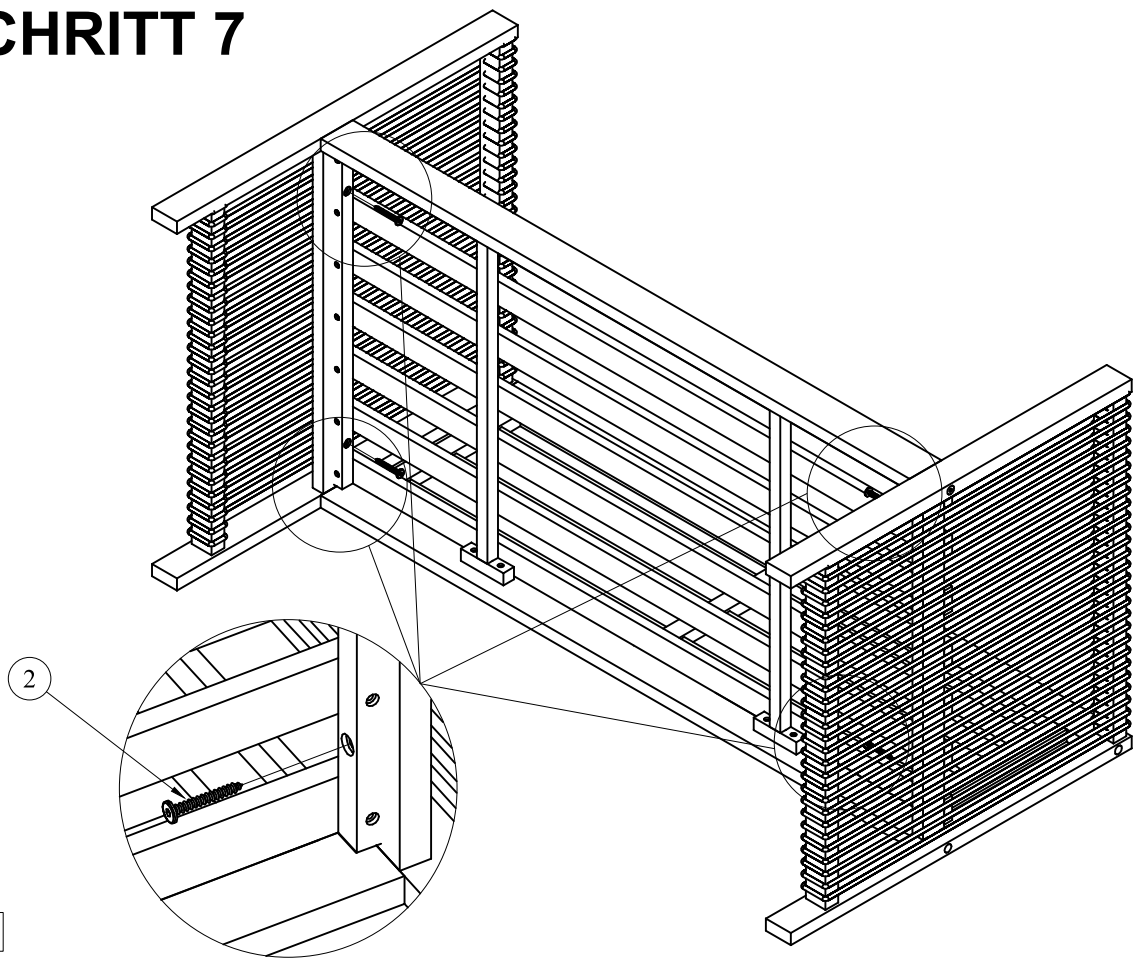
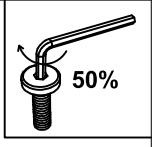

2x4

# SCHRITT 8

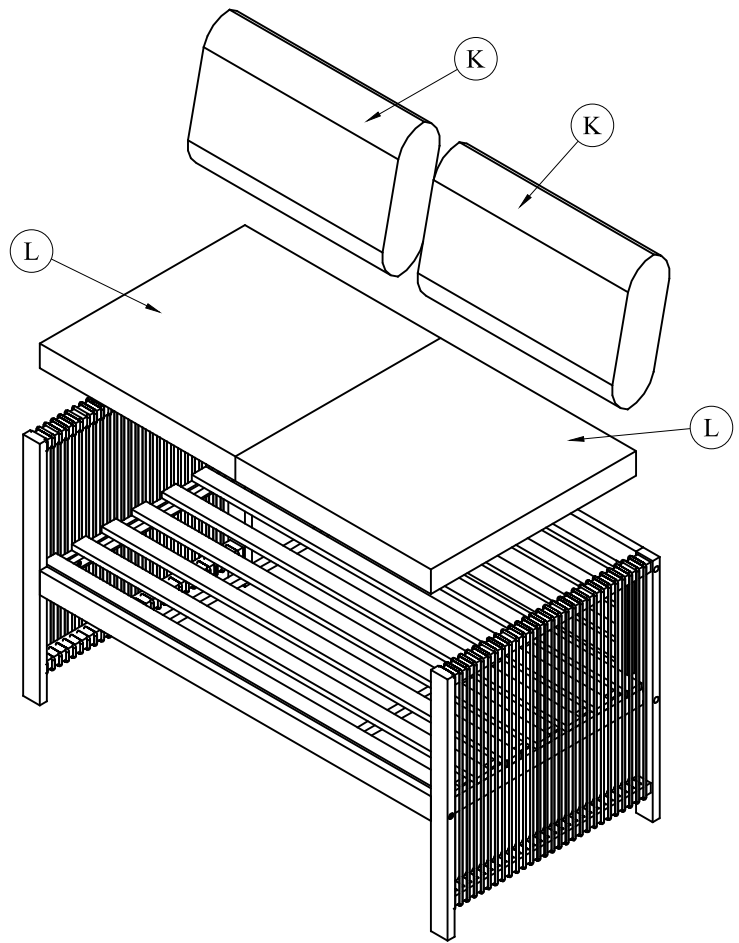
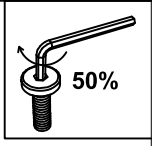

Kx2 Lx2

# SCHRITT 9

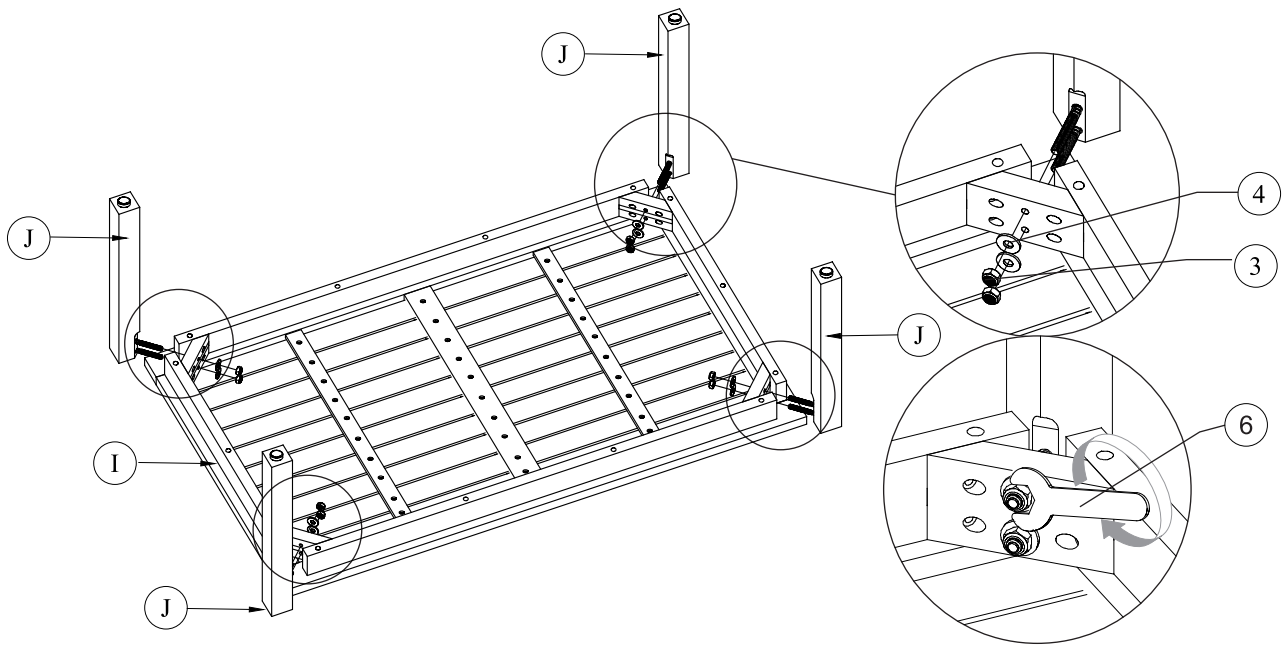
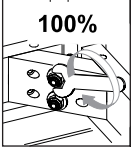

Ix1 Jx4 ③x8 ④x8

# SCHRITT 10

