

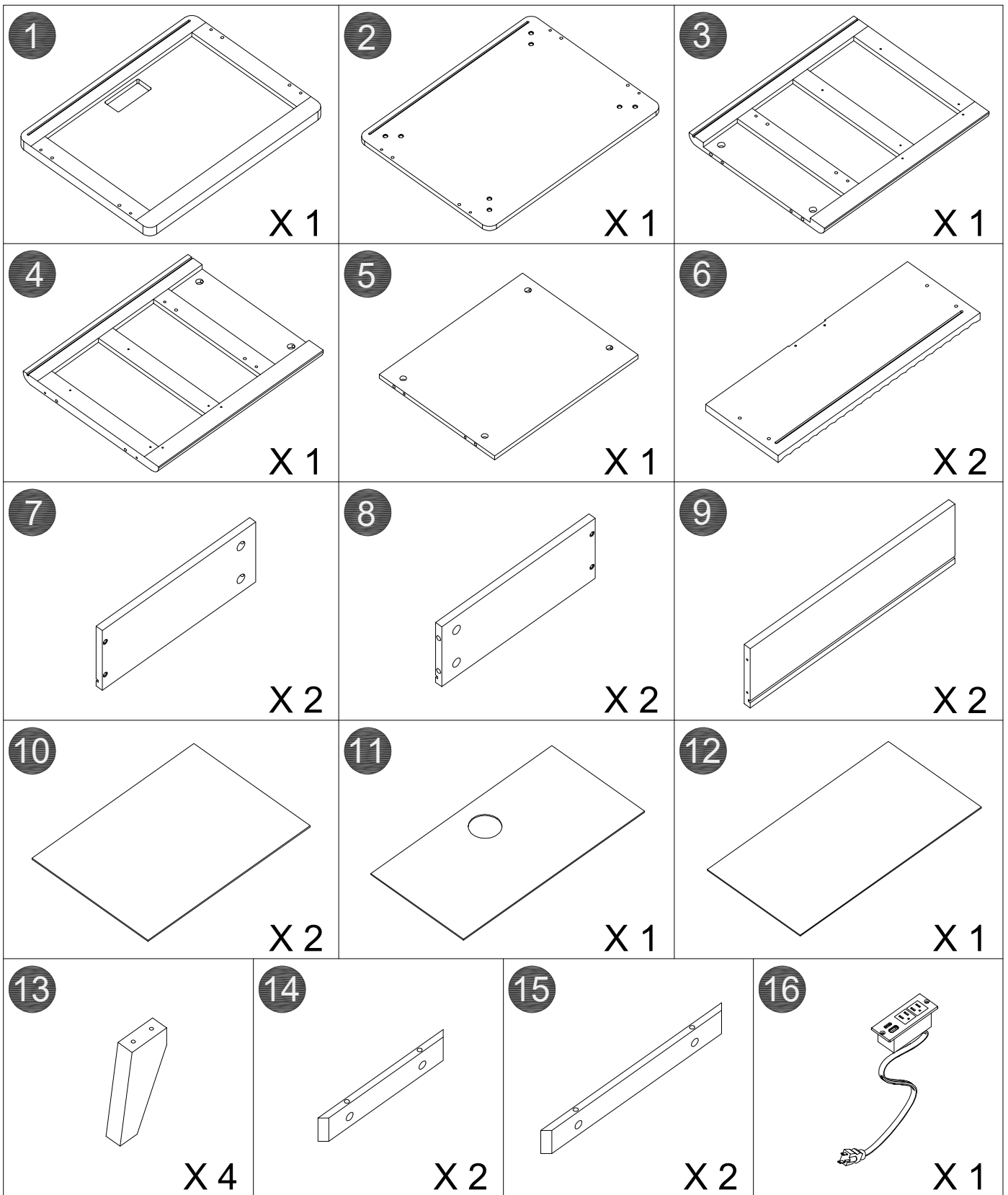

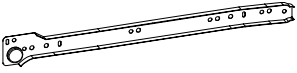

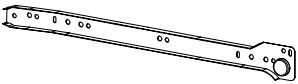
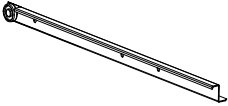
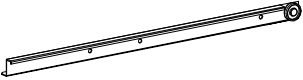
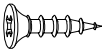
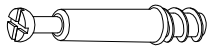

LHNS84

LHNS84 ASSEMBLY INSTRUCTION

THANKS for buying our products,read it carefully before installation(Attention:Don't tighten the screws before all screws are in place.). If the screws and holes don't match.Pls carefully check whether there is an error or loosen some associated screws to rectify.Thanks for your patience!

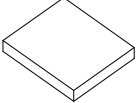
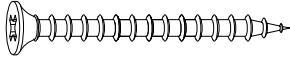
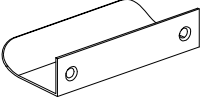
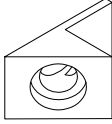

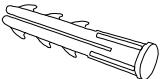
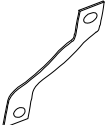
<p>A1 X 2</p> 	<p>A2 X 2</p> 	<p>B1 X 2</p> 
<p>B2 X 2</p> 	<p>C X 36</p>  <p>M3.5x12mm</p>	<p>D X24</p>  <p>M6x35mm</p>
<p>E X 24</p>  <p>Φ15mm</p>	<p>F X 12</p>  <p>Φ6x30mm</p>	<p>G X 8</p>  <p>M7x50mm</p>
<p>H X 4</p>  <p>M5x40mm</p>	<p>I X 4</p>  <p>EVA</p>	<p>J X10</p>  <p>M4x40mm</p>
<p>K X 2</p> 	<p>L X 8</p> 	<p>M X 1</p>  <p>4#</p>
<p>N X 20</p>  <p>Ø20mm</p>	<p>O X 2</p> 	<p>P X 2</p> 

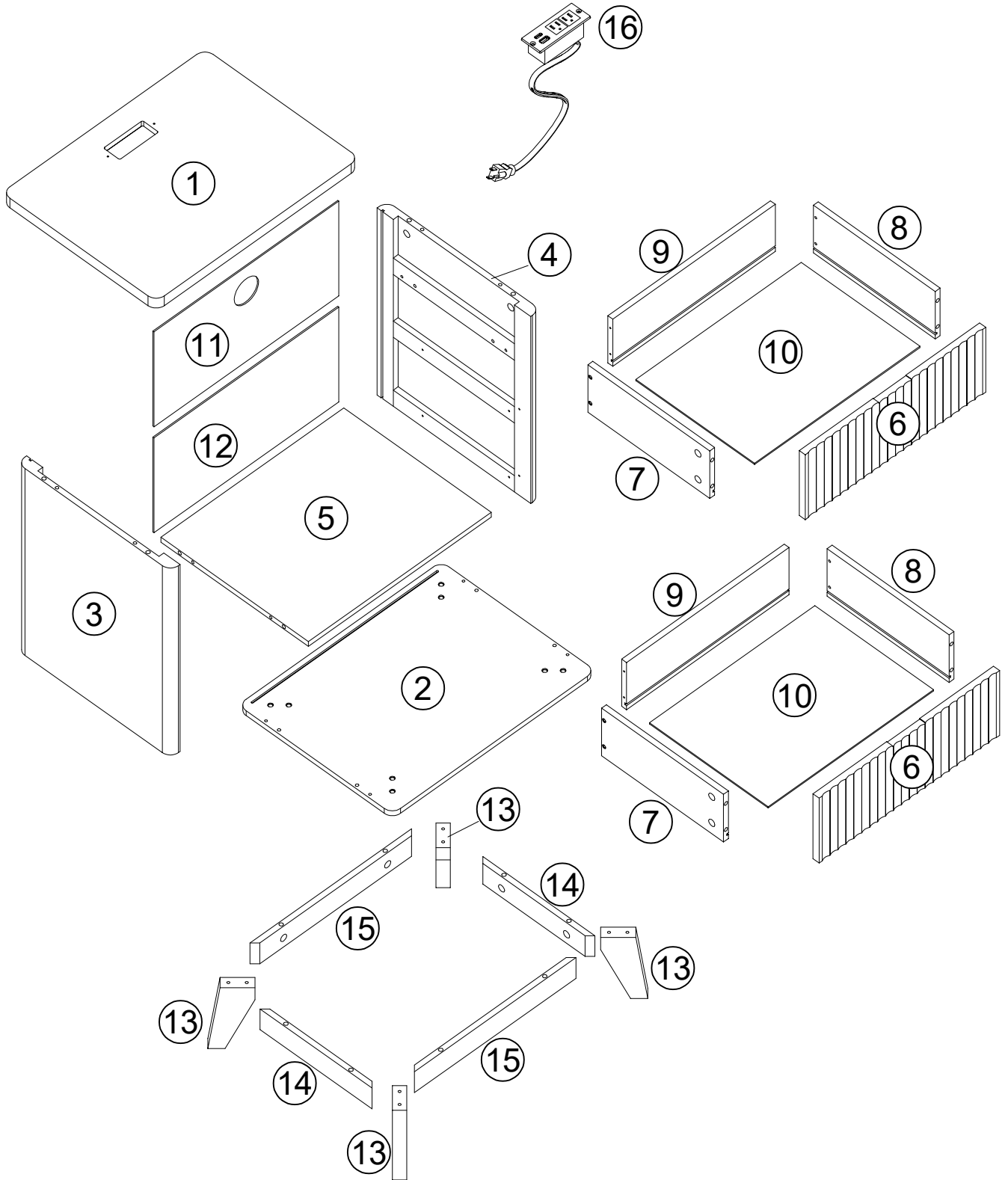

STEP 1

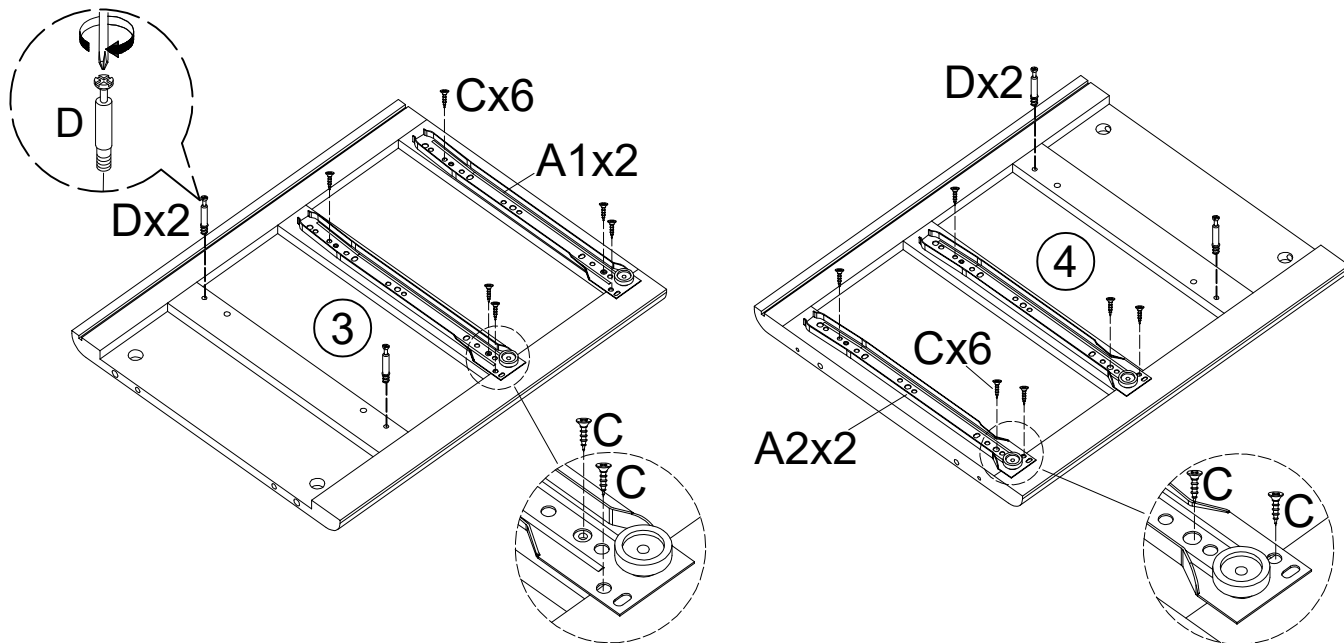

The holes on the 3&4 board are tun nail holes for adding stability.

A1	x2	A2	x2	D	x4	C	x12
				M6x35mm		M3.5x12mm	

STEP 2

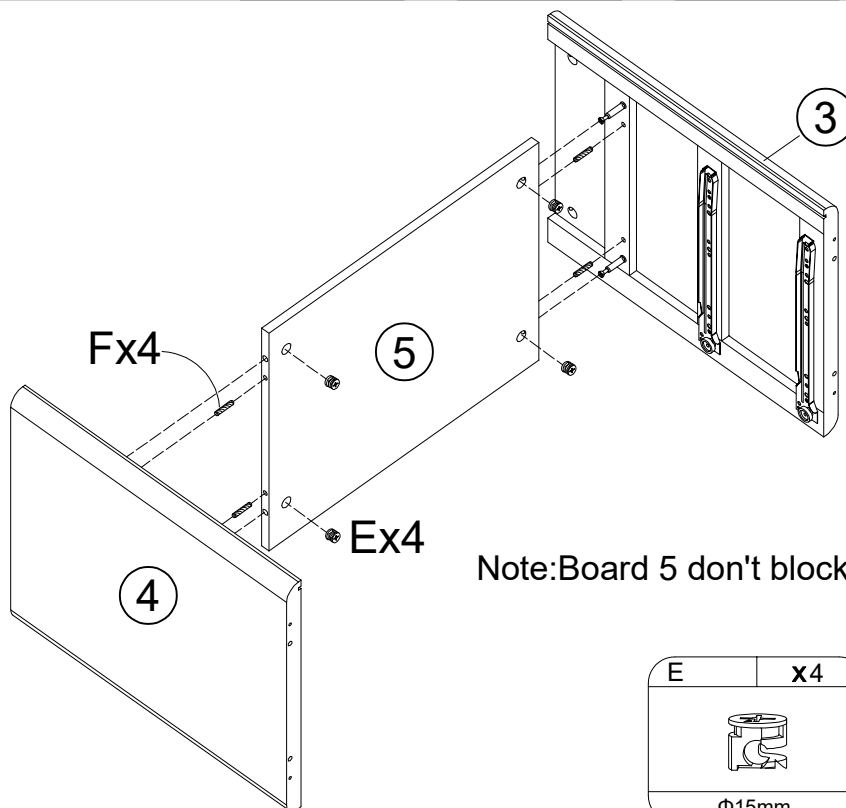

Note: Board 5 don't block the groove.

E	x4	F	x4
Φ15mm		Φ6x30mm	

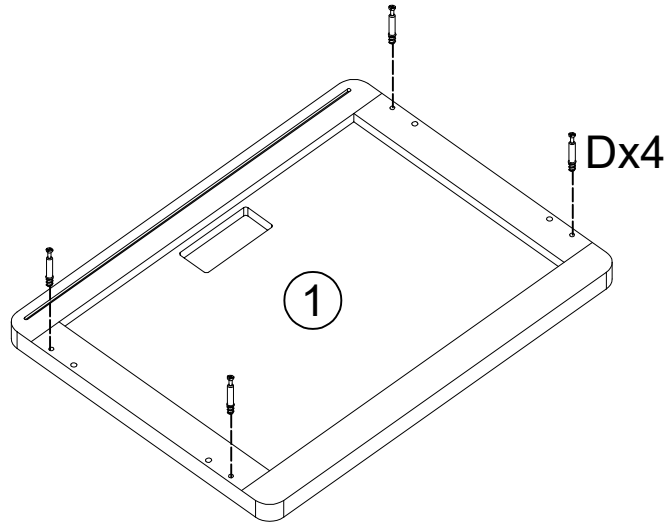

STEP 3

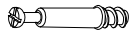

D	x4
	
M6x35mm	

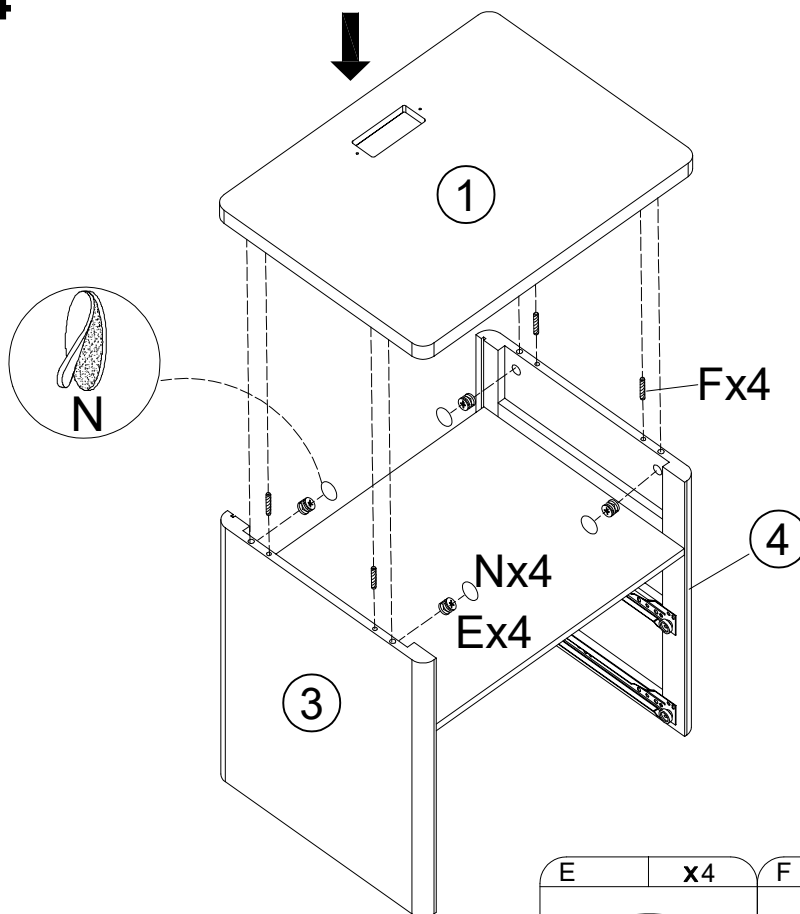
STEP 4

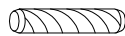

E	x4	F	x4	N	x4
					
Φ15mm		Φ6x30mm		Φ20mm	

STEP 5

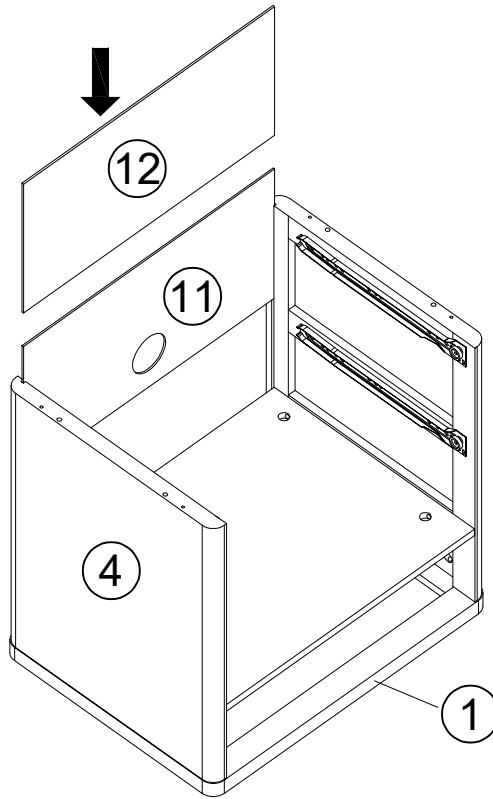

STEP 6

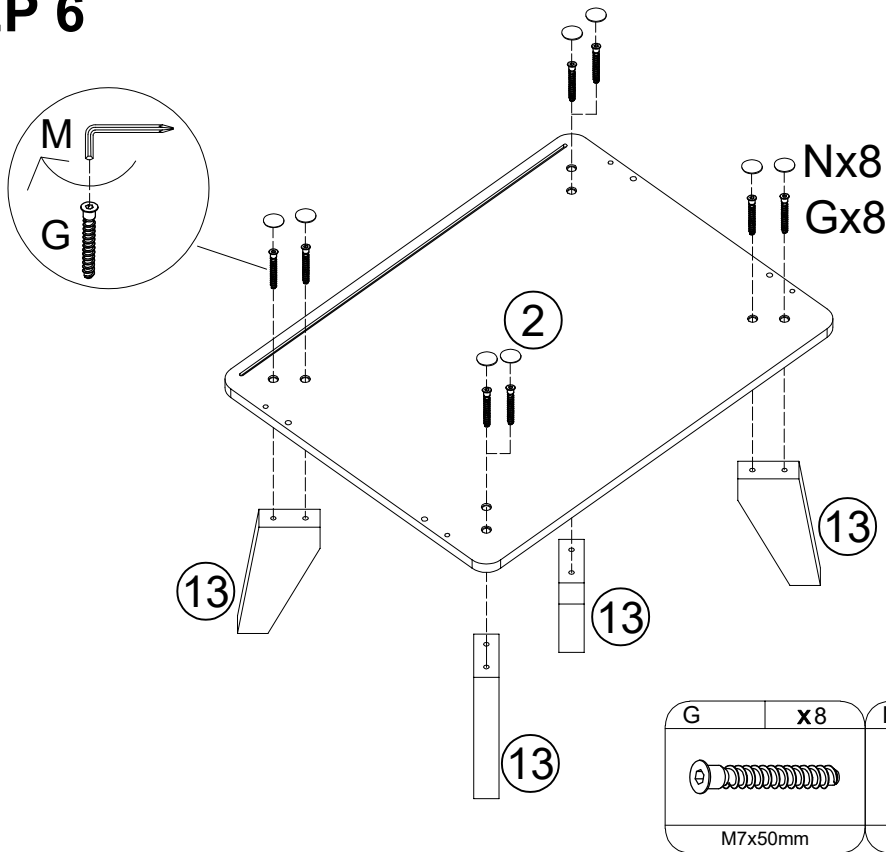

G	x8	N	x8	M	x1
M7x50mm		Ø20mm		4#	

STEP 7

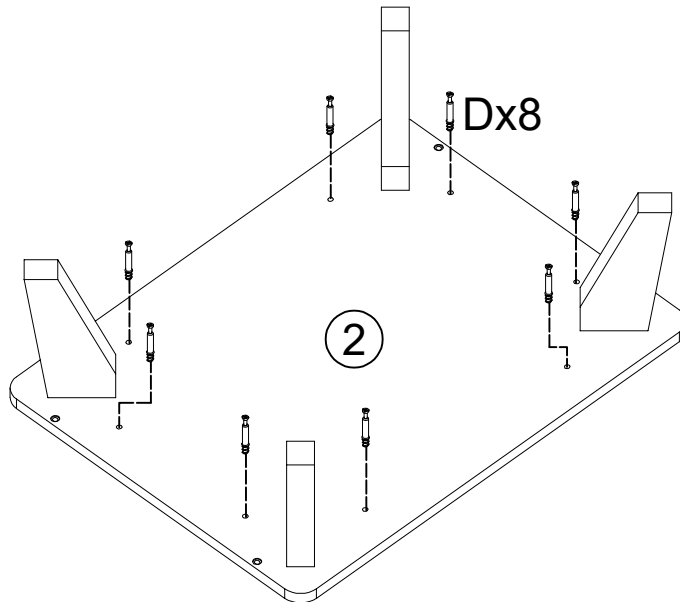

D	x8
M6x35mm	

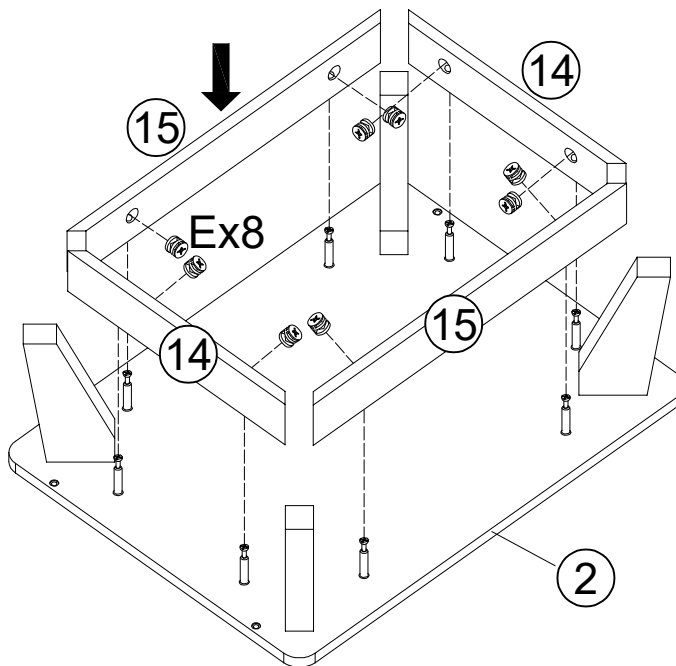

STEP 8

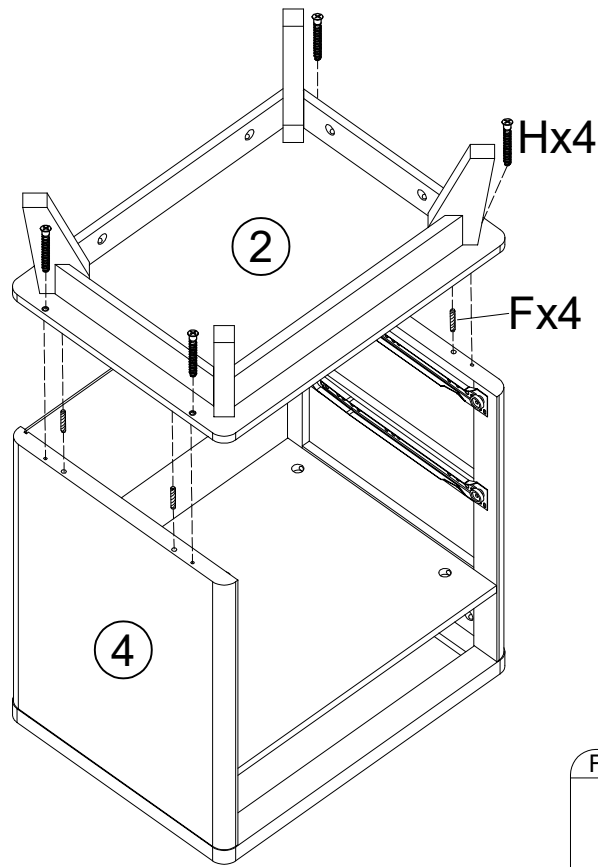

E	x8
Φ15mm	

STEP 9



F	x4	H	x4
			
Φ6x30mm		M5x40mm	

STEP 10

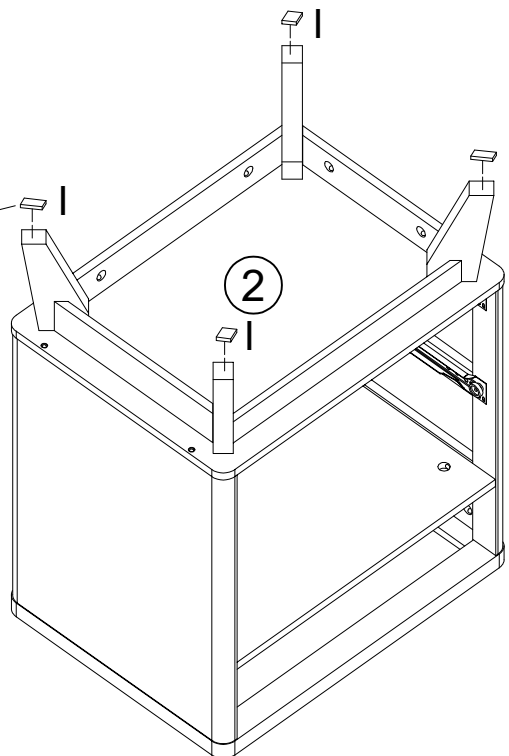
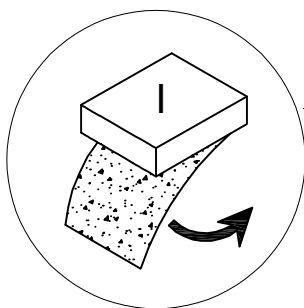

I	x4
	
EVA	

STEP 11

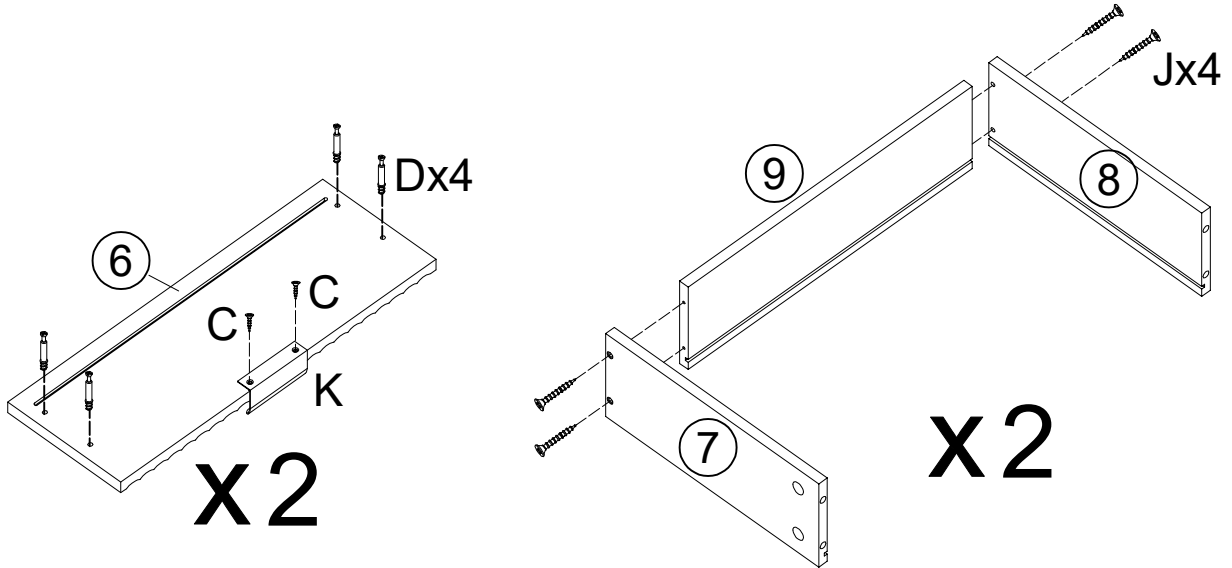

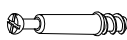
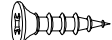
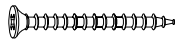
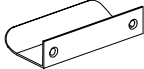
D	x8	C	x4	J	x8	K	x2
							
M6x35mm		M3.5x12mm		M4x40mm			

STEP 12

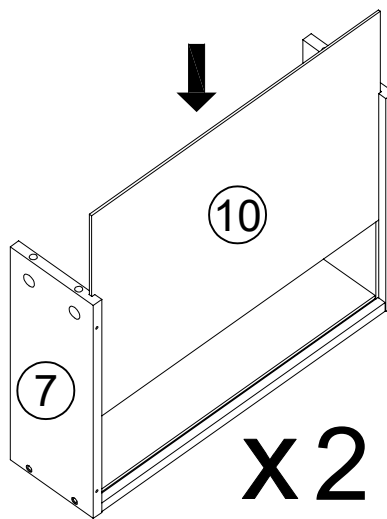

STEP 13

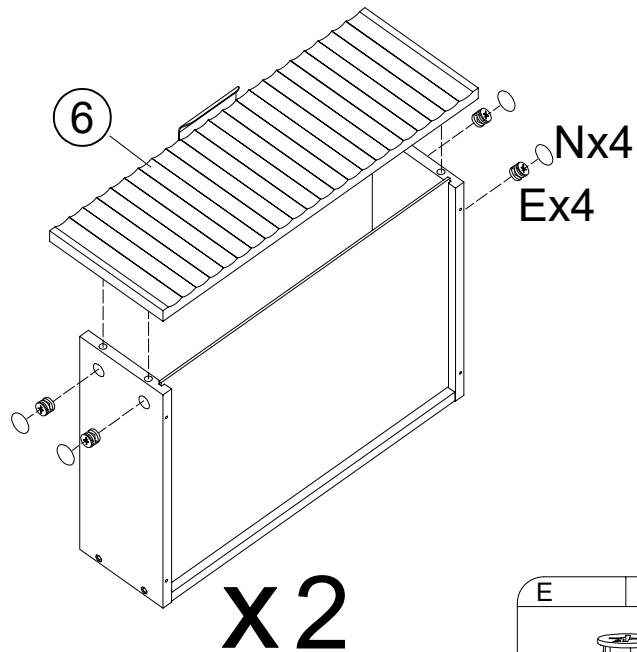

E	x8	N	x8
Φ15mm		Φ20mm	

STEP 14

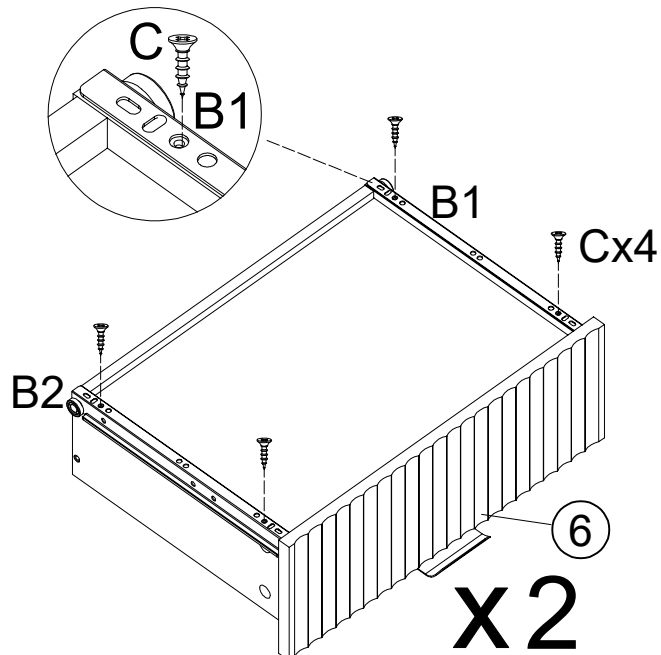

C	x8	B1	x2	B2	x2
M3.5x12mm					

STEP 15

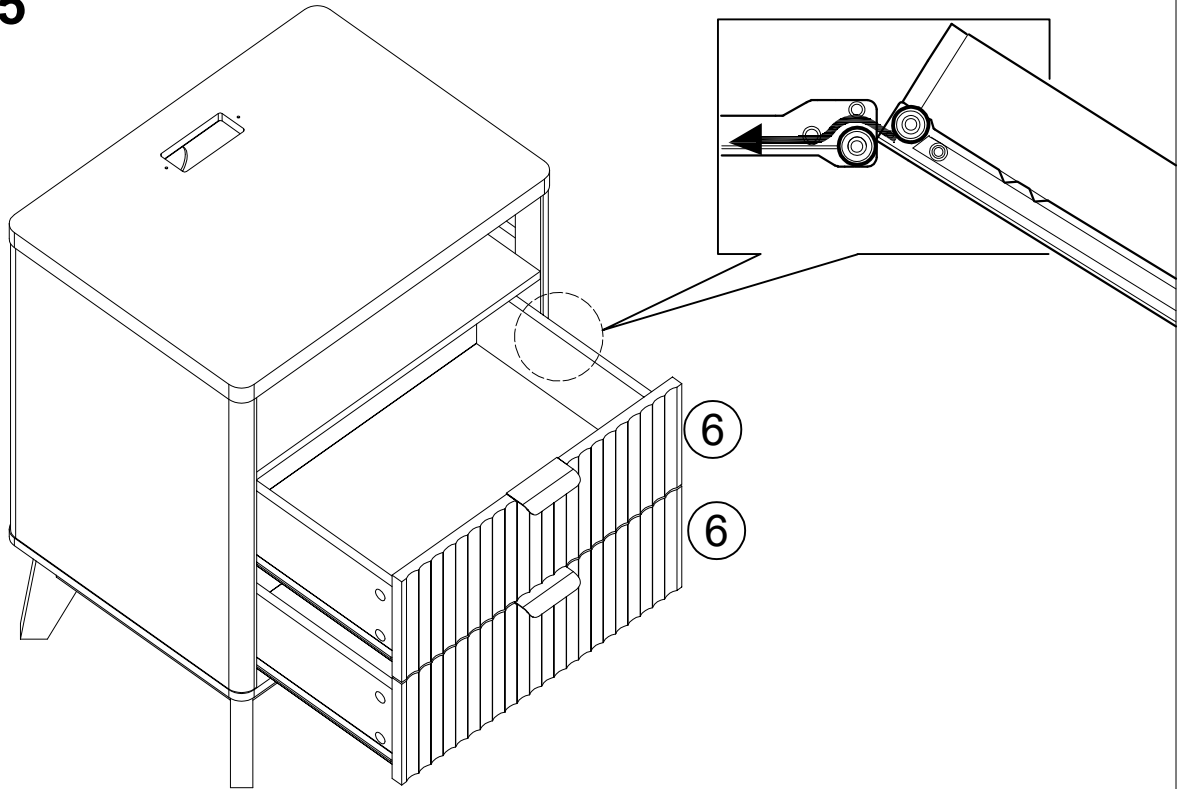

STEP 16

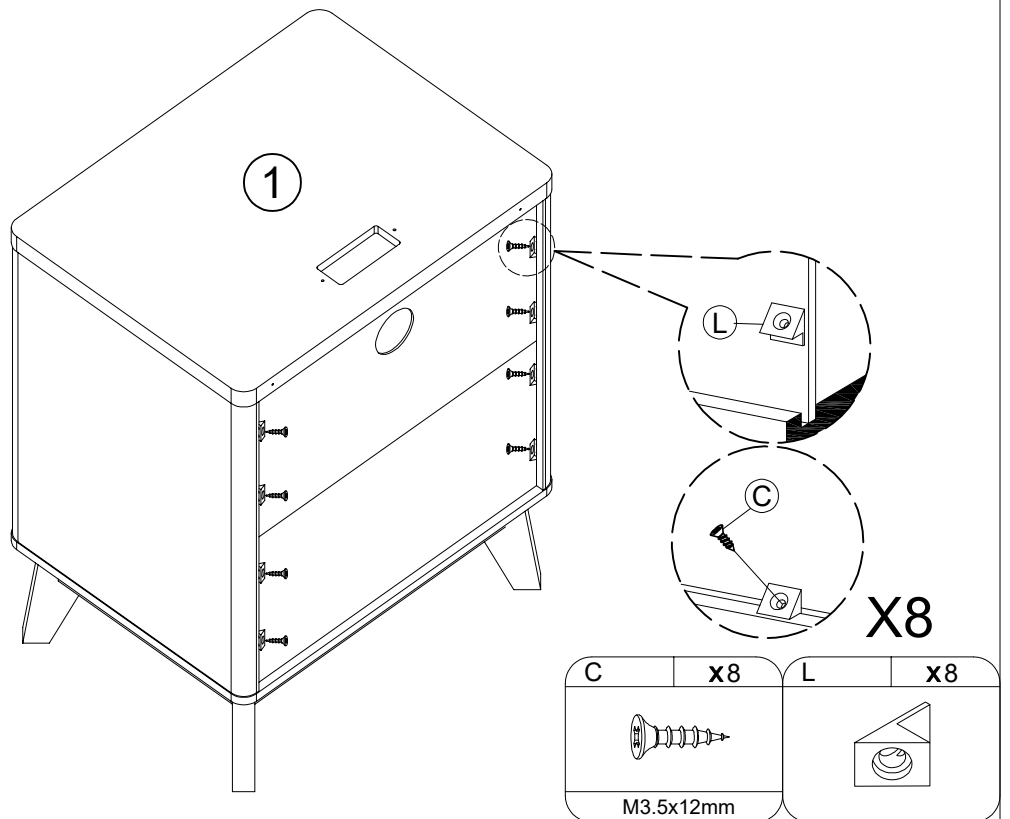

STEP 17

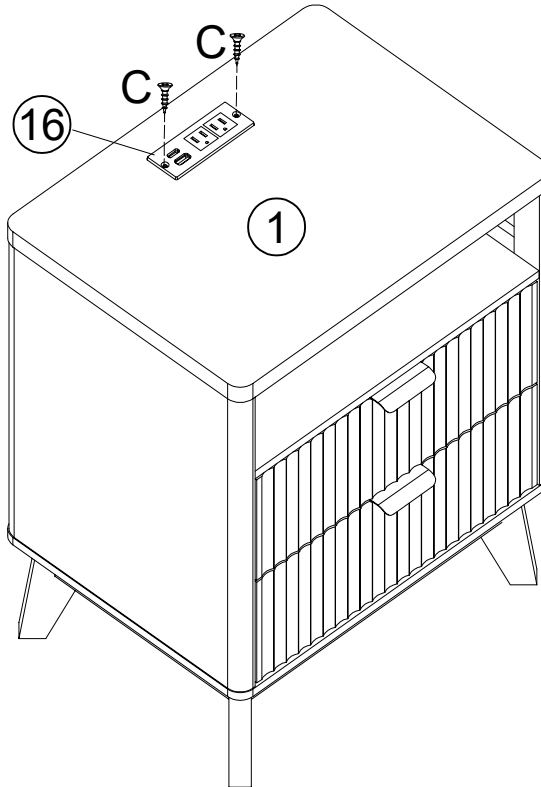

C	x2
M3.5x12mm	

STEP 18

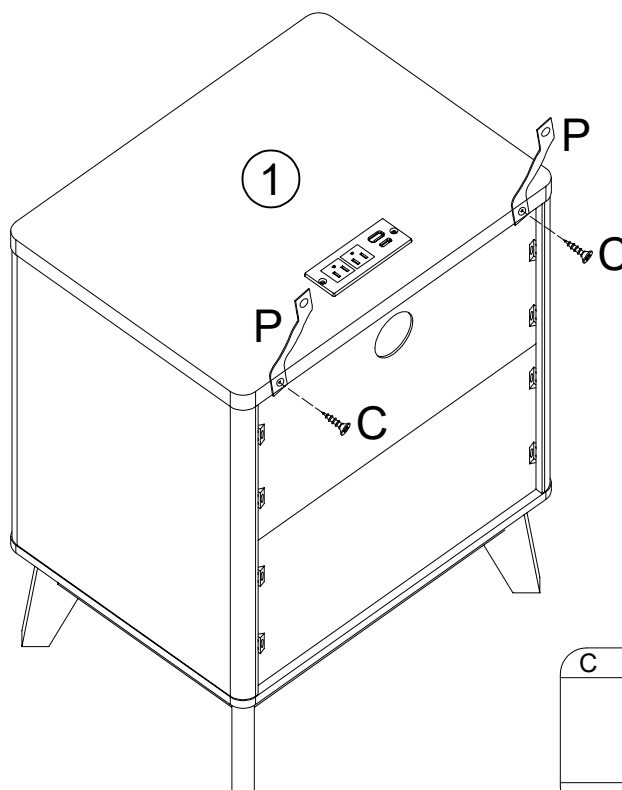

C	x2	P	x2
M3.5x12mm			

STEP 19

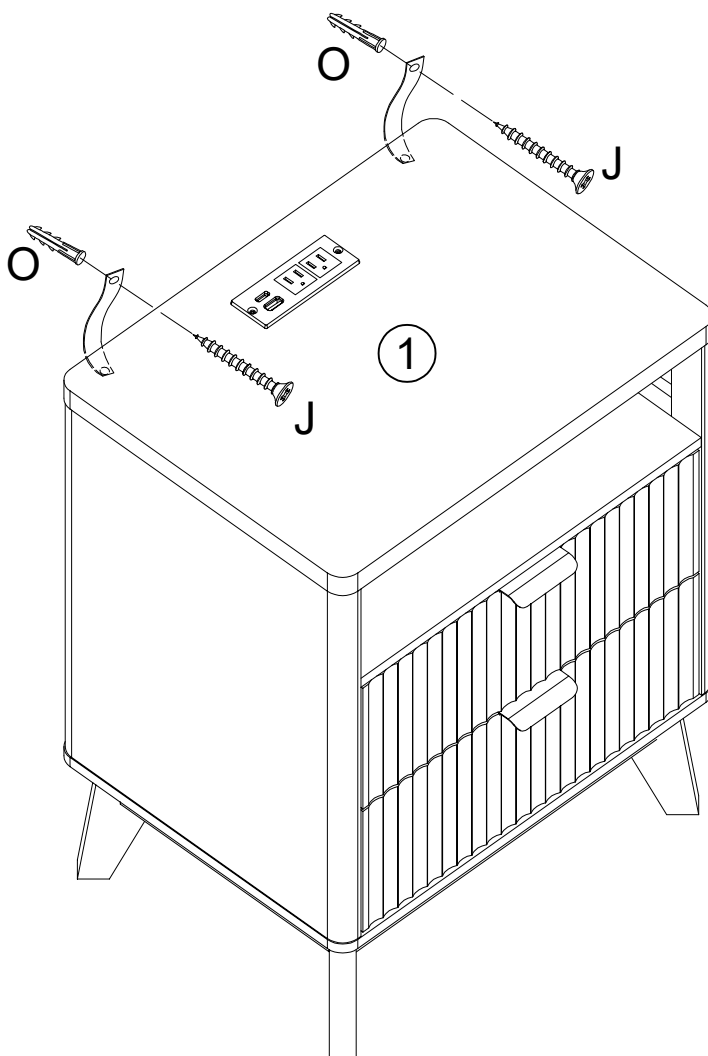

O	x2	J	x2
