

Golf Cage Assembly Instructions

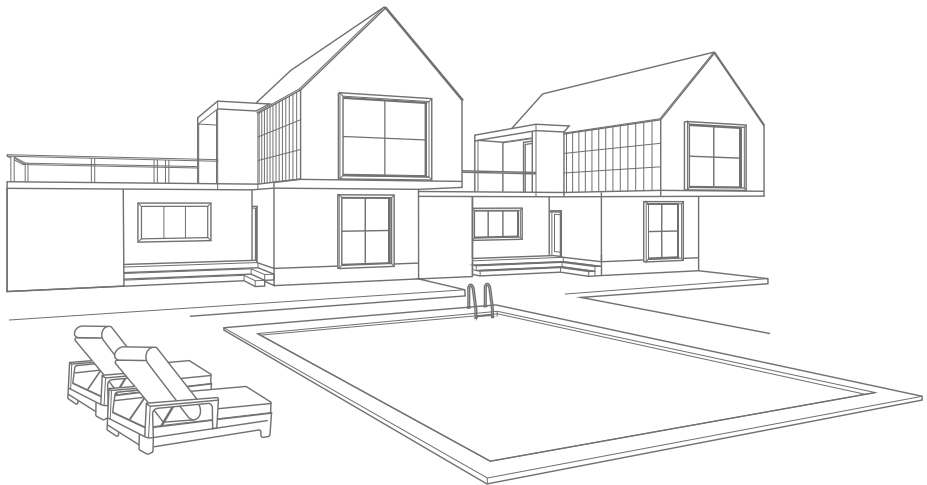









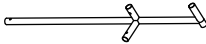





Scan for Support
support@garvee.com

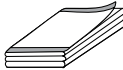

Distributed by
GARVEE.com

Package Includes:

1		1pcs
2		1pcs
3		2pcs
4		4pcs
5		9pcs
6		9pcs
7		2pcs
8		2pcs
9		2pcs
10		1pcs
11		1pcs
12		2pcs
13		32pcs
14		2pcs
15		2pcs
16		2pcs

Step 1

Connect the left-side poles of the Golf Cage according to the labels on the poles, as shown in the diagram.

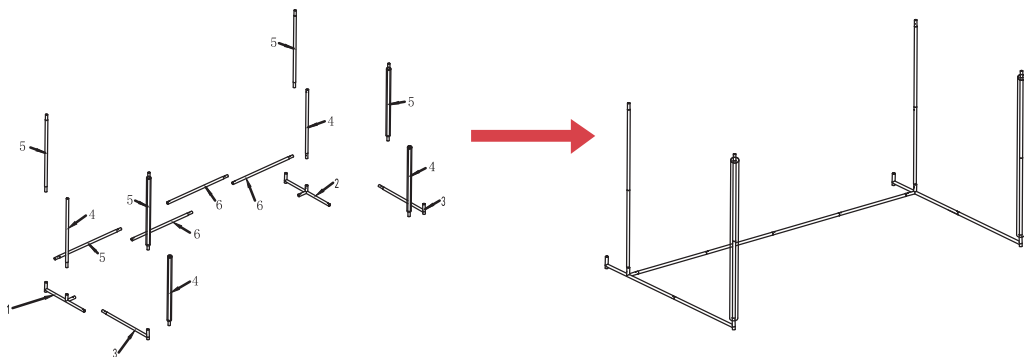

Step 2

Connect the right-side poles of the Golf Cage according to the labels on the poles, as shown in the diagram.

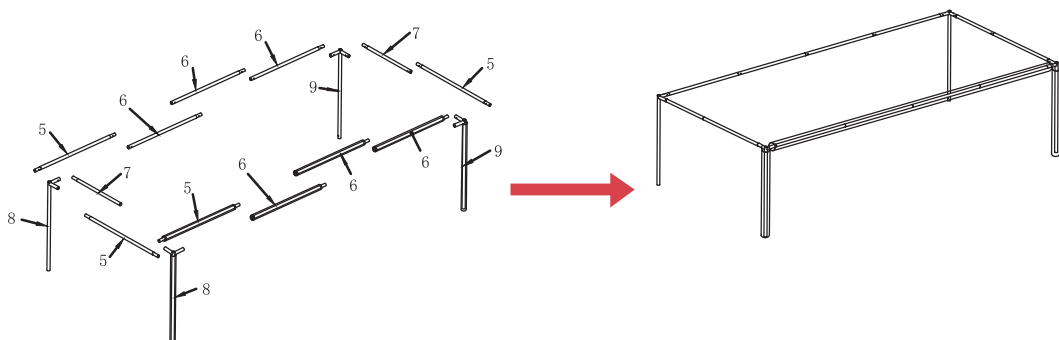

Step 3

Assemble the main frame of the Golf Cage using the labeled poles, as shown in the diagram.

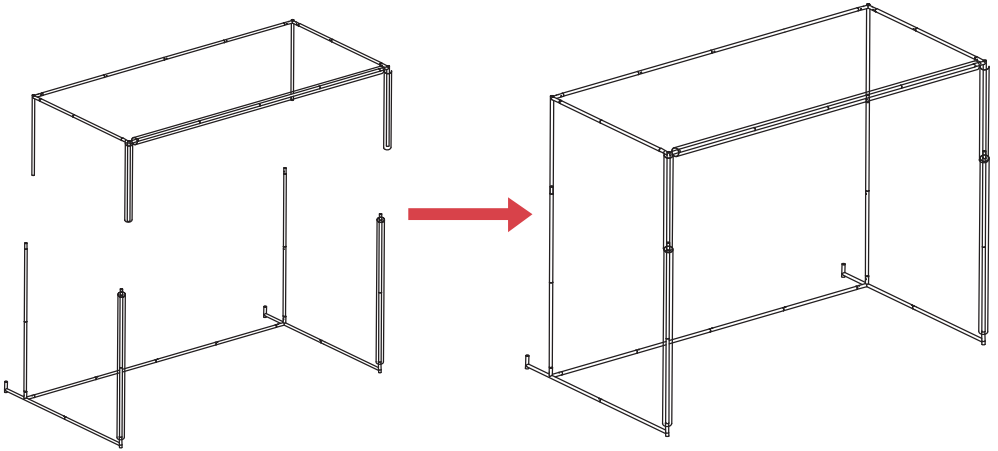

Step 4

Hang and cover the black cloth over the entire frame. Secure the edges of the four vertical poles using Velcro straps.

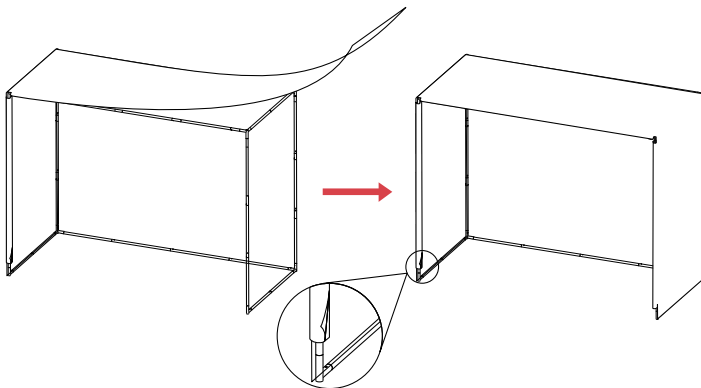

Note: Wrap and secure the edges with Velcro straps.

Step 5

Fix the blank simulator screen using elastic cords, as shown in the diagram.

 x 32

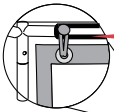

Note: Secure the screen with elastic bungee cords.

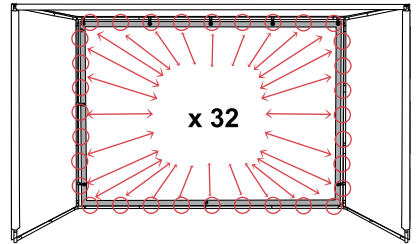
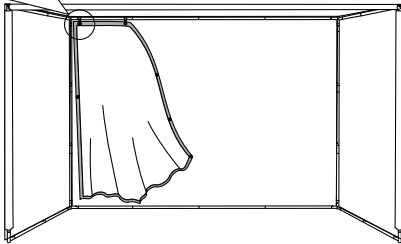

Step 6

Attach the protective strips

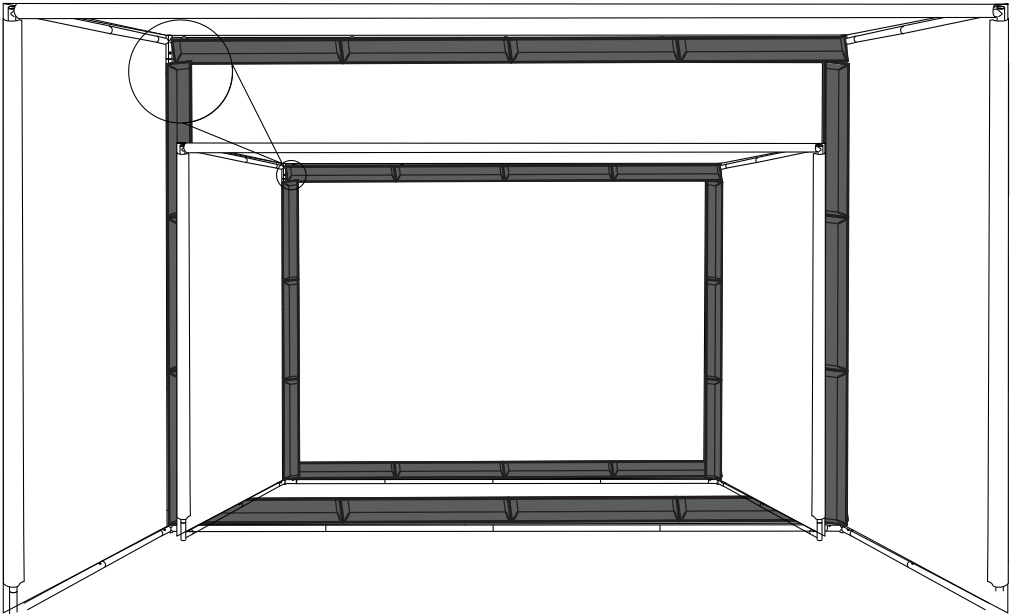

Step 7 Install the Side Barriers by attaching the top buckle and securing the bottom with Velcro straps.



Note:

Top buckle secured

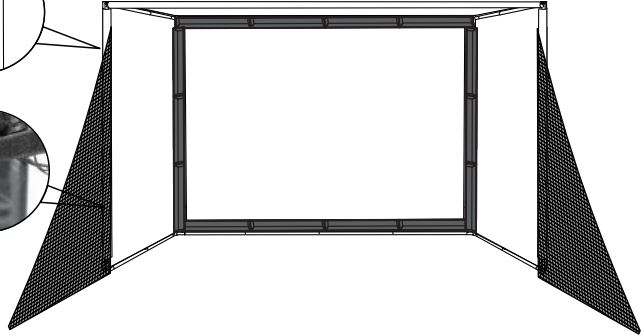
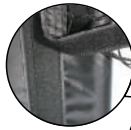
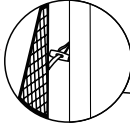

Note:

Velcro straps

Step 8

Connect the front of the Side Barriers to the sandbags using buckles. (Sandbags do not contain sand during transportation; please fill them yourself.) Once complete, your Golf Simulator Cage is fully assembled.



Note: Sandbag buckles connect to the Side Barriers



Final Assembly Complete!