

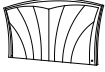











ASSEMBLY INSTRUCTIONS

QUEEN BED

(Box 1)
HEADBOARD & FOOTBOARD

No.	Description	Drawing	Qty.
A	Headboard		1 Pc
B	Left & Right Headboard Leg		2 Pcs
C	Footboard		1 Pc
D	Wooden Slat		4 Pcs
E	Wooden Support		4 Pcs
F	Bun Foot, Black Washer		2 Pcs
G	LED Adapter		1 Pc

(Box 1)
HEADBOARD HARDWARE LIST

No.	Description	Drawing	Qty.
1	Bolt(M8x35),Spring Washer, Flat Washer		8 Pcs
2	Bolt(M8x45),Spring Washer, Flat Washer		6 Pcs
3	Screw M4x32		8 Pcs
4	Allen Key M5		1 Pc
5	Philips head screwdriver (not included).		

(Box 2)
SIDE RAIL

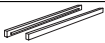
No.	Description	Drawing	Qty.
H	Side Rail		2 Pcs

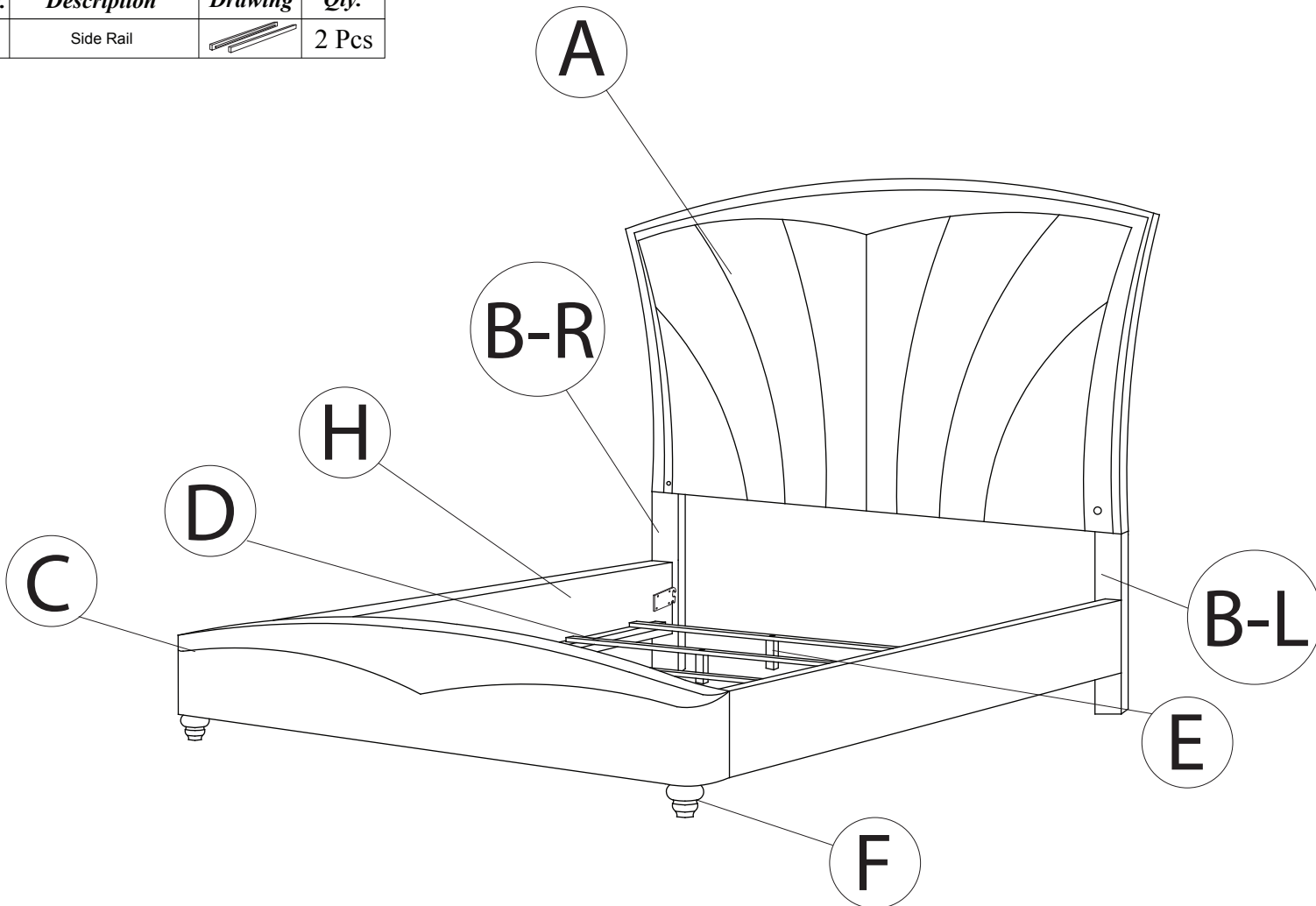

THE HARDWARE IS LOCATED IN THE PACKING ITEMS.

ASSEMBLY INSTRUCTIONS

STEP 1:

A. Attach headboard (A) & left & right headboard leg (B-L,R) by using bolt M8 x 45mm (2), spring washer (2), flat washer (2) and tighten by using allen key (4).

B. Unzip the fabric and attach LED adapter (G) to plug.

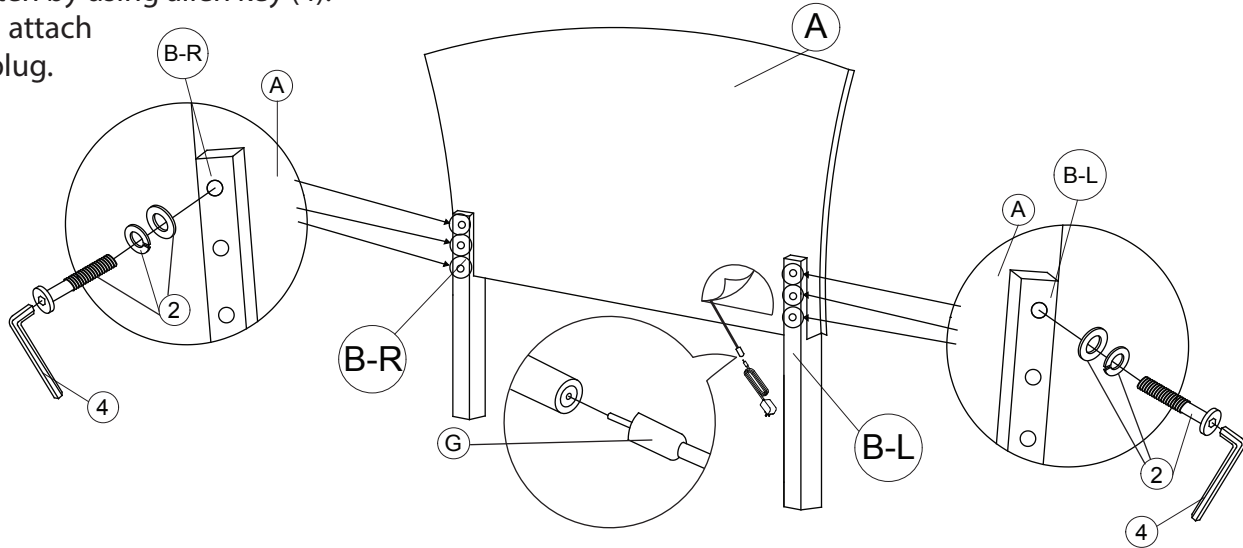

STEP 2:

Attach bun foot and black washer (F) to footboard (C).

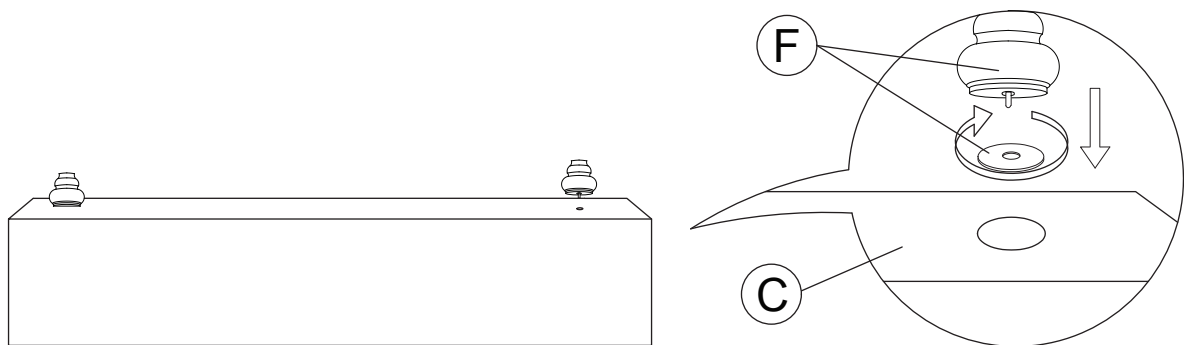

STEP 3:

Assembly side rails (H) to headboard (A) and headboard leg (B-L,R) by using bolt M8 x 35mm (1), spring washer (1), flat washer (1) and tighten by using allen key (4).

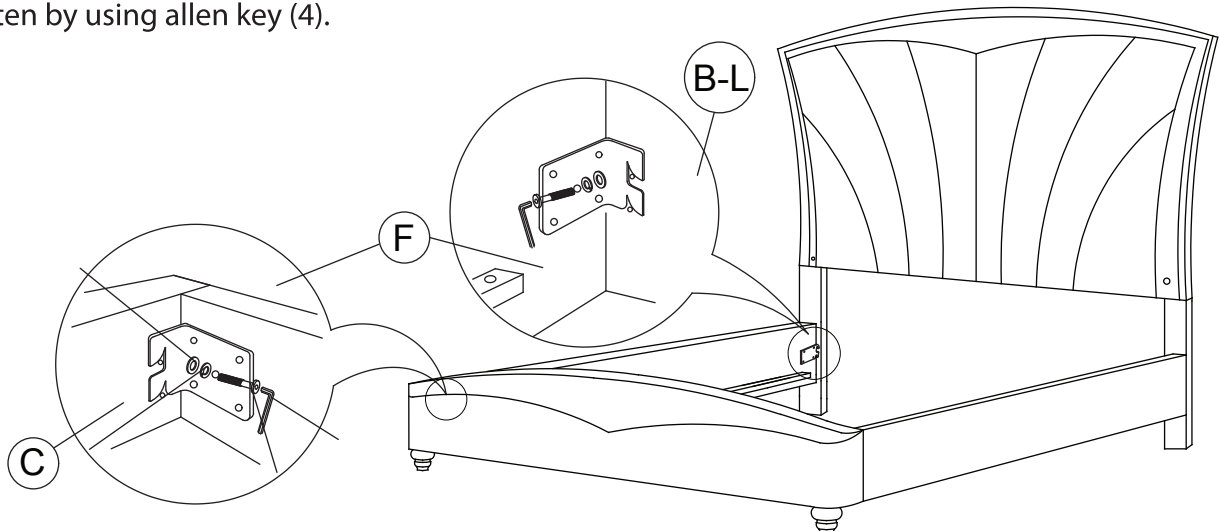

ASSEMBLY INSTRUCTIONS

STEP 4:

- A. Attach support legs (E) to slats (D). Then put slats rolls on middle of bed.
- B. Secure slats with screw (3) by philips head srewdriver (not included).

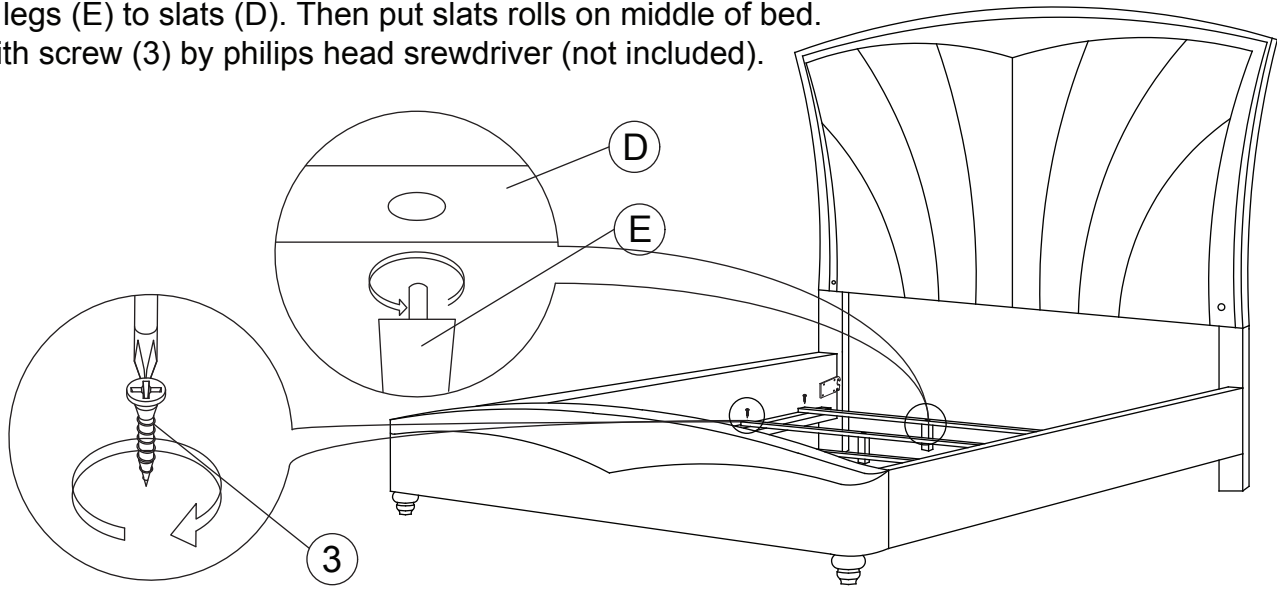

FINISHED

