

# Assembly Instructions

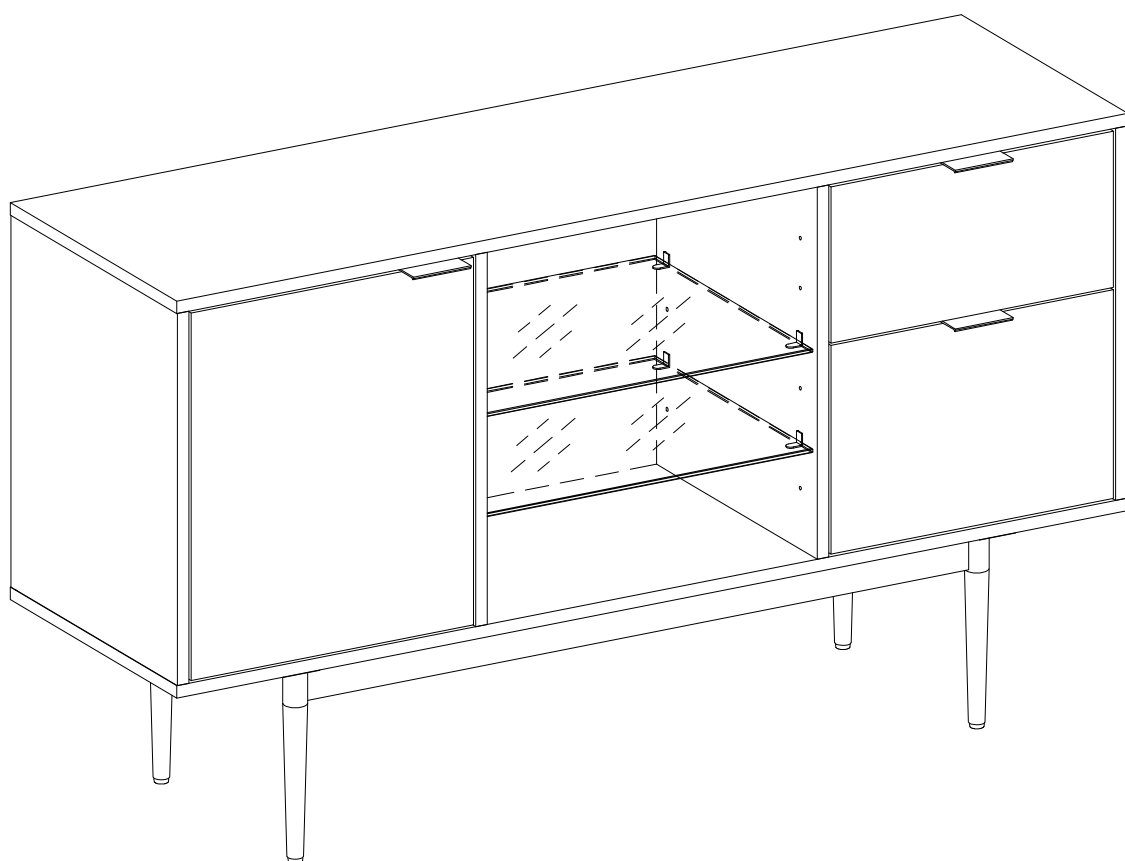

# General Assembly Guidelines

- I. Ensure that all parts and hardware are available before beginning assembly.
- II. Follow each step carefully to ensure the proper assembly of this product.
- III. Two people are recommended for ease in the assembly of this product.
- IV. The three main types of hardware used to assemble this product are : wood dowels , screws and bolts.
- V. The provided glue is to secure wood dowels in place . When first inserting dowels , locate the appropriate hole for the dowel , place a small amount of glue in the hole and insert the dowel . Wipe away excess glue immediately.

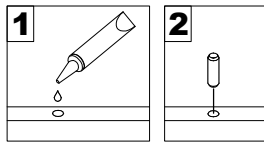

In future assembly steps when dowels are necessary to attach assembly parts together , place a small amount of glue on the end of the dowel before attaching parts together . Wipe away excess glue immediately.

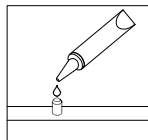

- VI. A Phillips head screwdriver is required for the assembly of this product .

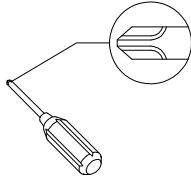

- VII. Power tools should not be used to assemble this product .

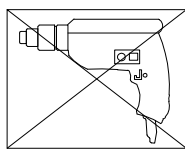

- VIII. Concealed hinges are three-way adjustable.

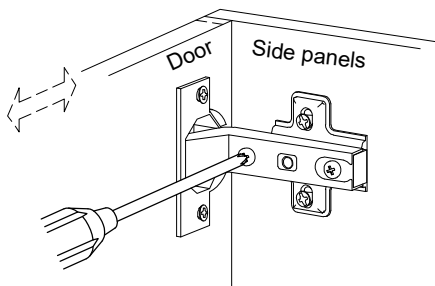

Horizontal  
by screw adjustment

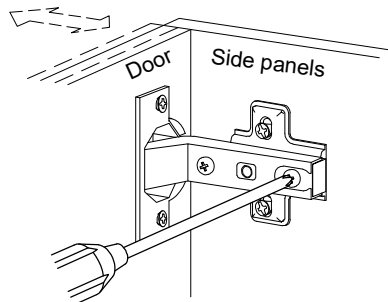

In-and-Out  
by loosening the hinge-arm  
mounting screw or via cam  
adjustment

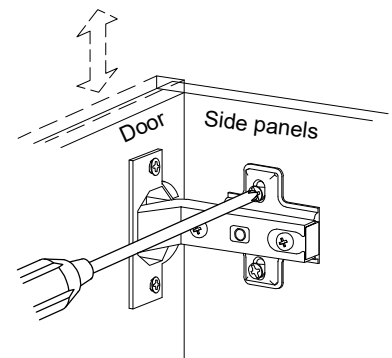





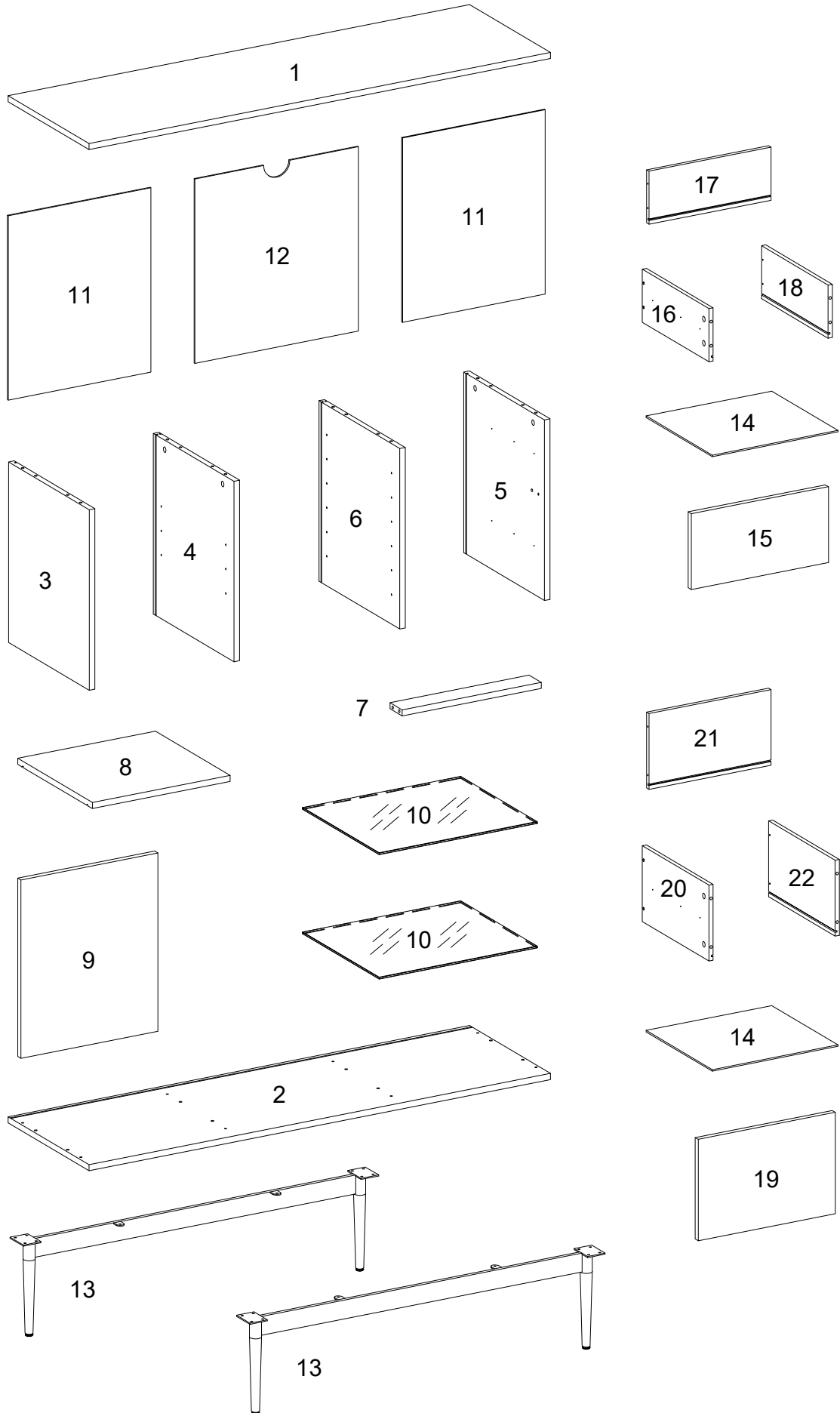



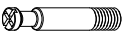



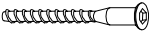





Vertical  
Via slots in the mounting  
plate or via cam adjustment

# Parts List



# Hardware List

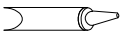

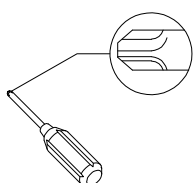
A		Ø8x30mm	Wooden dowel	18	pcs
B		Ø6x35mm	Cam bolt	18	pcs
C		Ø15x11mm	Cam lock	10	pcs
D		Ø15x9mm	Cam lock	8	pcs
E			Sticker	18	pcs
F		Ø6x50mm	Screw	8	pcs
G		Ø6x12mm	Bolt	20	pcs
H		M4	Hex Key	1	pc
J			L shape shelf support pin	8	pcs
K			Shelf support pin	4	pcs
L			Handle	3	pcs
M			Europe hinge	2	pcs
N		Ø3.5x14mm	Screw	12	pcs
P		Ø4x32mm	Screw	8	pcs
Q			Plastic wedge	12	pcs
R		Ø3x17mm	Screw	12	pcs
S		Ø4x12mm	Screw	2	pcs
T		Ø4x25mm	Screw	2	pcs
U			Plastic strap	2	pcs
V			Nut	2	pcs
W			Glue tube	1	pc



Philips head screwdriver required for assembly  
(not included)

*The hardware quantities listed above are required for proper assembly.  
Some extra hardware may also have been included.*

# Hardware List

X		Ø3x12mm	Screw	30	pcs
Y			Drawer slider <small>*Note: This piece comes preassembled for shipping purposes and must be disassembled to complete the desk assembly.</small>	2	sets

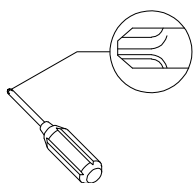

Philips head screwdriver required for assembly  
(not included)

*The hardware quantities listed above are required for proper assembly.  
Some extra hardware may also have been included.*

# Step 1

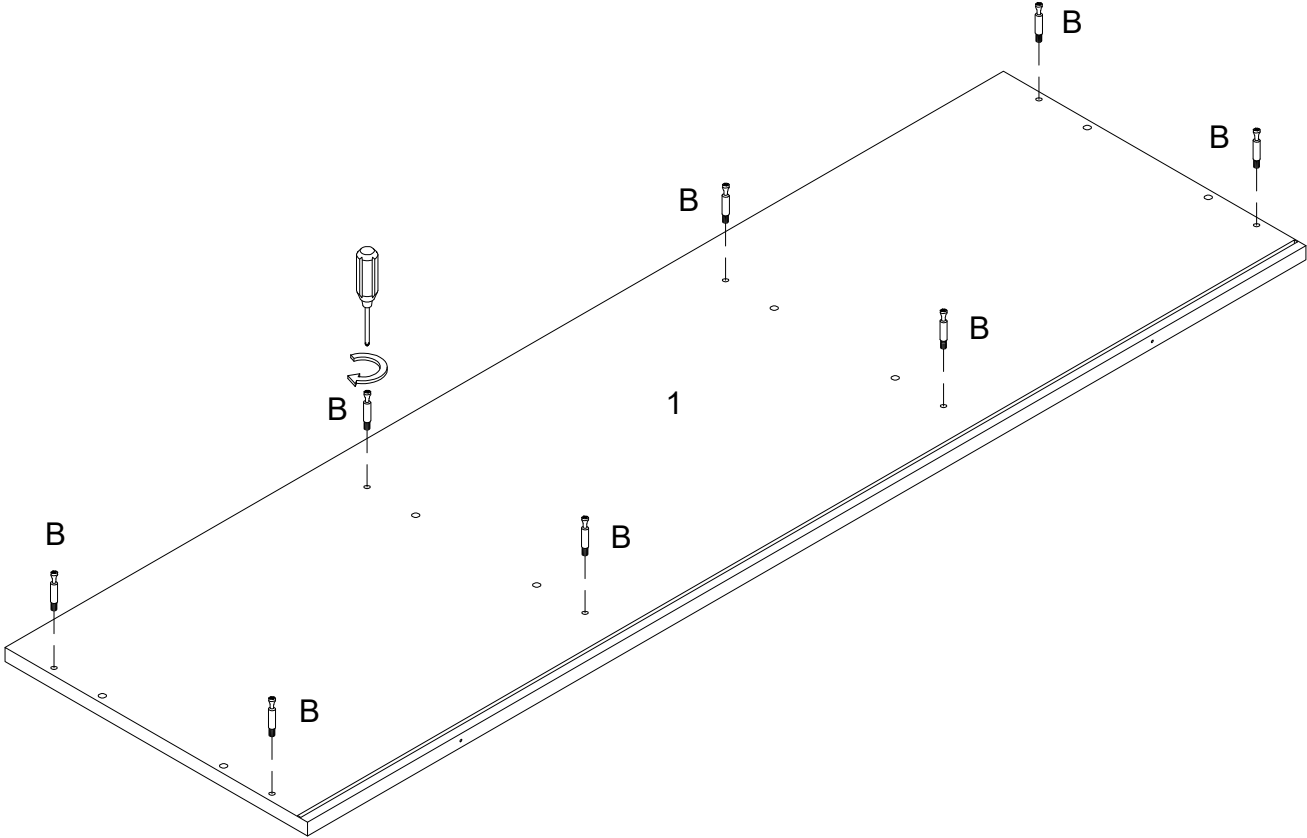

Secure cam bolt (B) into part (1) with Philips head screwdriver as per diagram.

# Step 2

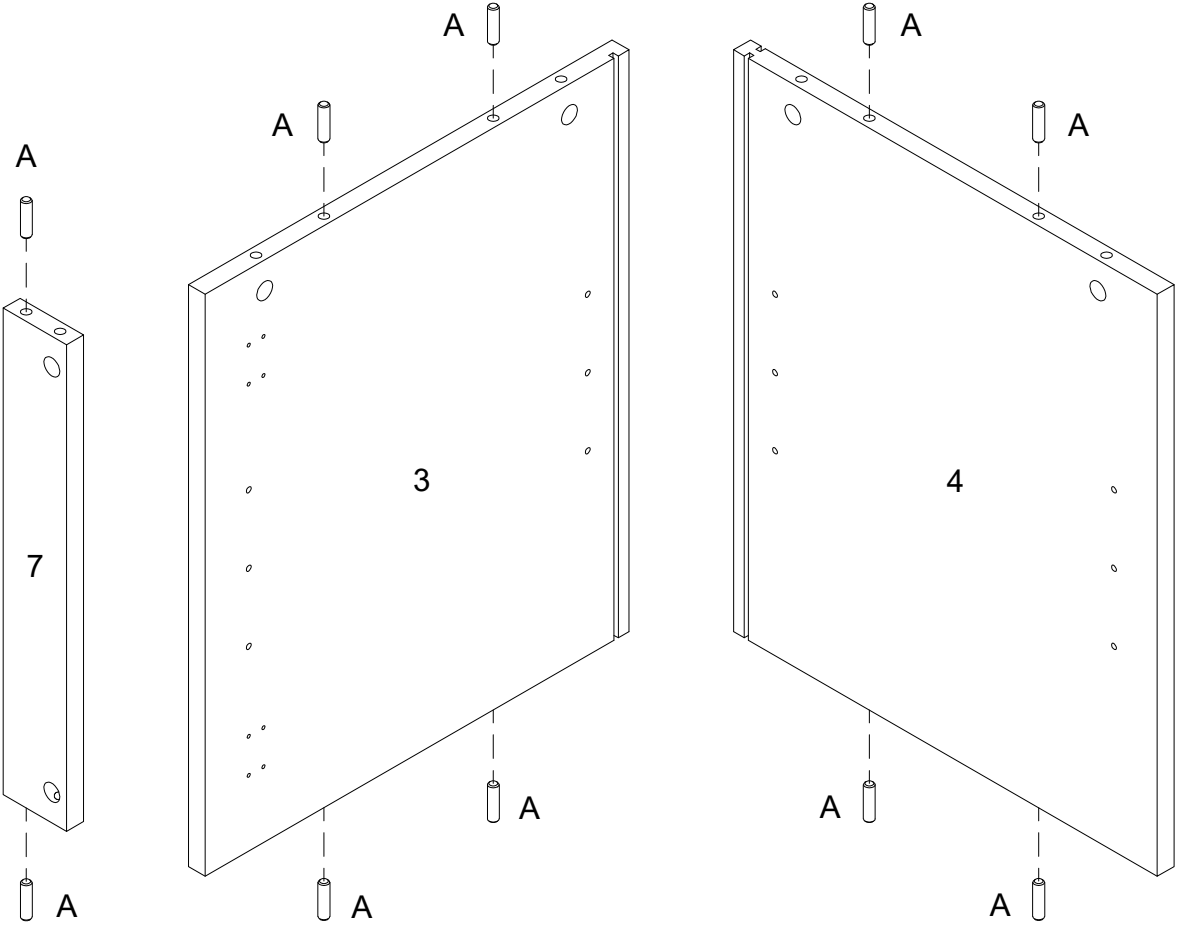

Insert wooden dowel (A) into parts (3,4,7) as per diagram.

# Step 3

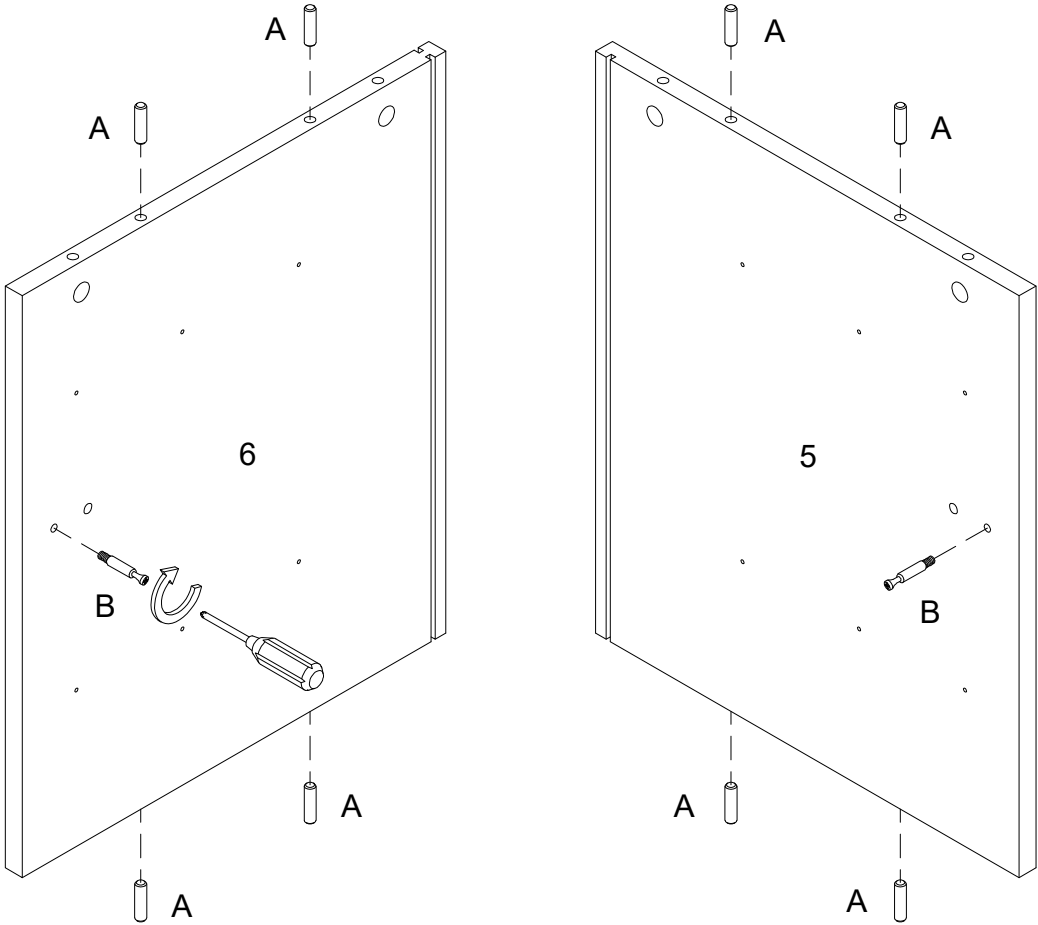

Insert wooden dowel (A) into parts (5,6) ,then secure cam bolt (B) into parts (5,6) with Philips head screwdriver as per diagram.

# Step 4

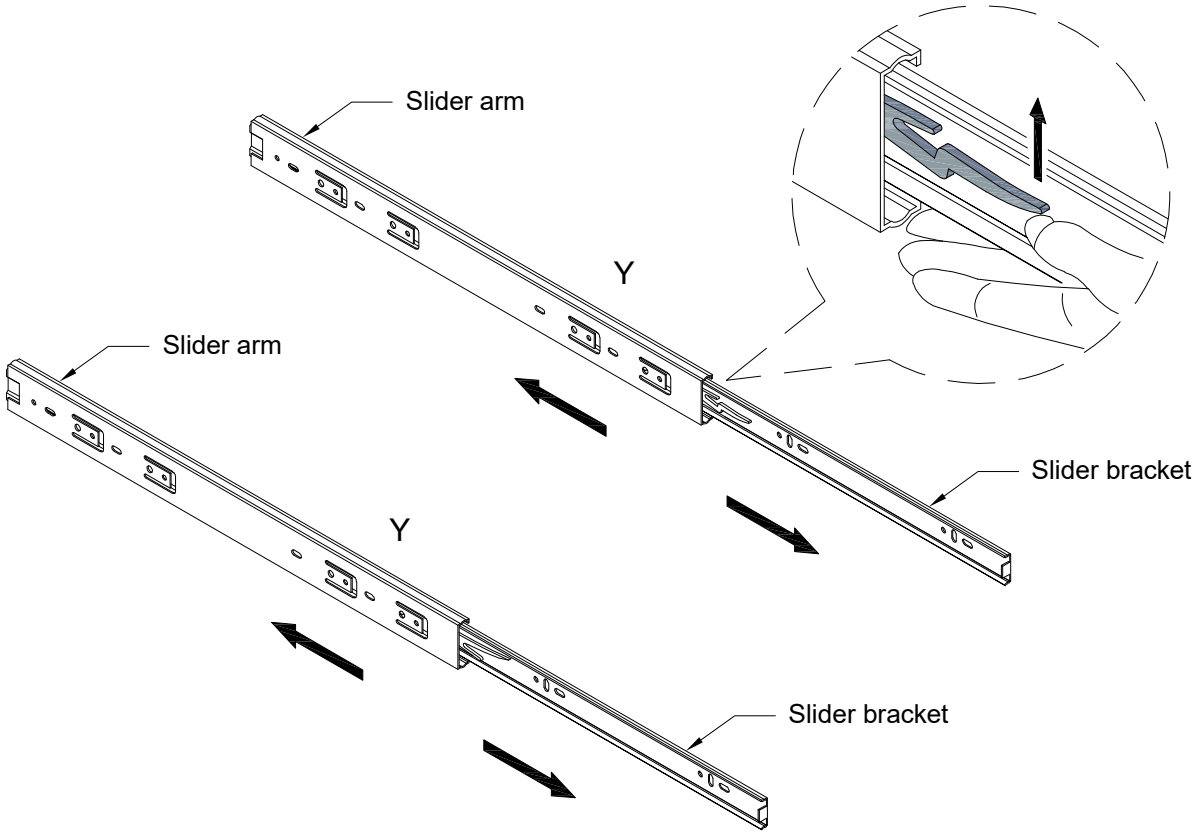

Separate the slide bracket from the slide arm as per diagram.

# Step 5

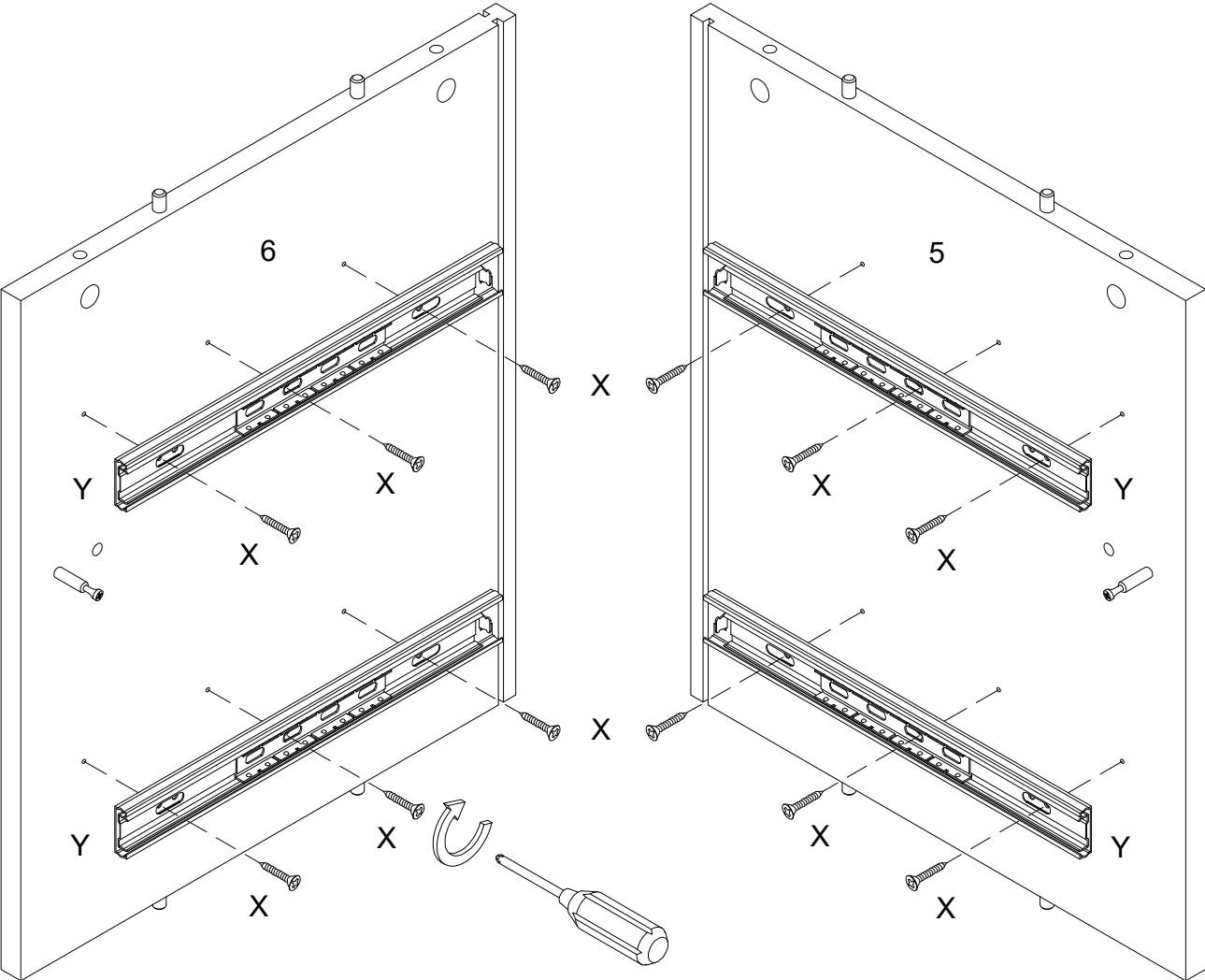

Using screw (X) attach drawer slider arm (Y) to parts (5,6) with Philips head screwdriver as per diagram.

# Step 6

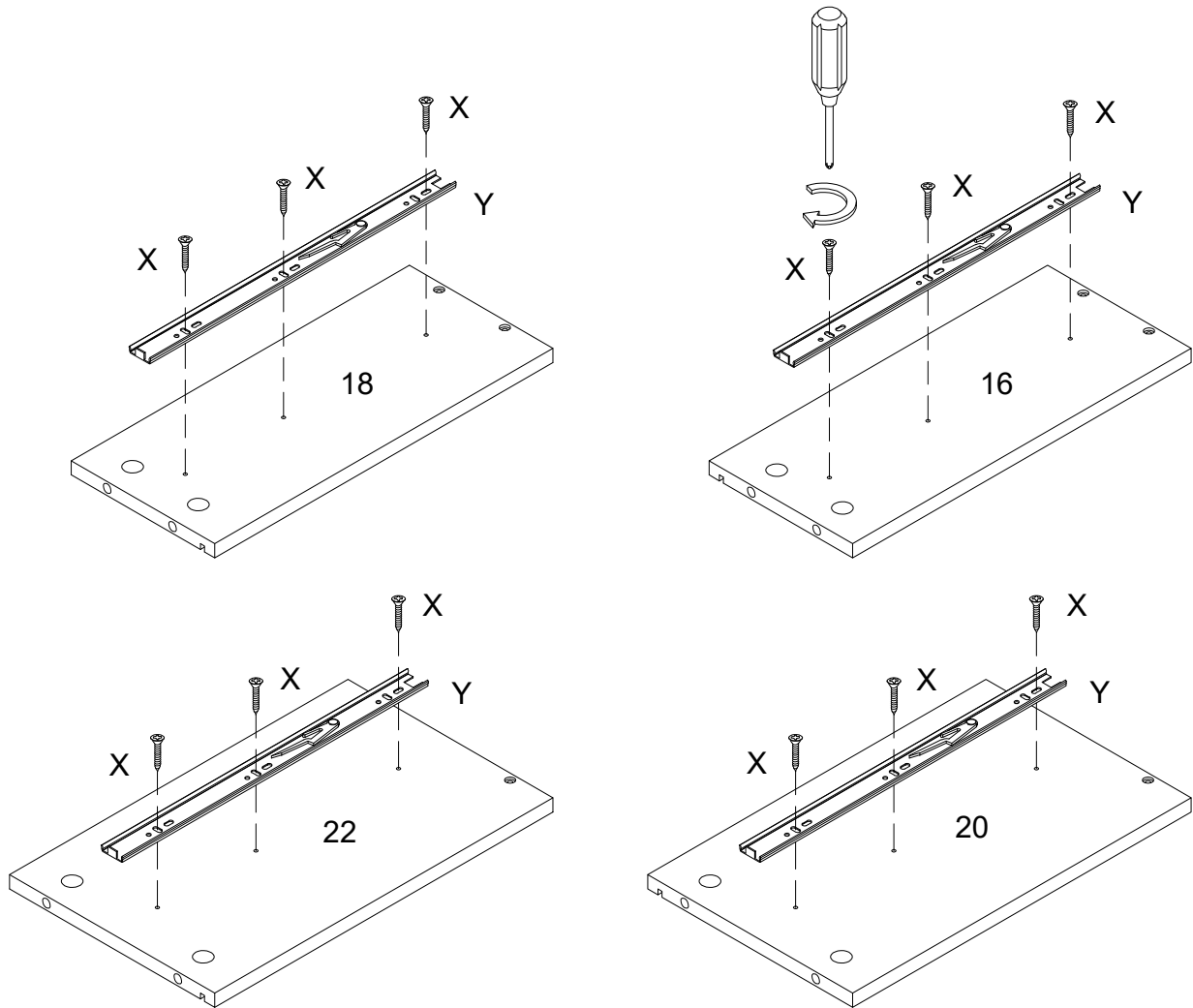

Using screw (X) attach drawer slider bracket (Y) to parts (16,18,20,22) with Philips head screwdriver as per diagram.

# Step 7

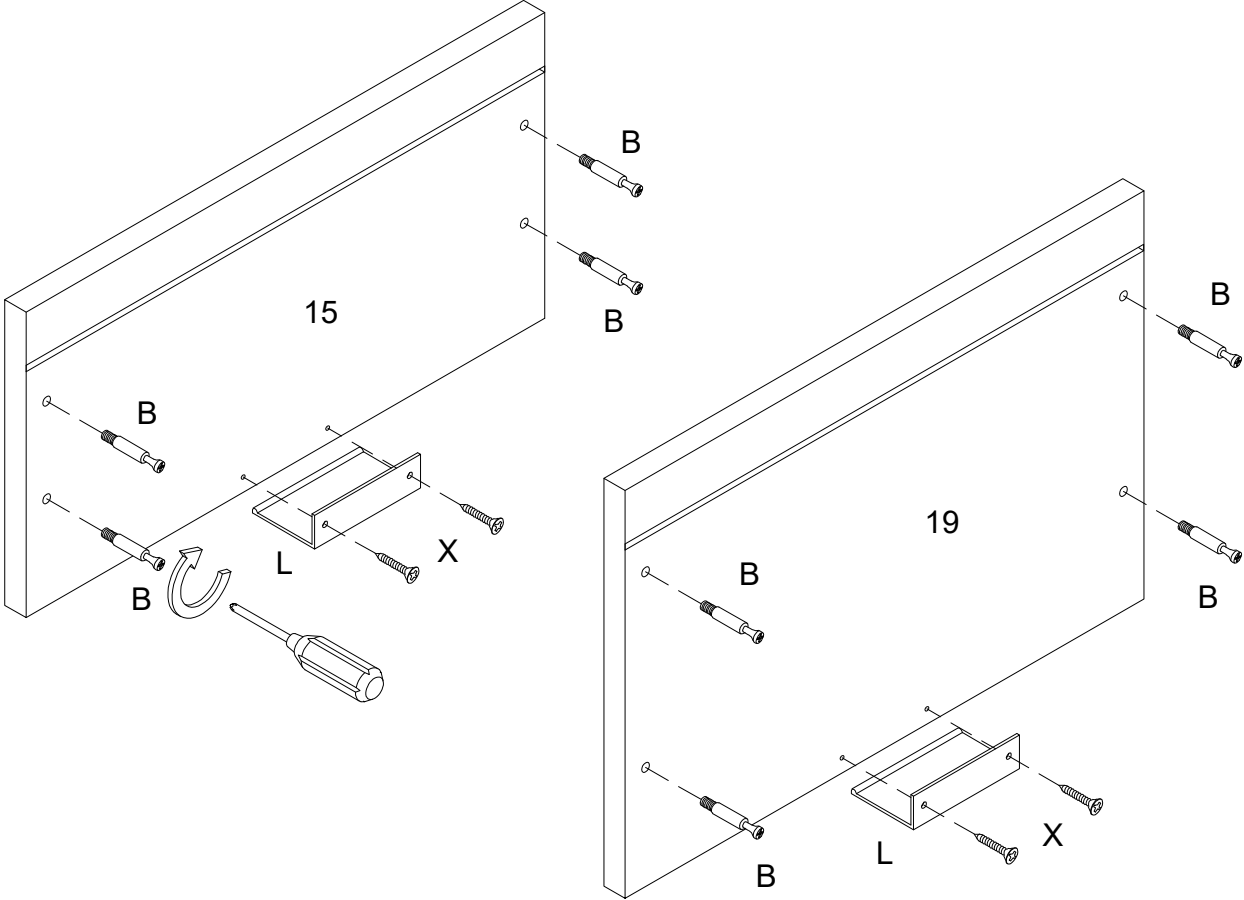

Secure cam bolt (B) into parts (15,19) ,then using screw (X) attach handle (L) to parts (15,19) with Philips head screwdriver as per diagram.

# Step 8

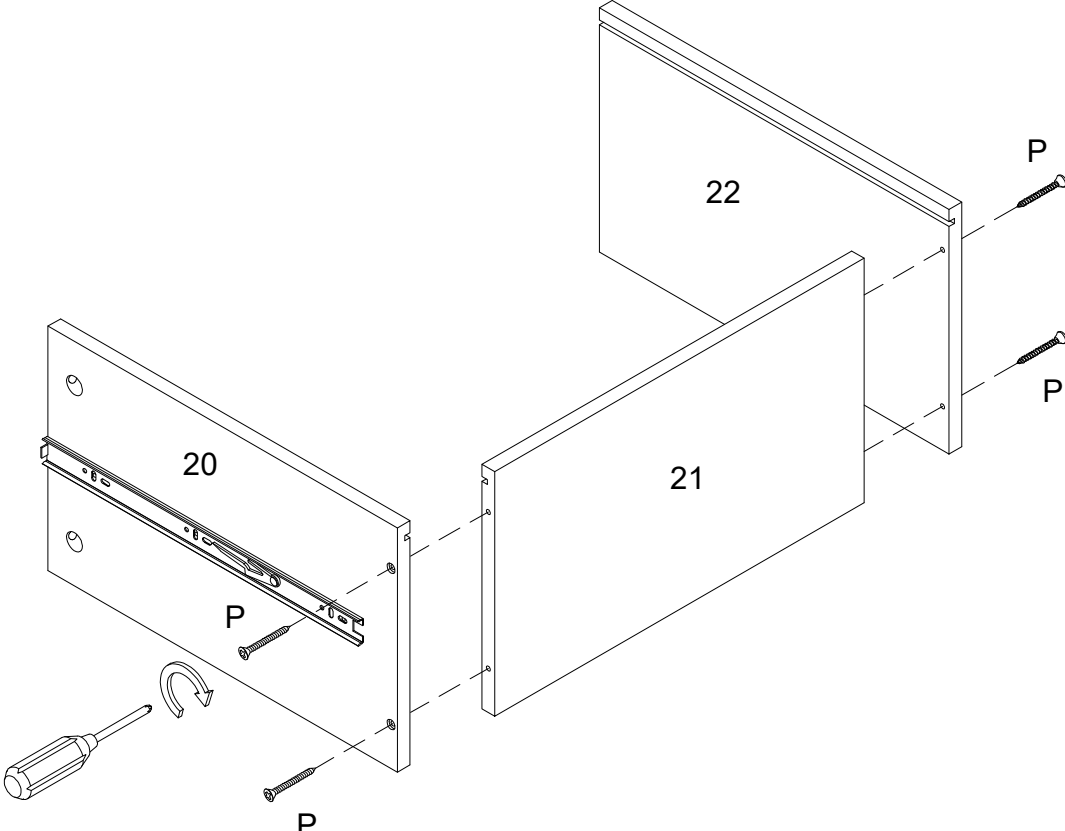

Using screw (P) attach part (20,22) to part (21) with Philips head screwdriver as per diagram.

# Step 9

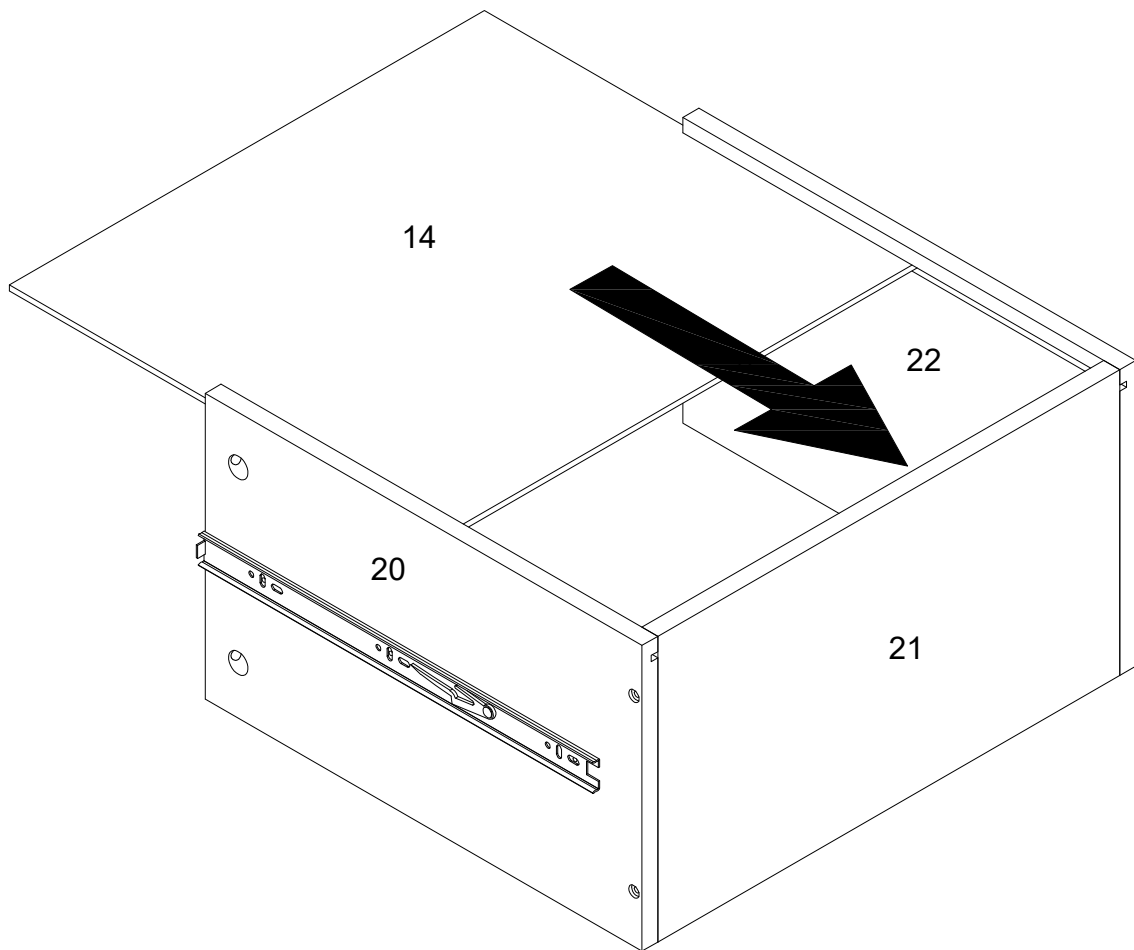

Put part (14) as per diagram.

# Step 10

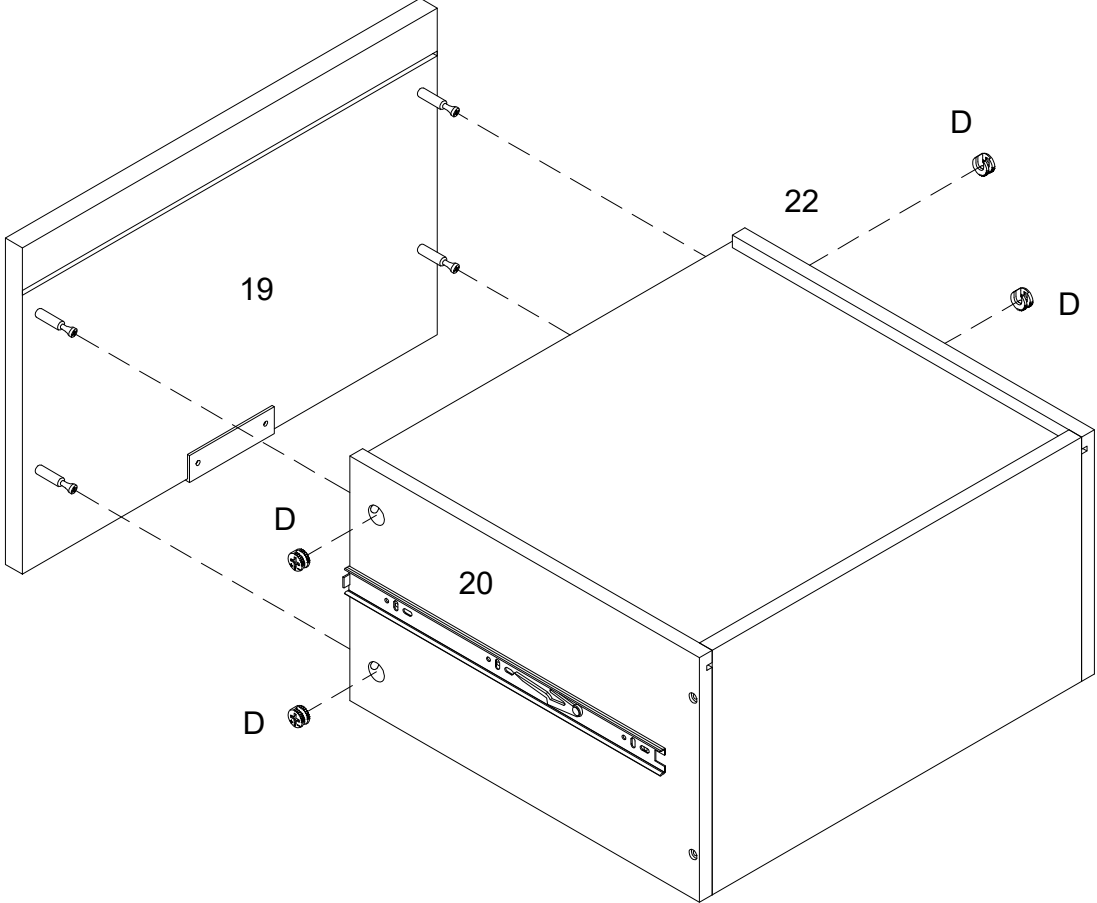
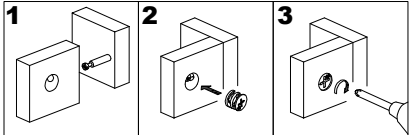

Using cam lock(D) secure part (19) to parts (20,22) with Philips head screwdriver as per diagram.

# Step 11

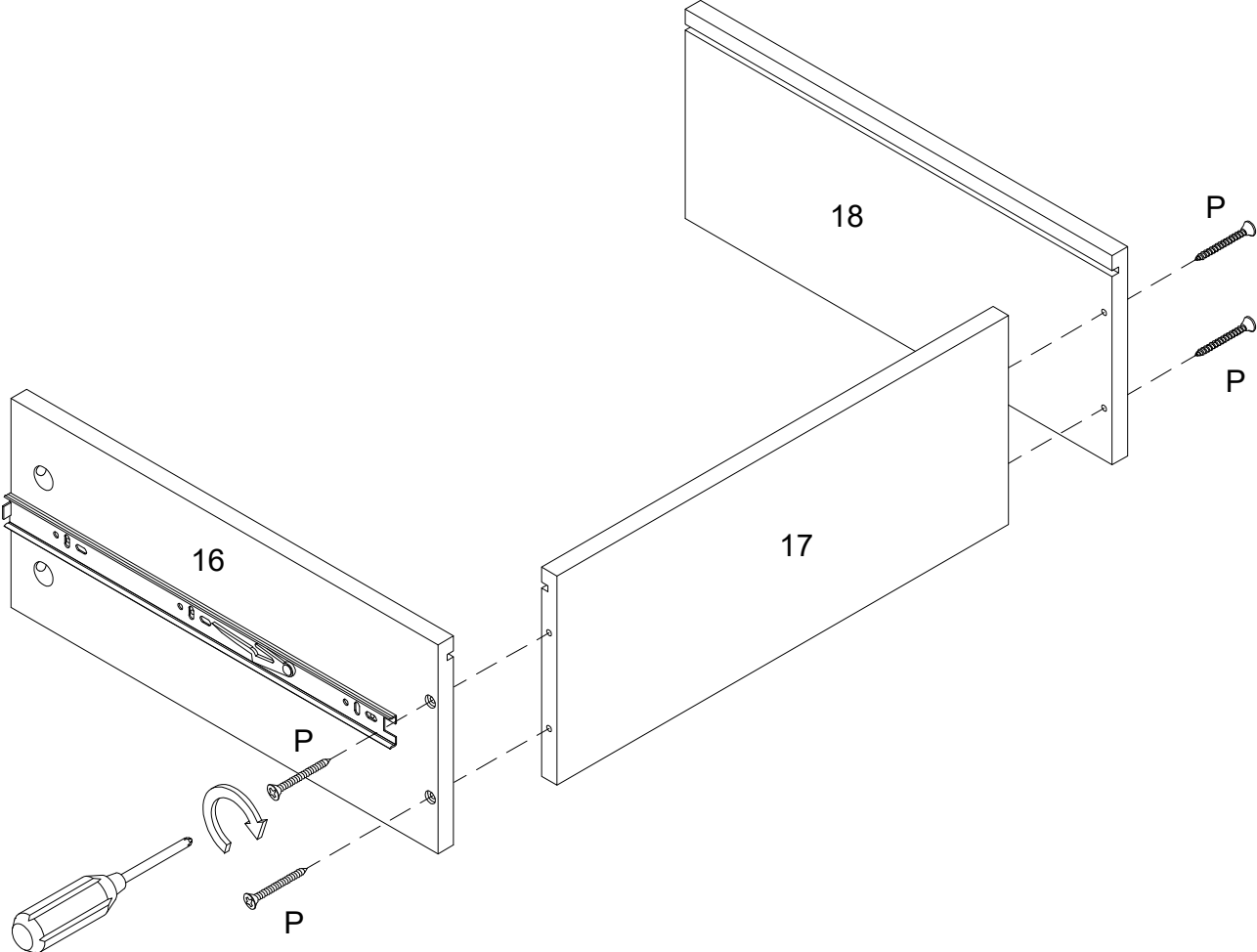

Using screw (P) attach part (16,18) to part (17) with Philips head screwdriver as per diagram.

# Step 12

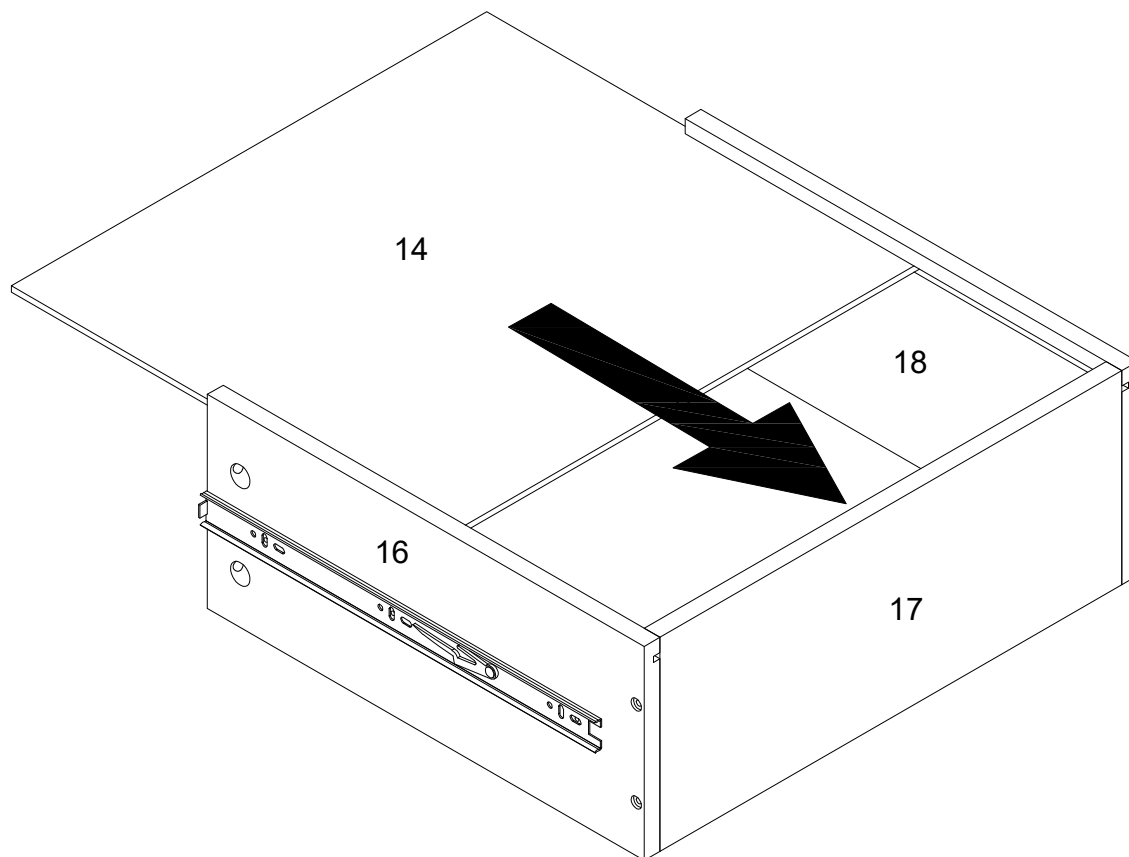

Put part (14) as per diagram.

# Step 13

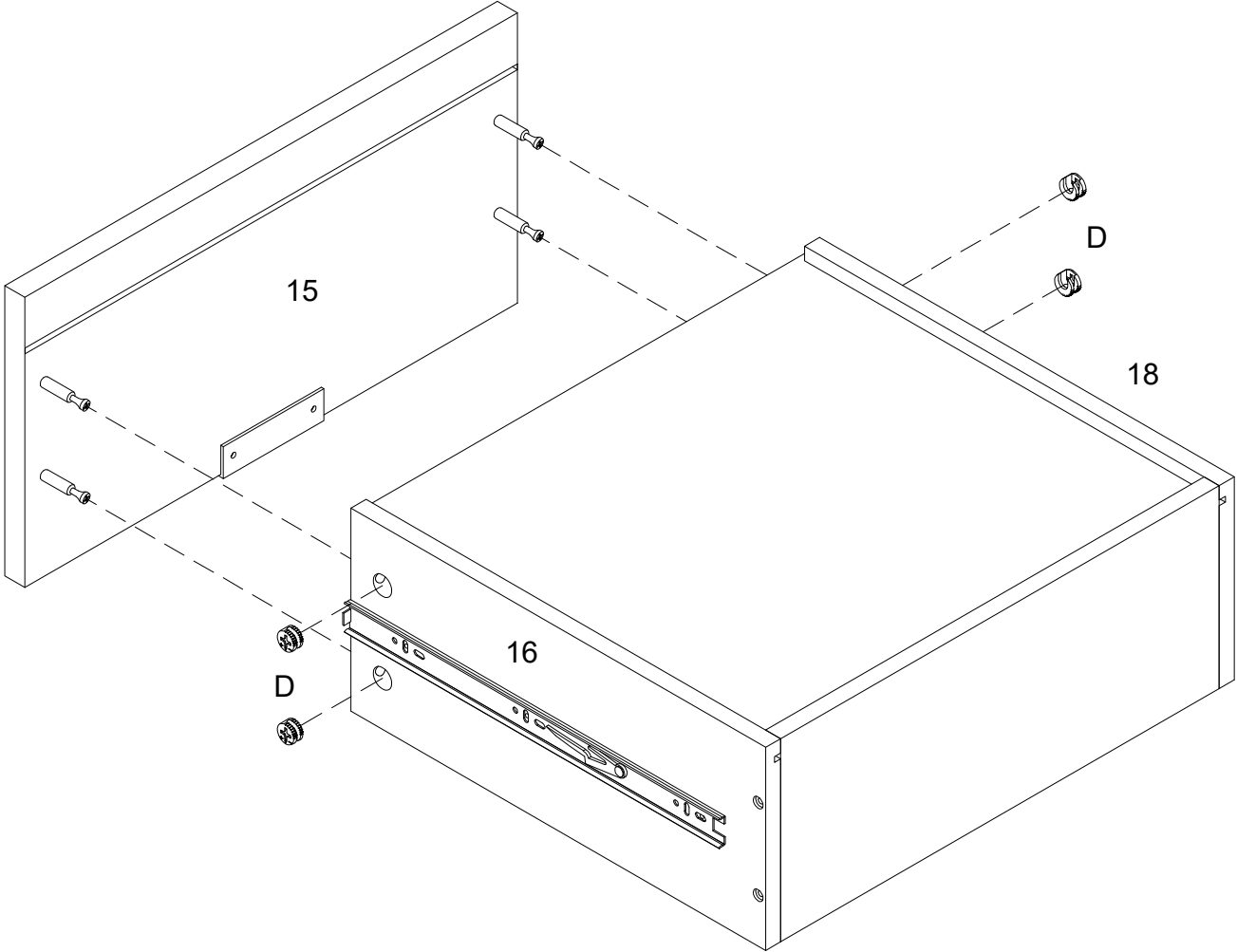
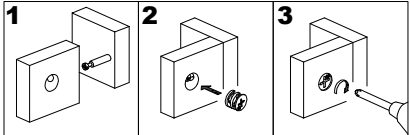

Using cam lock(D) secure part (15) to parts (16,18) with Philips head screwdriver as per diagram.

# Step 14

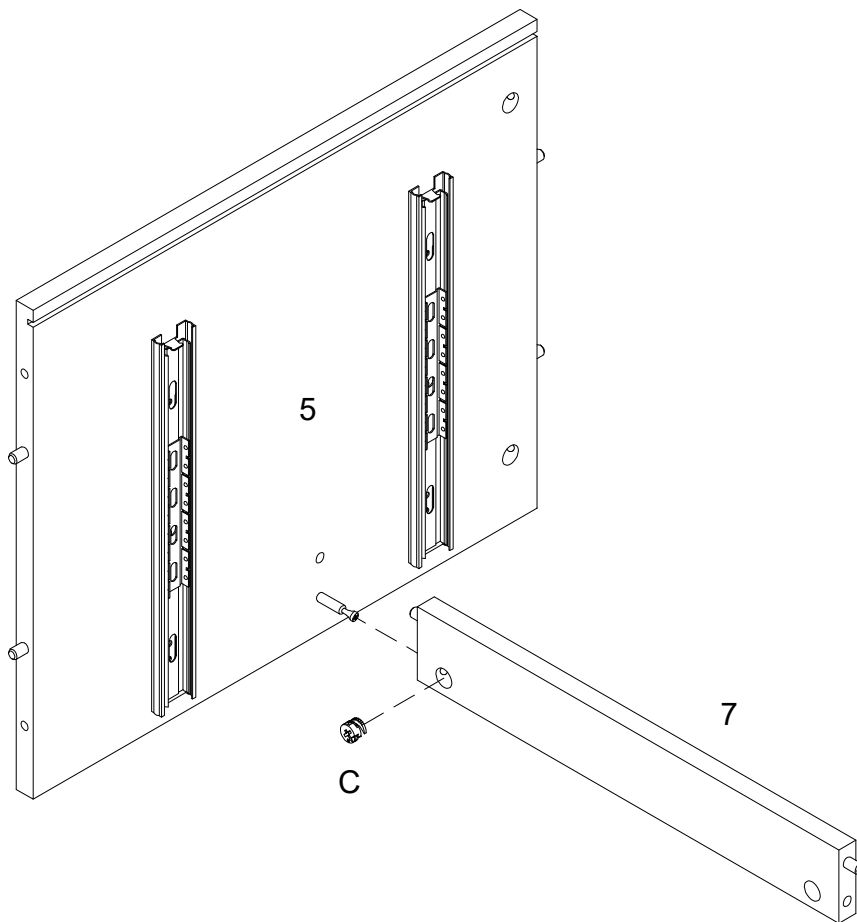
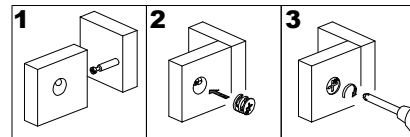

Using cam lock (C) secure part (7) into part (5) with Philips head screwdriver as per diagram.

# Step 15

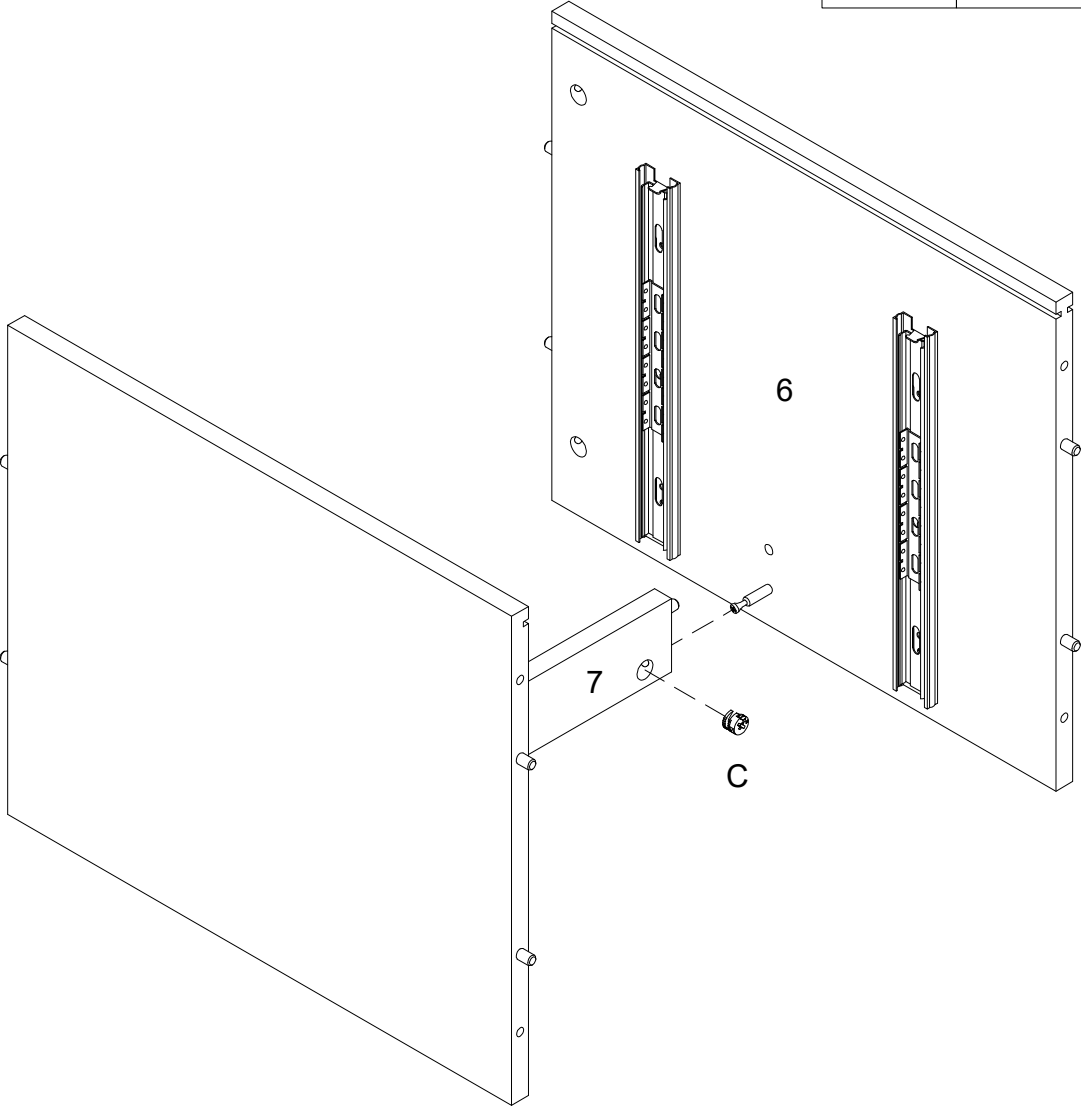
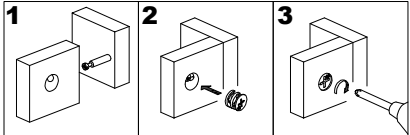

Using cam lock (C) secure part (7) into part (6) with Philips head screwdriver as per diagram.

# Step 16

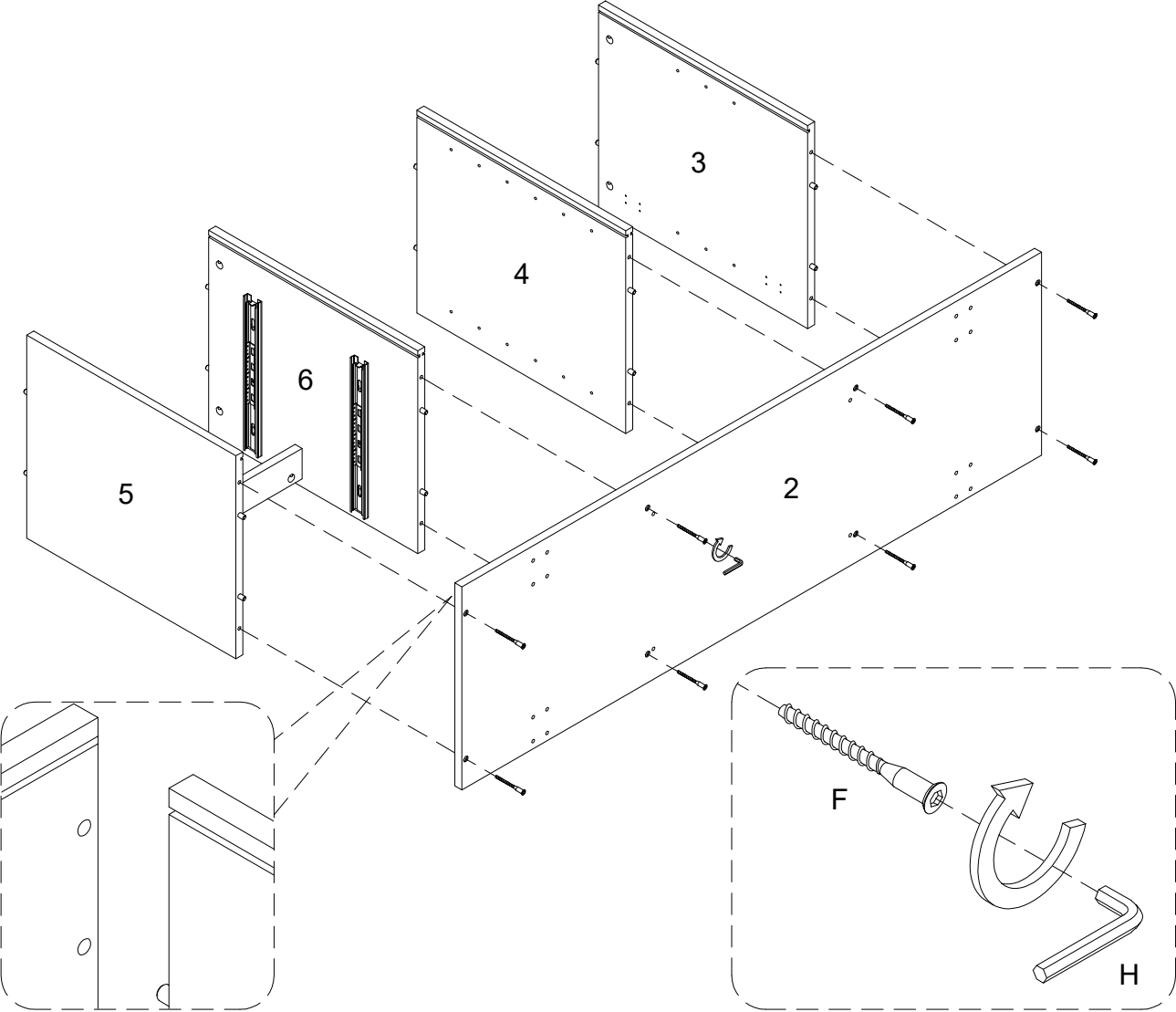

Using screw (F) attach part (2) into parts (3,4,5,6) with Hex Key (H) as per diagram.

# Step 17

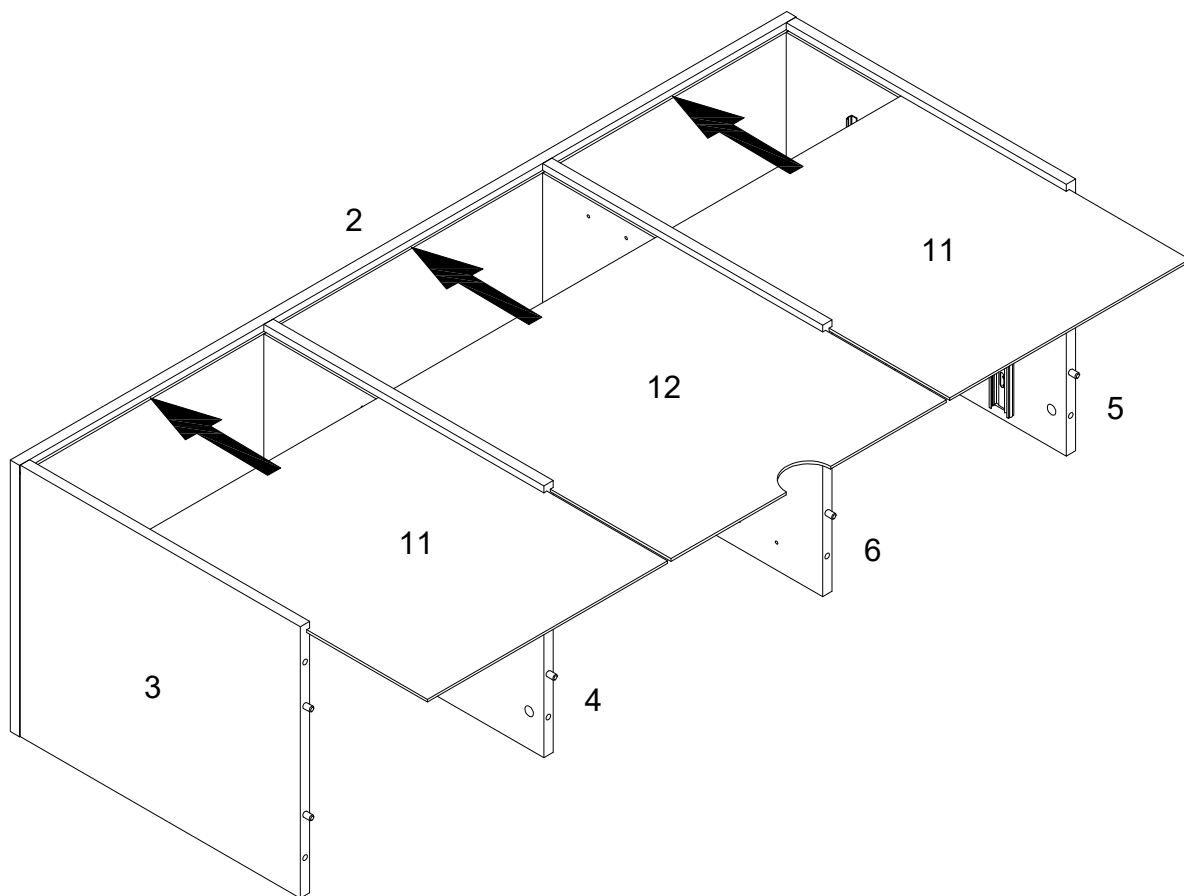

Put parts (11,12) as per diagram.

# Step 18

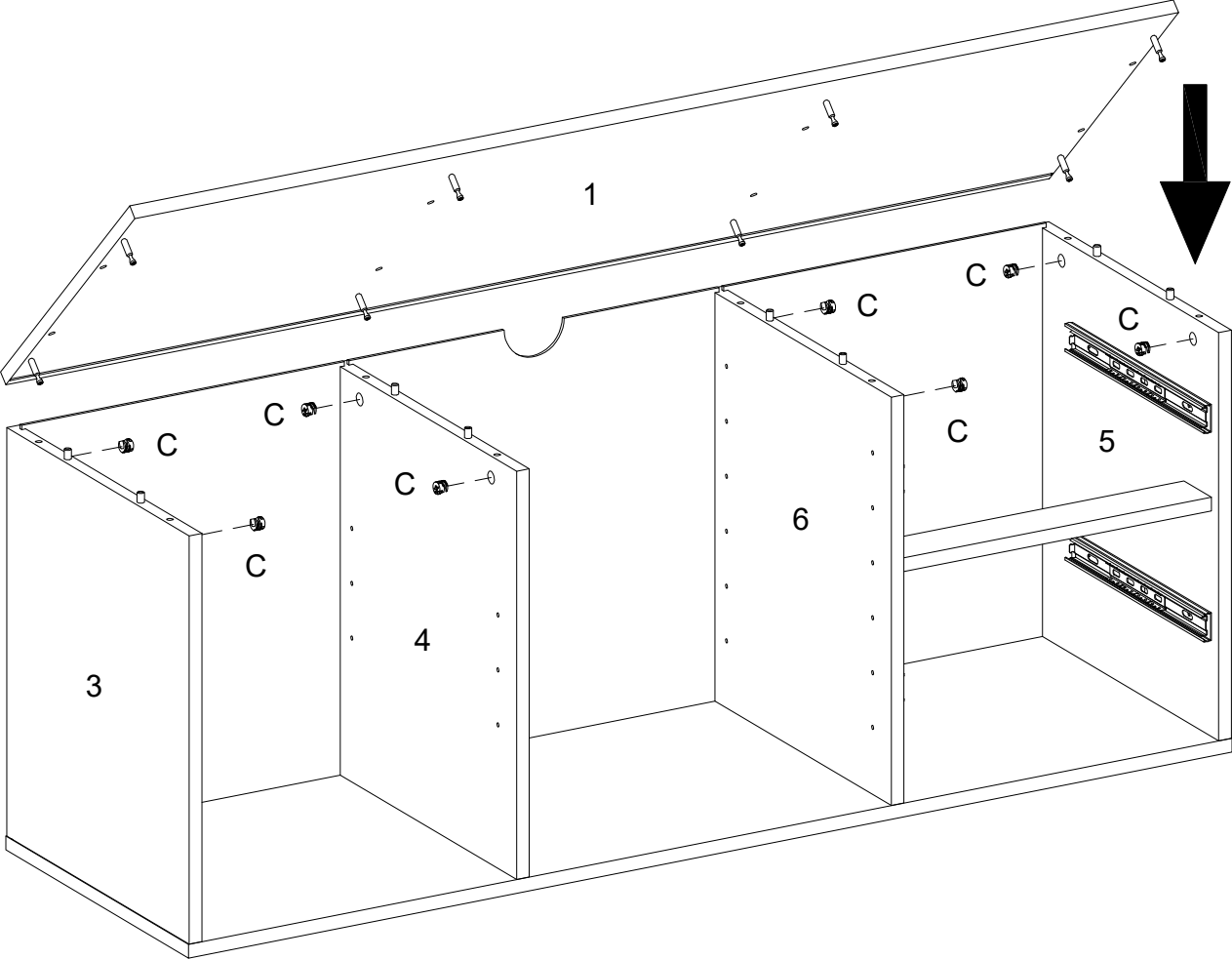
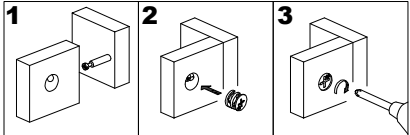

Using cam lock (C) secure part (1) to parts (3,4,5,6) with Philips head screwdriver as per diagram.

# Step 19

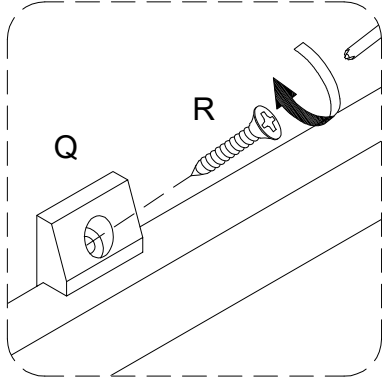
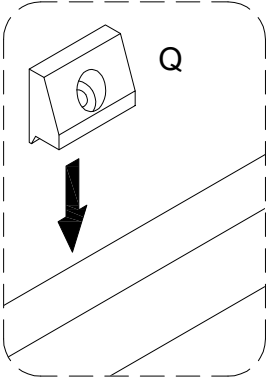
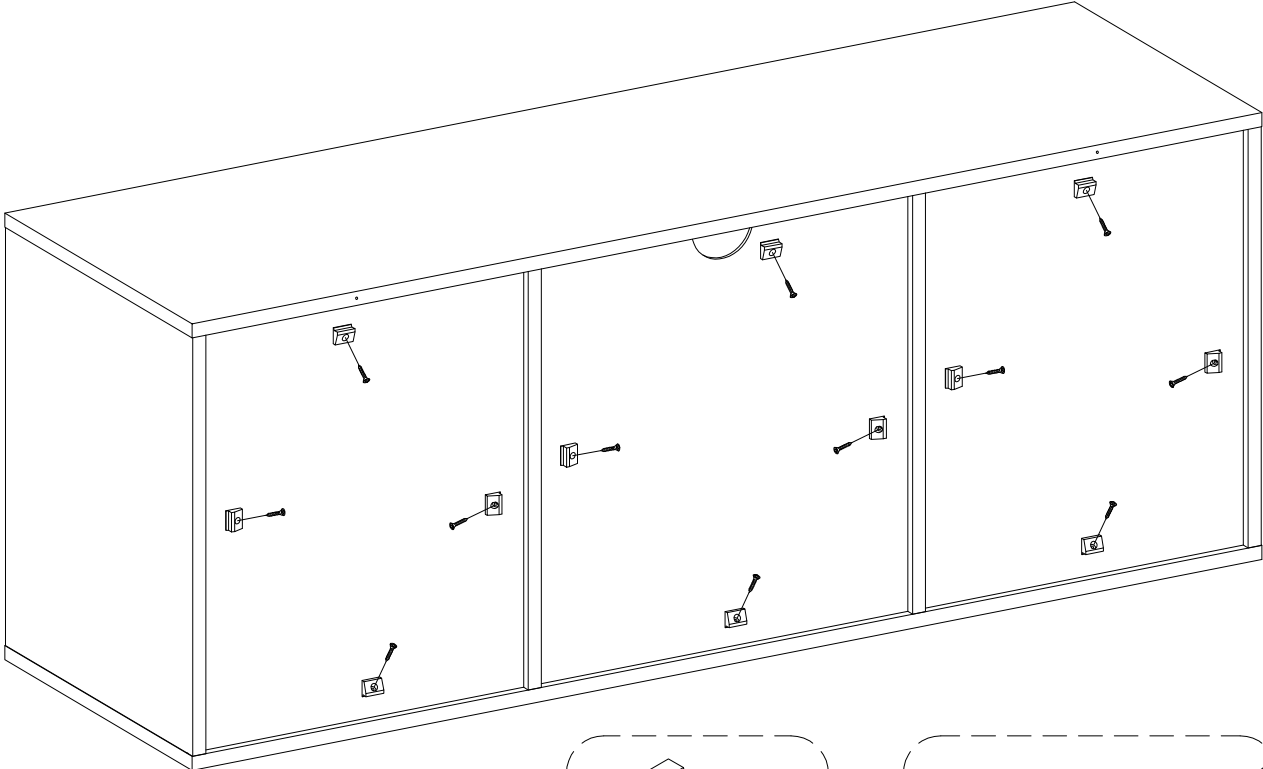

Using screw (R) secure plastic wedge (Q) with Philips head screwdriver as per diagram.

# Step 20

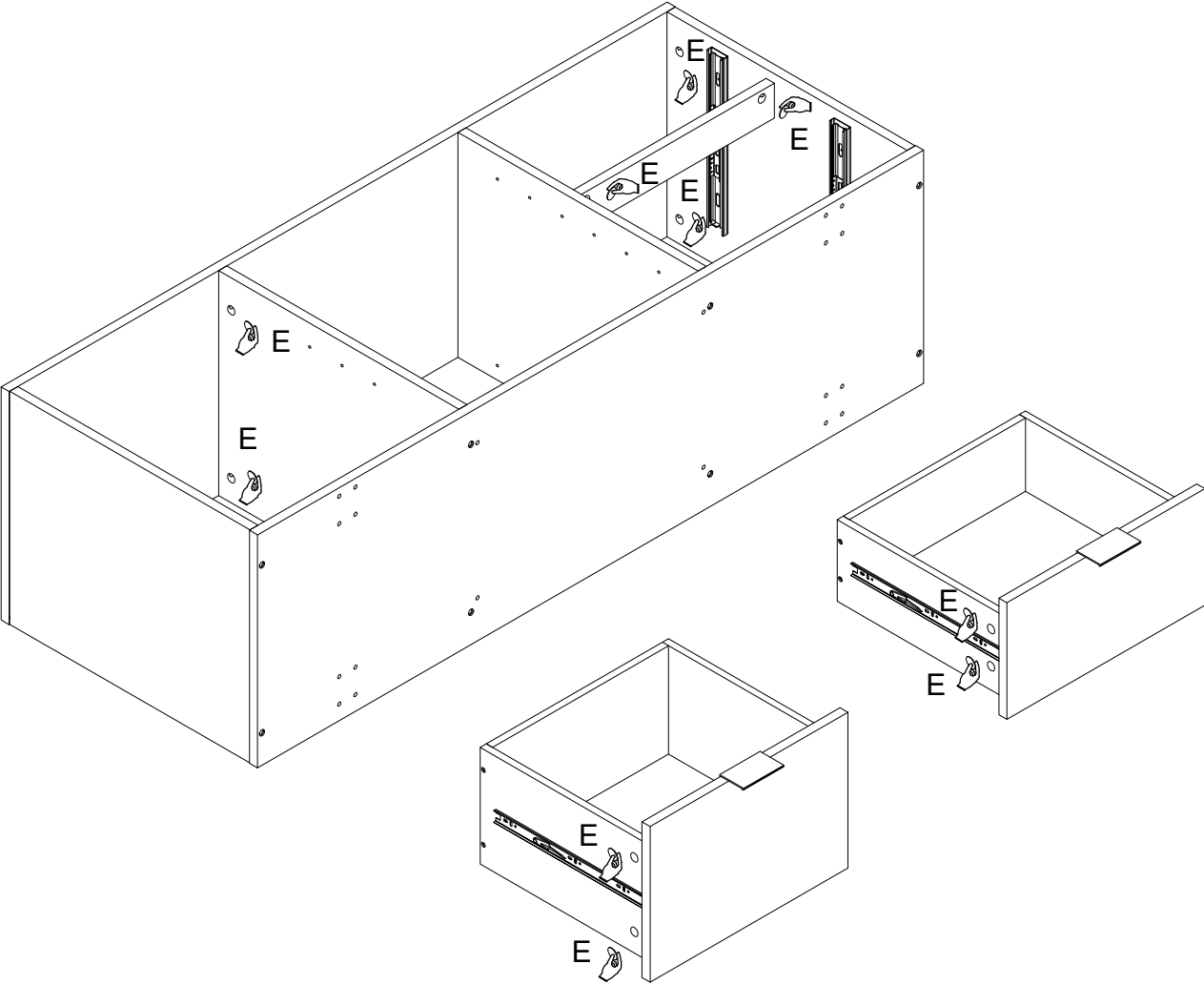

Place sticker (E) cover the holes as per diagram .

# Step 21

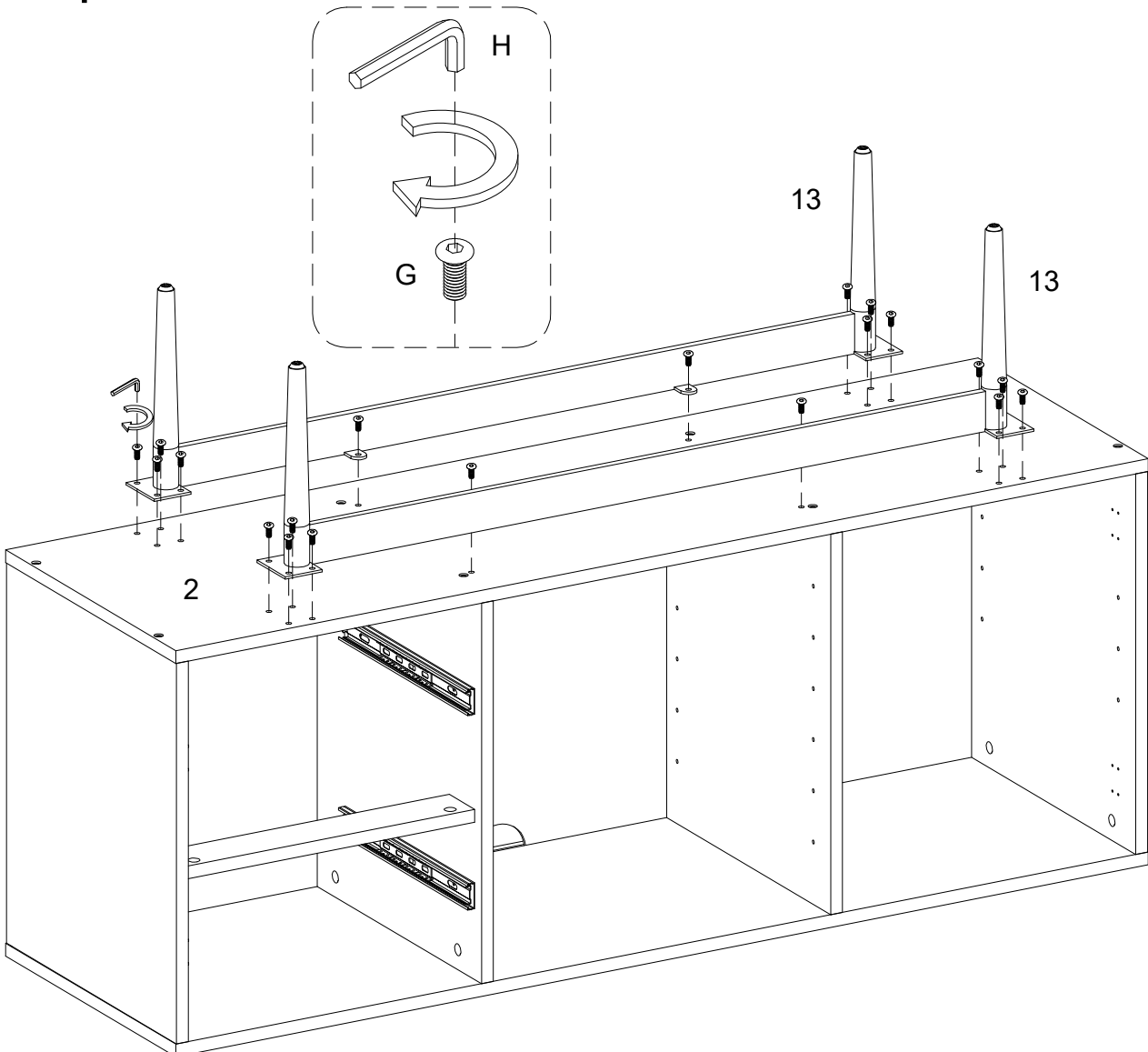

Using bolt (G) attach parts (13) to part (2) with hex key (H) as per diagram.

## Step 22

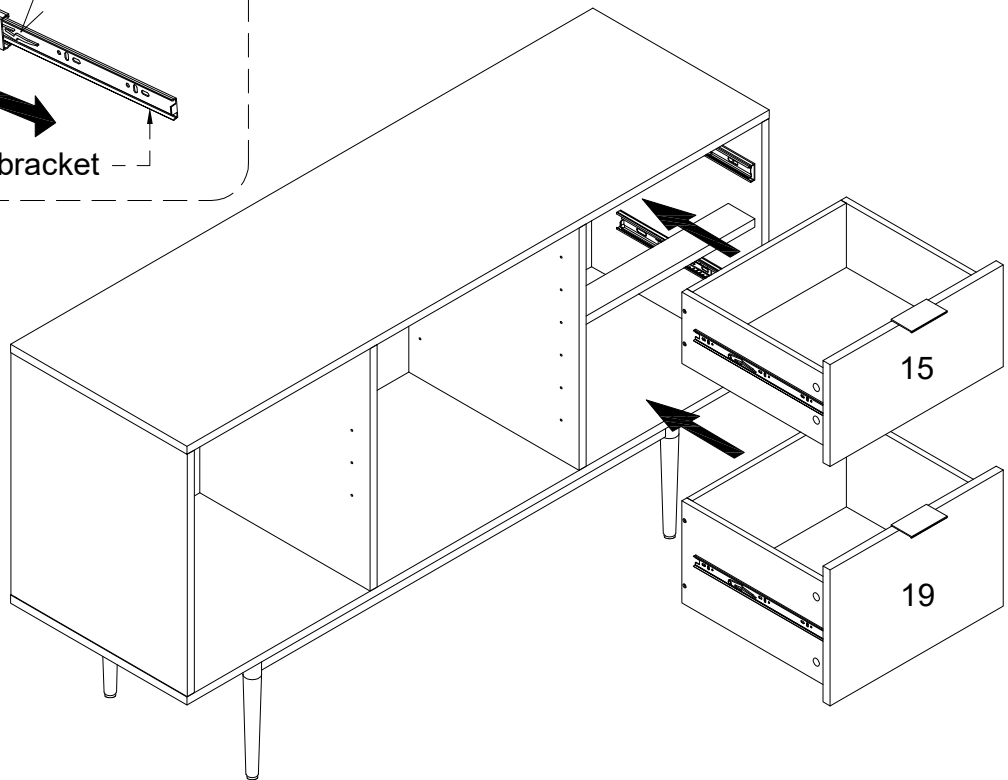
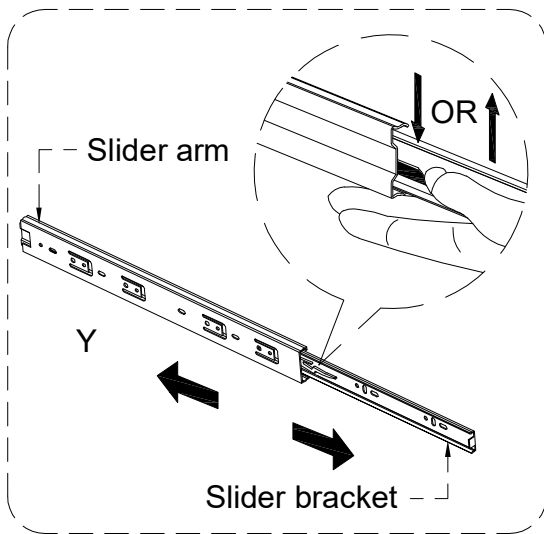

Assembled the drawers as per diagram

Note :If the drawer does not go in smoothly .Press or lift the plastic release lever .

Pull out the slider bracket from the slider arm then re-assembled the drawer until they were going in smoothly well .

# Step 23

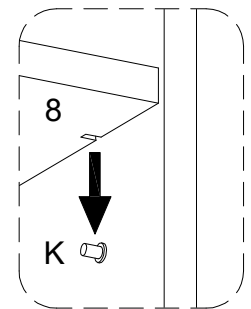
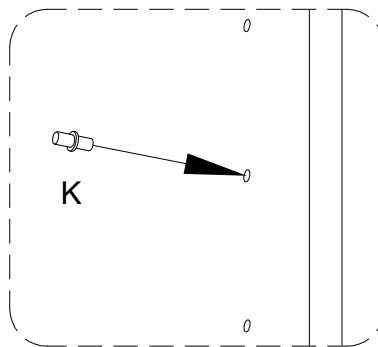
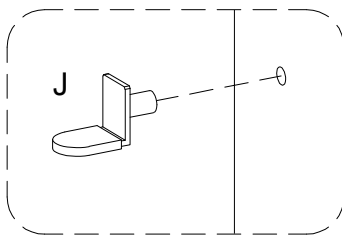
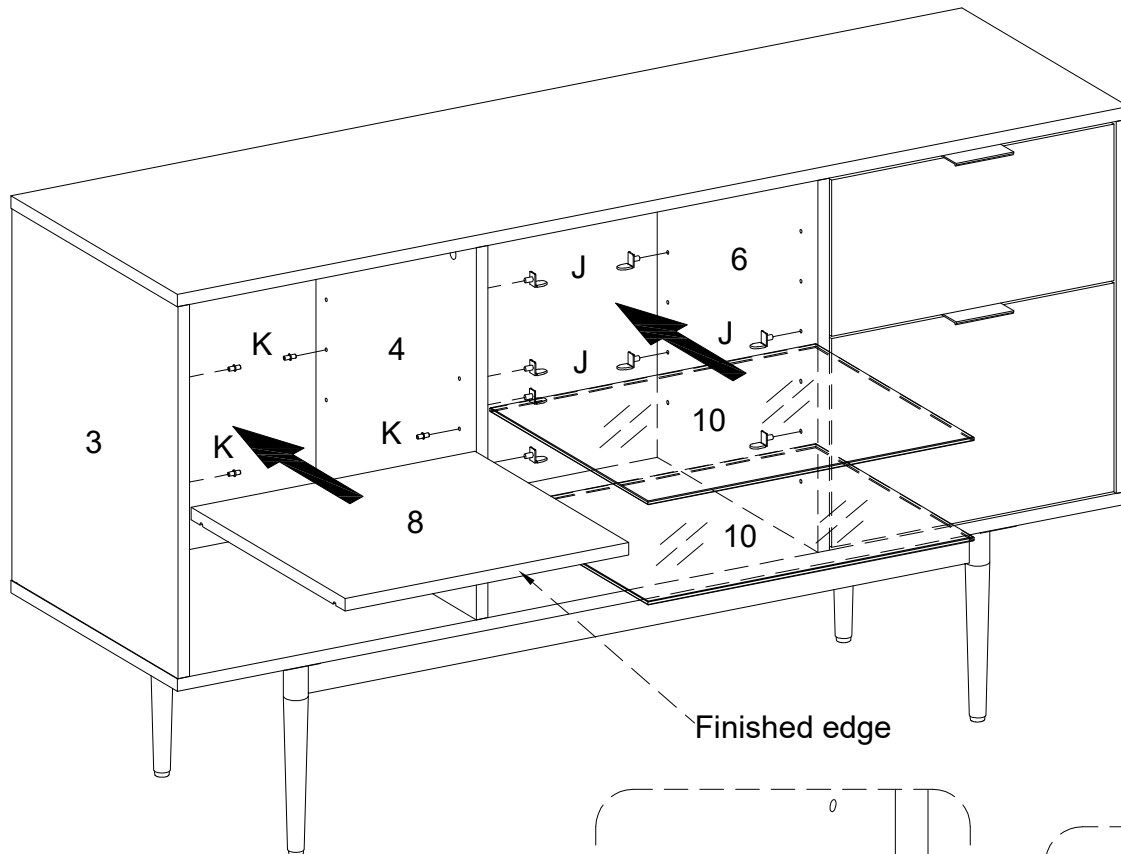

Insert shelf support pin (K) into parts (3,4) ,L shape shelf support pin (J) into parts (4,6) as per diagram. Make sure you place the four shelf support pins in the same level. So the shelf is not tilted .Put parts (8,10) into unit as per diagram. Tilt and rest the adjustable shelf(8,10) onto the shelf support pins .

# Step 24

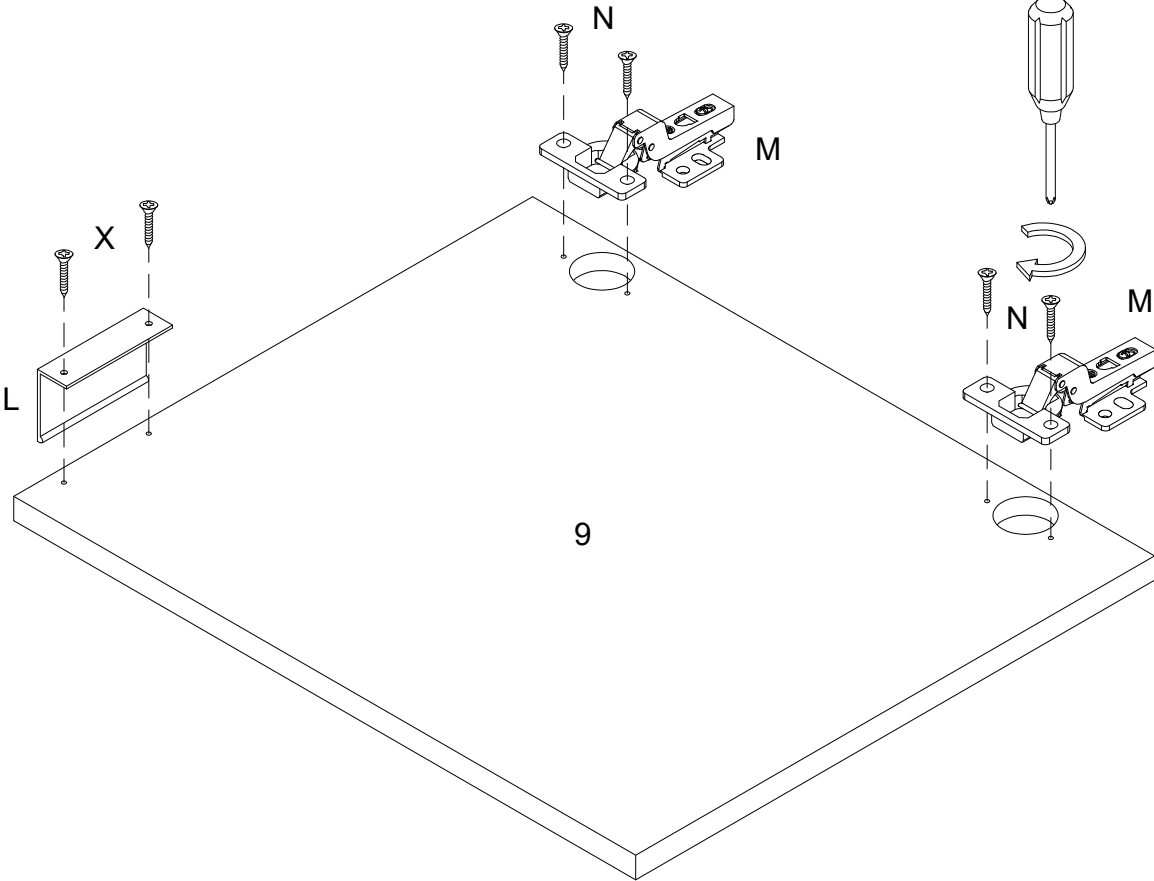

Using screw (N) attach Europe hinge (M) ,screw (X) attach Handle (L) to part (9) with Philips head screwdriver as per diagram.

# Step 25

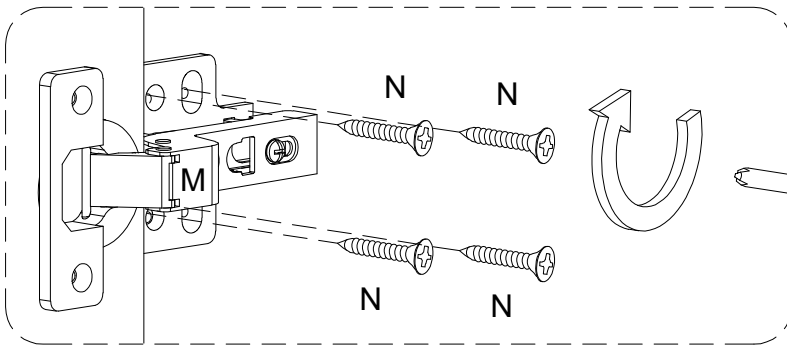
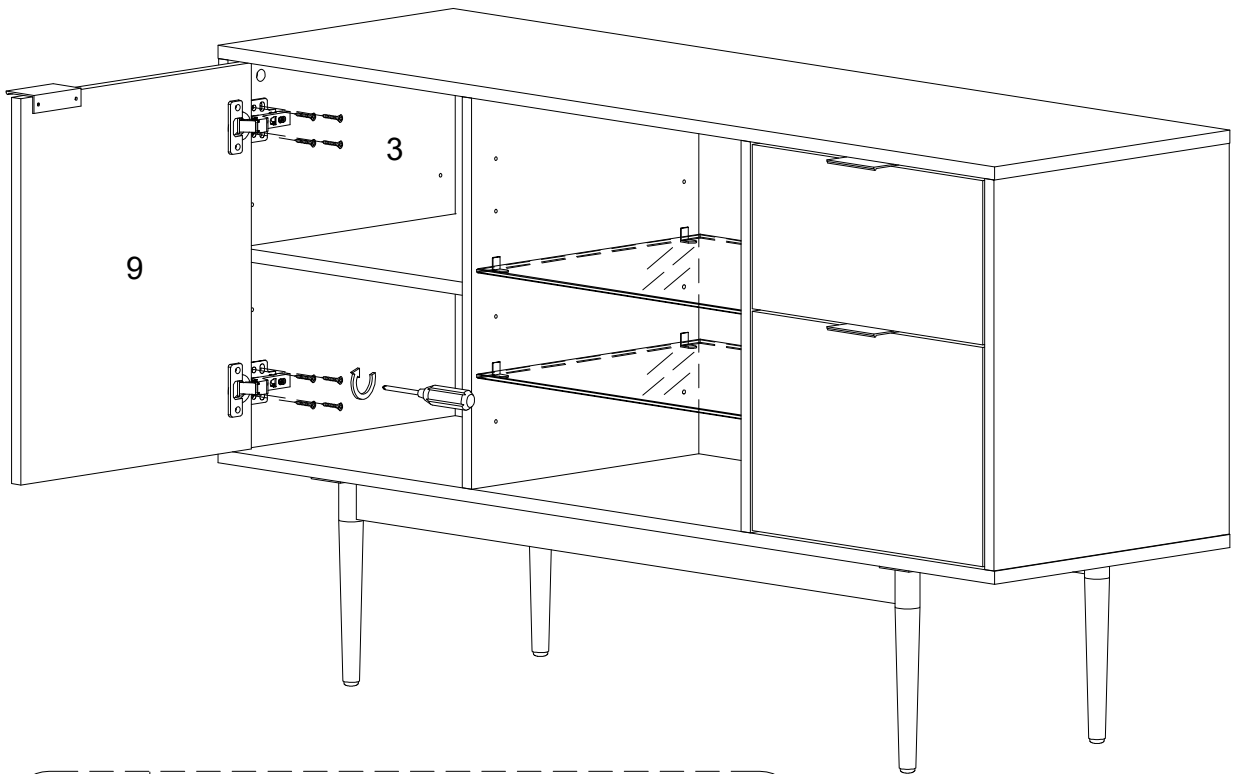

Using screw (N) attach Europe hinge (M) into part (3) with Philips head screwdriver as per diagram. Close and open the door .If necessary ,adjust the screws for a good fit .

# Step 26

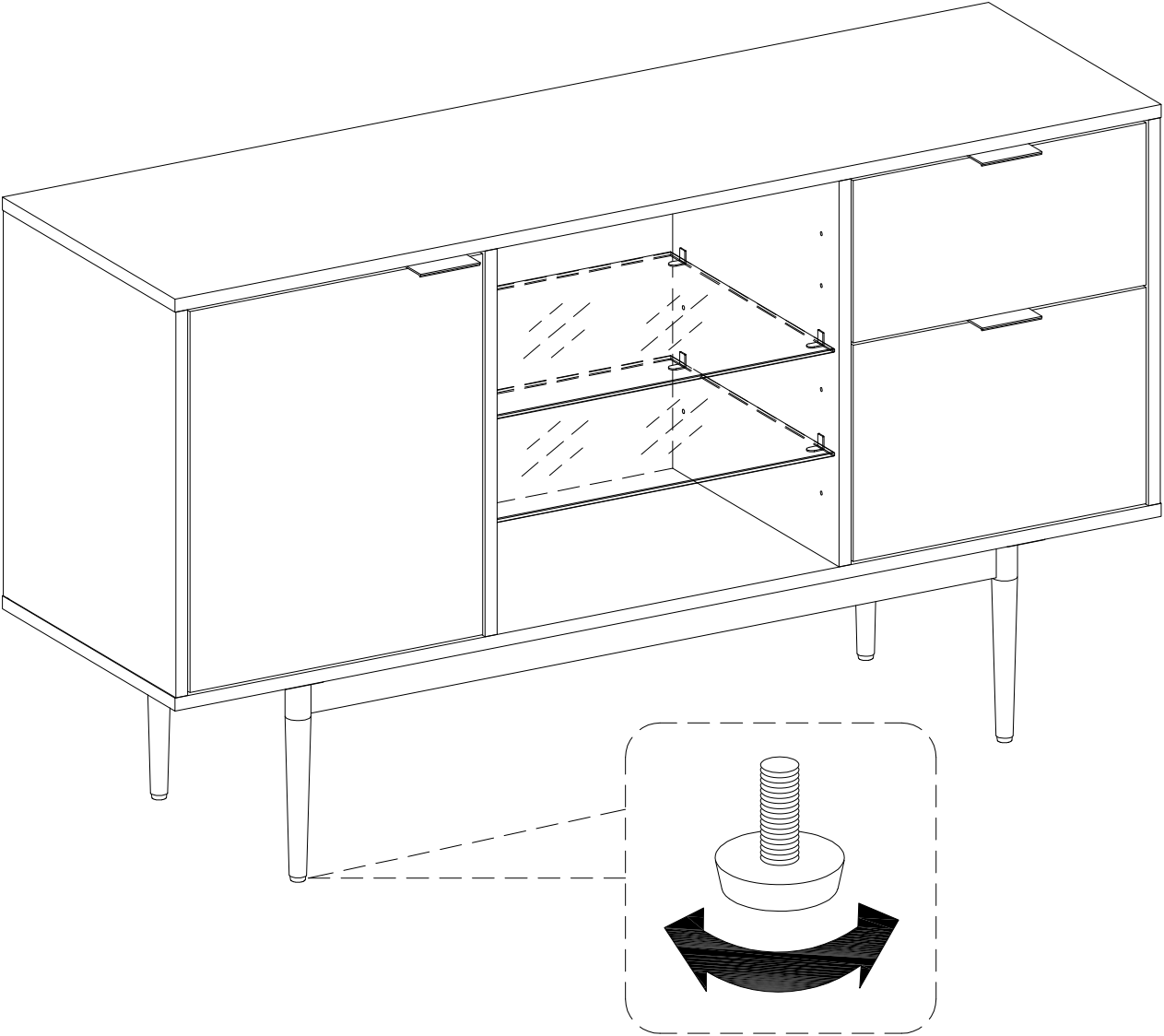

Position the assembled unit at the desired location ,if necessary adjust the floor leveler at the bottom of the legs to level the unit .

# Step 27

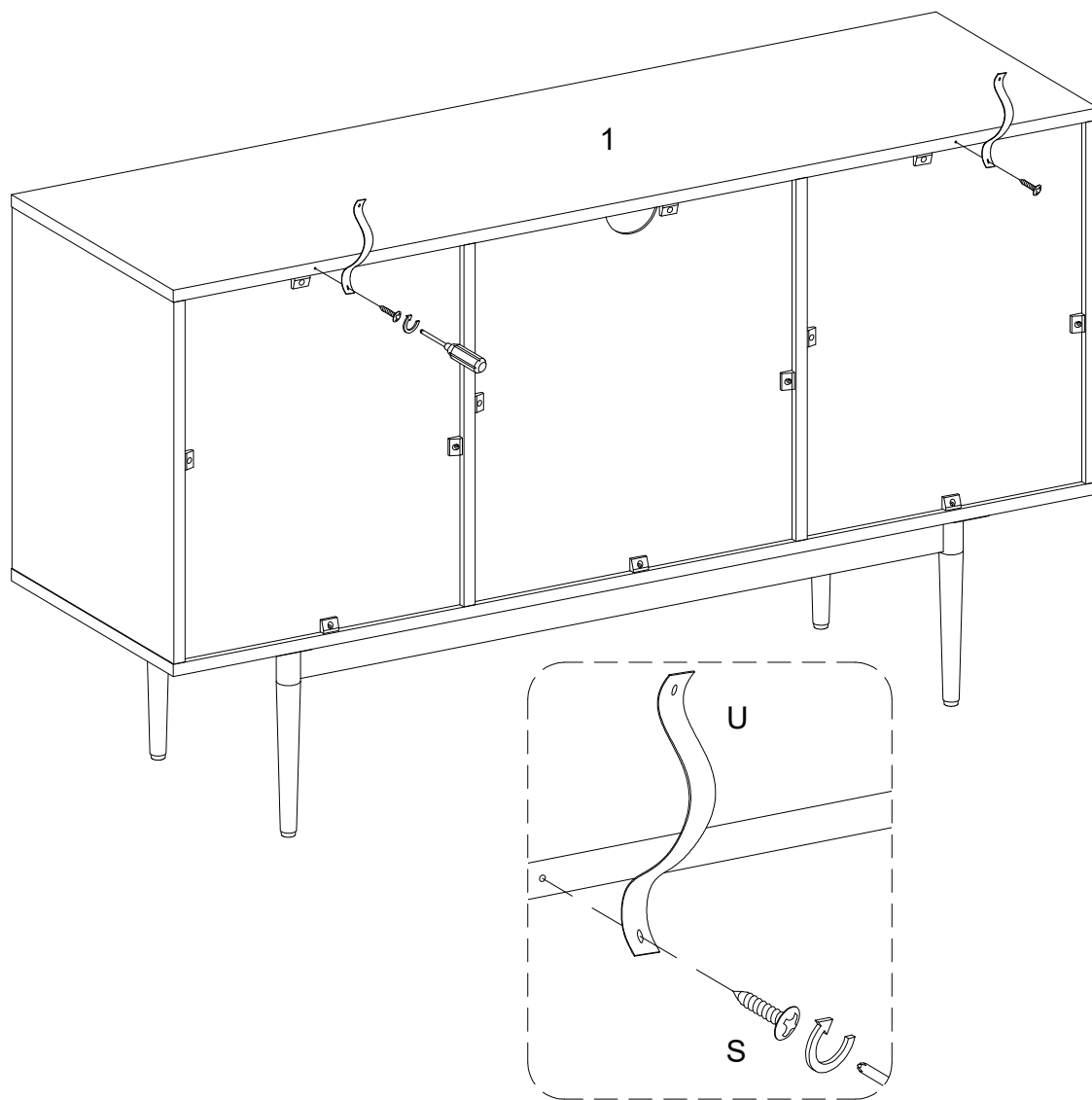

Using screw (S) attach Velcro strap (U) into part (1) with Philips head screwdriver as per diagram.

# Step 28

## WARNING

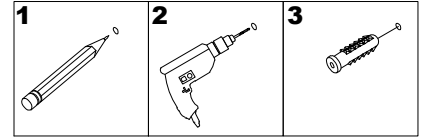

Serious or fatal injuries can occur from furniture tipping over. To prevent the furniture from tipping over we recommend that it is permanently fixed to the wall. Wall anchor and hardware are included with this product. Please make sure hardware is suitable for your walls before installing, as different wall materials may require different types of anchors.

Wall

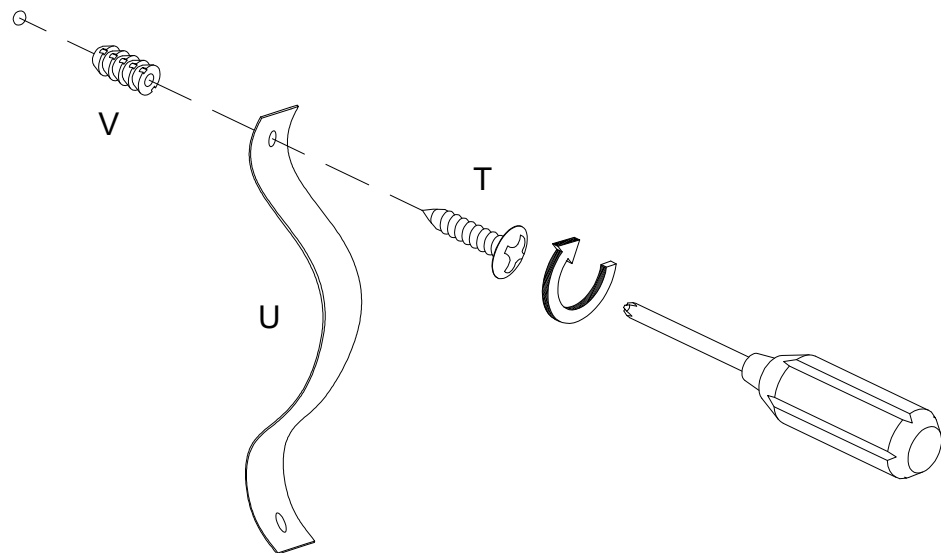

(EN)

Using screw (T) attach plastic strap (U) into nut (V) to wall with Philips head screwdriver as per diagram.

# Step 29

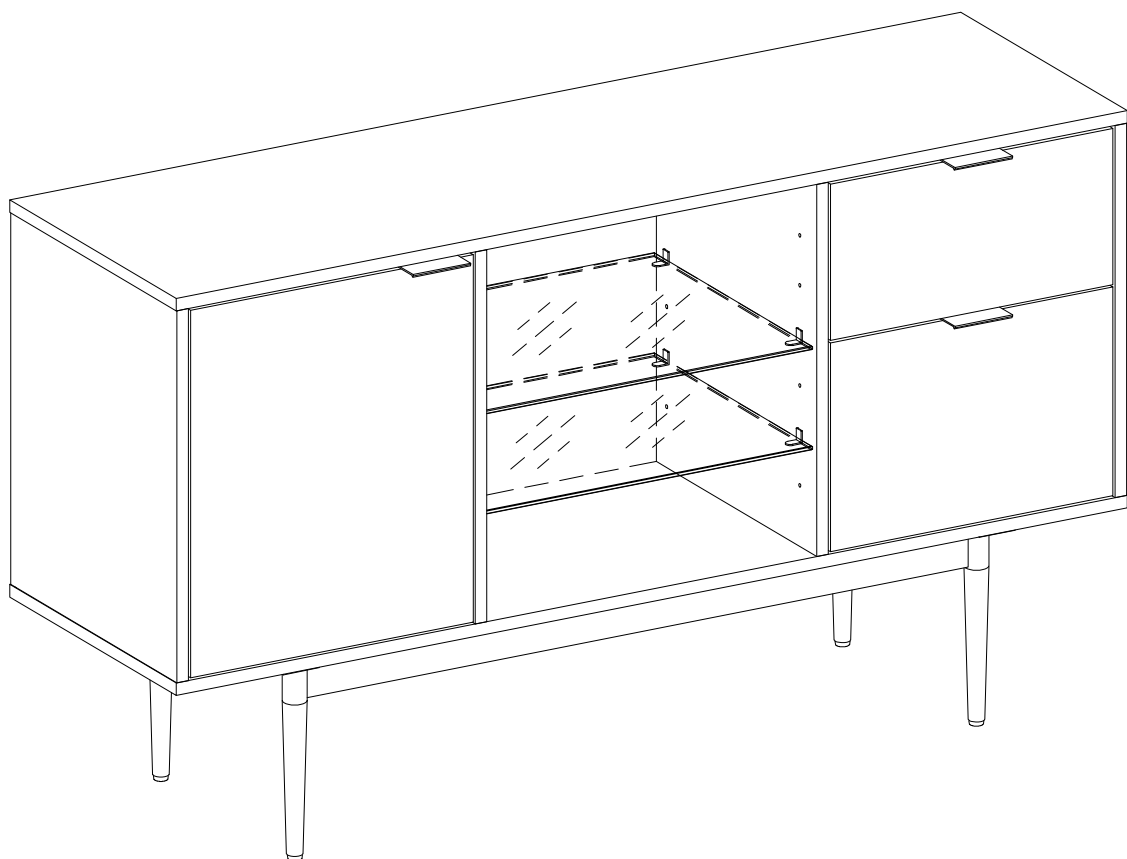

## Final Assembly