

Assembly Instructions

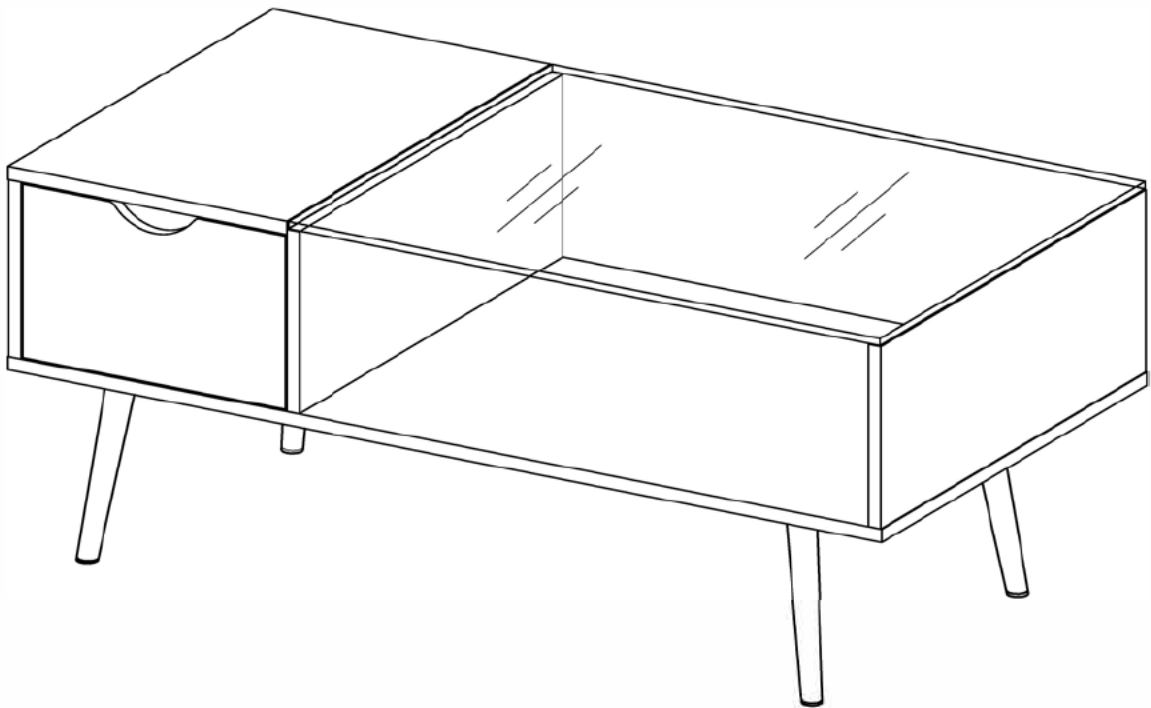

Revised 12/2017

General Assembly Guidelines

- I. Ensure that all parts and hardware are available before beginning assembly.
- II. Follow each step carefully to ensure the proper assembly of this product.
- III. Two people are recommended for ease in the assembly of this product.
- IV. The three main types of hardware used to assemble this product are : wood dowels , screws and bolts.
- V. The provided glue is to secure wood dowels in place . When first inserting dowels , locate the appropriate hole for the dowel , place a small amount of glue in the hole and insert the dowel . Wipe away excess glue immediately.

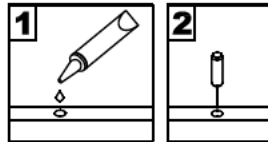

In future assembly steps when dowels are necessary to attach assembly parts together , place a small amount of glue on the end of the dowel before attaching parts together . Wipe away excess glue immediately.

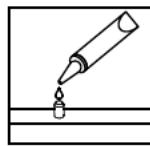

- VI. A Phillips head screwdriver is required for the assembly of this product .

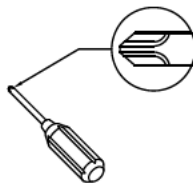



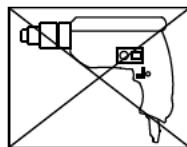



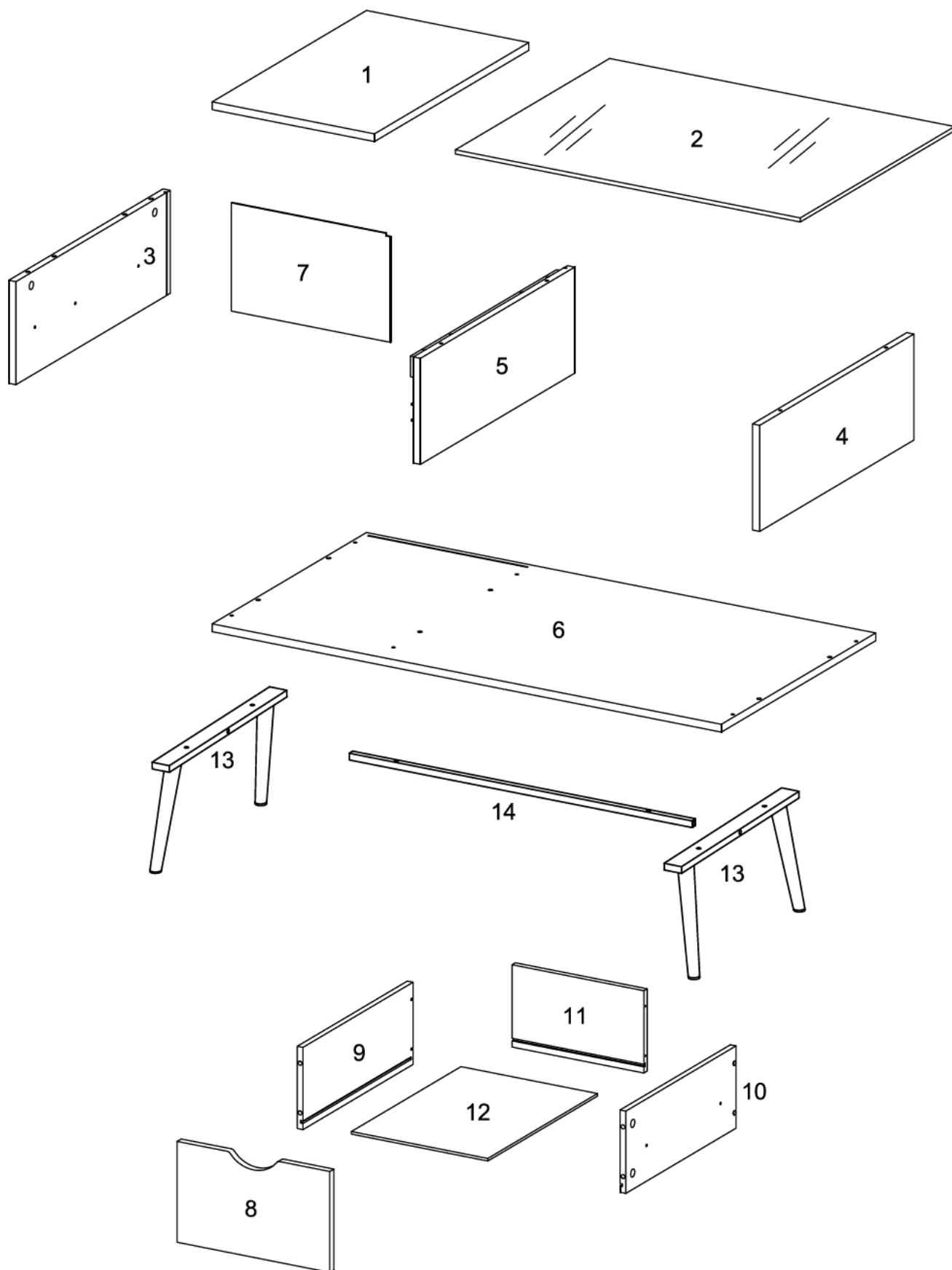



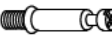



- VII. Power tools should not be used to assemble this product .

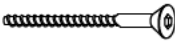
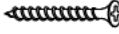

Parts List

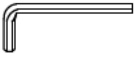
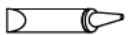

Hardware List

A		Ø8x30mm	Wooden dowel	10 pcs
B		Ø6x35mm	Cam bolt	8 pcs
C		Ø15x11mm	Cam lock	4 pcs
D		Ø15x9.5mm	Cam lock	4 pcs
E		Ø6x60	Bolt	2 pcs
F		Ø6x24	Bolt	6 pcs
G			Washer	6 pcs
H		Ø6x50mm	Bolt	6 pcs
J		Ø4x32mm	Screw	4 pcs
K		Ø3x17mm	Screw	4 pcs
L			Plastic wedges	4 pcs
M		Ø30	Sticker	8 pcs
N		Ø4mm	Wrench	1 pc
P			Glue tube	1 pc
Q			Rubber suction cups	4 pcs
R		Ø3x12mm	Screw	10 pcs
S			Drawer slider	1 sets

* Note: This piece comes preassembled for shipping purposes and must be disassembled to complete assembly.

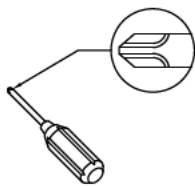

Philips head screwdriver required for assembly
(not included)

*The hardware quantities listed above are required for proper assembly.
Some extra hardware may also have been included.*

Step 1

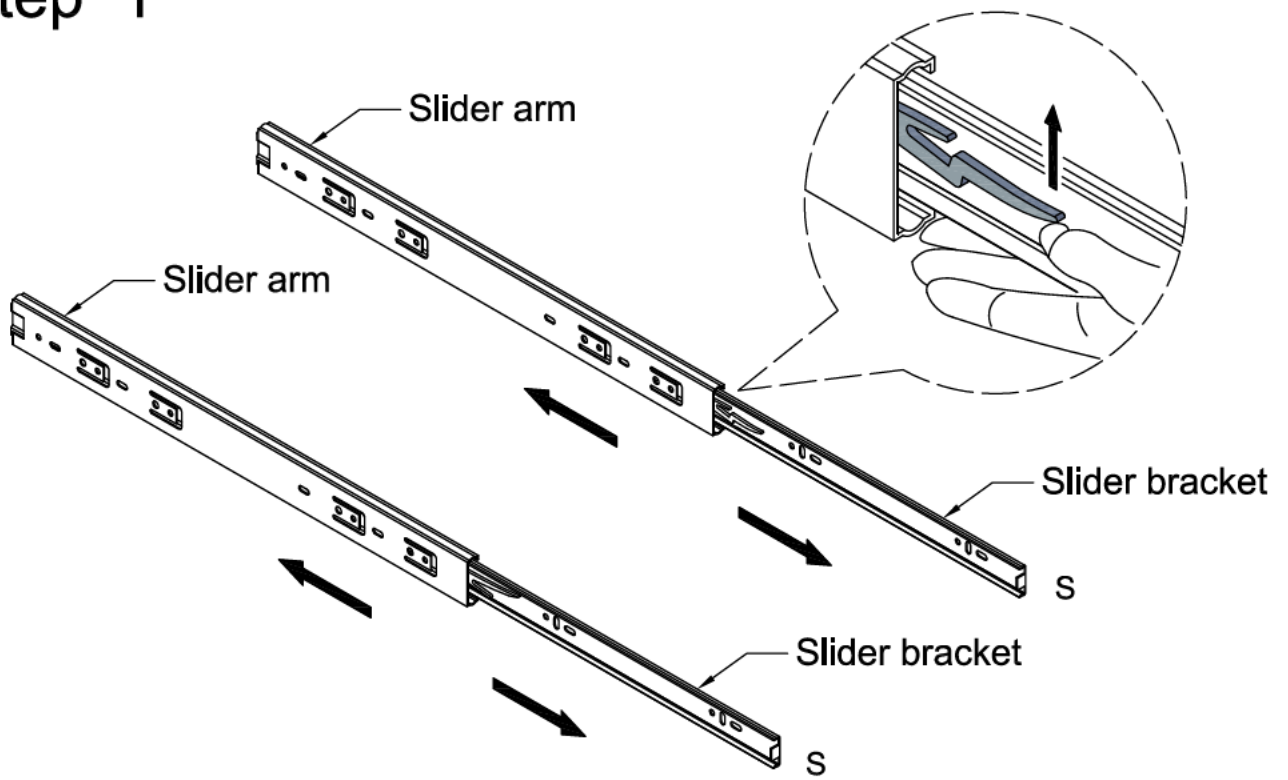

Step 2

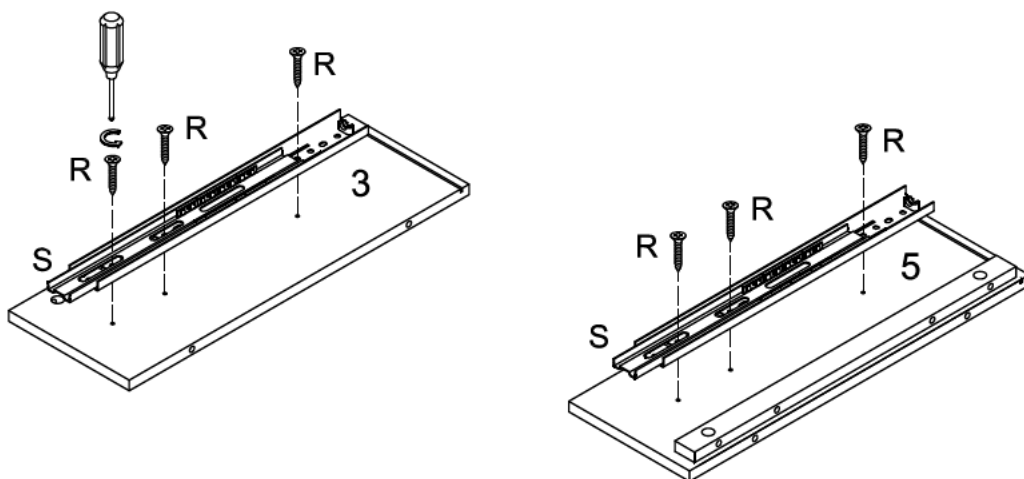

Step 3

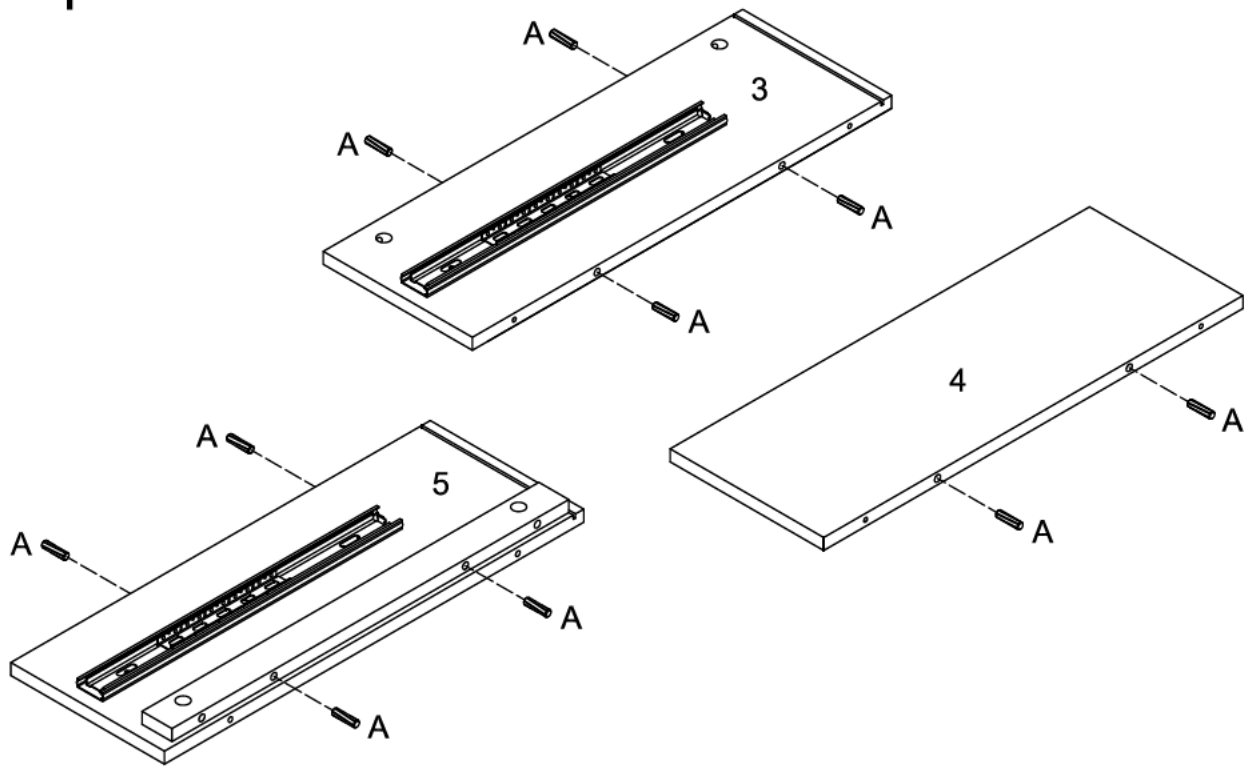

Step 4

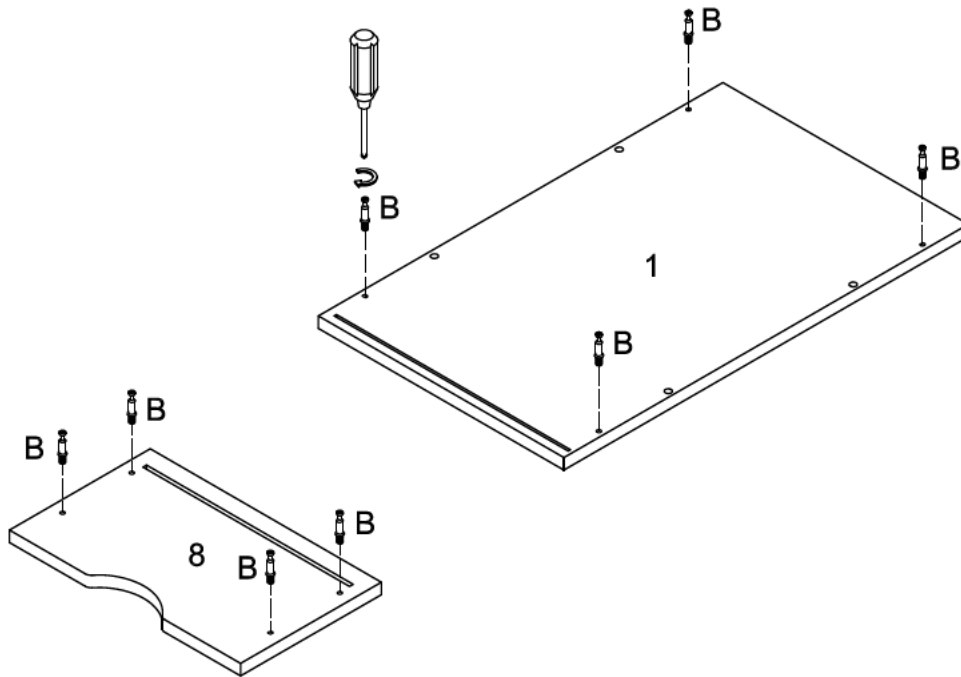

Step 5

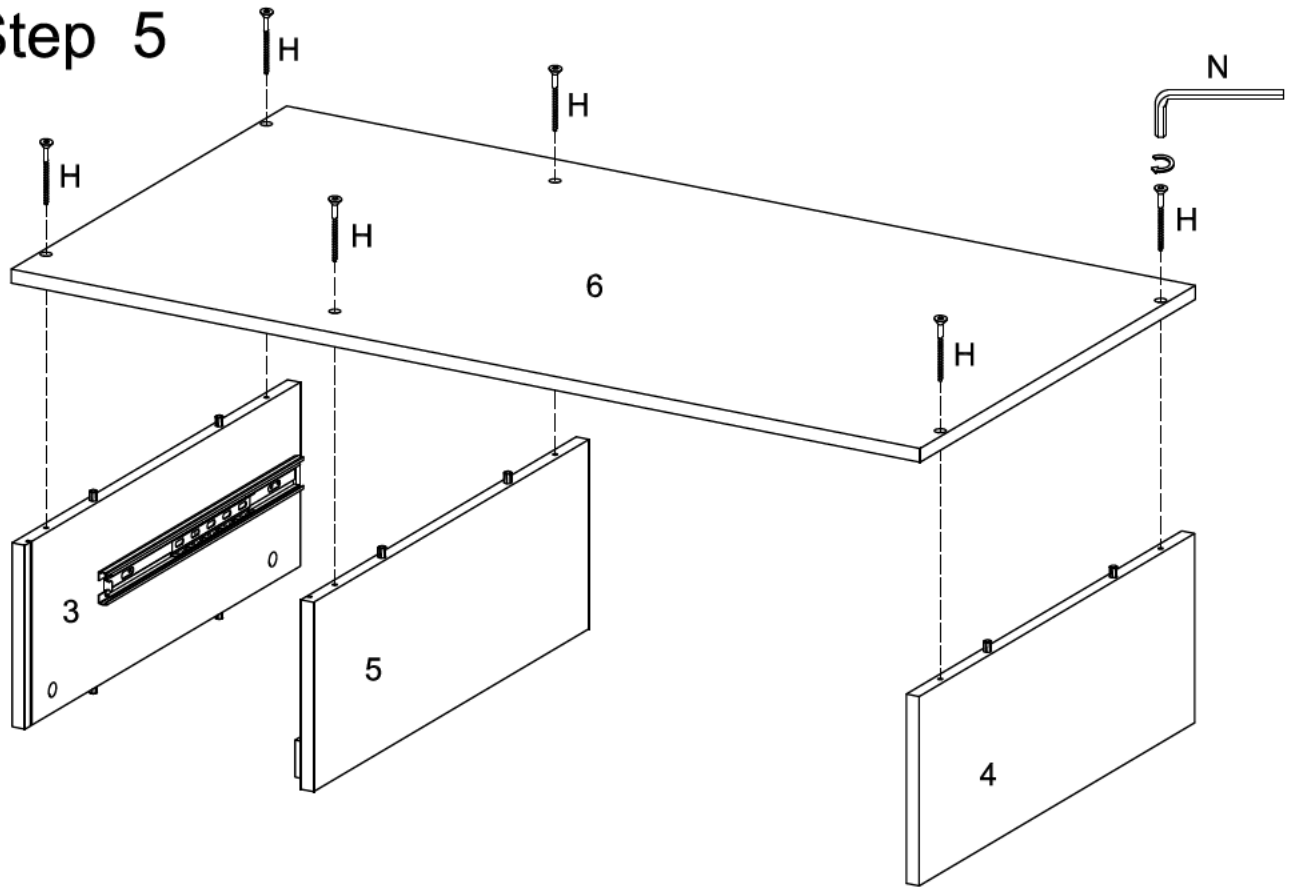

Step 6

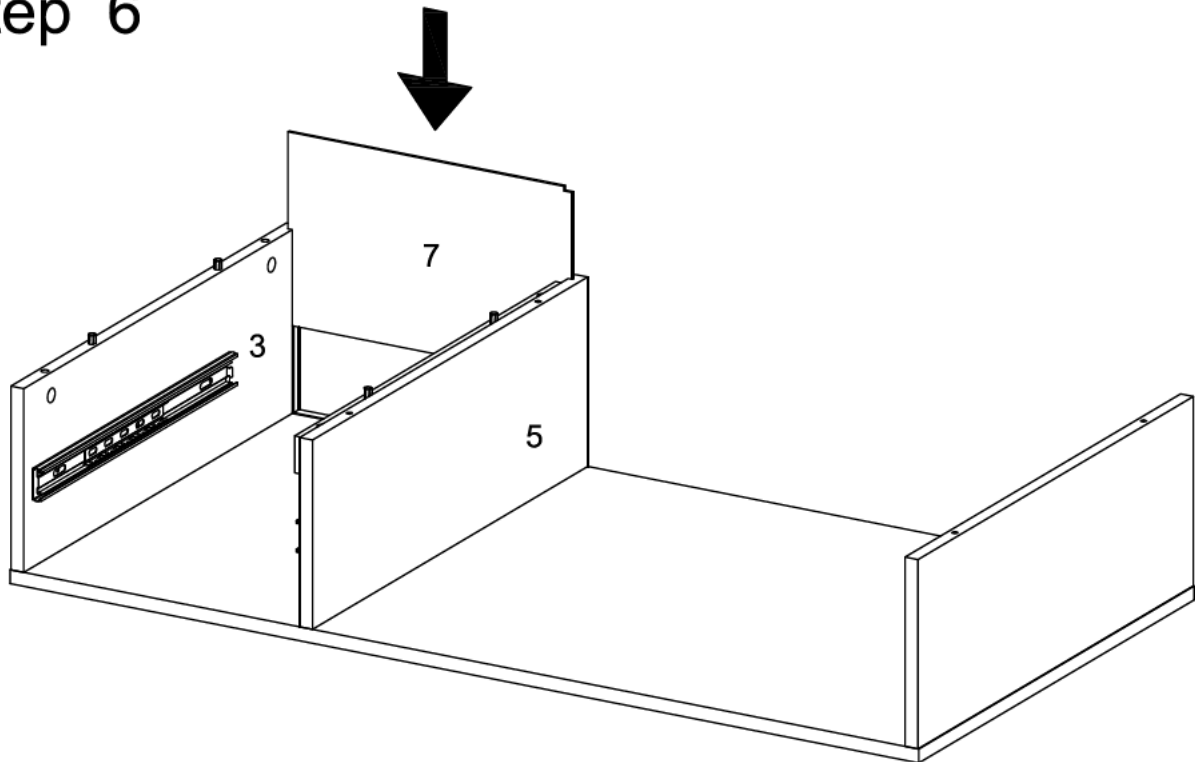

Step 7

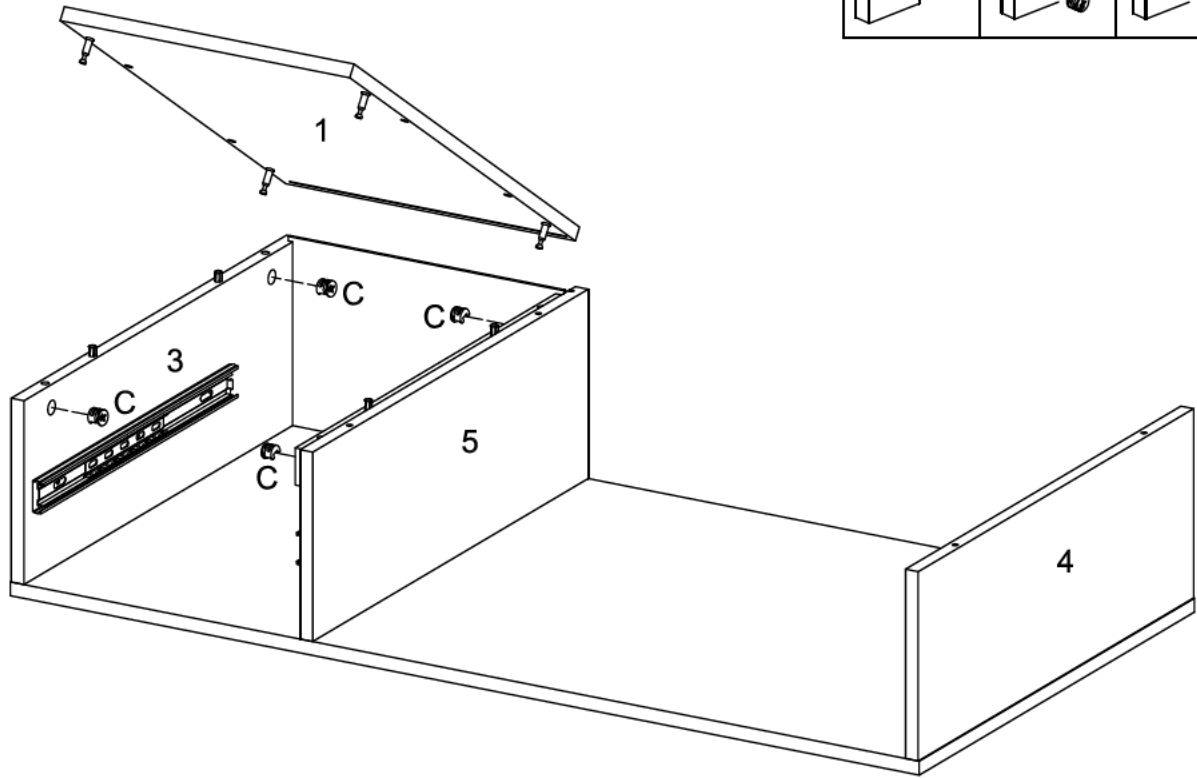
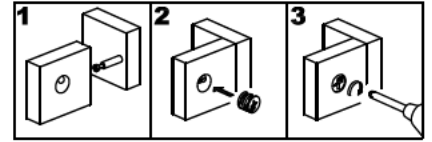

Step 8

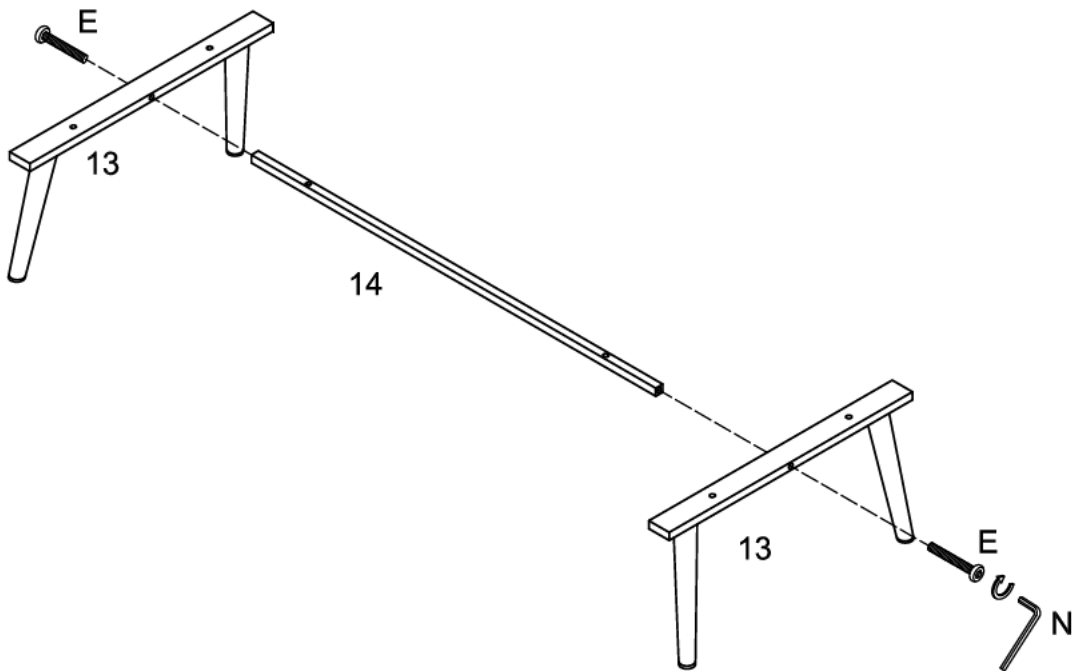

Step 9

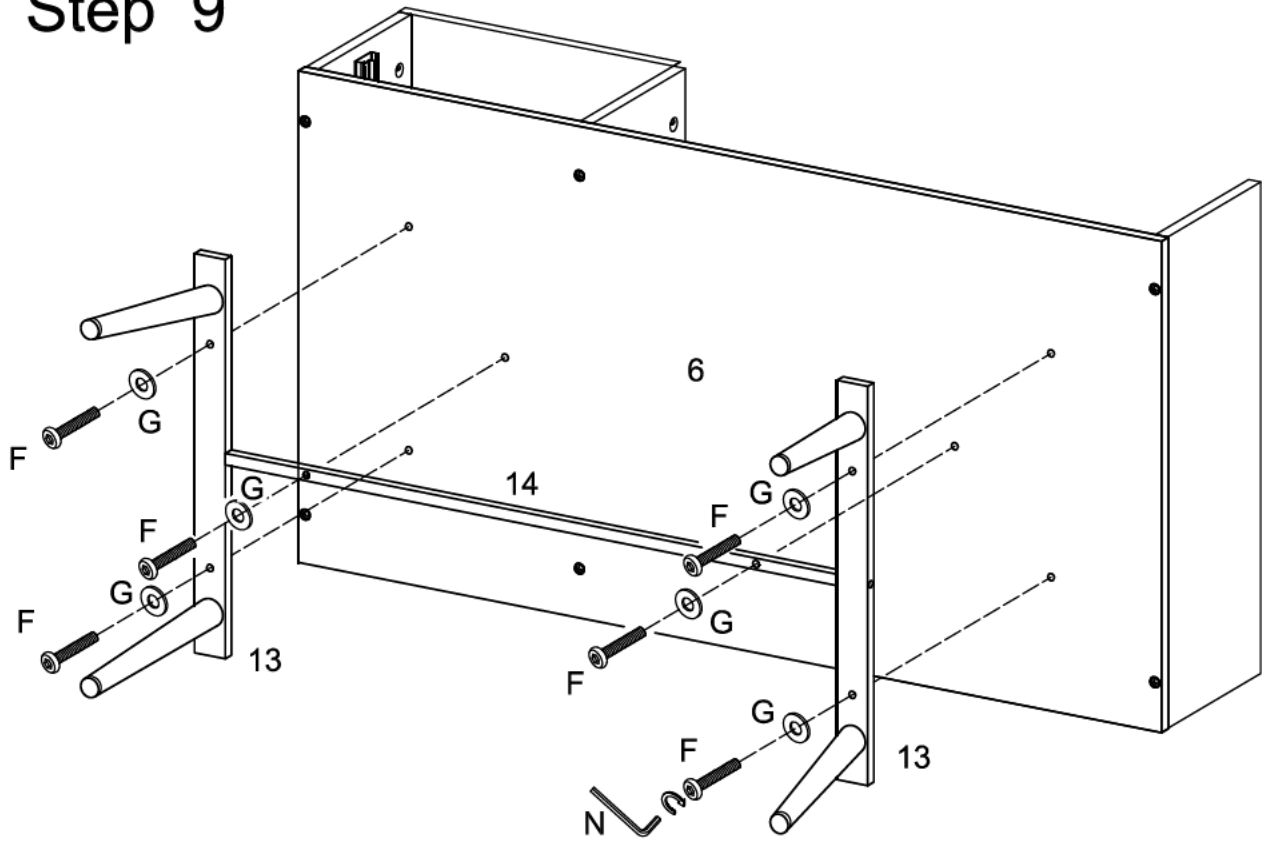

Step 10

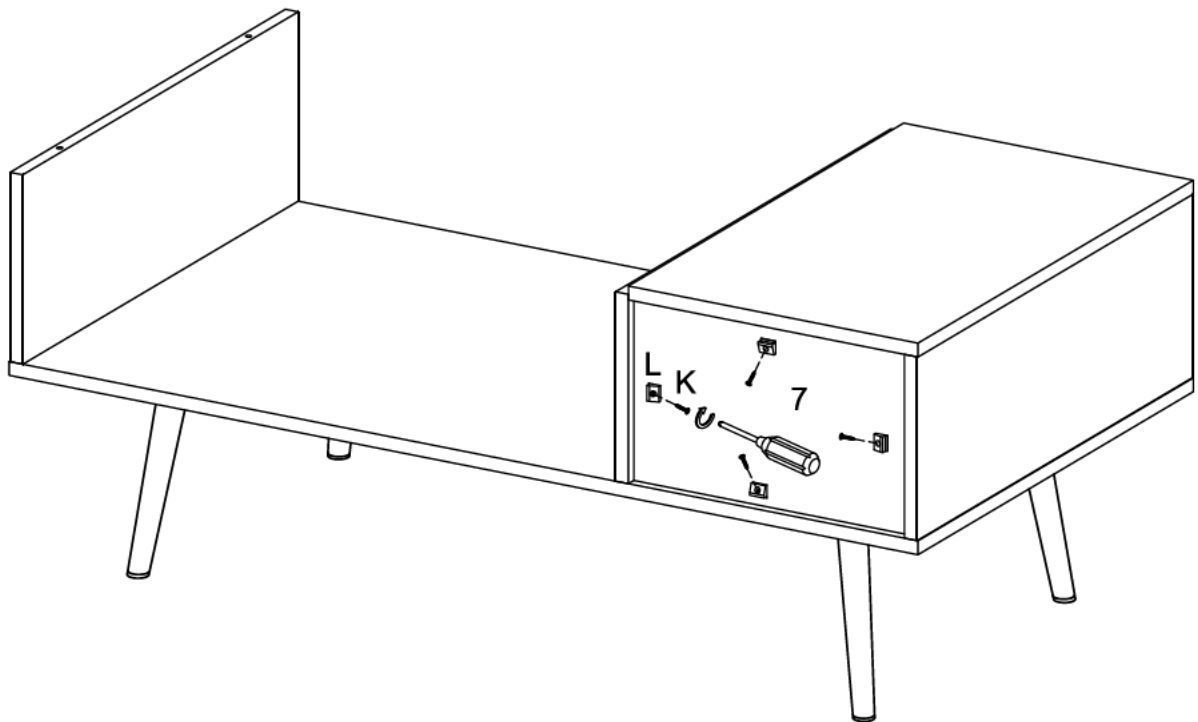

Step 11

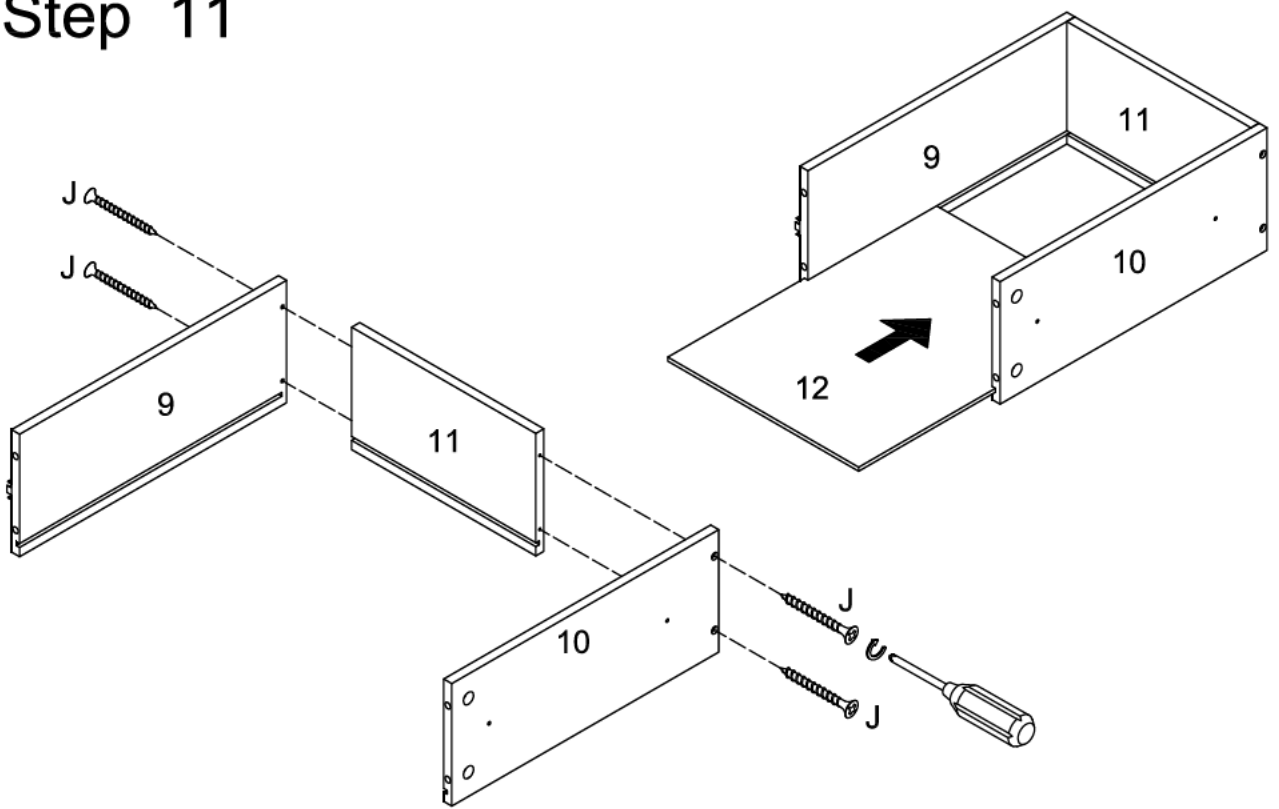

Step 12

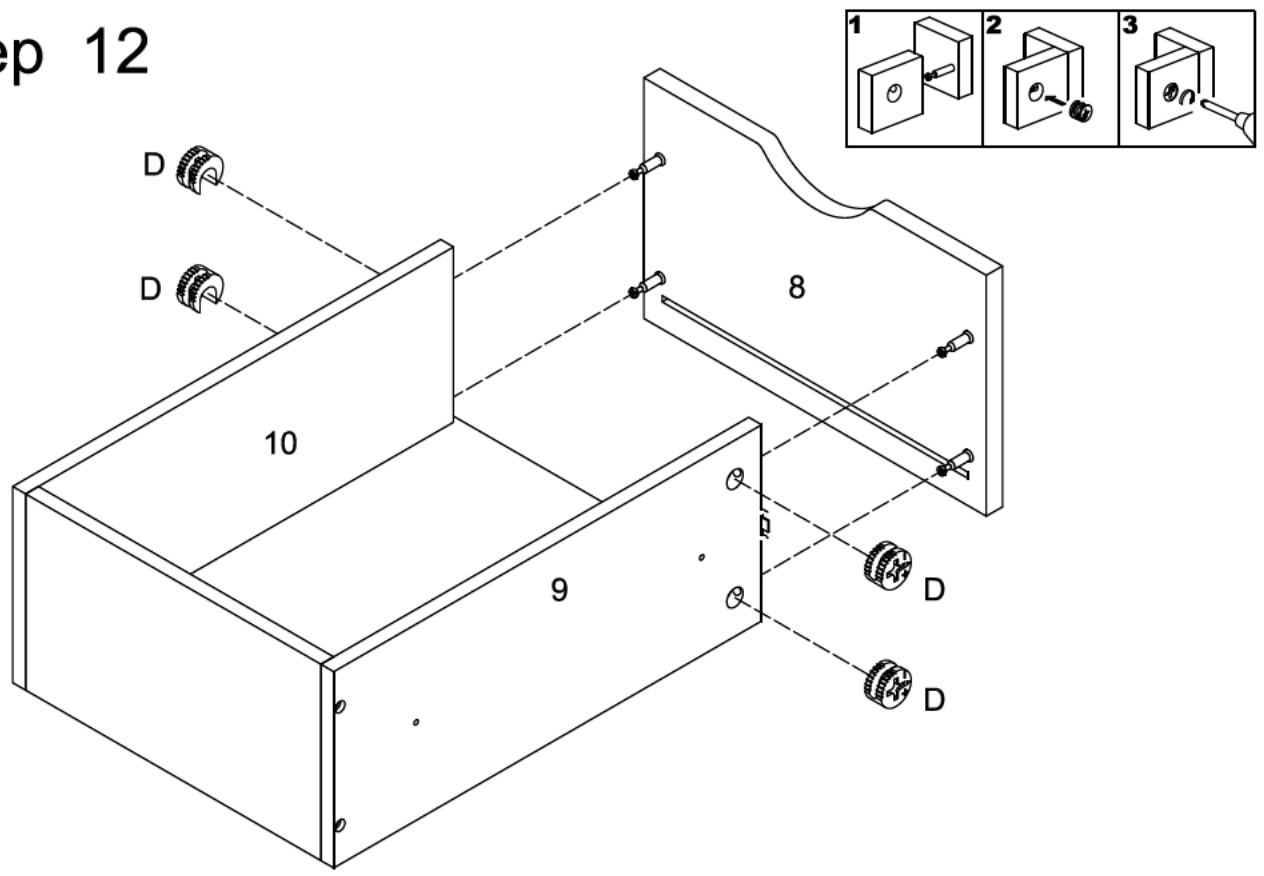

Step 13

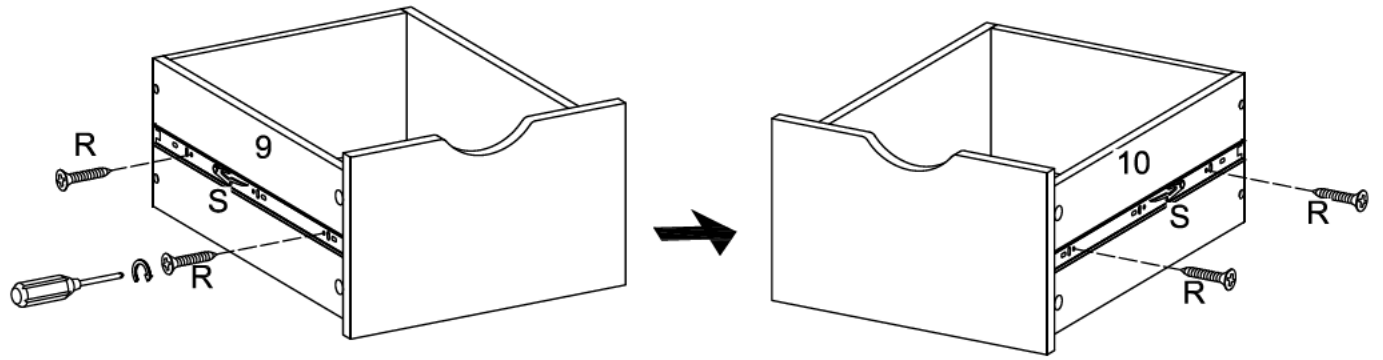

Step 14

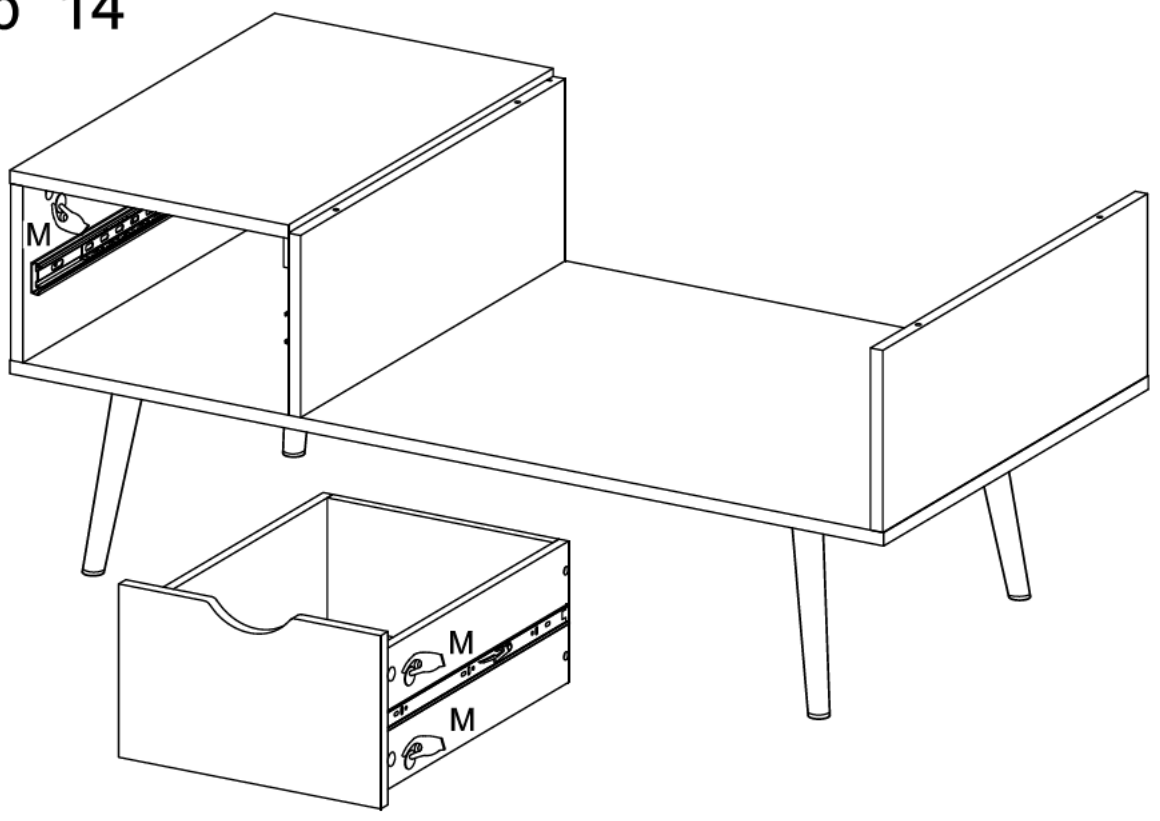

Step 15

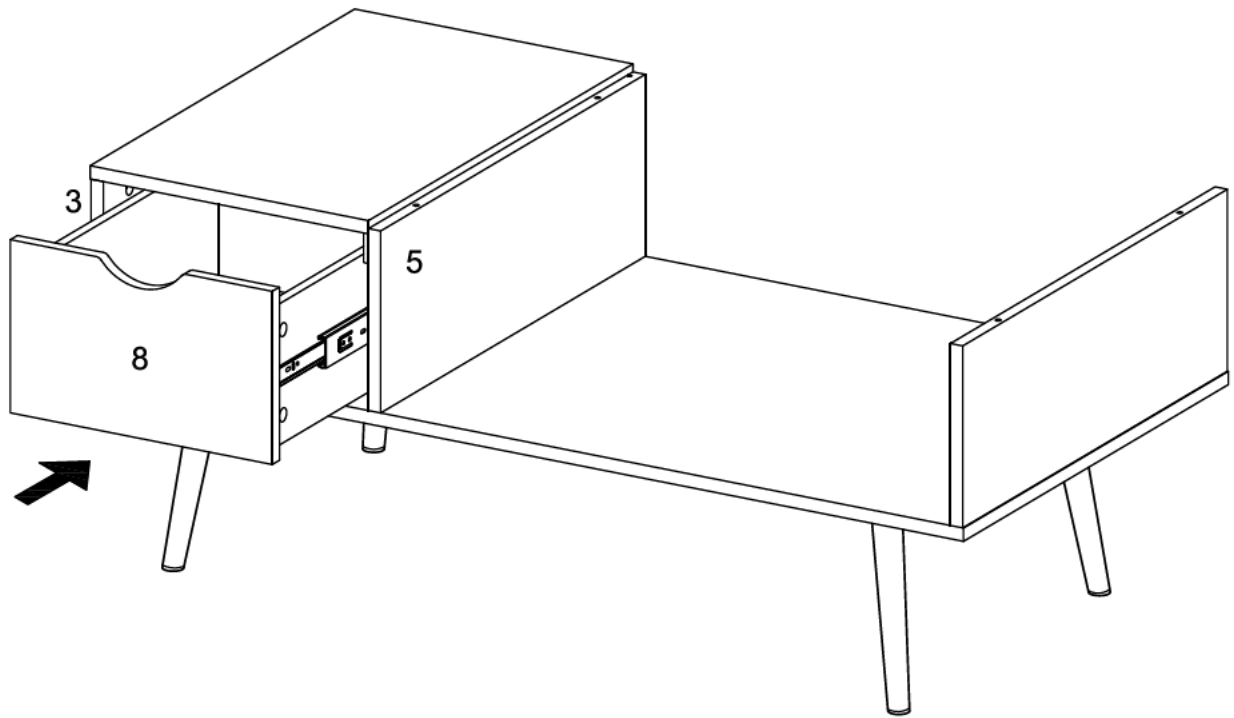

Step 16

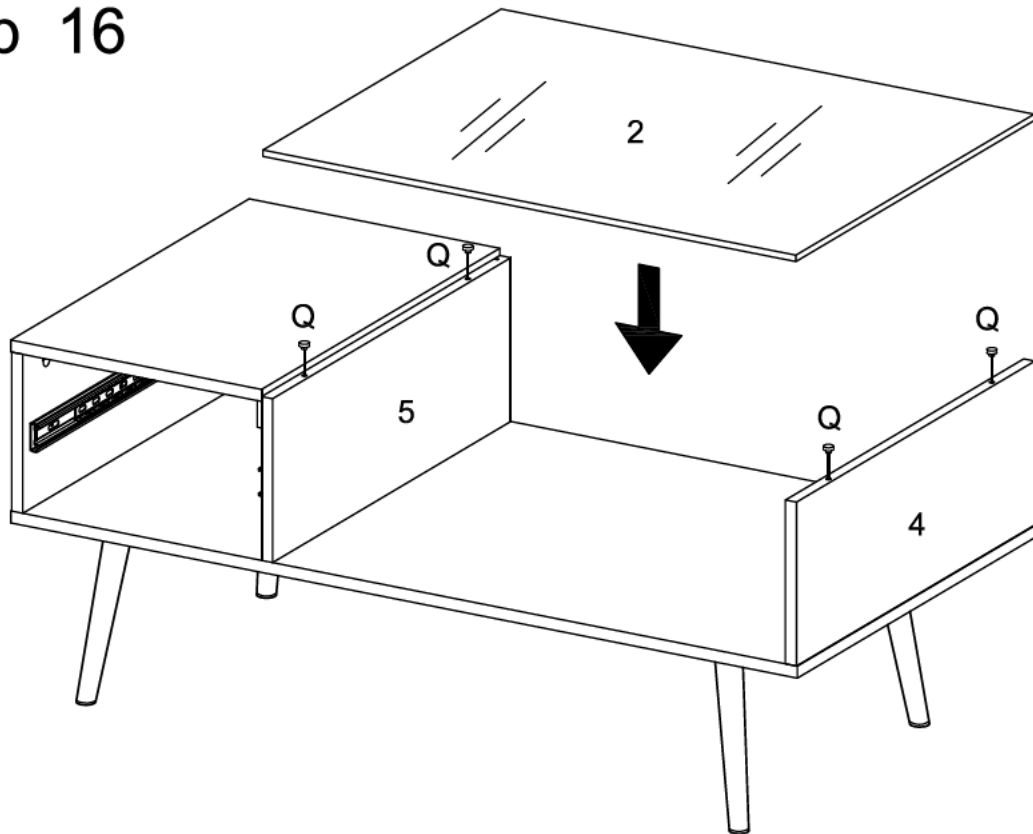

Step 17

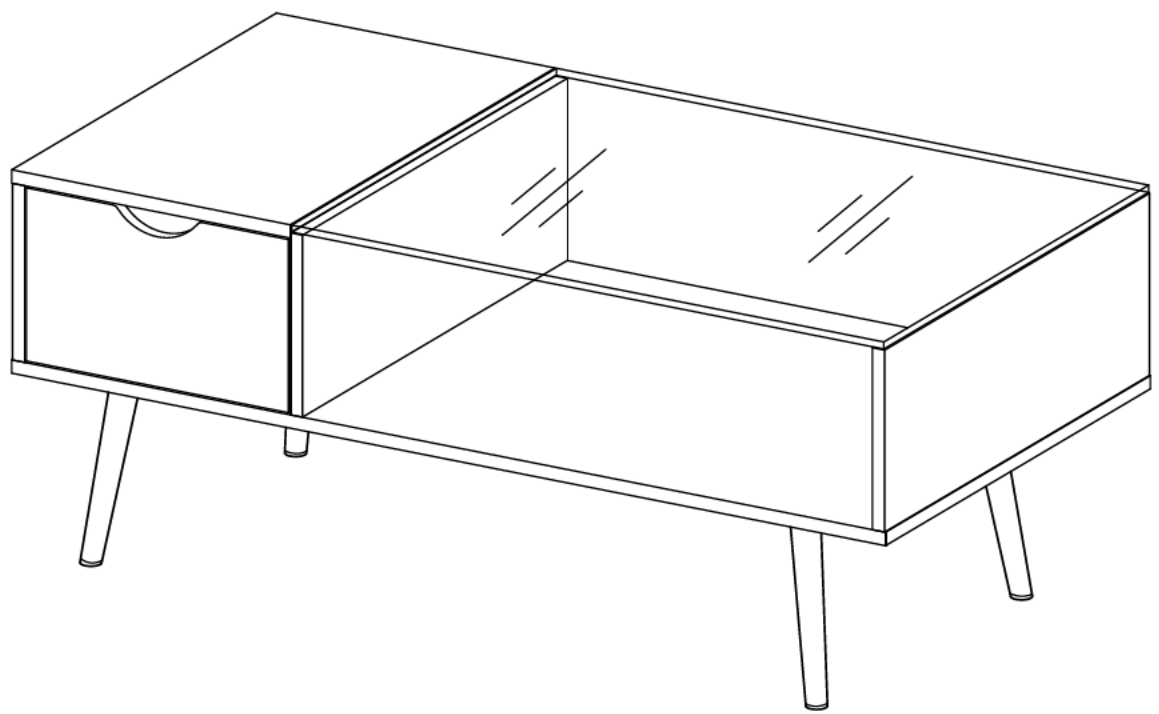

Final Assembly