

# Assembly Instructions

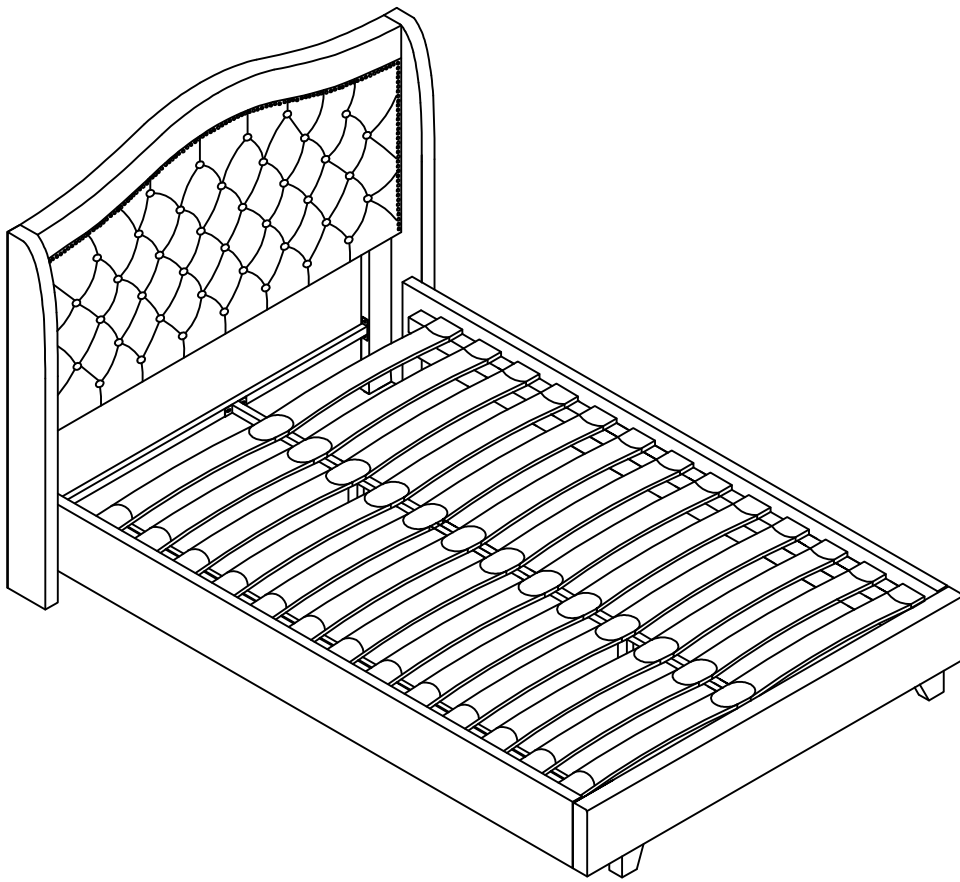

## ASSEMBLY RATING

The Assembly Rating is a 5-point system that shows the degree of effort needed in assembling a specific product (with 1 being easy and 5 being difficult). For some products, two persons are recommended.

EASY



DIFFICULT

## Tools Required For Assembly:

Allen Wrench

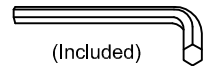

(Included)

Wrench

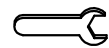

(Included)



2 PERSONS RECOMMENDED

# ASSEMBLY & CARE ADVICE

FOR YOUR FURNITURE TO LAST, CORRECT ASSEMBLY AND PROPER MAINTENANCE ARE NECESSARY. PLEASE FOLLOW THE INFORMATION PROVIDED BELOW TO FULLY ENJOY YOUR FURNITURE.

## BASIC ASSEMBLY TECHNIQUES



When lock or spring washer is used in an assembly, please make sure the lock or spring washer is placed between the larger flat washer and the head of the screw or bolt.



Position each part correctly and insert screws or bolts into their respective holes by hand tighten or using the proper hand tool. Only tighten when step is completed or when instructed to do so.



Use cardboard or carpet area when assembling furniture to prevent scratches. Make sure the furniture rests on a flat and level surface with each leg evenly touching the floor.



Some furniture comes with height adjustment knobs underneath each leg. To lower or to raise each leg, you need to turn clockwise or counterclockwise, respectively.



Make sure all parts are properly aligned, then use the appropriate hand tool to completely tighten the bolts or screws. Do not use power tools and do not overtighten.



Save the instructions and store the Allen wrench or any supplied tool for later maintenance. After two weeks, check and tighten any loose hardware and repeat again every six months thereafter.

IT IS THE USER'S RESPONSIBILITY TO MAINTAIN THE FURNITURE. THE HARDWARE MAY LOOSEN OVER TIME AND MAY CAUSE THE FURNITURE TO BE WOBBLY AND UNABLE TO SUPPORT ITS INTENDED WEIGHT CAPACITY. THIS MAY LEAD TO COLLAPSE AND MAY CAUSE SERIOUS INJURY.

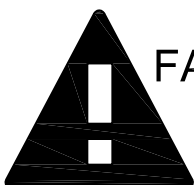

**FAILURE TO FOLLOW THE GUIDELINES ABOVE MAY RESULT IN INJURY AND/OR PROPERTY DAMAGE.**



Before you begin, please read Page 2 of "Assembly and Care Advice".

And remember, do not tighten until each step is completed or instructed.

## Parts List

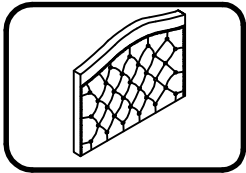

#1 x 1pc  
Headboard

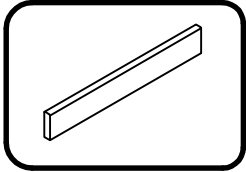

#2 x 1pc  
Footboard

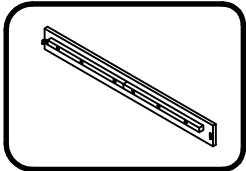

#3 x 2pcs  
Side Rail

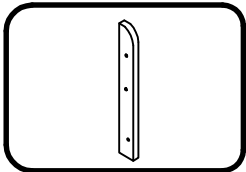

#4 x 2pcs  
Wings (L&R)

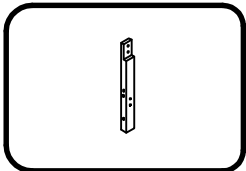

#5 x 2pcs  
HB Leg (L&R)

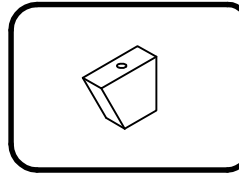

#6 x 2pcs  
FB Feet

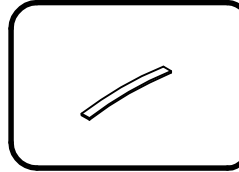

#7 x 26pcs  
Slat

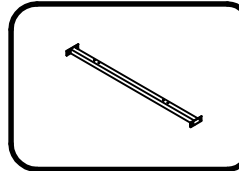

#8 x 1pc  
Central Support Rail

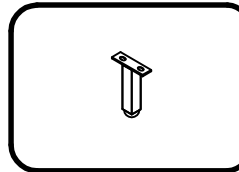

#9 x 2pcs  
Support Leg

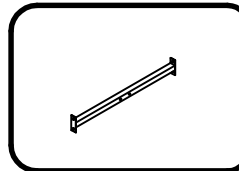

#10 x 1pc  
Cross Bar

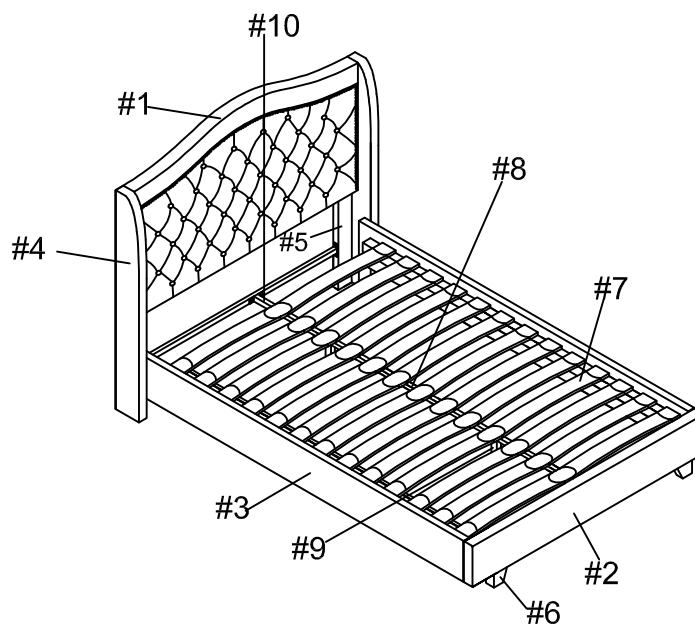



Before you begin, please read Page 2 of "Assembly and Care Advice".

And remember, do not tighten until each step is completed or instructed.

## Hardware List



#A x 1pc  
Allen Wrench



#B x 14pcs  
Bolt 5/16" x 1-1/2"



#C x 14pcs  
Bolt 5/16" x 2"



#D x 2pcs  
Bolt 5/16" x 2-1/2"



#E x 2pcs  
Bolt 5/16" x 4"



#F x 22pcs  
Flat Washer Ø5/16" x 19mm



#G x 10pcs  
Flat Washer Ø5/16" x 22mm



#H x 32pcs  
Lock Washer Ø5/16"



#I x 6pcs  
Hex Nut

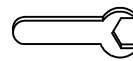

#J x 1pc  
Wrench



#K x 26pcs  
End Cap



#L x 13pcs  
Center Plastic Connector

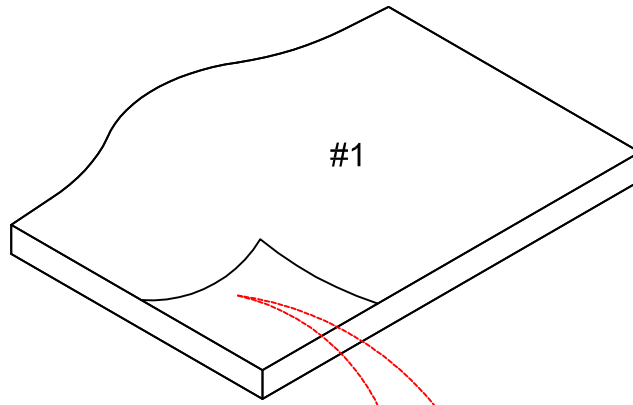

Remove every parts from the back compartment of the headboard (#1).

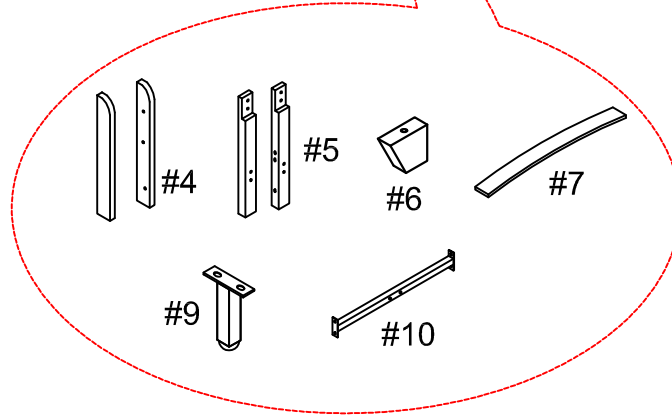

#C x 4pcs  
#G x 4pcs  
#H x 4pcs

Prepare 4 bolts assembly by inserting lock washer (#H), then flat washer (#G) onto bolts (#C). Align headboard legs (#5R/L) to the holes of the headboard (#1), then secure by using bolts (#C).

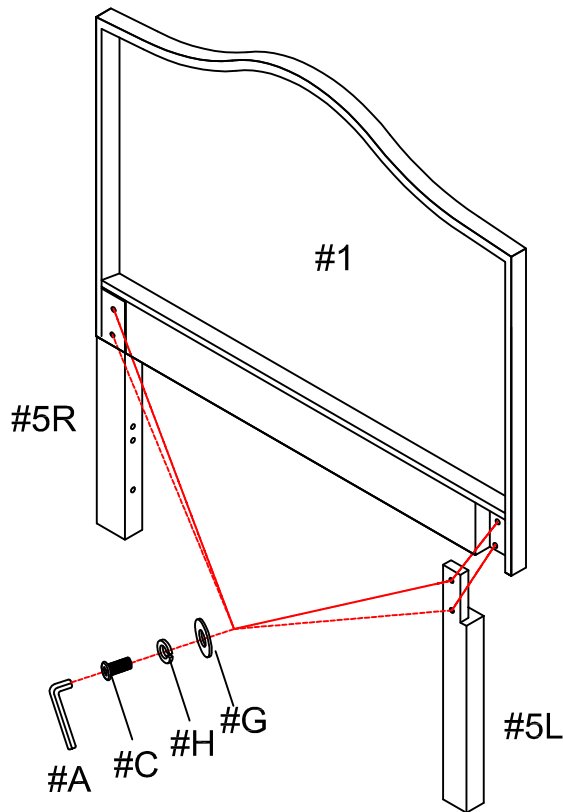



#B x 4pcs  
 #C x 4pcs  
 #E x 2pcs  
 #F x 4pcs  
 #G x 6pcs  
 #H x 10pcs

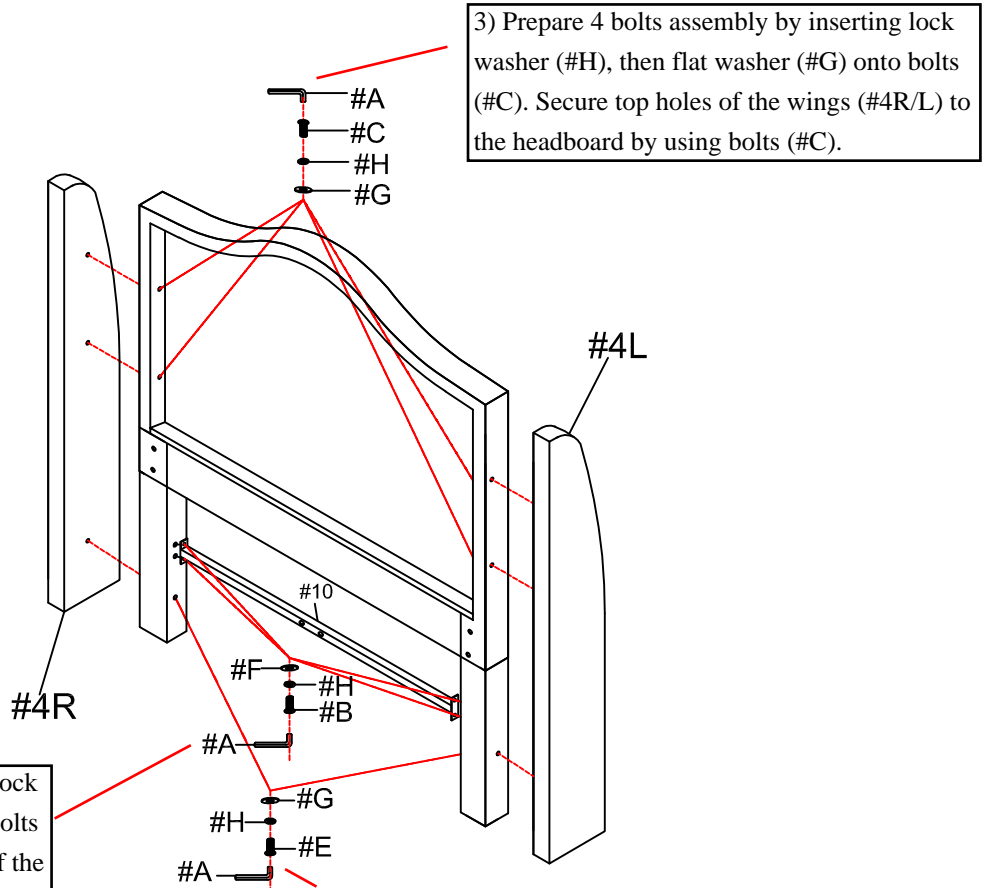

3) Prepare 4 bolts assembly by inserting lock washer (#H), then flat washer (#G) onto bolts (#C). Secure top holes of the wings (#4R/L) to the headboard by using bolts (#C).

1) Prepare 4 bolts assembly by inserting lock washer (#H), then flat washer (#F) onto bolts (#B). Align cross bar (#10) to the holes of the headboard legs, then secure by using bolts (#B).

2) Prepare 2 bolts assembly by inserting lock washer (#H), then flat washer (#G) onto bolts (#E). Align wings (#4R/L) to the holes of the headboard, then secure bottom holes by using bolts (#E).



#D x 2pcs  
 #F x 2pcs  
 #H x 2pcs

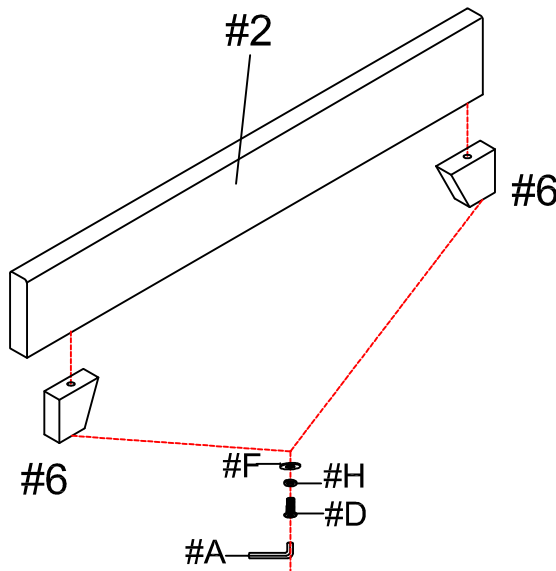

Prepare 2 bolts assembly by inserting lock washer (#H), then flat washer (#F) onto bolts (#D). Align legs (#6) to the holes of the footboard (#2), then secure by using bolts (#D).



#B x 8pcs  
#F x 8pcs  
#H x 8pcs

Prepare 8 bolts assembly by inserting lock washer (#H), then flat washer (#F) onto bolts (#B). Attach bolts (#B) half way into the holes of the headboard (#1) and footboard (#2), then hook the side rails (#3) to bolts (#B). Fully secure bolts (#B).

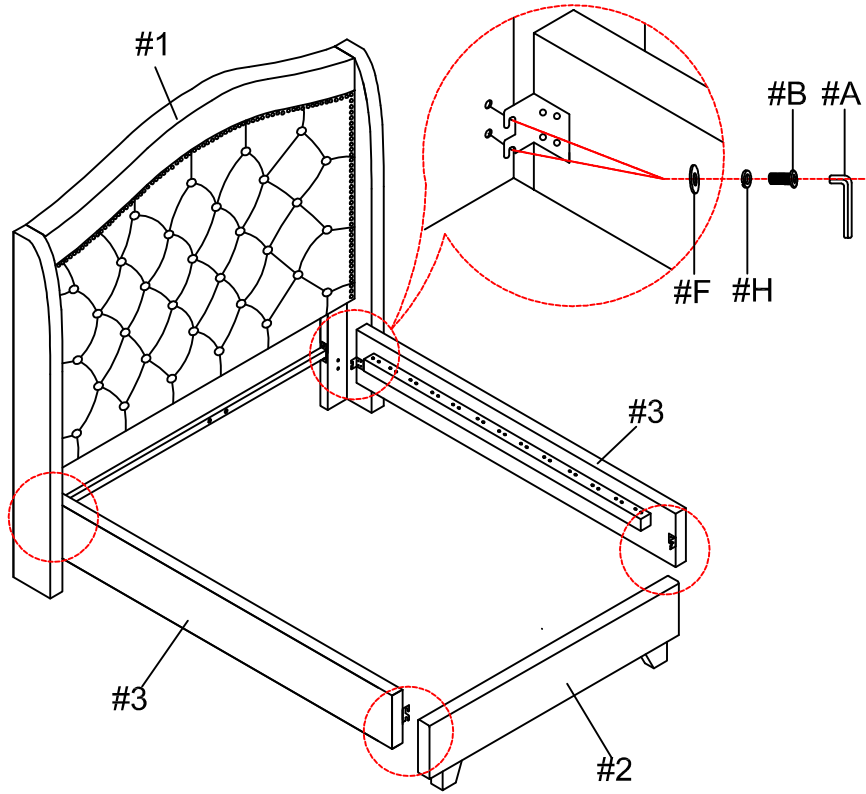

#C x 4pcs  
#F x 4pcs  
#H x 4pcs  
#I x 4pcs

Prepare 4 bolts assembly by inserting lock washer (#H), then flat washer (#F) onto bolts (#C). Align support legs (#9) to the holes of the central support rails (#8). Secure by using bolts (#C) and hex nut (#I).

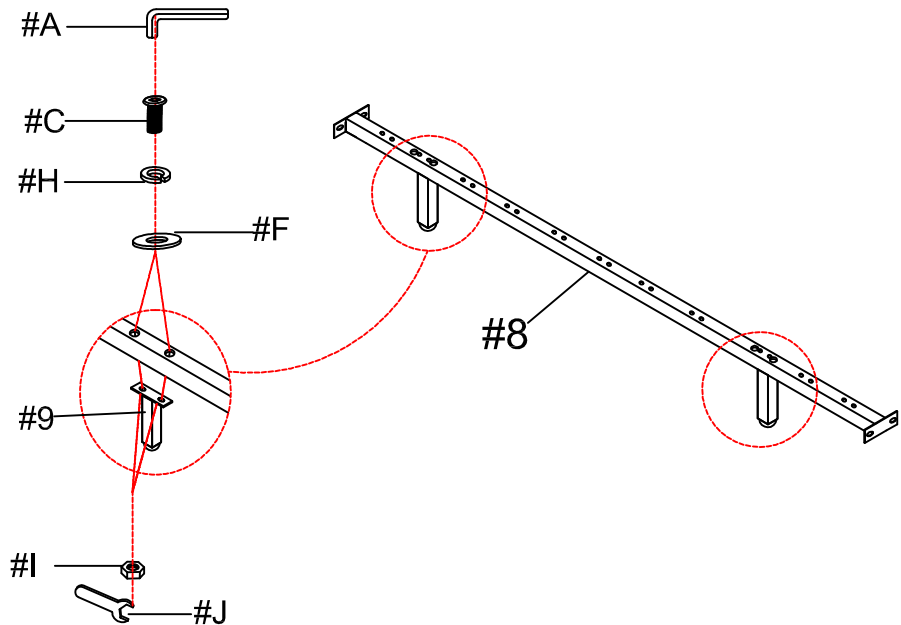



- #B x 2pcs
- #C x 2pcs
- #F x 4pcs
- #H x 4pcs
- #I x 2pcs

1) Prepare 4 bolts assembly by inserting lock washer (#H), then flat washer (#F) onto bolts (#B). Align central support rails (#8) to the holes of the footboard (#2), then secure by using bolts (#B).

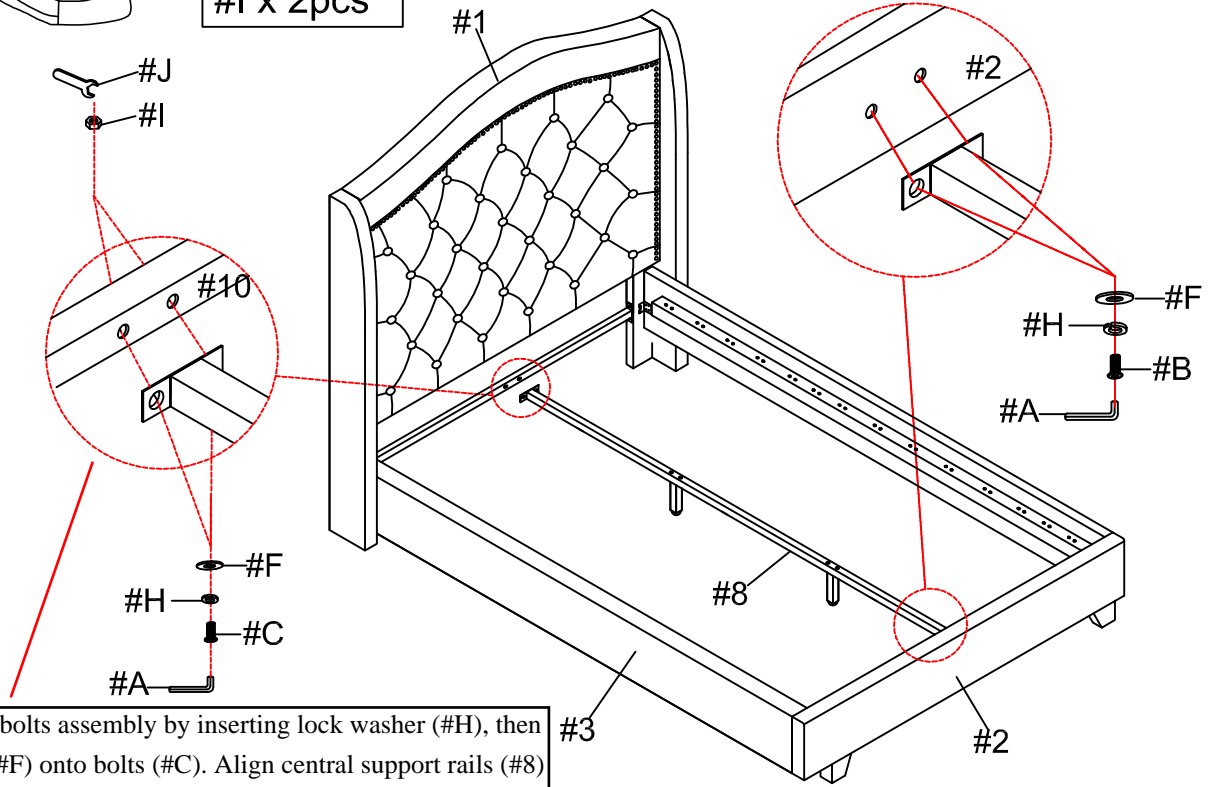

2) Prepare 4 bolts assembly by inserting lock washer (#H), then flat washer (#F) onto bolts (#C). Align central support rails (#8) to the cross bar (#10), then secure by using bolts (#C).



Insert slats (#7) into plastic connectors (#K,L), then attach the slats to the bed.

