

ASSEMBLY INSTRUCTION

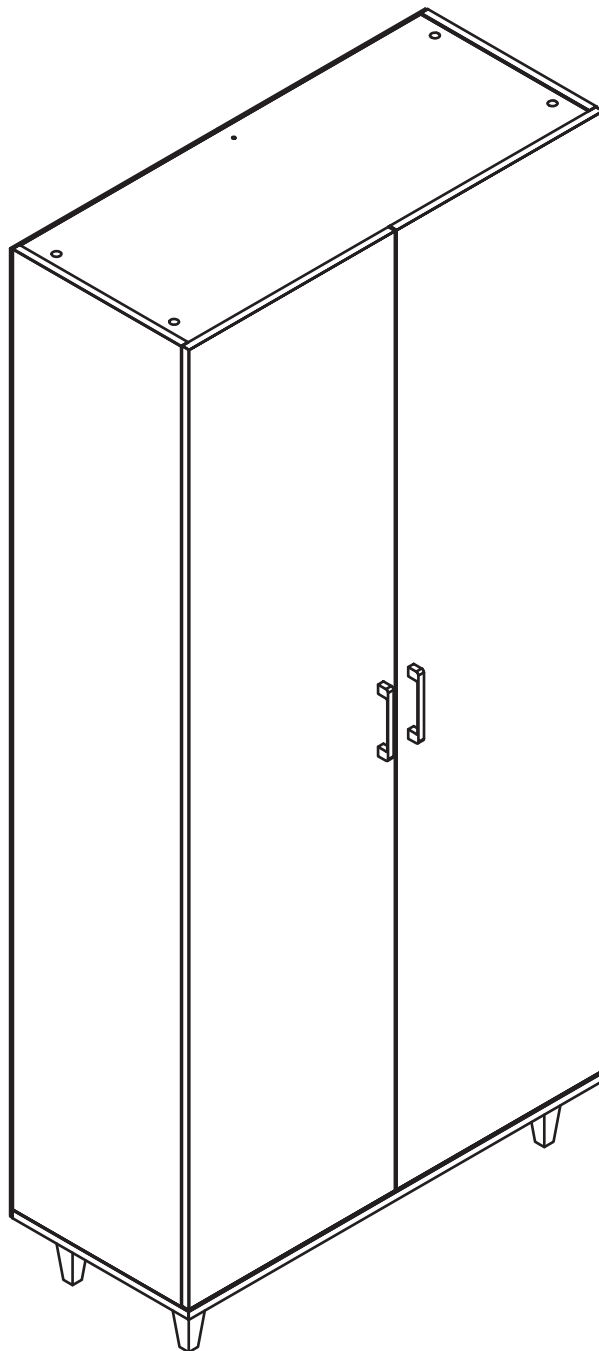

INSTALLATION PREPARATION

Dear Customer,

Thank you for choosing us. Before you begin assembly, check that you have all the parts and hardware shown on this page.

If there is any item missing, please mark the item, indicating quantity required and send picture to us. We will arrange replacement at first time.

If feel question in assemble, Please feel free to ask us. Customer satisfaction is our prime.

Your order means a lot to us!

Thank you!

TOOLS NEEDED

Crosshead screwdriver

Flat-head screwdriver



PARTS LIST

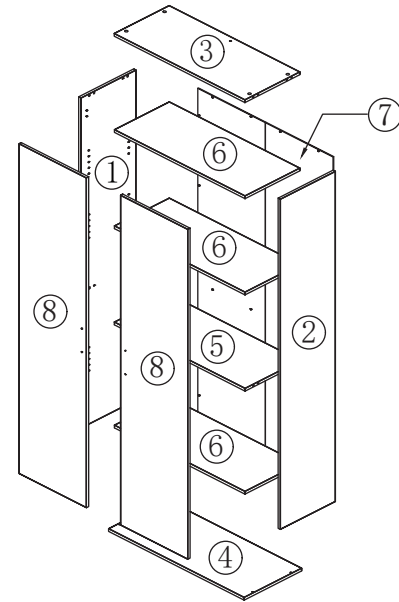

HARDWARE LIST

A:Cam lock
Φ15*11mm



8 PCS

B:Cam bolt
Φ6*35mm



8 PCS

C:Wooden Dowel
Φ8*30mm



8 PCS

D:Full Cover Hinge

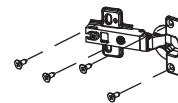

6 PCS

E:Handle

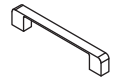

2 PCS

F:Pull Screw
M4*18



4 PCS

G:Screw
M5*40



4 PCS

H:Screw
M4*13



21 PCS

I:Shelf Support



12 PCS

J:Plug(low)
Φ15*3mm



8 PCS

K:Foot

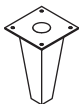

5 PCS

L:Screw
M4*20



22 PCS

M:safety bracket

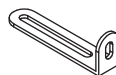

1 PCS

N:Expansion screw
M6*60



1 PCS

STEP 01

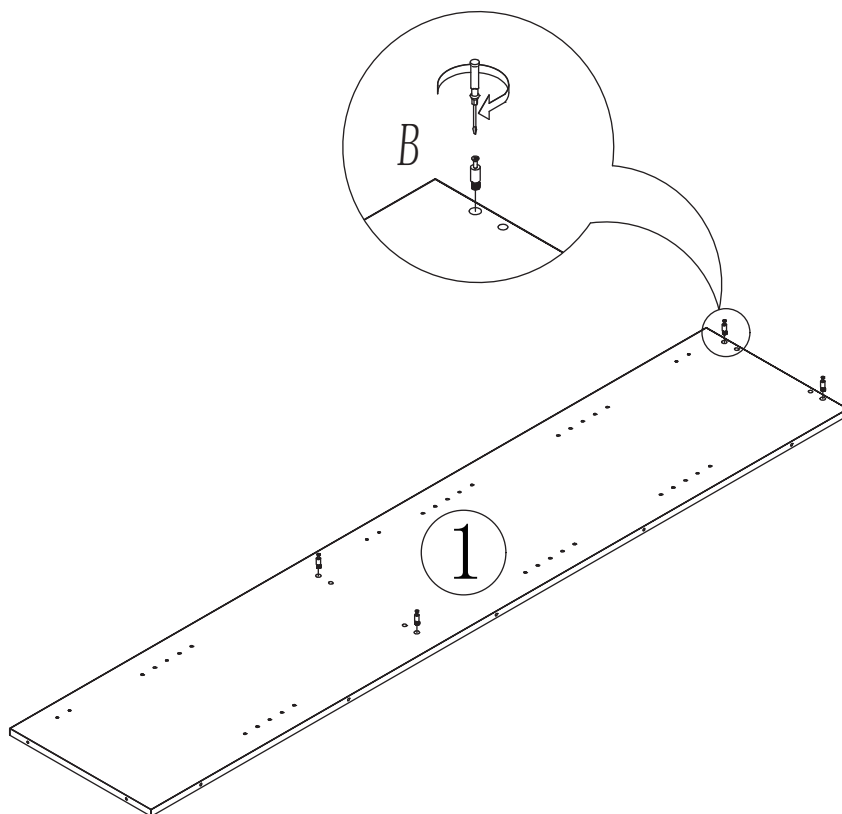

STEP 02

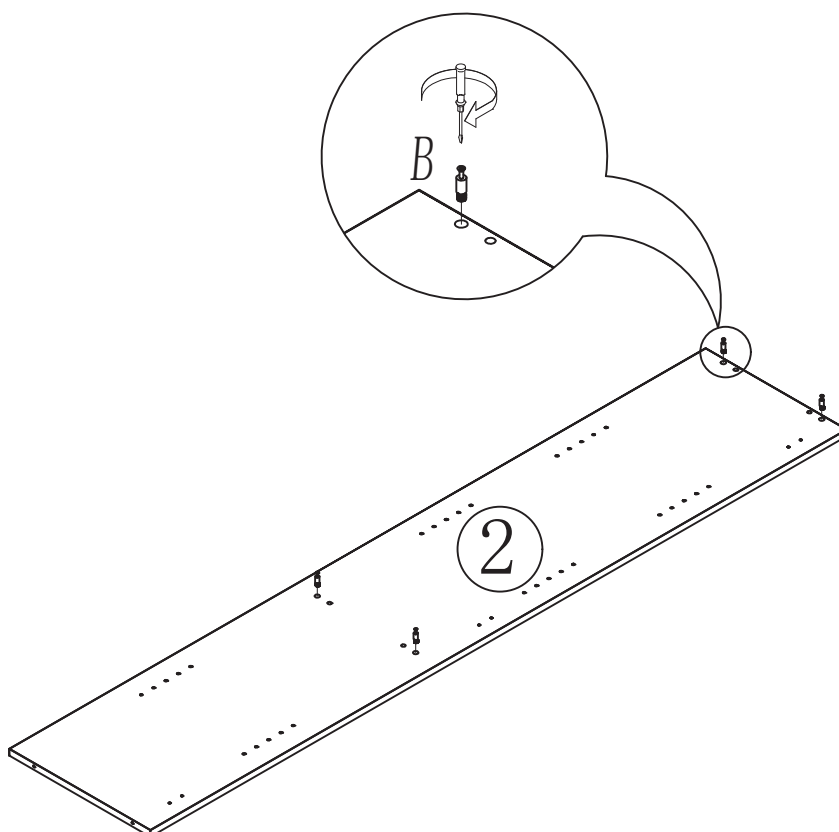

STEP 03

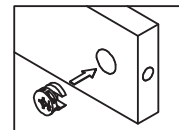
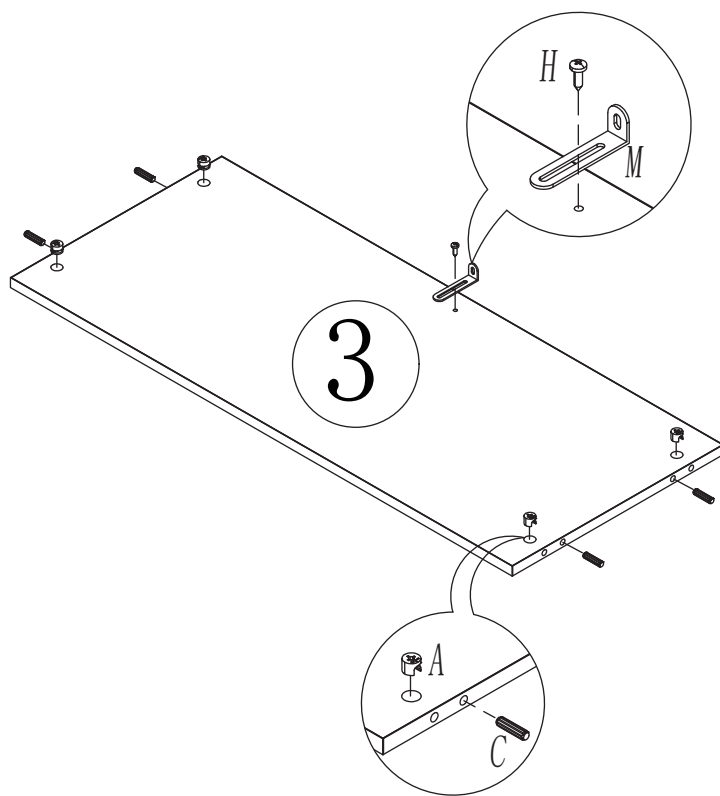

Direction of arrow to the side hole

STEP 04

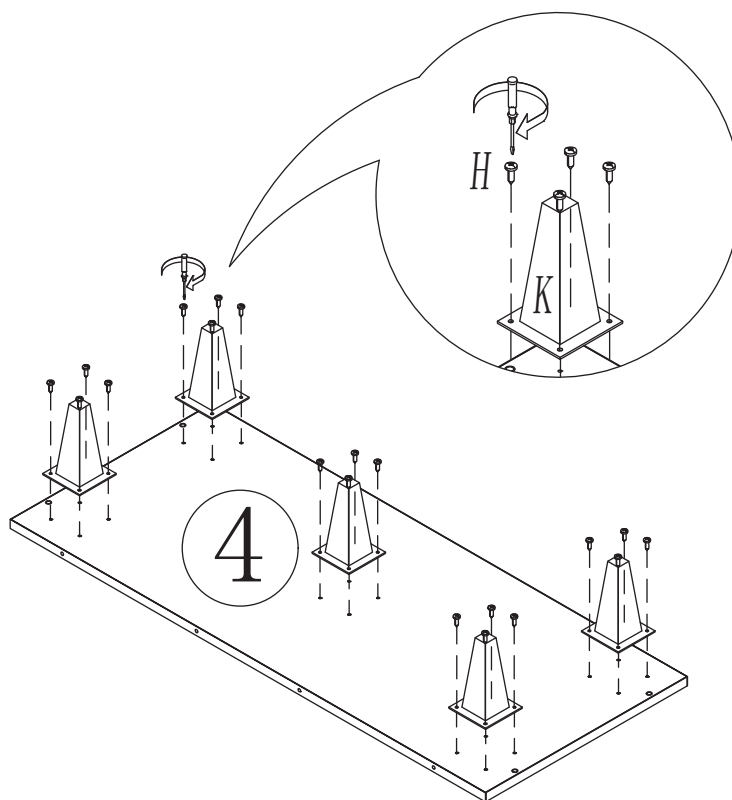

INSTALLATION PREPARATION

STEP 05

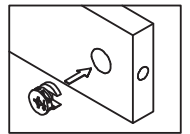
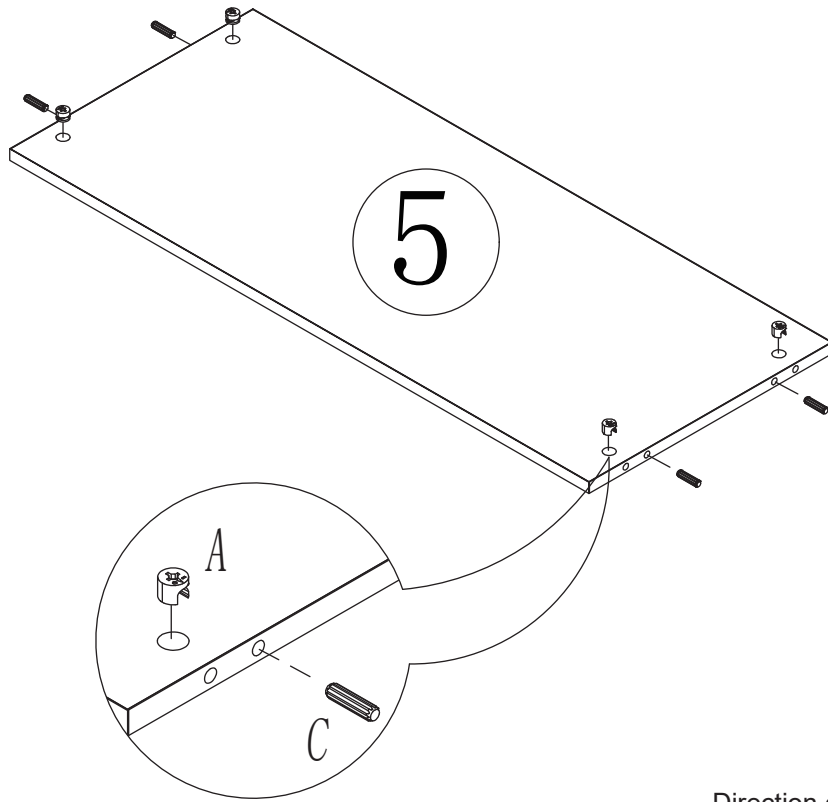

Direction of arrow to the side hole

STEP 06

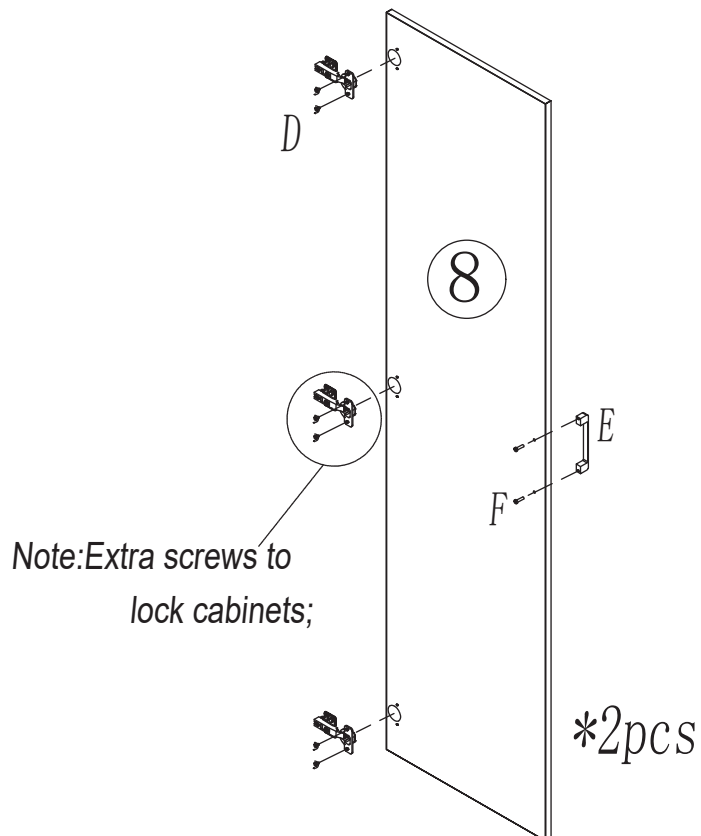

Note: Extra screws to
lock cabinets;

*2pcs

STEP 07

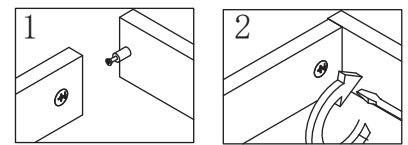
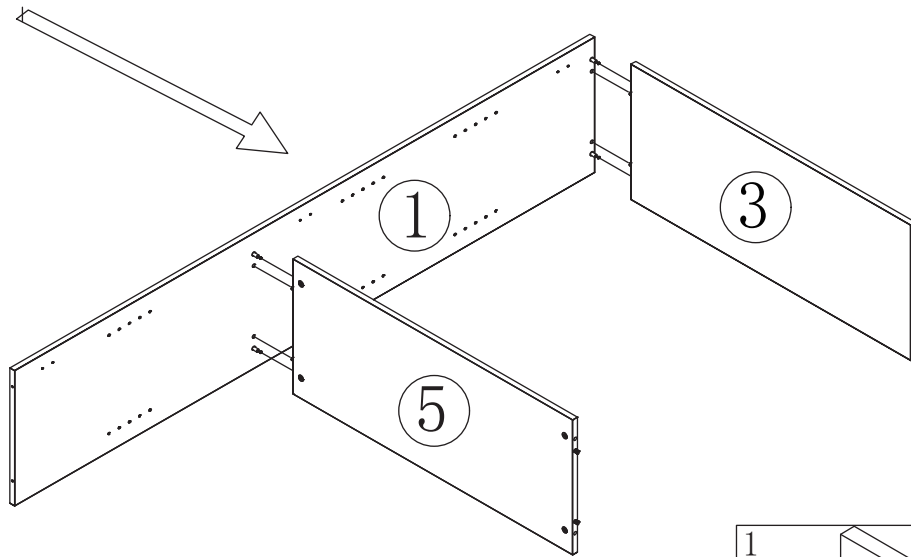

Remember to lock the Cam Lock

STEP 08

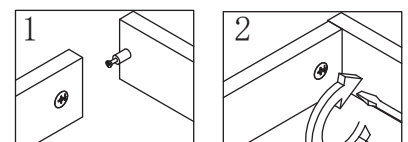
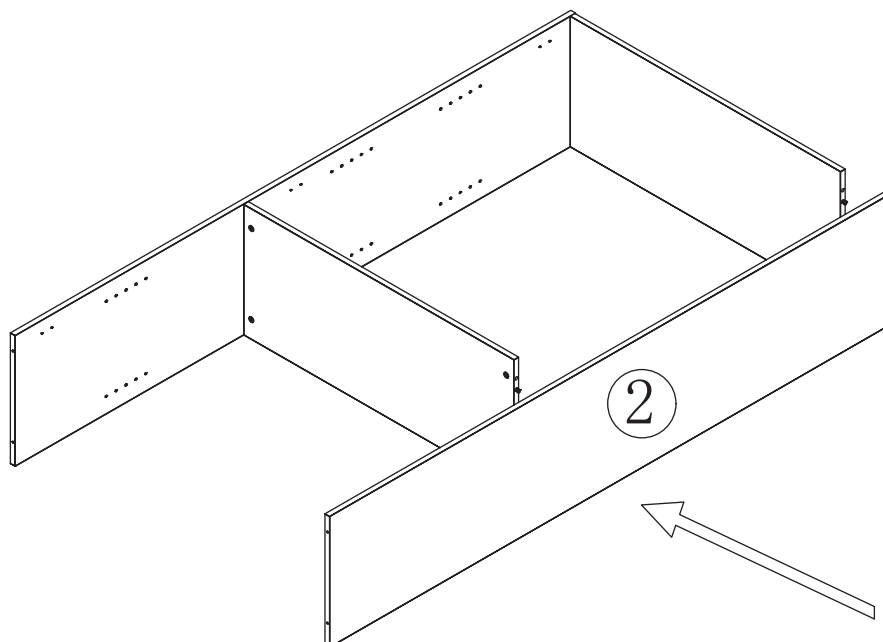

Remember to lock the Cam Lock

STEP 09

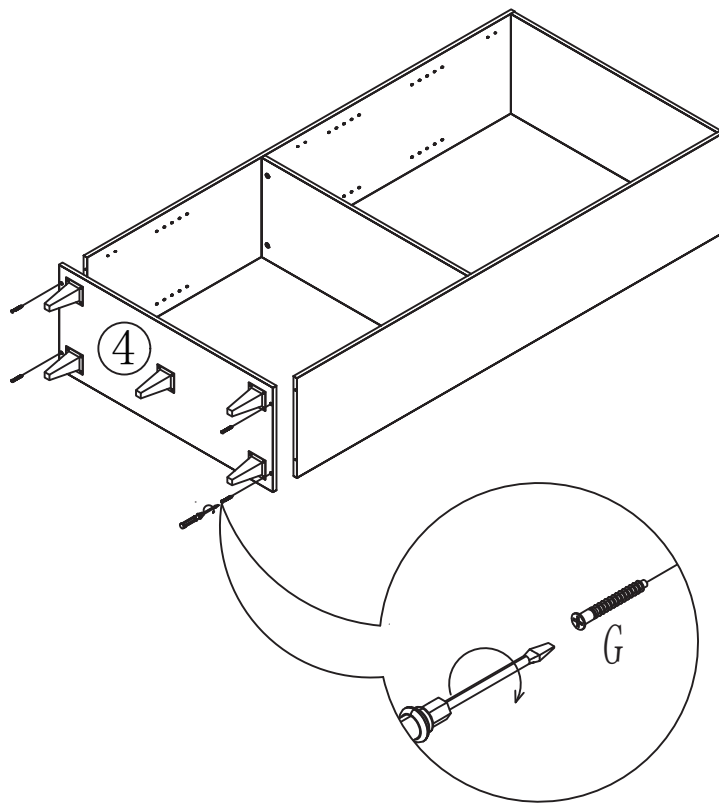

STEP 10

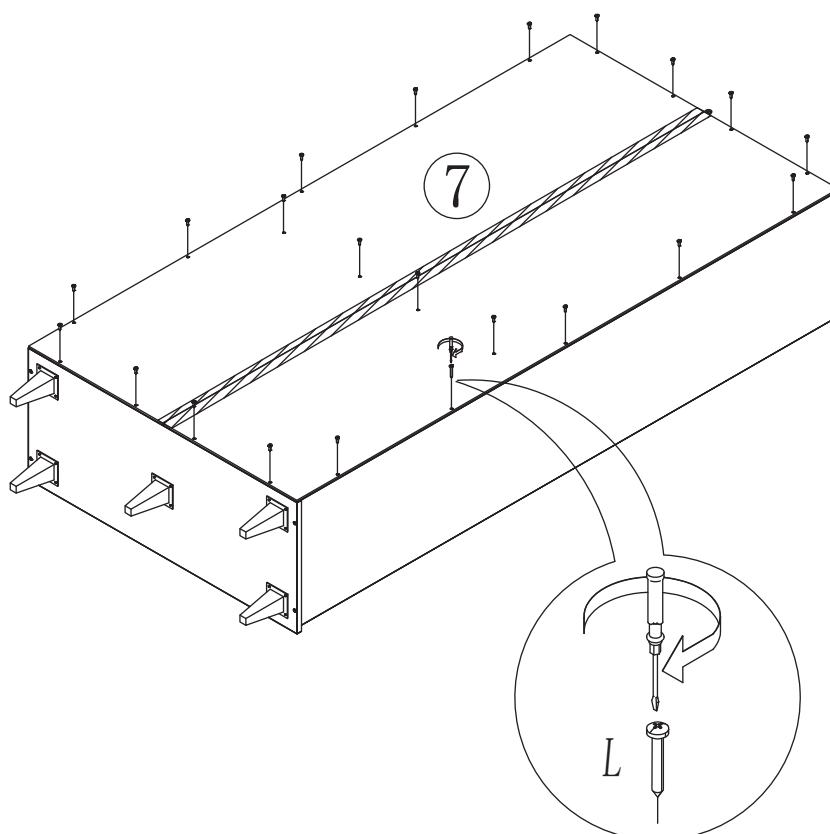

STEP 11

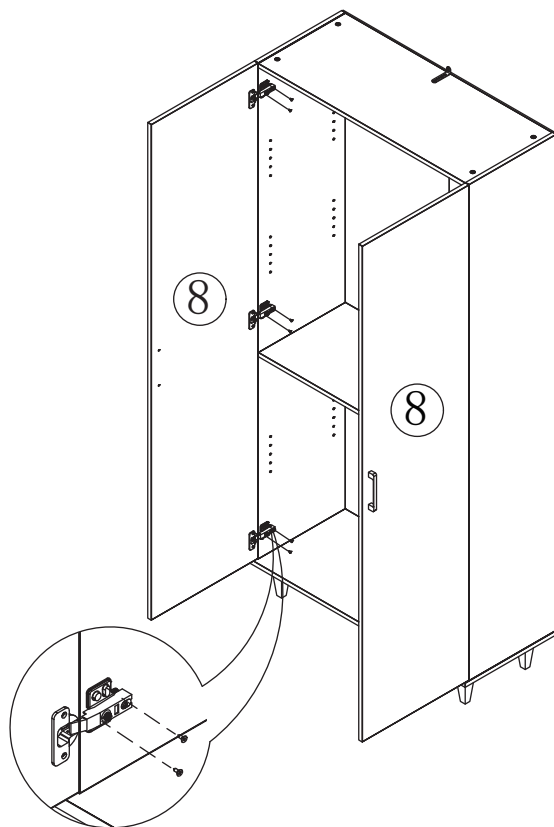

STEP 12

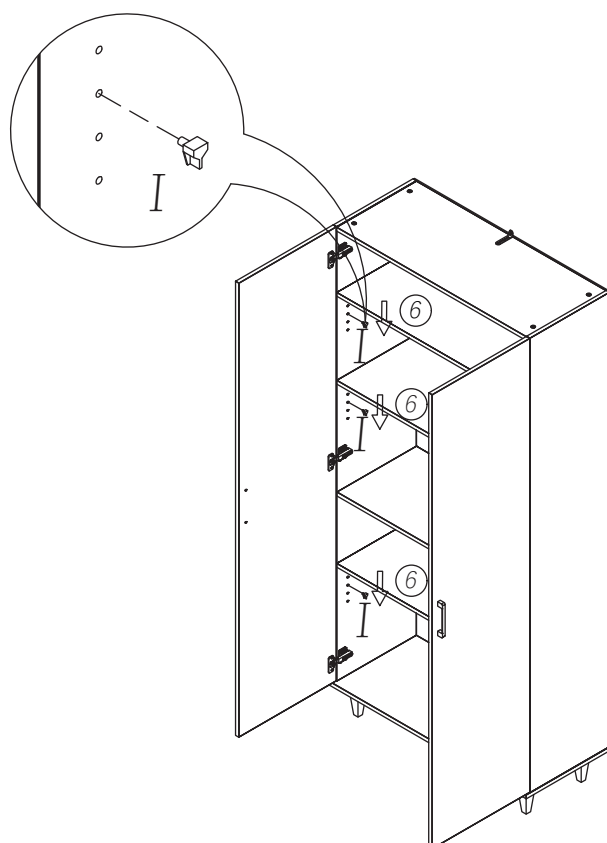

STEP 13

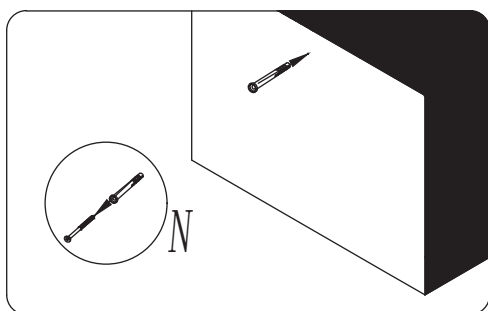
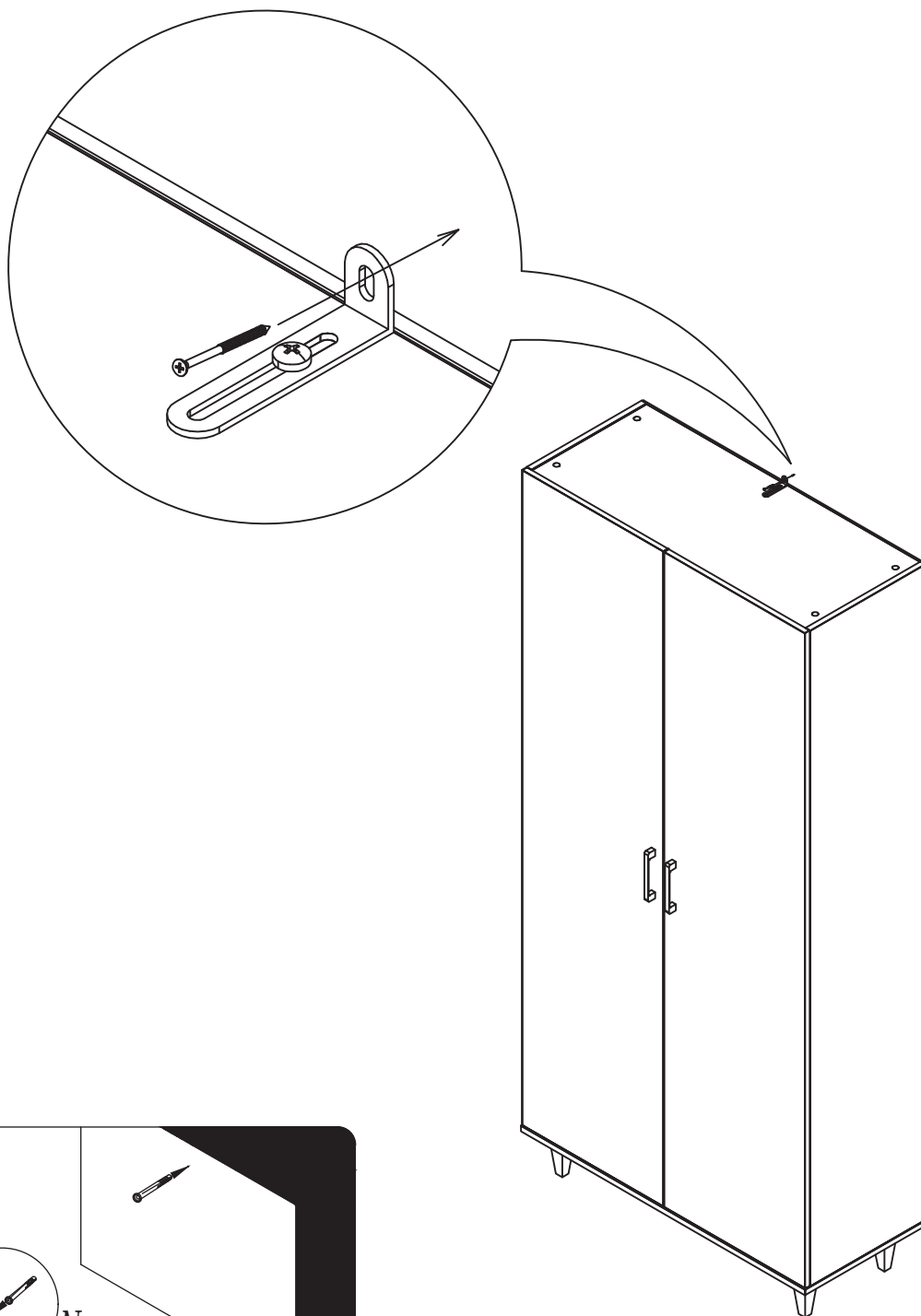
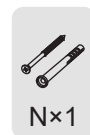

First of all, remove the screw of the expansion tube, and then drive the expansion tube in the position of the drilled hole in the wall.

INSTALLATION PREPARATION

If there is misalignment after you install, adjust the screw to the best condition.

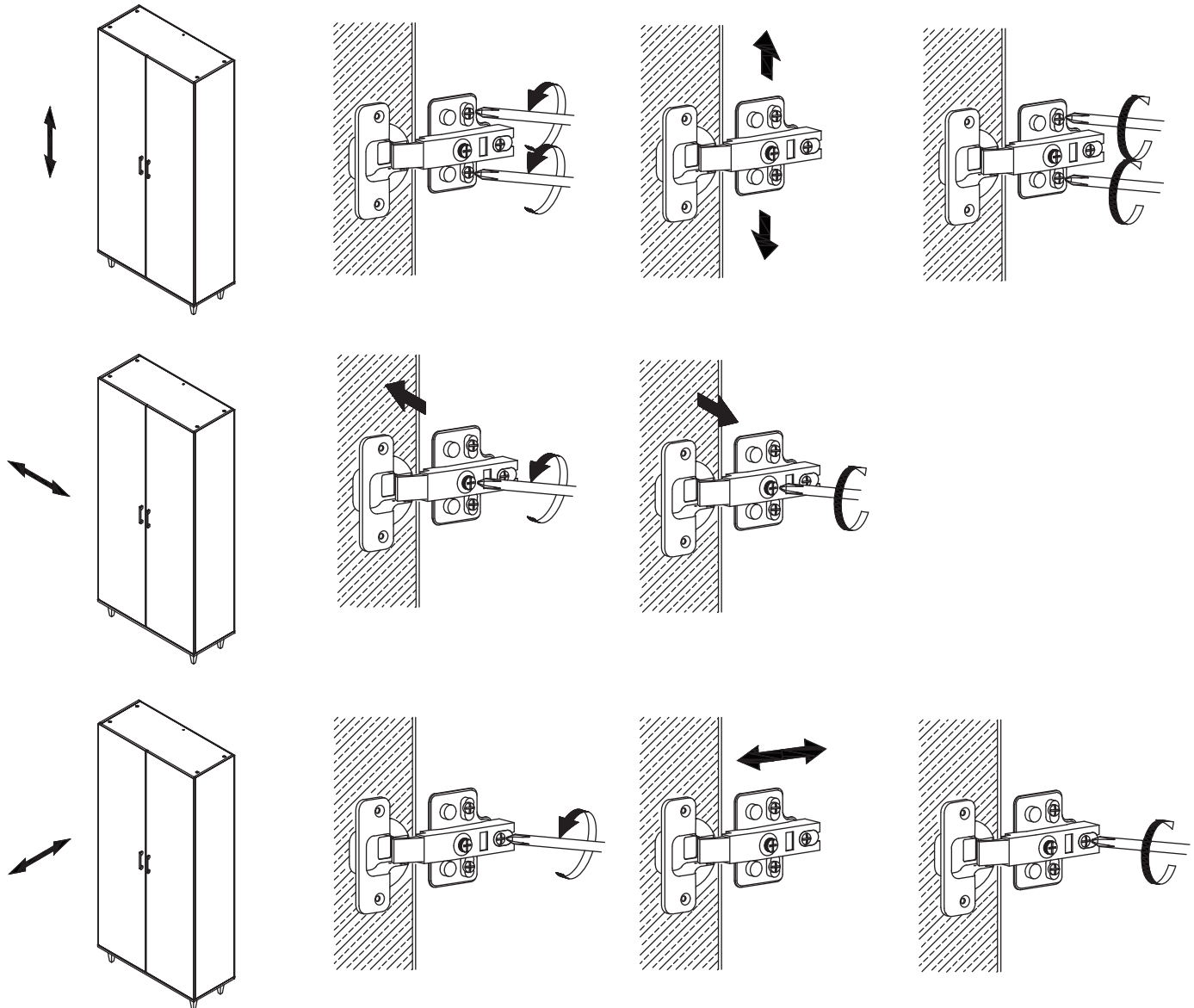

Thank you for your recent order.

We strive to provide customers with great services and satisfaction.

If any questions, please contact us.

Our customer support team is ready to help!