

ASSEMBLY INSTRUCTIONS & PARTS IDENTIFICATION 70" TV CONSOLE

Thank you for purchasing this quality product. Be sure to check all packing material carefully for small parts that may have come loose inside the carton during shipment.

Parts key							
No	Code	Qty	Description	No	Code	Qty	Description
1	A	4 pcs	Drawer Complete	5	E	4 pcs	Drawer Stop
2	B	4 pcs	Pull w/Screws for Drawer	6	F	1 pc	Shelf
3	C	4 pcs	Outer Drawer Glide (Long)	7	G	4 pcs	Floor Glide
4	D	4 pcs	Inner Drawer Glide (Short)	8	H	2 pcs	Floor Leverler

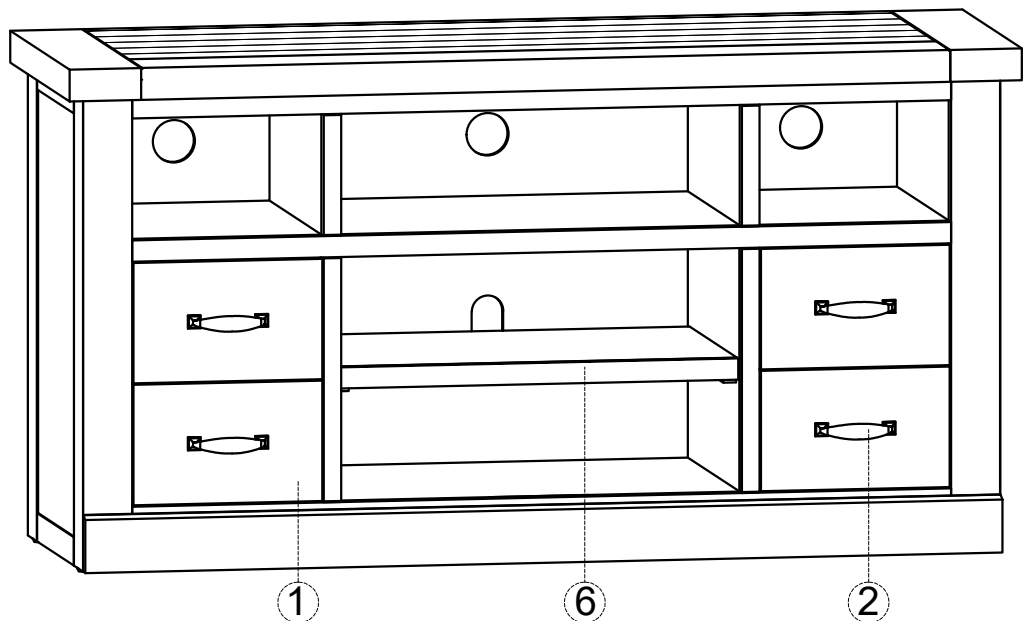
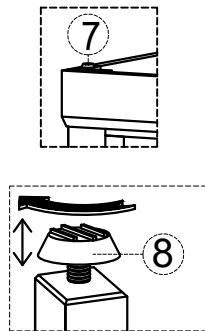
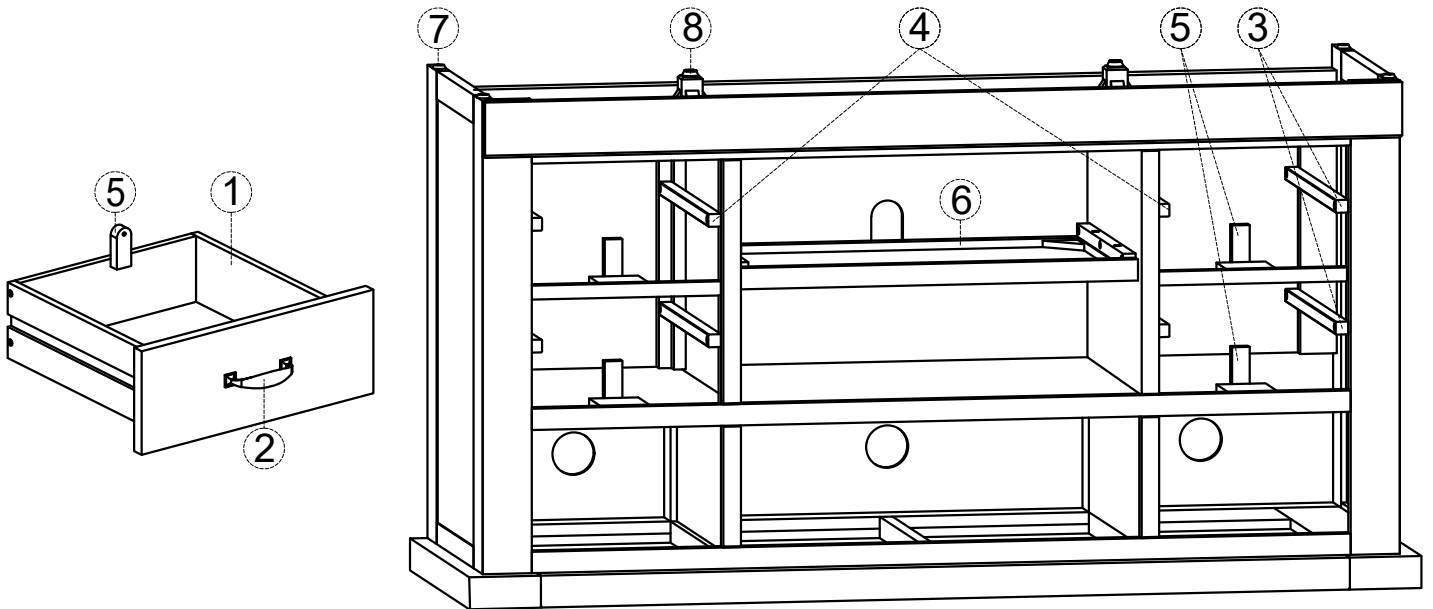

ASSEMBLY INSTRUCTIONS & PARTS IDENTIFICATION PIER & BRIDGE

Thank you for purchasing this quality product. Be sure to check all packing material carefully for small parts that may have come loose inside the carton during shipment.

Parts key

No	Code	Qty	Description	No	Code	Qty	Description
1	A	1 pc	Right Facing Front Panel w Door	8	I	1 pc	Right Side Facing Door
1A	B	1 pc	Left Facing Front Panel w Door	8A	J	1 pc	Left Side Facing Door
2	C	2 pcs	Back Panel	9	K	4 pcs	Door Hinge
3	D	2 pcs	Pier Top	10	L	2 sets	Door Catch
4	E	2 pcs	Storage Box Top	11	M	2 sets	Knob w/Screw for Door
5	F	2 pcs	Storage Box Bottom	12	N	8 pcs	Floor Leveler
6	G	4 pcs	Shelf	13	O	2 sets	Anti - tip kit
7	H	4 pcs	Side Panel	14	P	1 pc	Bridge

THIS ASSEMBLY WILL REQUIRE TWO PEOPLE

STEP 1

- Carefully layout all parts on a smooth flat surface to prevent scratches. Separate and arrange all hardware.
- Lay the back panel assembly flat. Attach the Storage Box Bottom (5) to the bottom of the back assembly by inserting a Long Bolt (C), a Lock Washer (B) and a Flat Washer (A) into each of the two corners. (Diagram 1)
Hand tighten with the Allen Key.







STEP 2

- Attach the Storage Box Top (4) to the back panel with a Medium Bolt (D), a Lock Washer (B) and a Flat Washer (A) into the two holes and hand tighten with the Allen Key. (Diagram 2)

STEP 3

- Attach the two shelves (6) by firmly inserting the dowels on the shelf into the slots on the back panel uprights.
- Attach the Pier Top (3) to the Back Panel by inserting a Long Bolt (C), a Lock Washer (B) and a Flat Washer (A) into each of the two corners. (Diagram 3)
Hand tighten with the Allen Key.

Hardware kit

No	Description	Qty
A	 Flat washer Ø8 36 pcs	36 pcs
B	 Lock washer Ø8 36 pcs	36 pcs
C	 Bolt To Connect Top-Bottom w 2 Main Panel Ø6.3 x 50 16 pcs	16 pcs
D	 Bolt To Connect Middle Frame & Bridge Ø6.3 x 30 12 pcs	12 pcs
E	 Bolt To Connect Metal Bracket Ø6.3 x 15 8 pcs	8 pcs
F	 Allen Key K4 1 pc	1 pc
I	 Metal Bracket 4 pcs	4 pcs

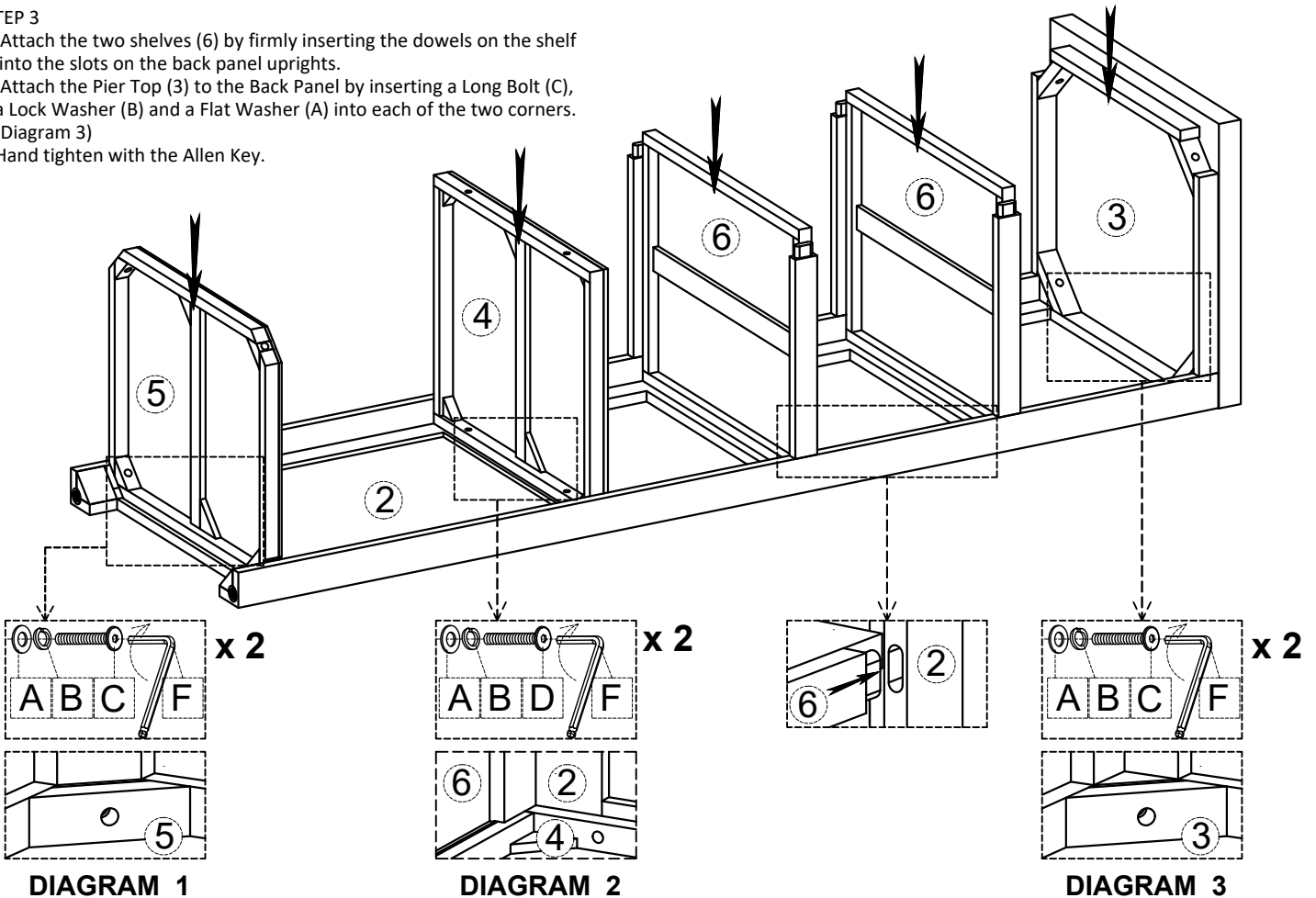

ASSEMBLY INSTRUCTIONS & PARTS IDENTIFICATION PIER & BRIDGE

- STEP 4**
- Position the two Side Panels (7) into place. Carefully place the Front Panel (Left side or Right side) with the Door on top of the unit, taking care to align all the parts. Once in place, first secure the Front panel to the Pier Top by inserting a Long Bolt (C), a Lock Washer (B) and a Flat Washer (A) into each of the two corners. (Diagram 4) Hand tighten with the Allen Key.
 - Next secure the Storage Box Top to the Front Panel with a Medium Bolt (D), a Lock Washer (B) and a Flat Washer (A) into the two holes and hand tighten with the Allen Key. (Diagram 2) Finally secure the Storage Box Bottom (5) to the Front Panel by inserting a Long Bolt (C), a Lock Washer (B) and a Flat Washer (A) into each of the two corners. (Diagram 1) Hand tighten with the Allen Key.

CHECK ALL BOLTS TO MAKE SURE THEY ARE TIGHTENED BEFORE STANDING THE PIER UPRIGHT.
REPEAT THESE INSTRUCTIONS FOR THE SECOND PIER.

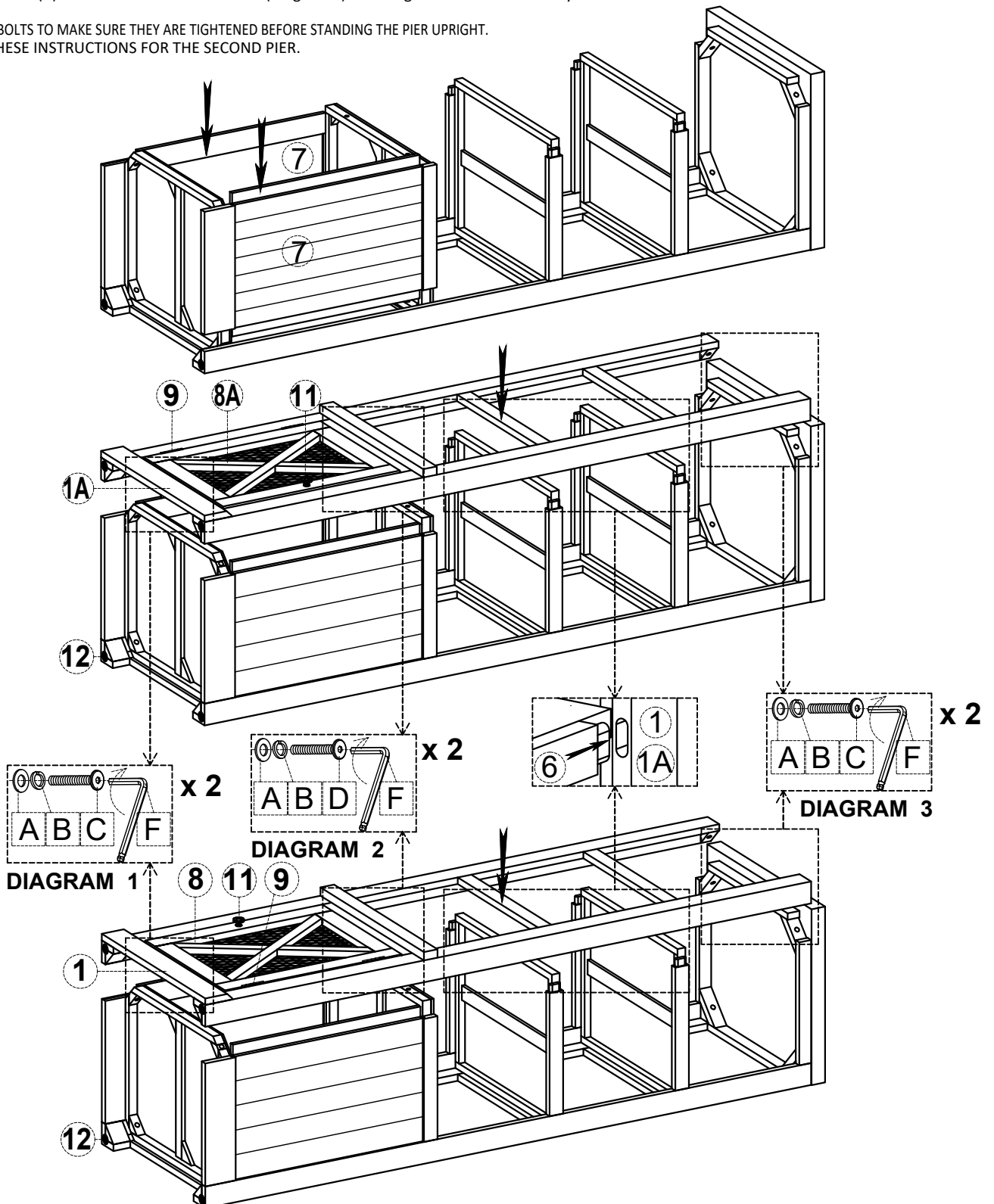

ASSEMBLY INSTRUCTIONS & PARTS IDENTIFICATION

PIER & BRIDGE

ATTACHING THE BRIDGE TO THE PIERS

- Depending on the size of the Console being used, place the piers either 60" or 70" apart. Attach the Bridge to each pier using a Medium Bolt (D), a Lock Washer (B) and a Flat Washer (A) into the two holes and hand tighten with the Allen Key.

ATTACHING THE CONSOLE TO THE PIERS

- Attach the Metal Brackets to the back of the Piers using the Small Bolt (E), a Lock Washer (B) and a Flat Washer (A). Hand tighten with the Allen Key.
- Slide the console into place and secure the console to the piers using the Small Bolt (E), a Lock Washer (B) and a Flat Washer (A). Hand tighten with the Allen Key.
- Carefully slide the complete four piece unit into place AND ATTACH BOTH SETS OF THE ANTI - TIP HARDWARE PER INSTRUCTIONS.
- Levelers on the bottom of the piers can be adjusted if needed.

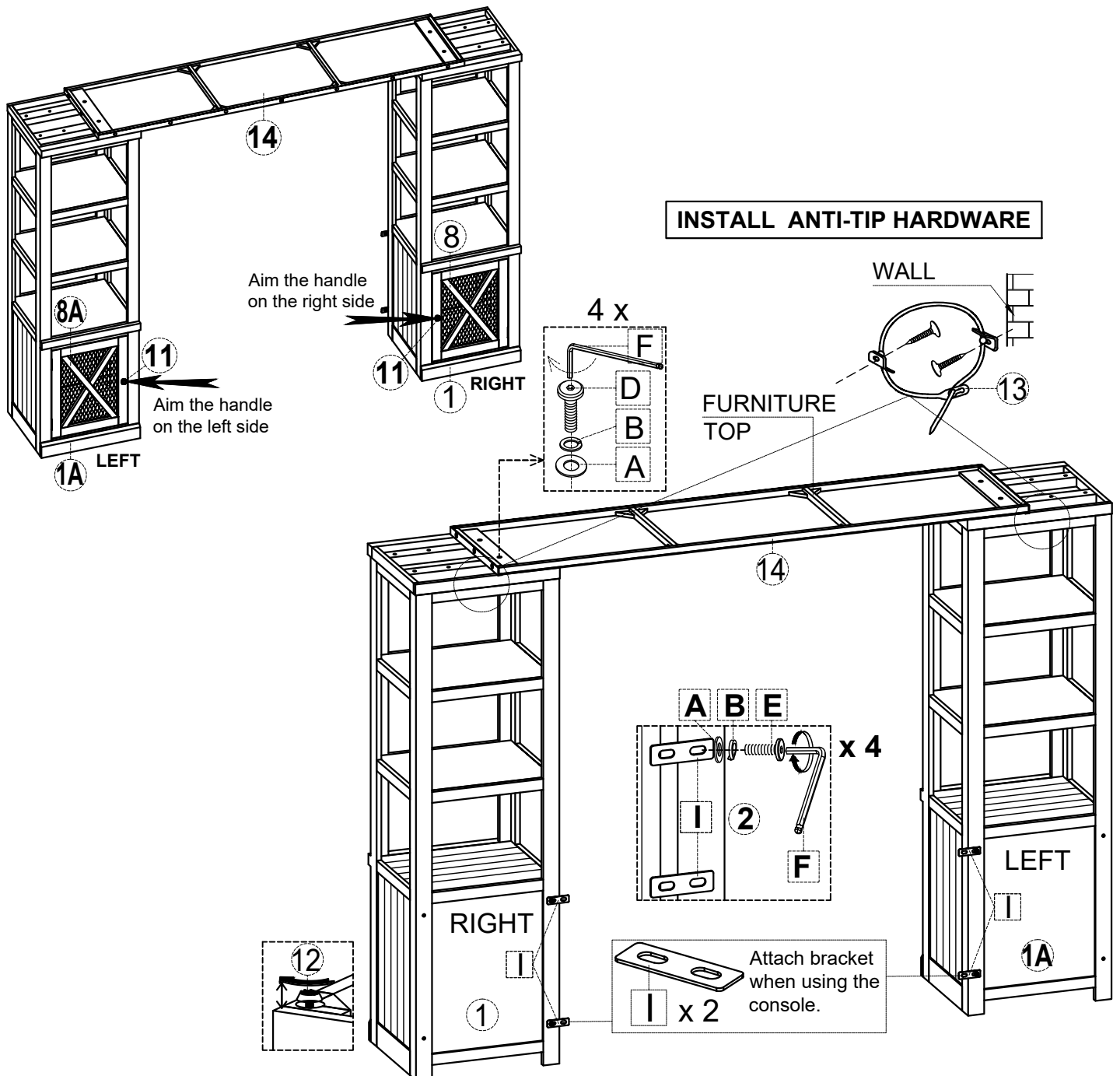

PLEASE NOTE :

This assembly will require two people. To help prevent the possibility of tip-over, install the ANTI-TIP hardware restraints provided.