

AI - ILSC48VDWM

Assembly Instructions

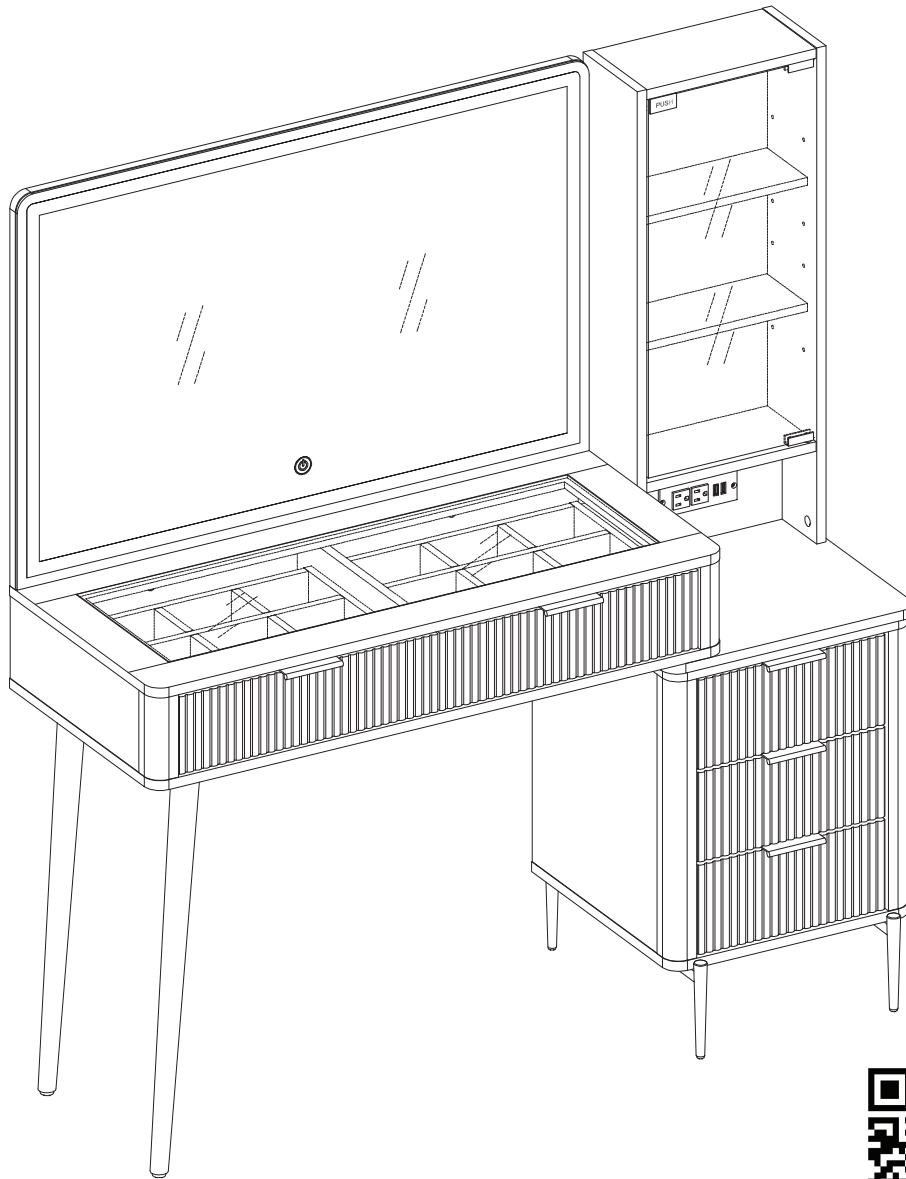

ILSC48VDWM



Scan for Help!

Assembly Guide/Customer Support

Date 2025-03-25 Rev.02-A

General Assembly Guidelines

- I. Ensure that all parts and hardware are available before beginning assembly.
- II. Follow each step carefully to ensure the proper assembly of this product.
- III. Two people are recommended for ease in the assembly of this product.
- IV. A Phillips head screwdriver is required for the assembly of this product .

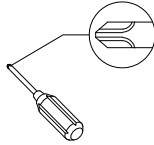

- V. The provided glue is to secure wood dowels in place . When first inserting dowels , locate the appropriate hole for the dowel , place a small amount of glue in the hole and insert the dowel . Wipe away excess glue immediately.

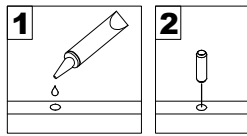

In future assembly steps when dowels are necessary to attach assembly parts together , place a small amount of glue on the end of the dowel before attaching parts together . Wipe away excess glue immediately.

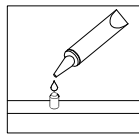

VI HOW THE KNOCK DOWN (KD) ASSEMBLY SYSTEM WORKS

- 1.Screw the Cam Bolt into the pre-drilled hole on the panel. Make sure Cam Bolt goes into the pre-drilled hole on the end of panel for Cam Lock.
- 2.Insert the Cam Lock into the pre-drilled large hole on the panel. Make sure the arrow on the face of Cam Lock points towards Cam Bolt.
- 3.Take a Phillips screwdriver and rotate the Cam Lock clockwise to lock the Cam Bolt.
- 4.Use the sticker to conceal the Cam.

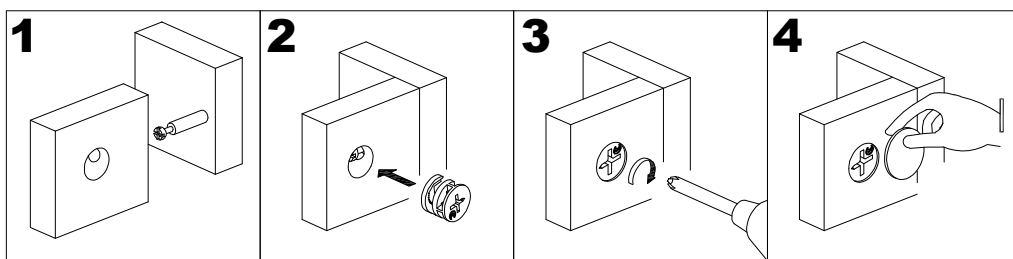

- VII. Power tools should not be used to assemble this product .

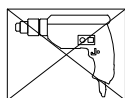





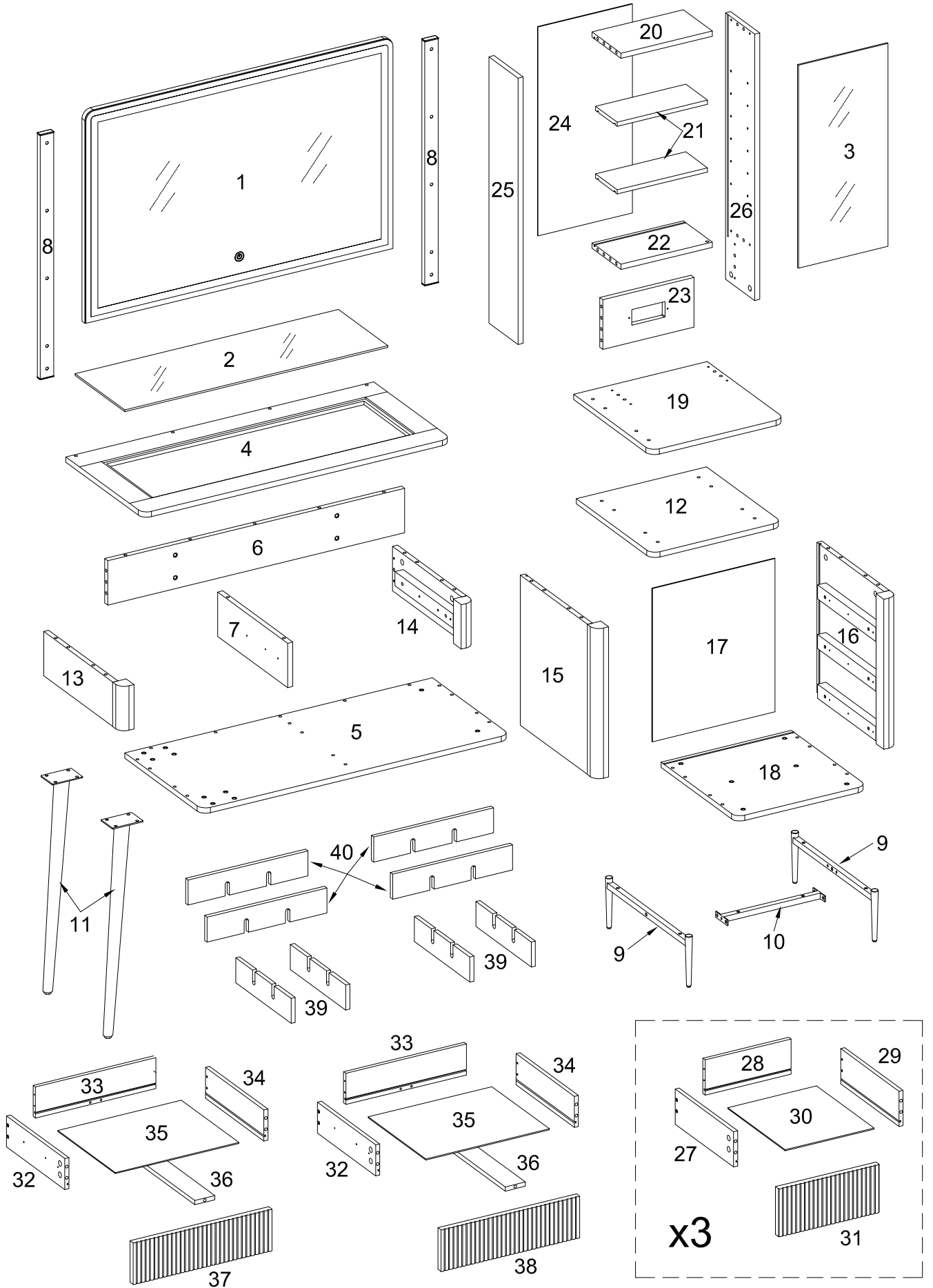



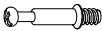

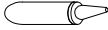





⚠ WARNING **INGESTION HAZARD DEATH** or serious injury can occur if ingested A swallowed button cell or coin battery can cause **Internal Chemical Burns** in as little as **2 hours**. **KEEP** new and used batteries **OUT OF REACH OF CHILDREN** **Seek immediate medical attention** if a battery is suspected to be swallowed or inserted inside any part of the body.

Parts List



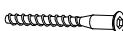



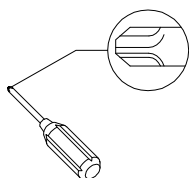





Hardware List

A		Ø8x30mm	Large Dowel	40 pcs
B		Ø6x35mm	Cam bolt	55 pcs
C		Ø15x11mm	Large Cam lock	33 pcs
D		Ø30mm	Cam cover	55 pcs
E			Glue	2 pcs
F		Ø5x16mm	Shelf support pin	8 pcs
G		Ø3.5x14mm	Screw	10 pcs
H			Knob	5 pcs
J			Plastic wedge	12 pcs
K		Ø3x17mm	Flat-head screw	12 pcs
L		Ø6x20mm	Small Dowel	10 pcs
M			Metal plate	3 pcs
N		10"	Drawer slider	2 sets
P		Ø3.5x12mm	Screw	68 pcs
Q		Ø6x14mm	Bolt	12 pcs
R		M 4	Allen Wrench	1 pc
S		Ø6x50mm	Screw	13 pcs
T		Ø15x9mm	Small cam lock	22 pcs

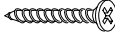

Philips head screwdriver required for assembly
(not included)

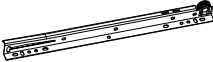
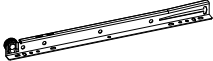
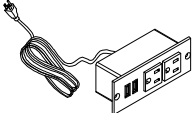
Hardware List

U			Plastic pivot	2 pcs
V			magnetic Catch latch	1 pc
W		Ø3x15mm	Screw	4 pcs
X			Hinge	1 pc
Y			Hinge	1 pc
Z			strike plate	1 pc
AA		Ø6x25mm	Bolt	24 pcs
BB		Ø4x38mm	Screw	24 pcs
CC		12"	Left Glide Track	3 pcs
DD		12"	Right Glide Track	3 pcs
EE		12"	Left Glide Runner	3 pcs
FF		12"	Right Glide Runner	3 pcs
GG			USB Interface	1 pc
HH			Tipping Restraint Hardware	2 sets
JJ			Power plug	1 pc

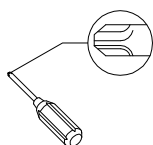

Philips head screwdriver required for assembly
(not included)

Step 1

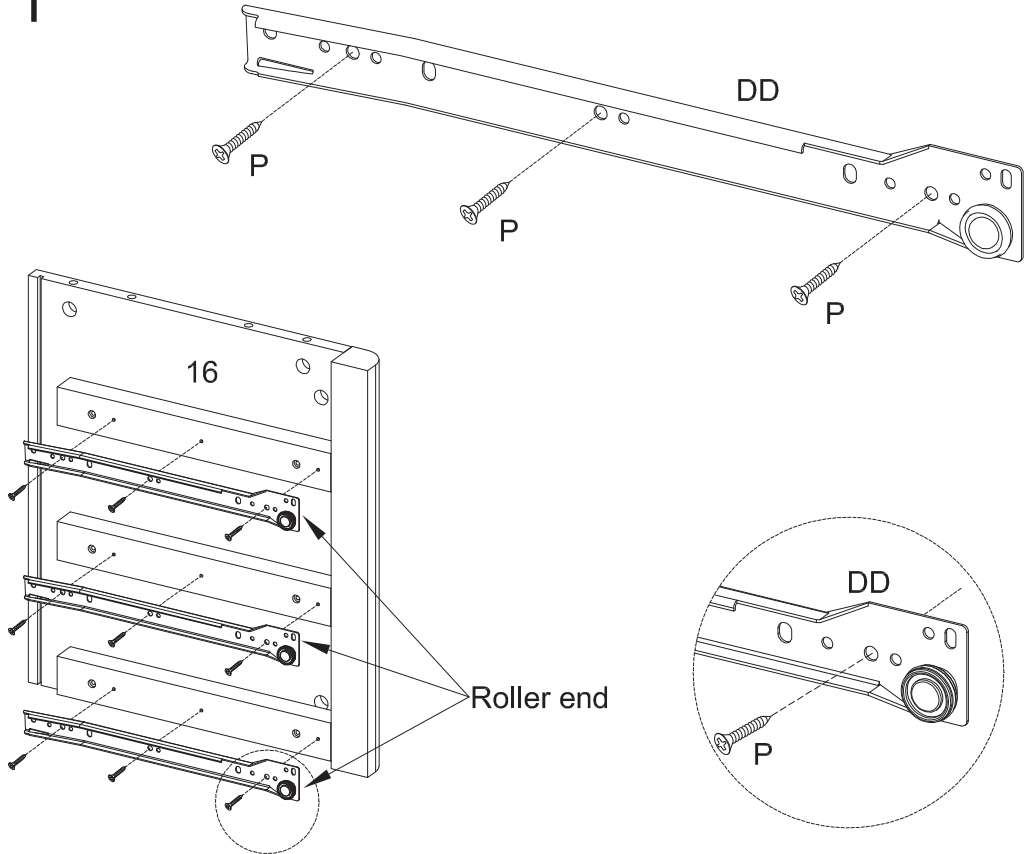

Step 2

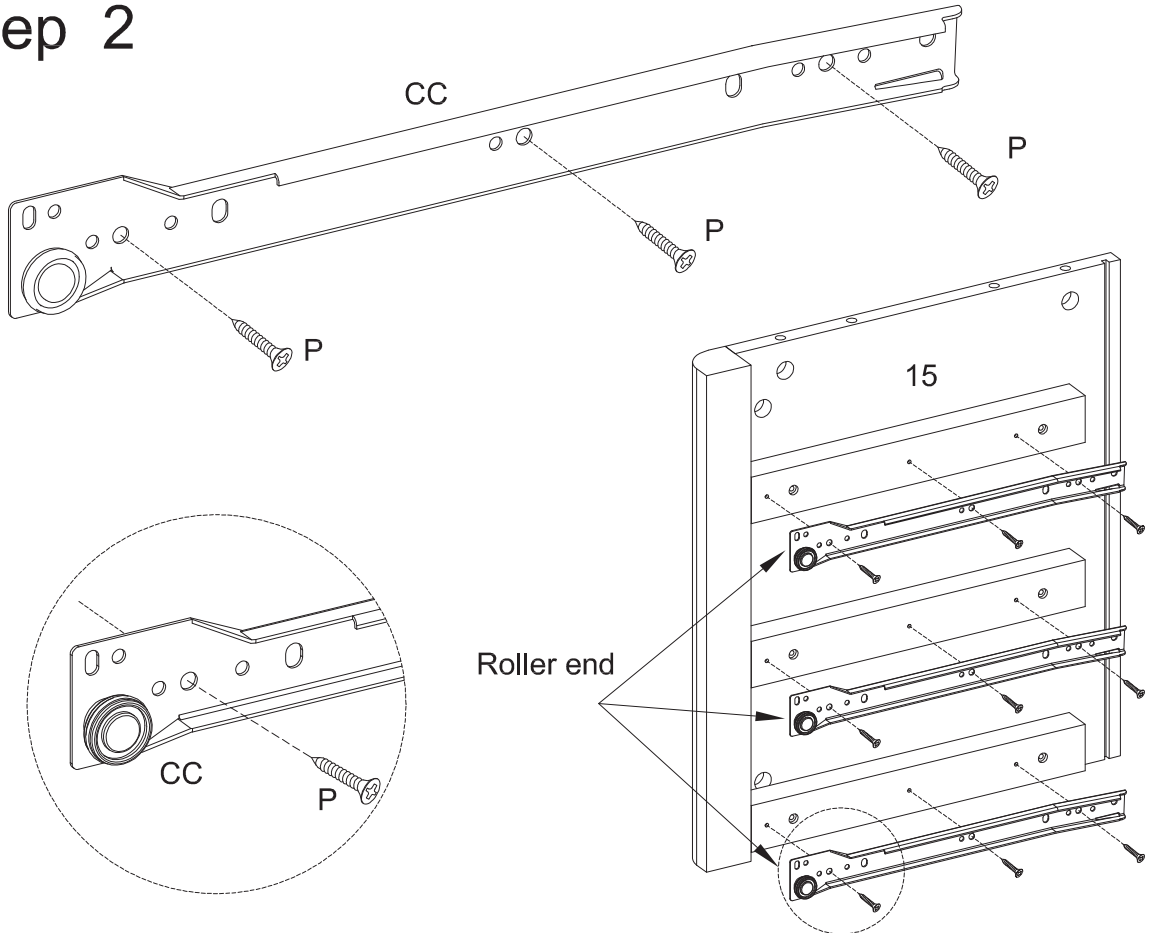

Step 3

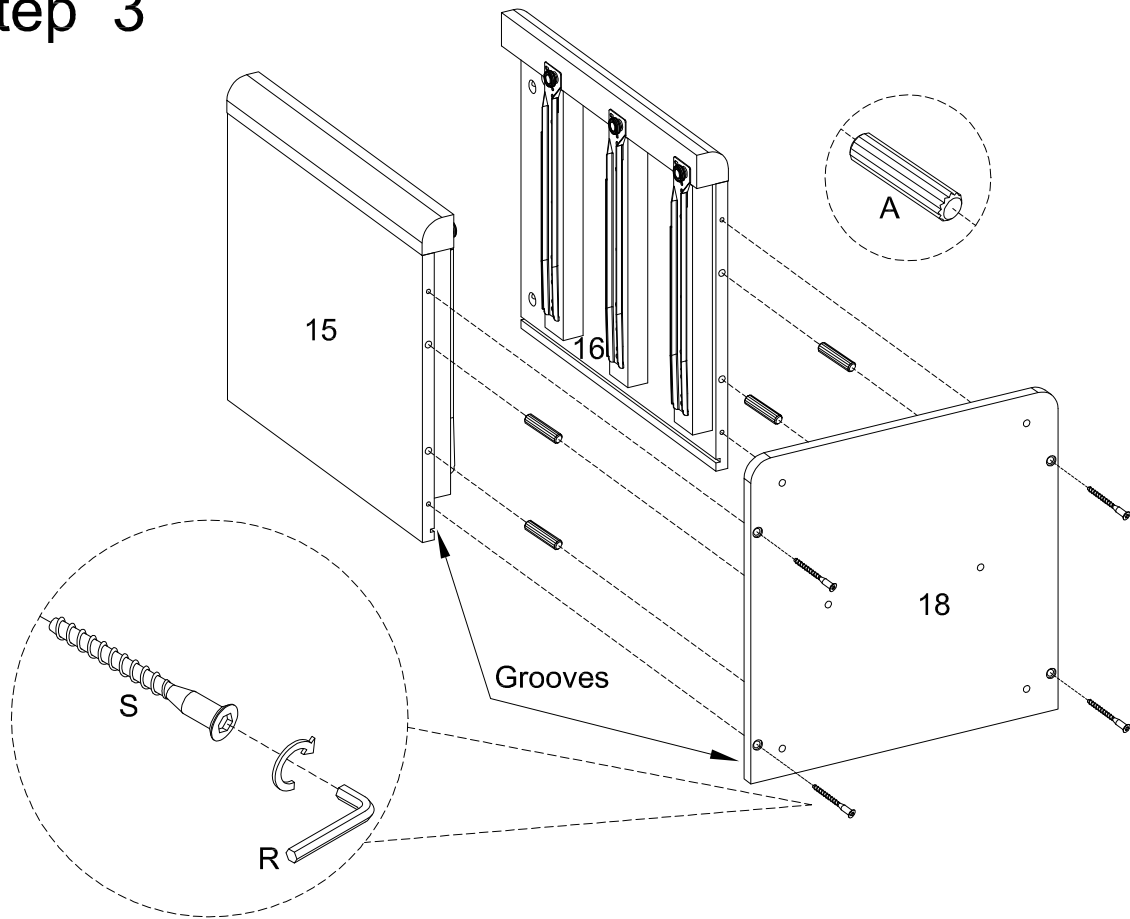

Step 4

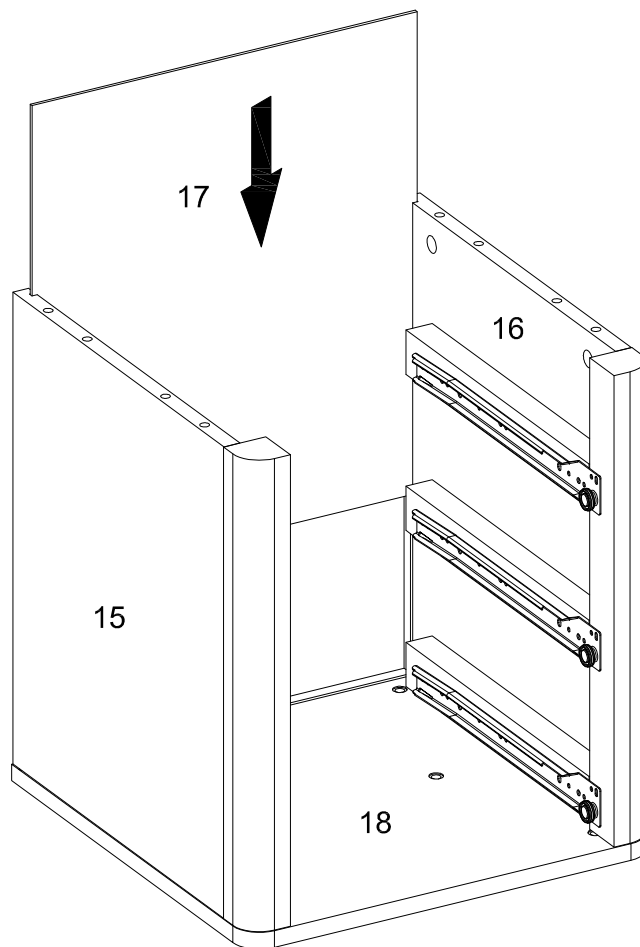

Step 5

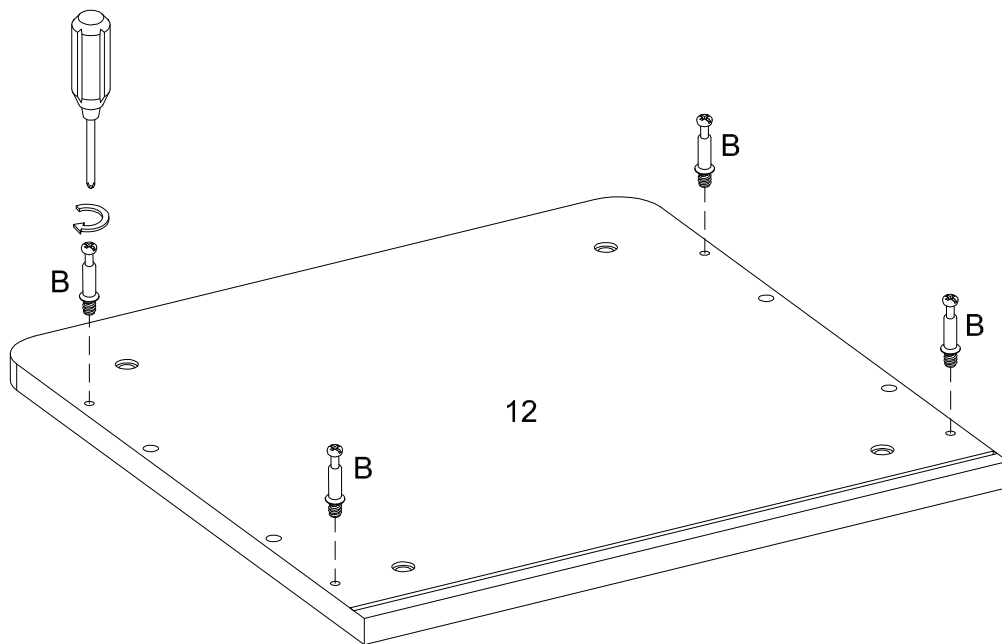

Step 6

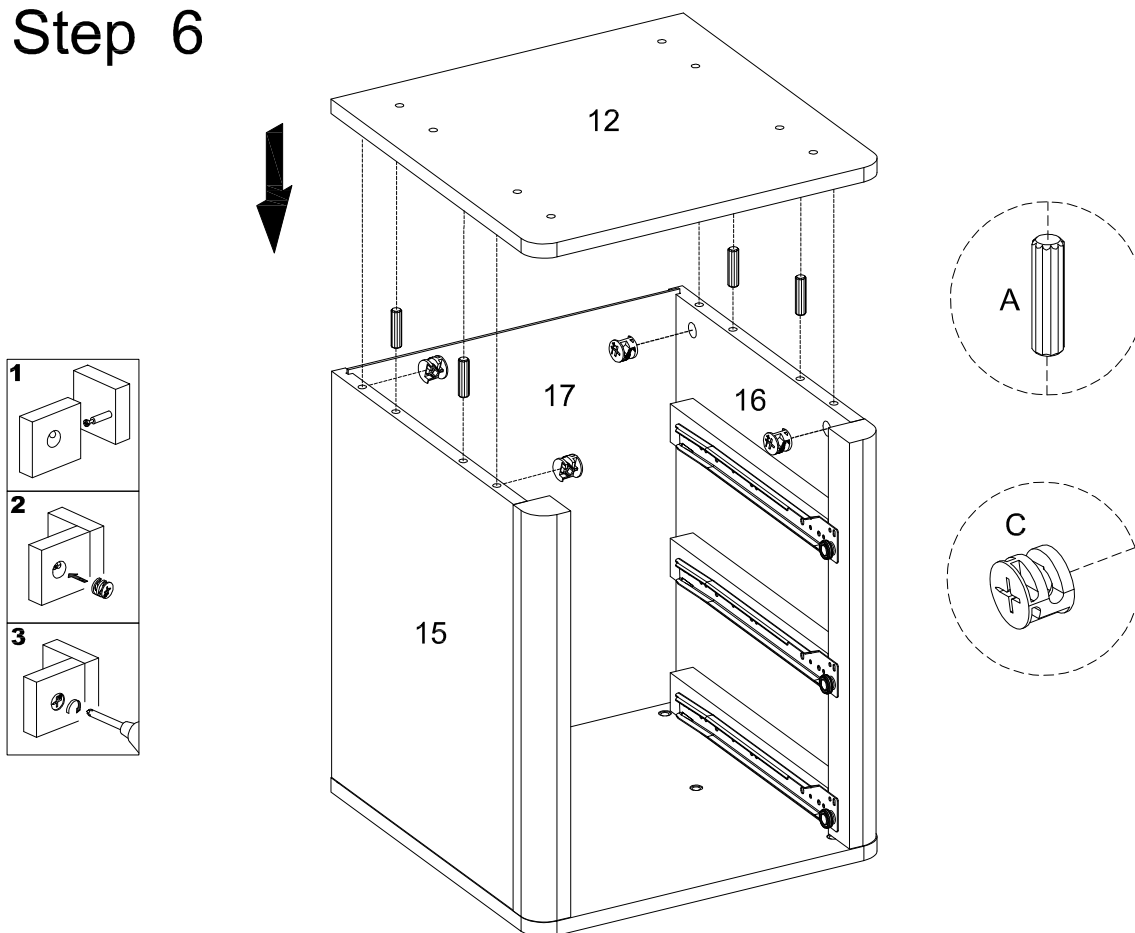

Step 7

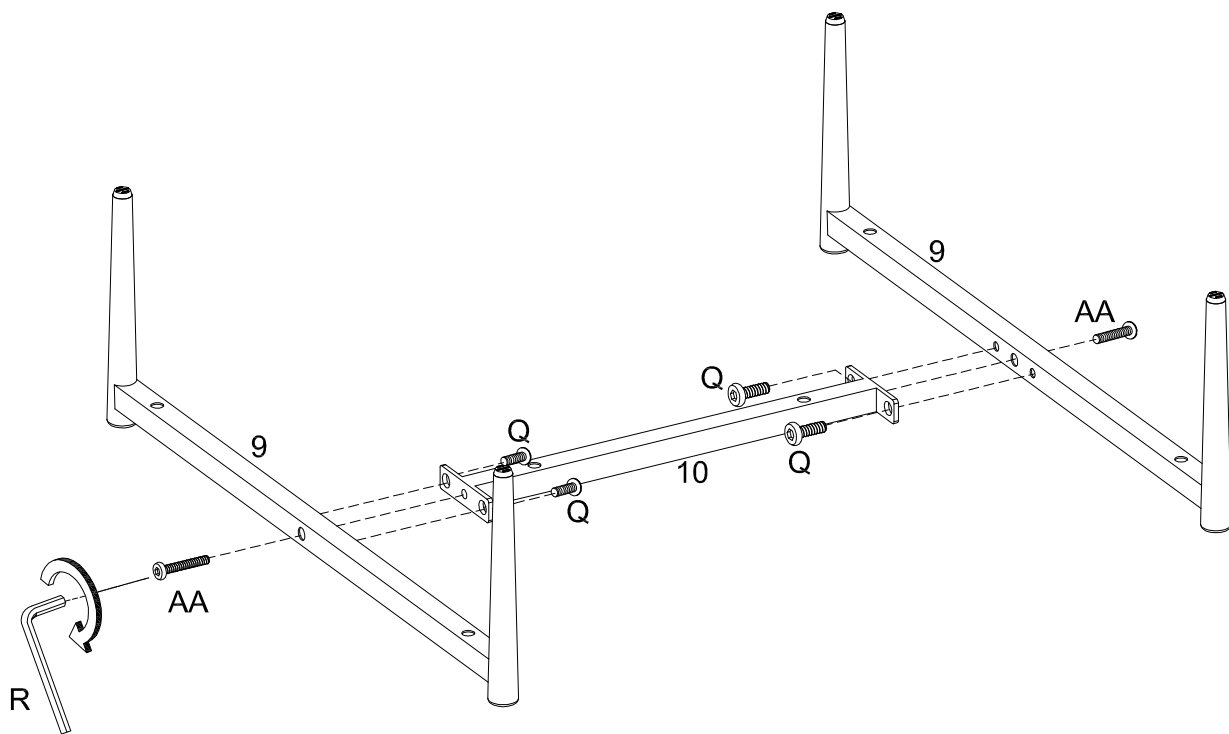

Note: Do not fully tighten the bolts.

Step 8

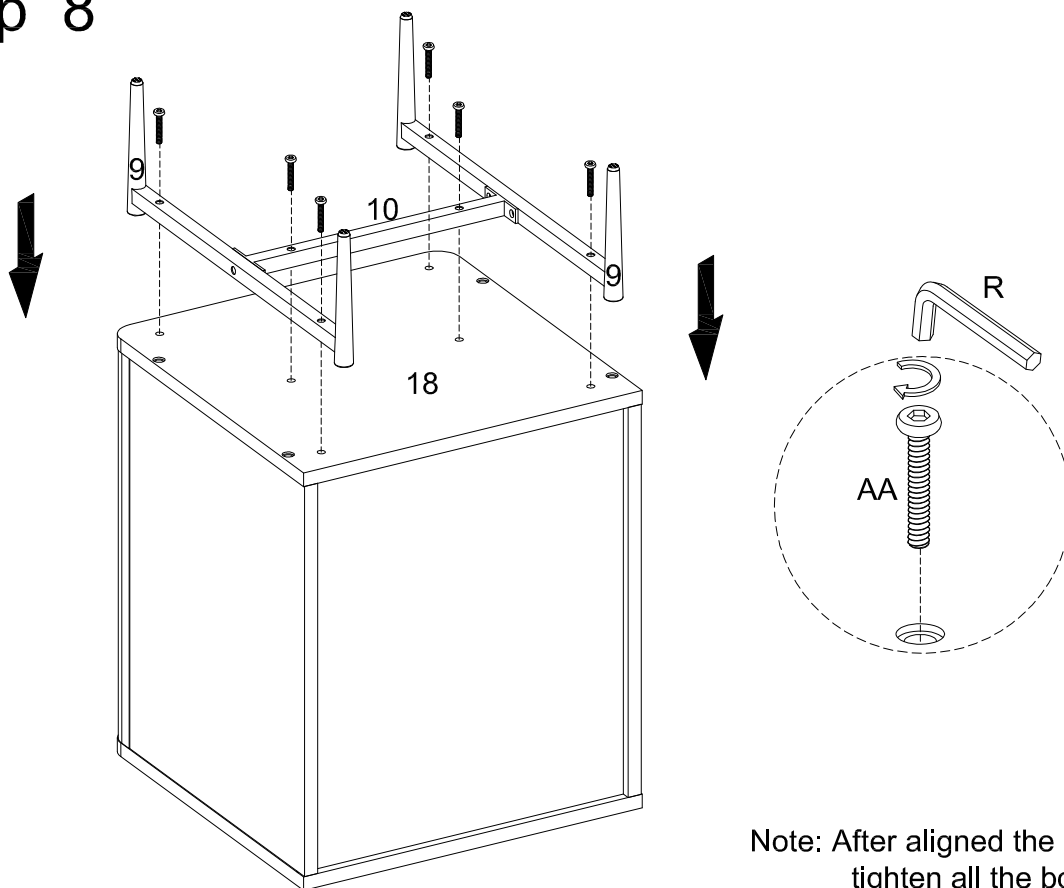

Note: After aligned the bolts, then tighten all the bolts.

Step 9

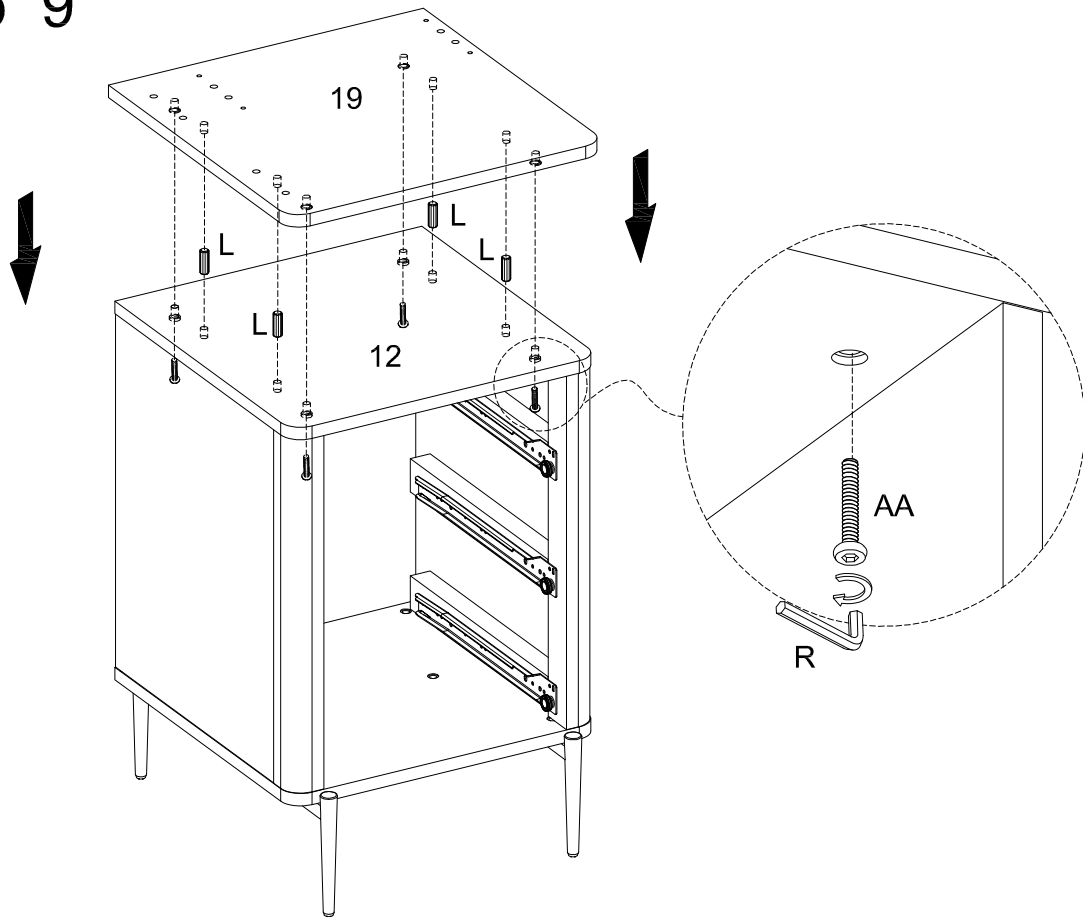

Step 10

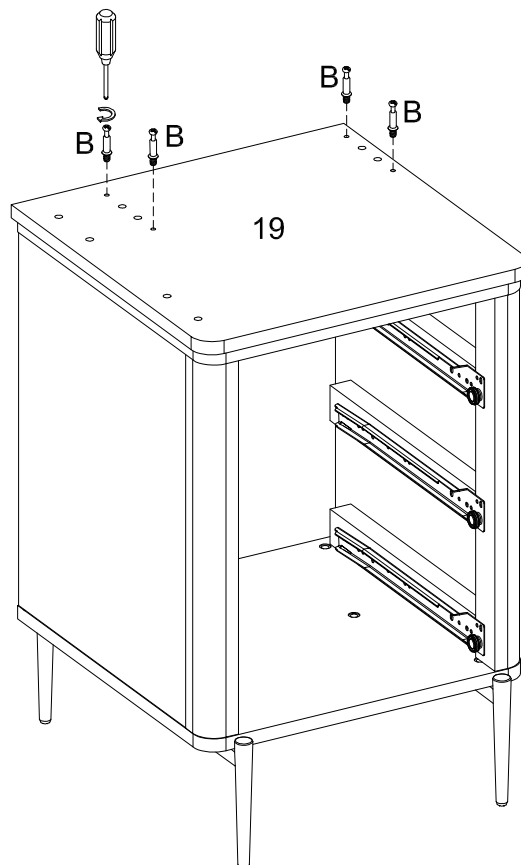

Step 11

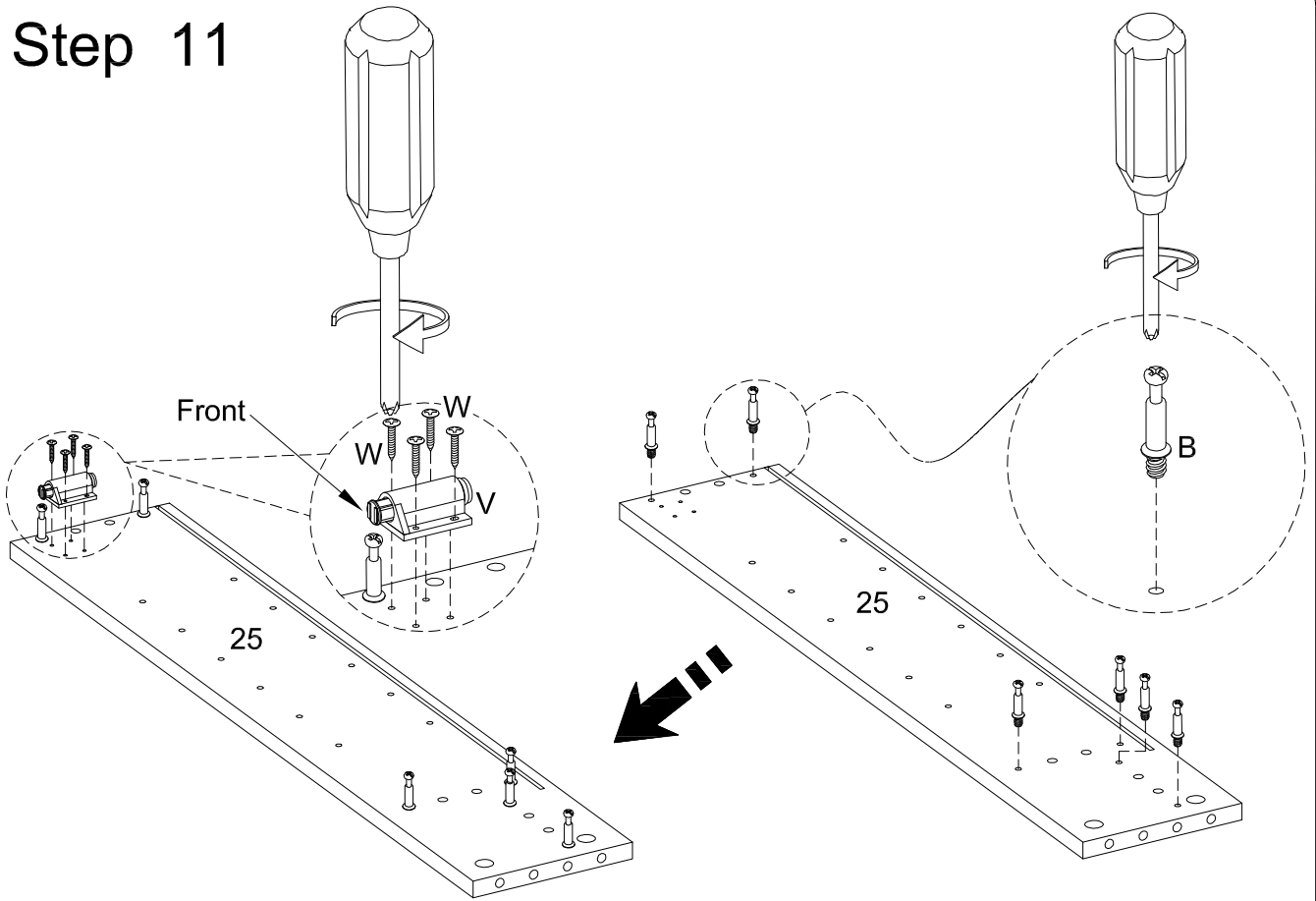

Step 12

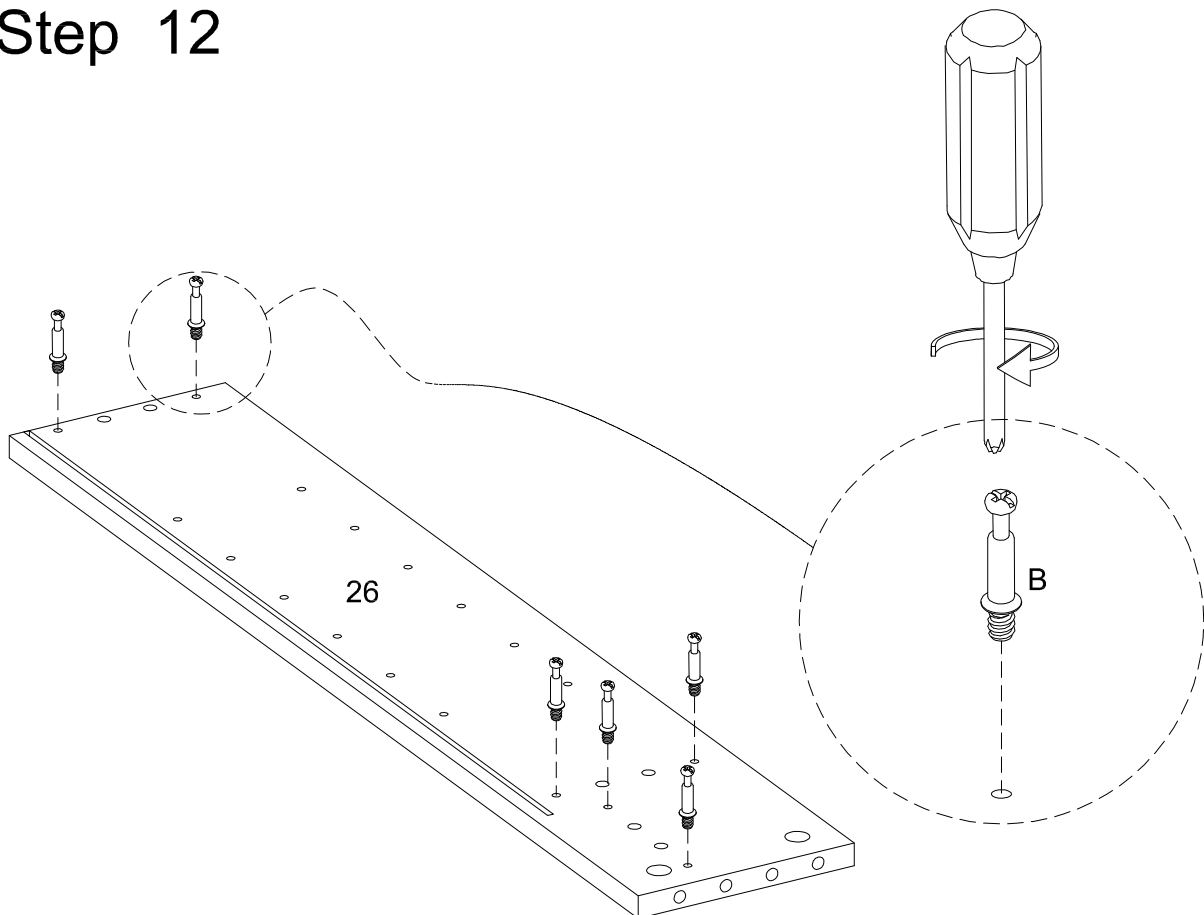

Step 13

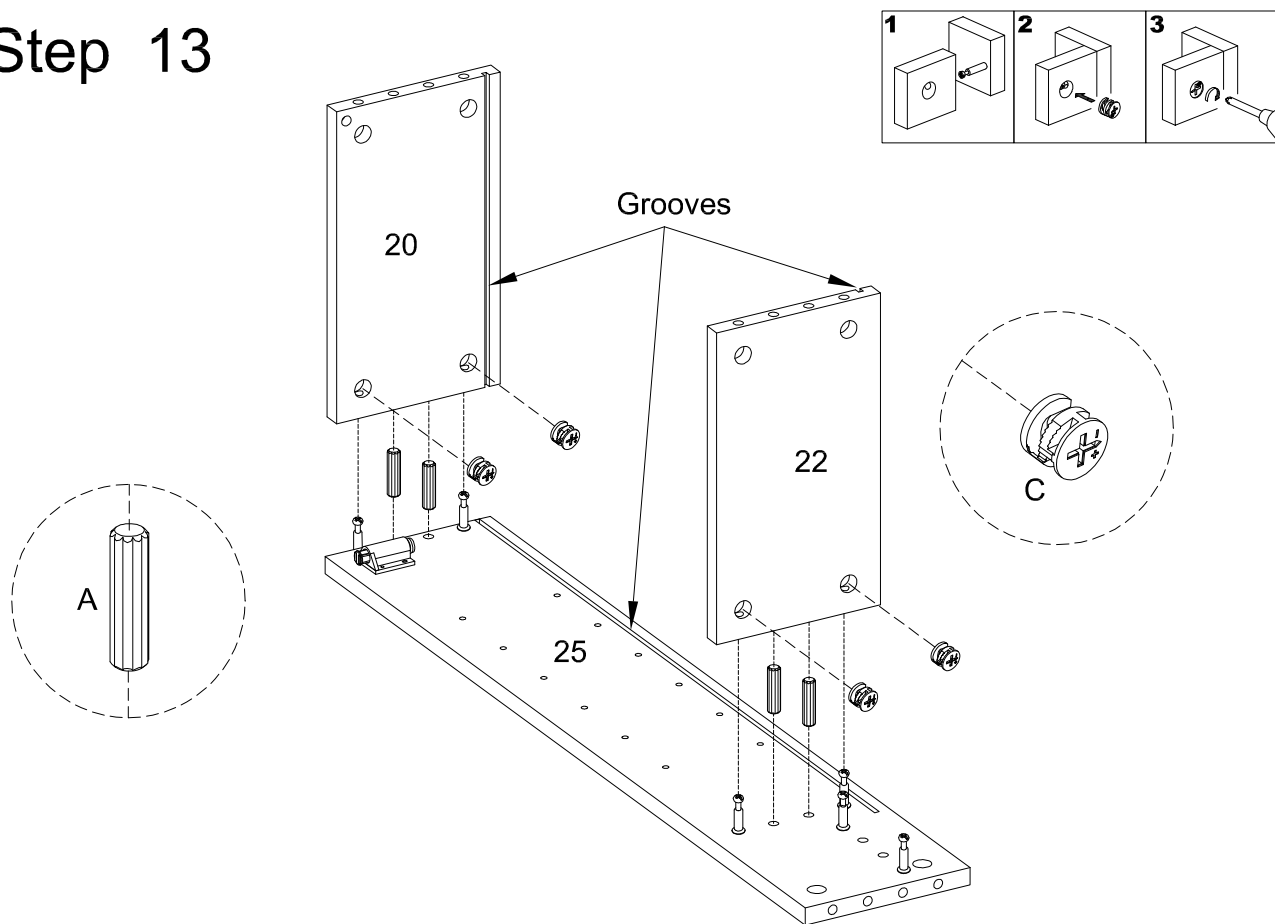

Step 14

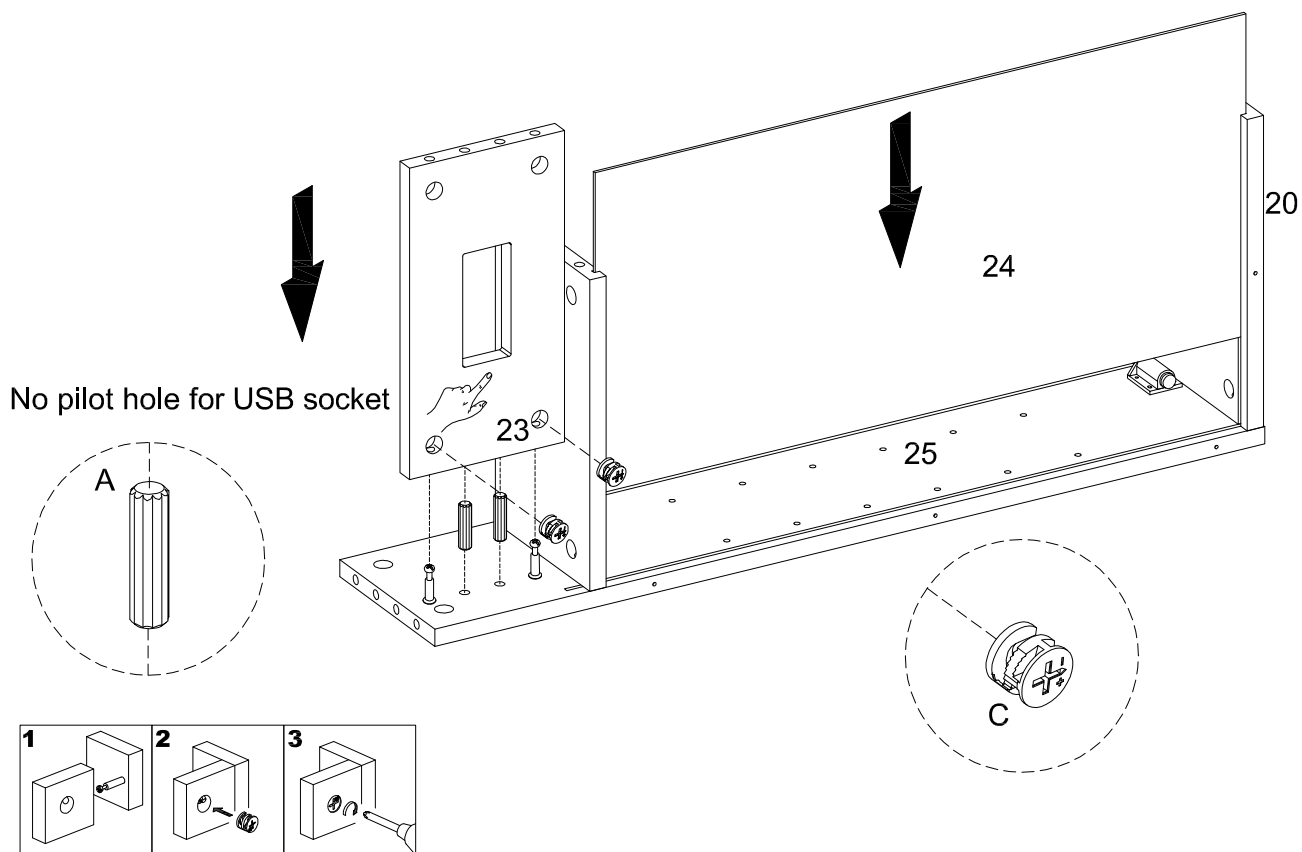

Step 15

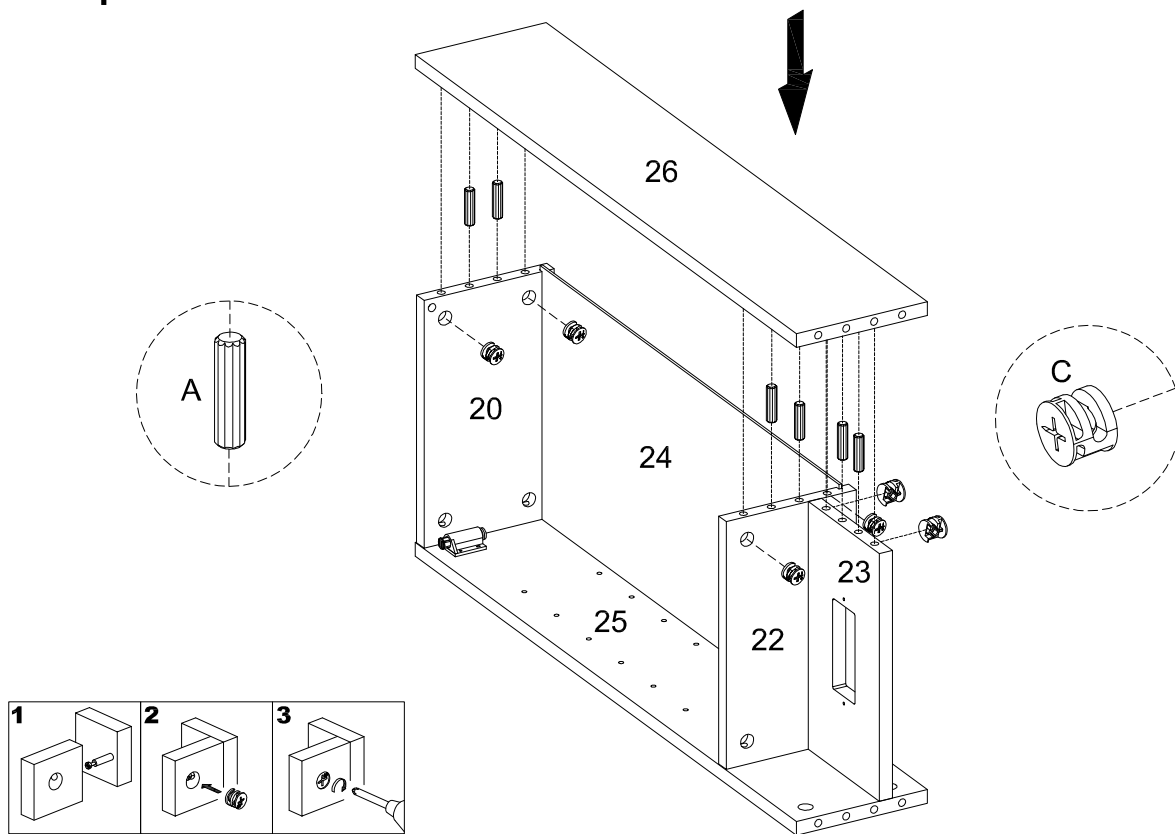

Step 16

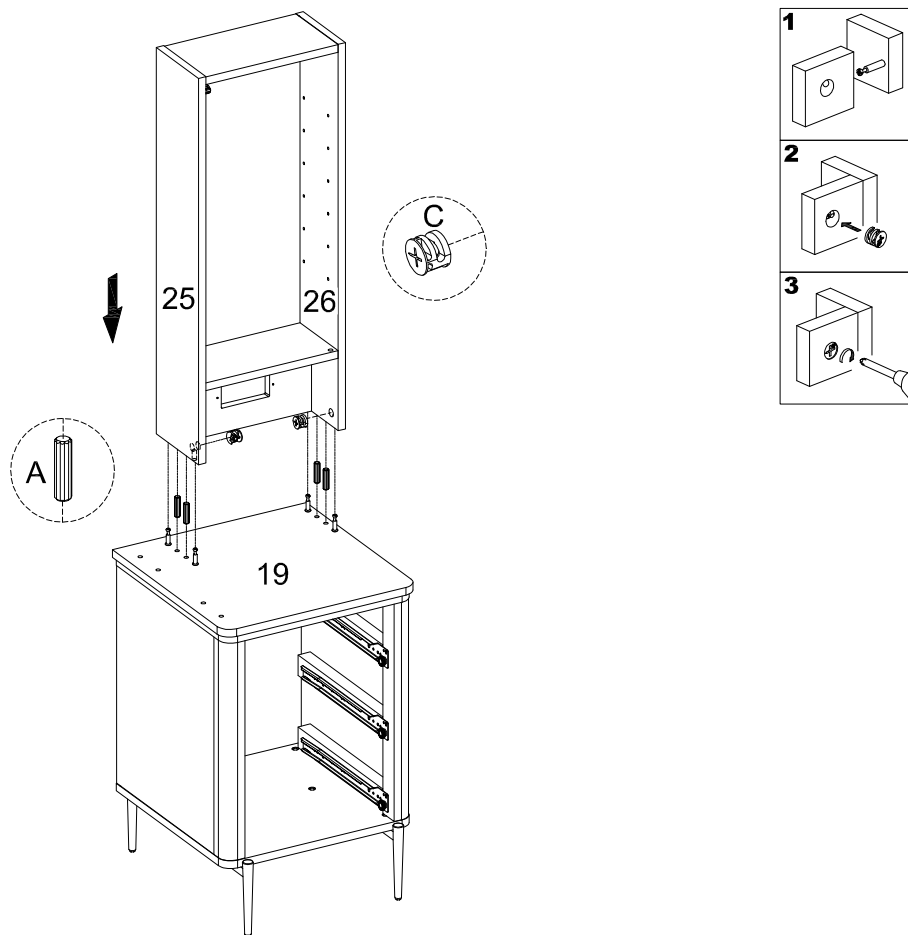

Step 17

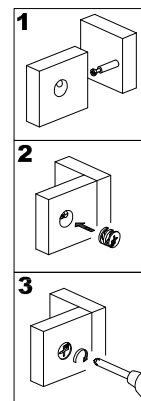
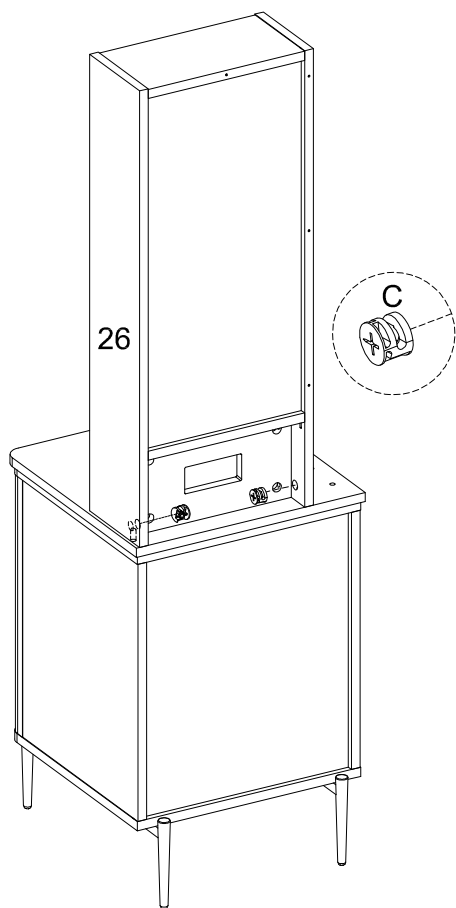

Step 18

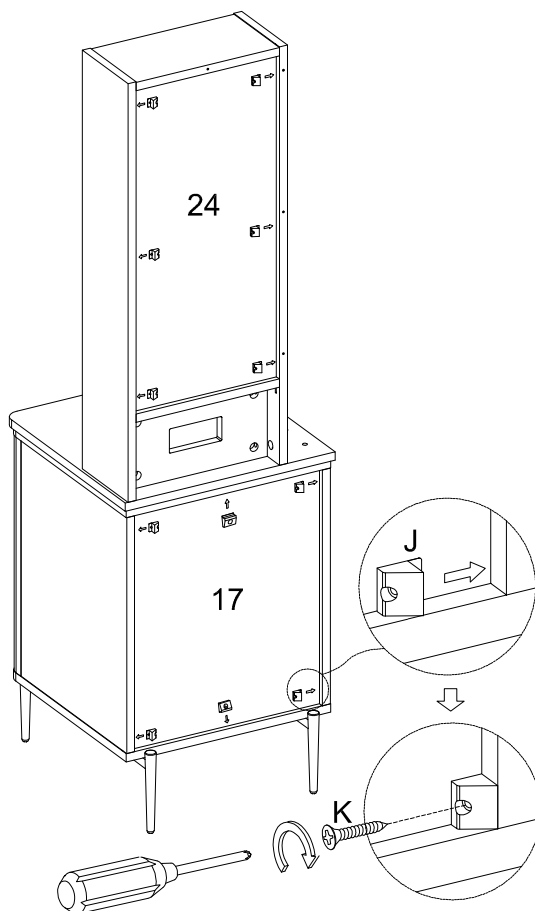

Step 19

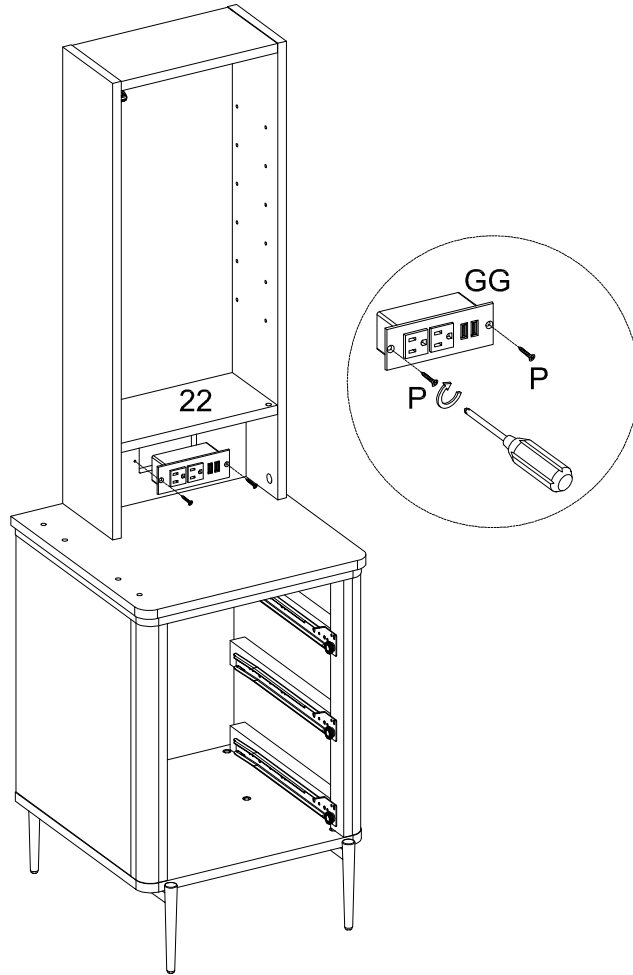

Step 20

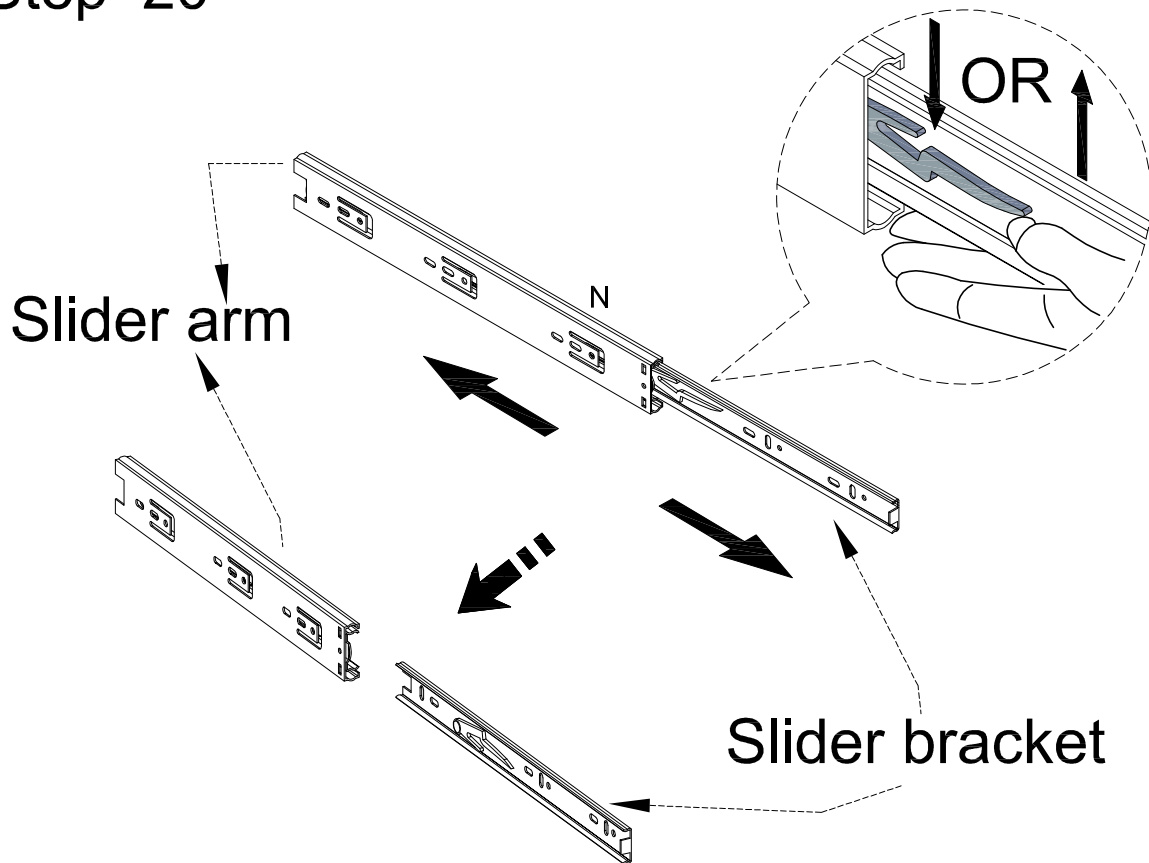

Step 21

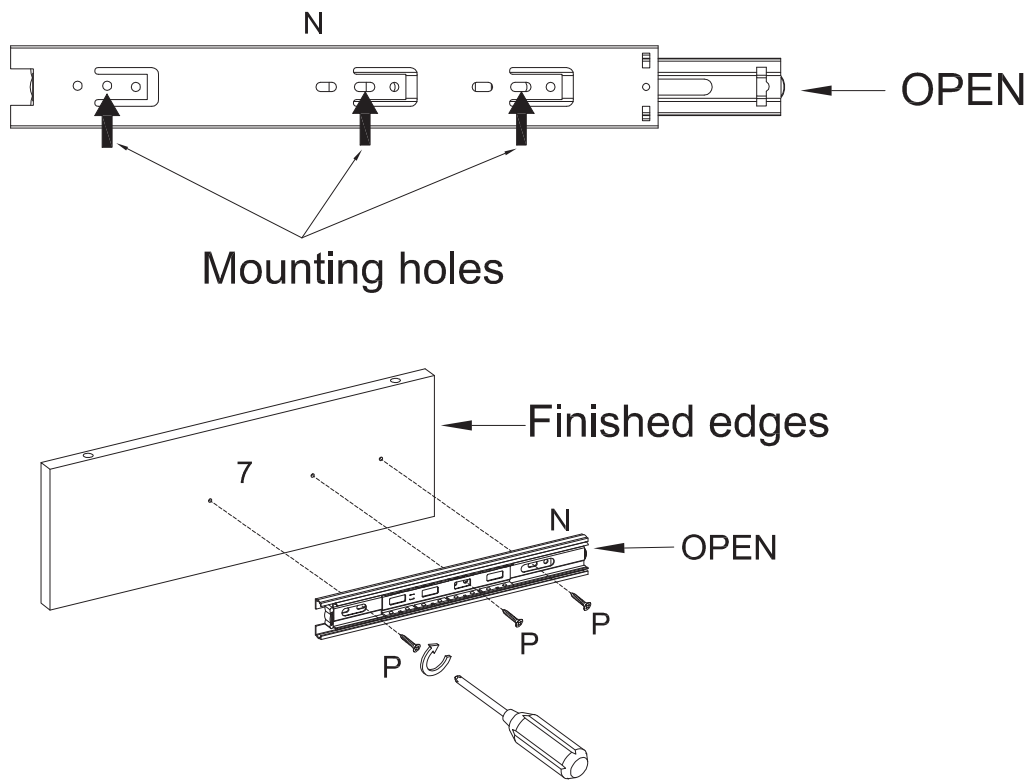

Step 22

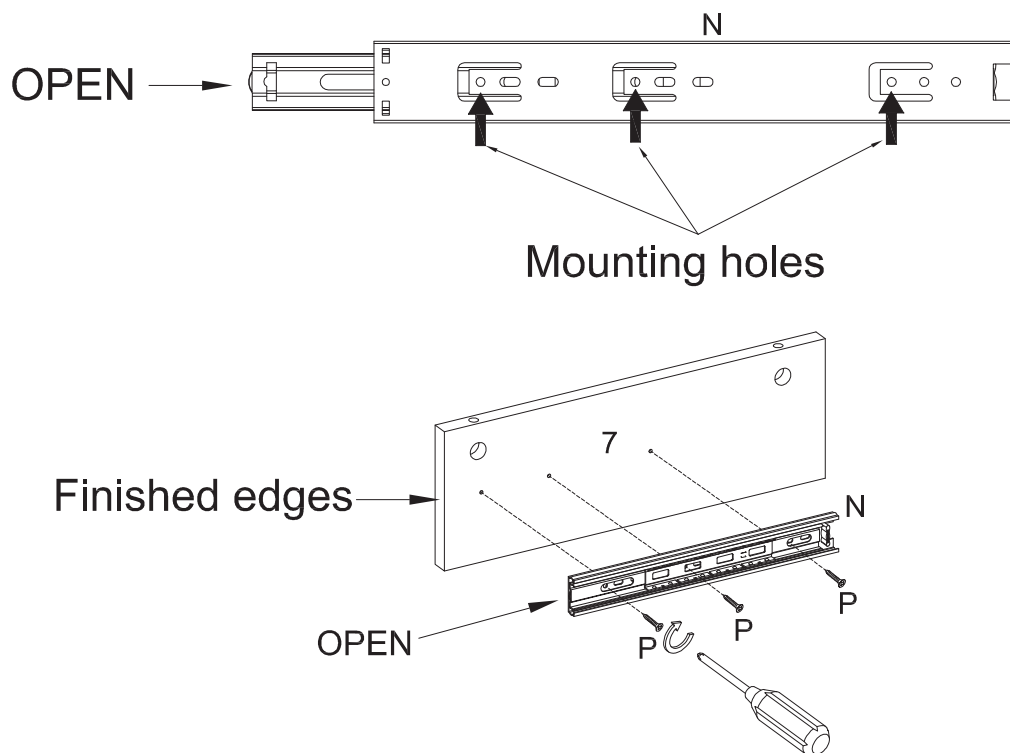

Step 23

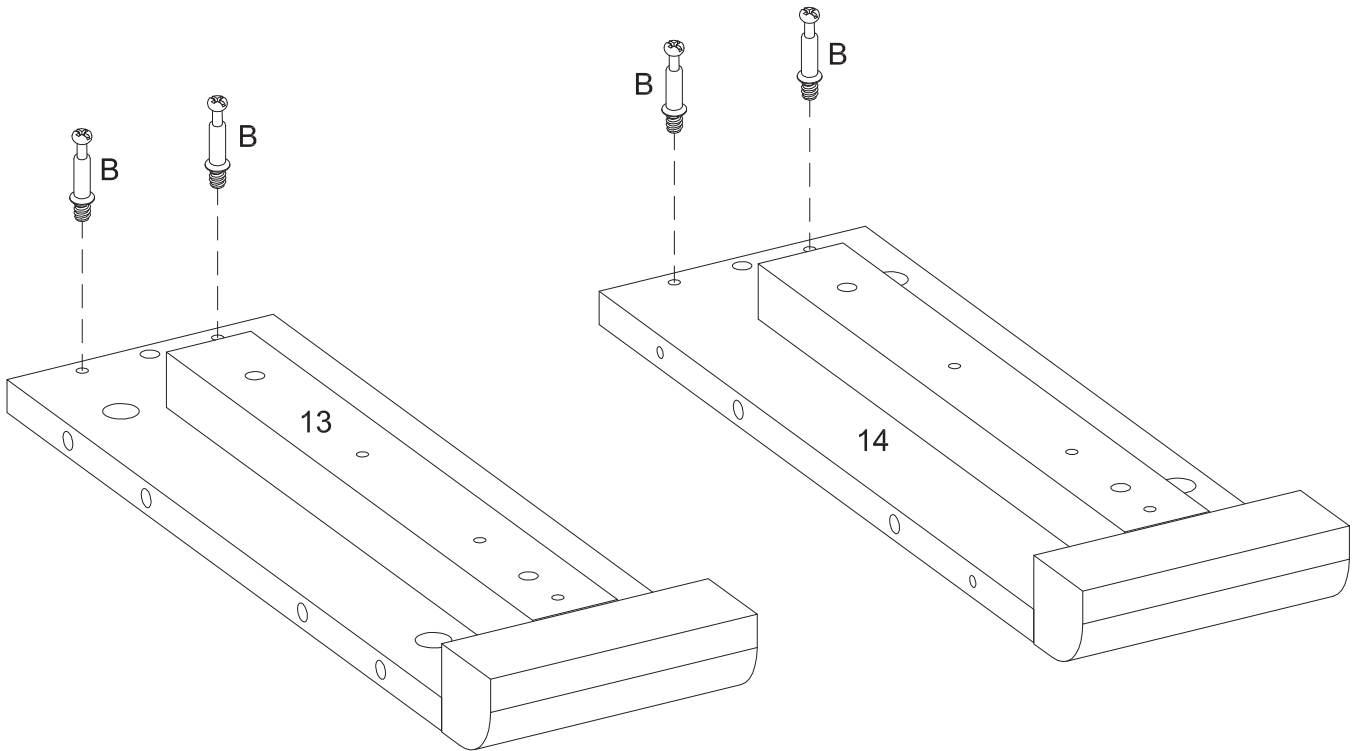

Step 24

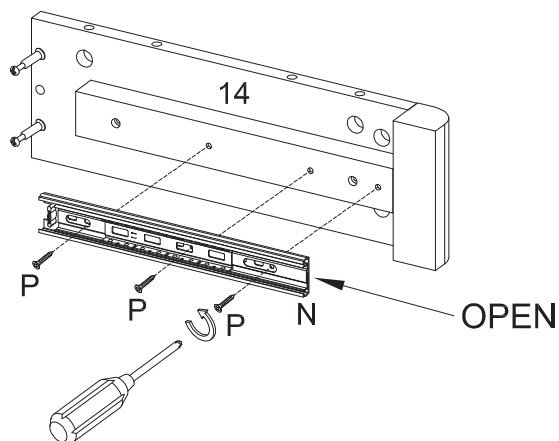
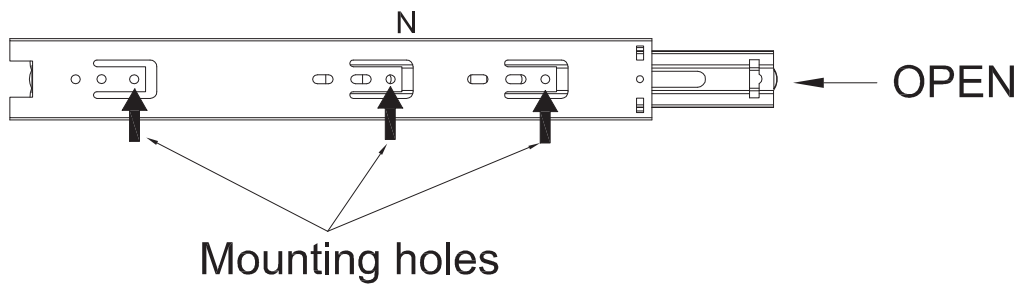

Step 25

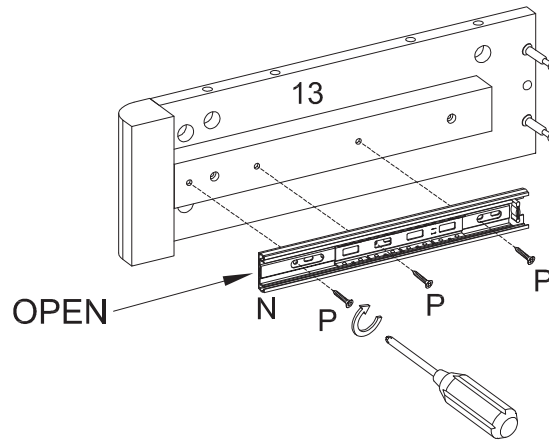
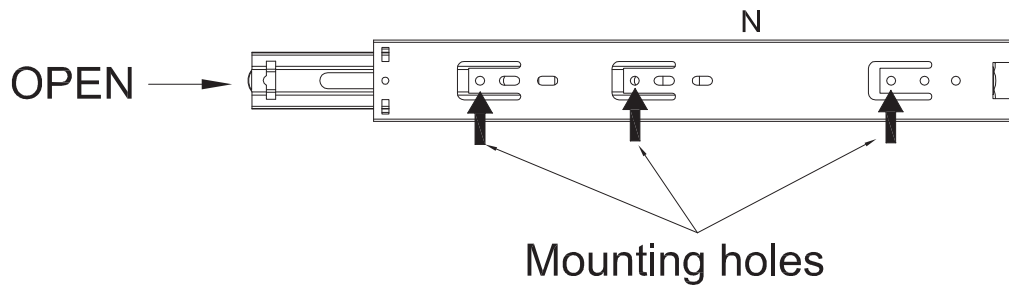

Step 26

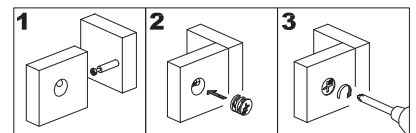
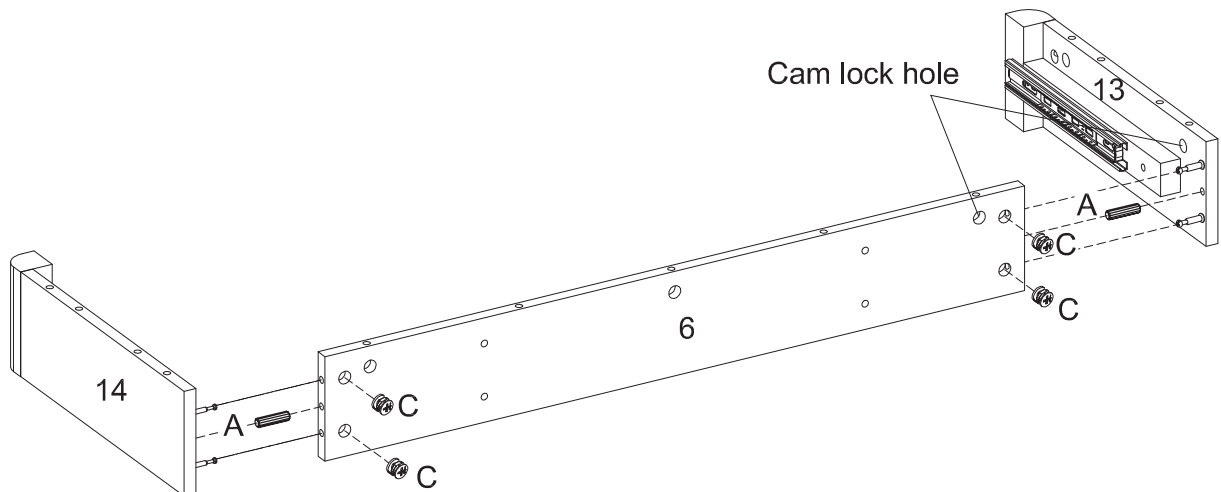

Step 27

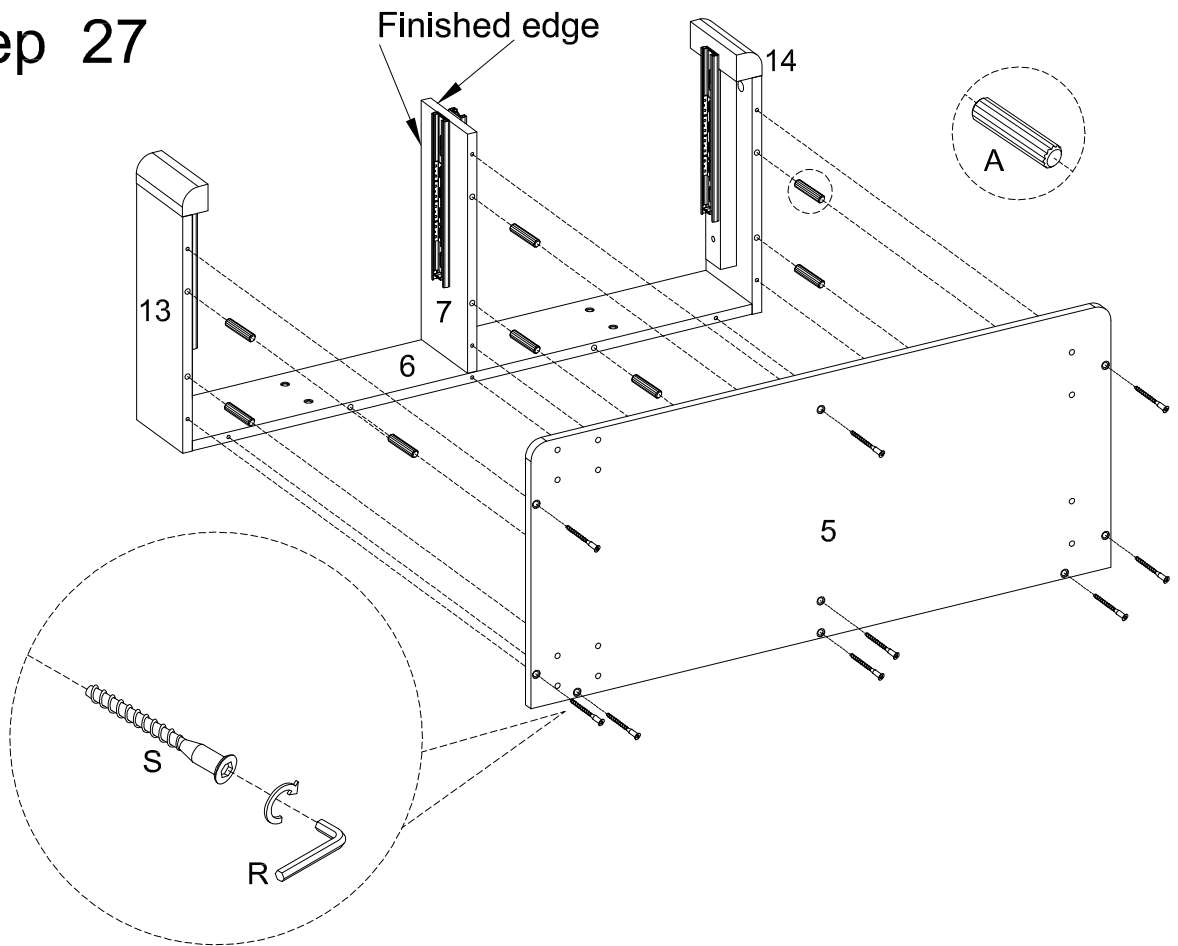

Step 28

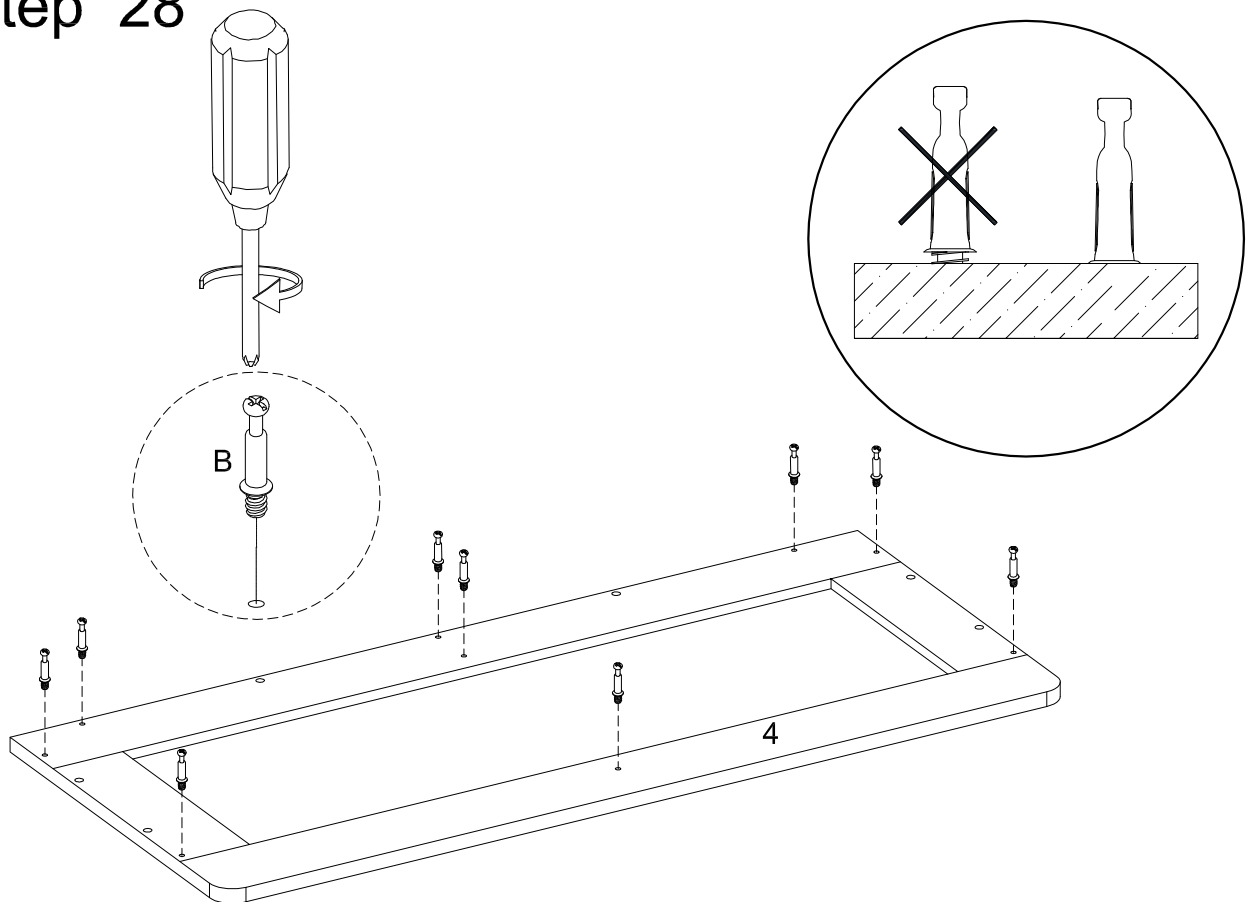

Step 29

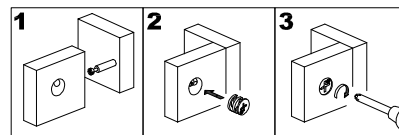
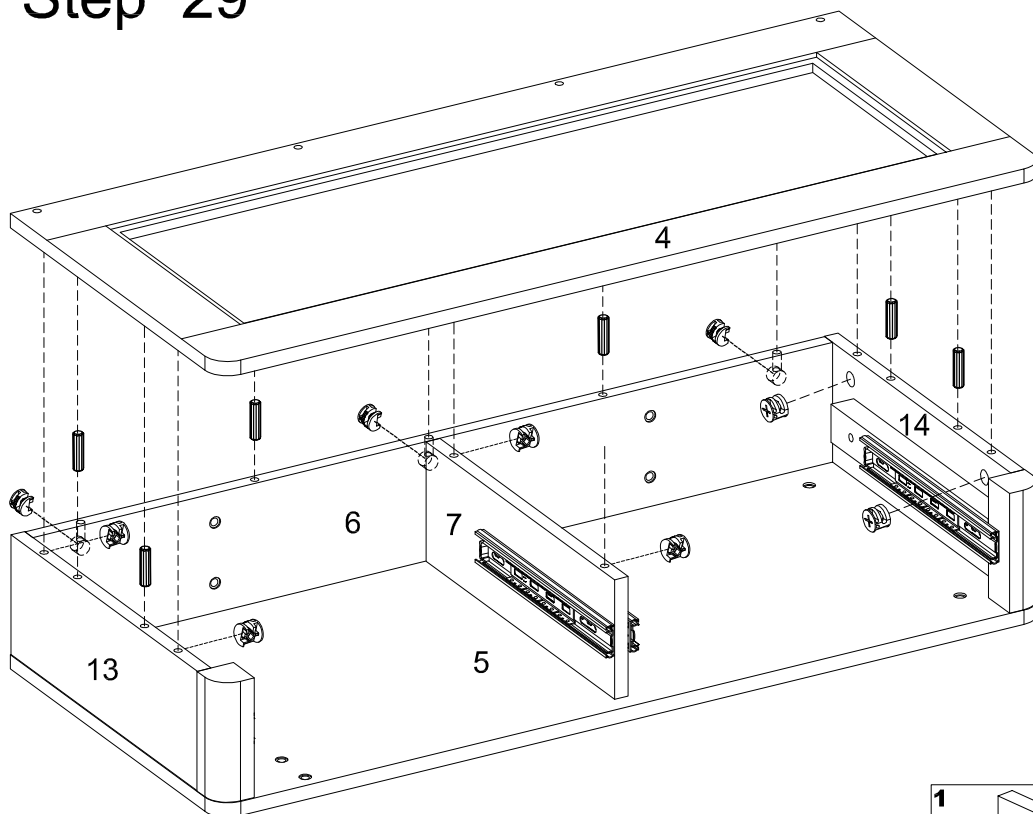

Step 30

Care the direction
of the leg

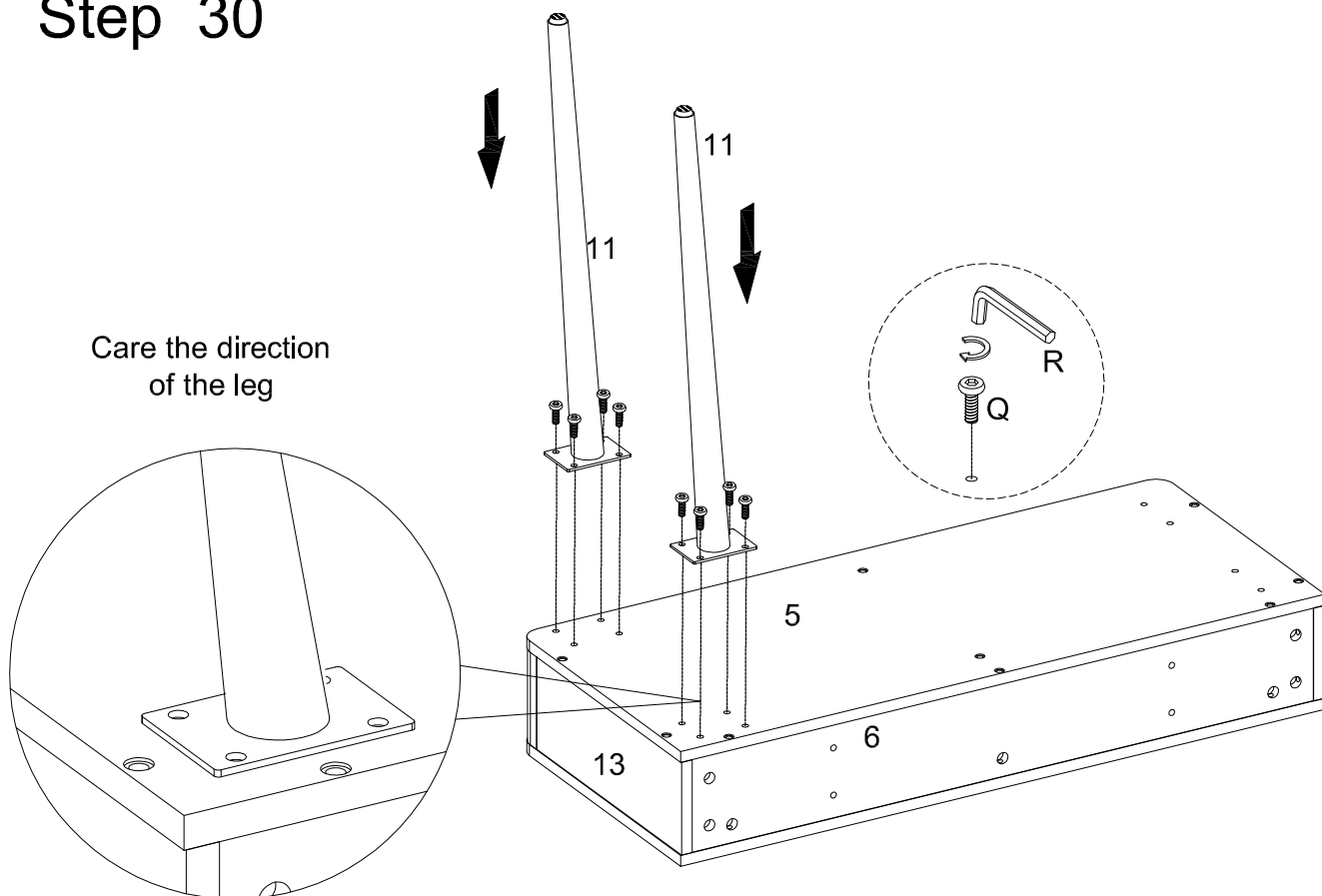

Step 31

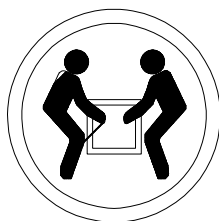
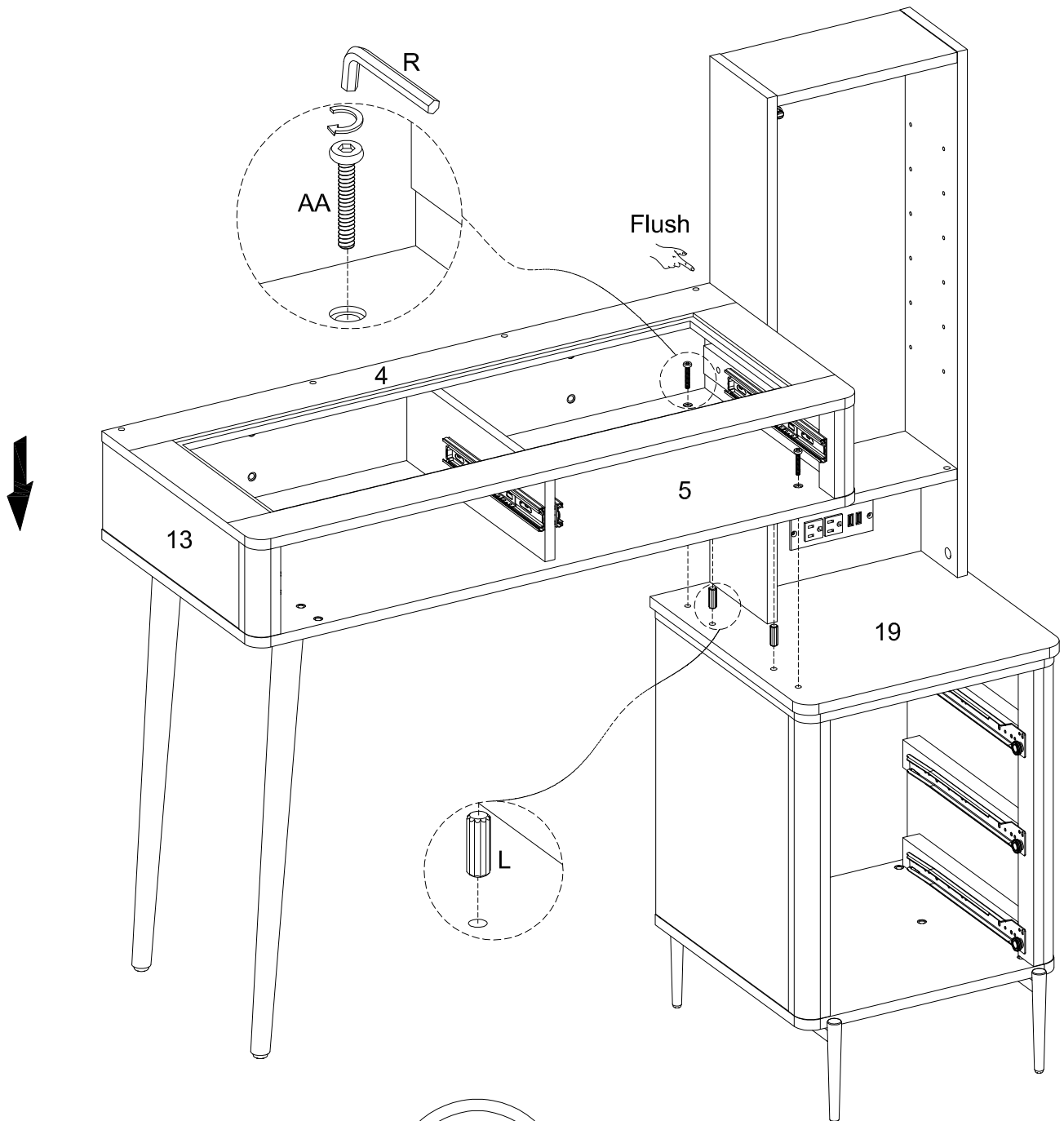

CAUTION: Heavy! You may need assistance with this step.

Step 32

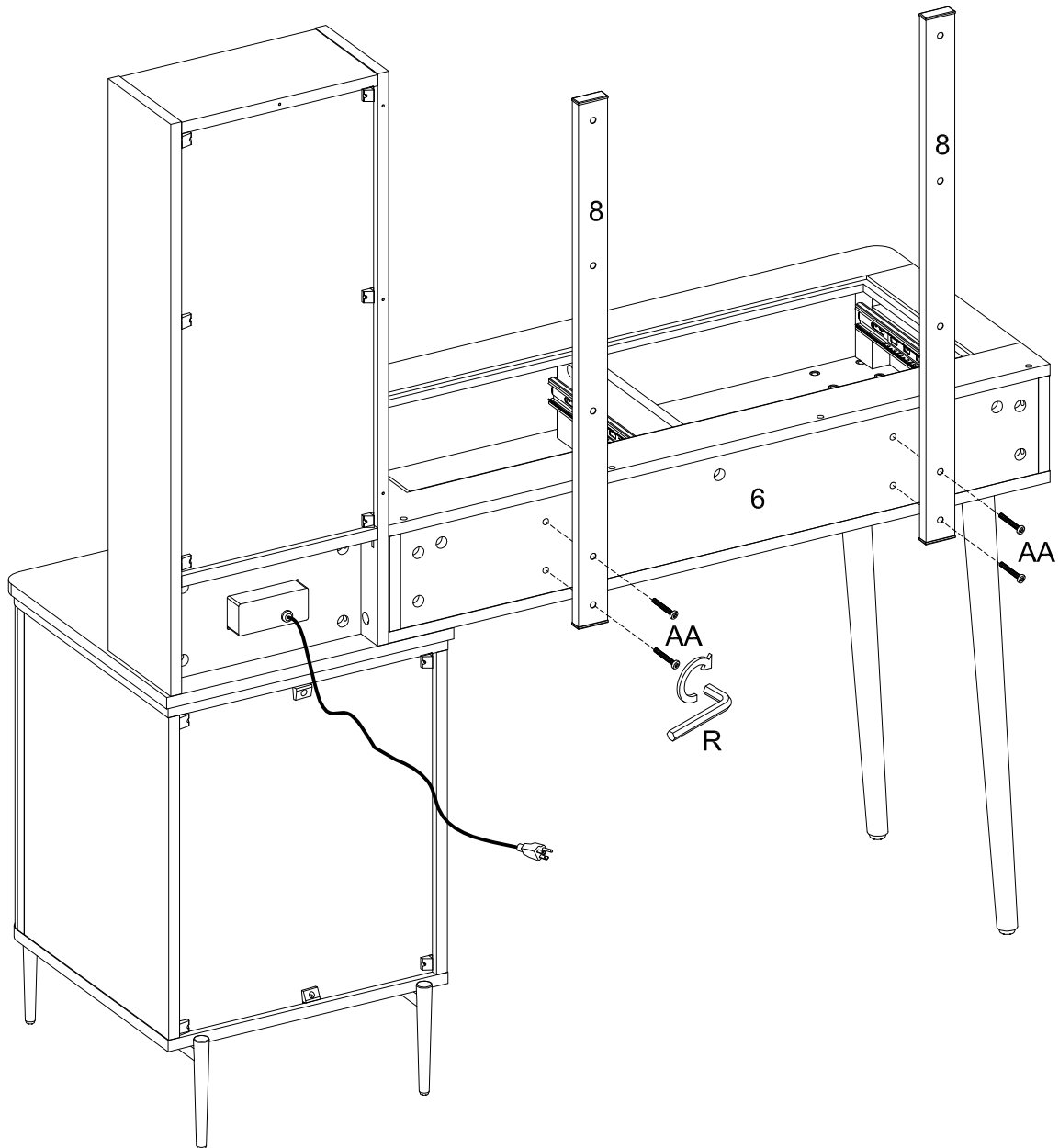

Note: Do not fully tighten bolt (AA) until aligned all bolts (including Step 34), This will help this metal tube (8) to be fixed easily.

Step 33

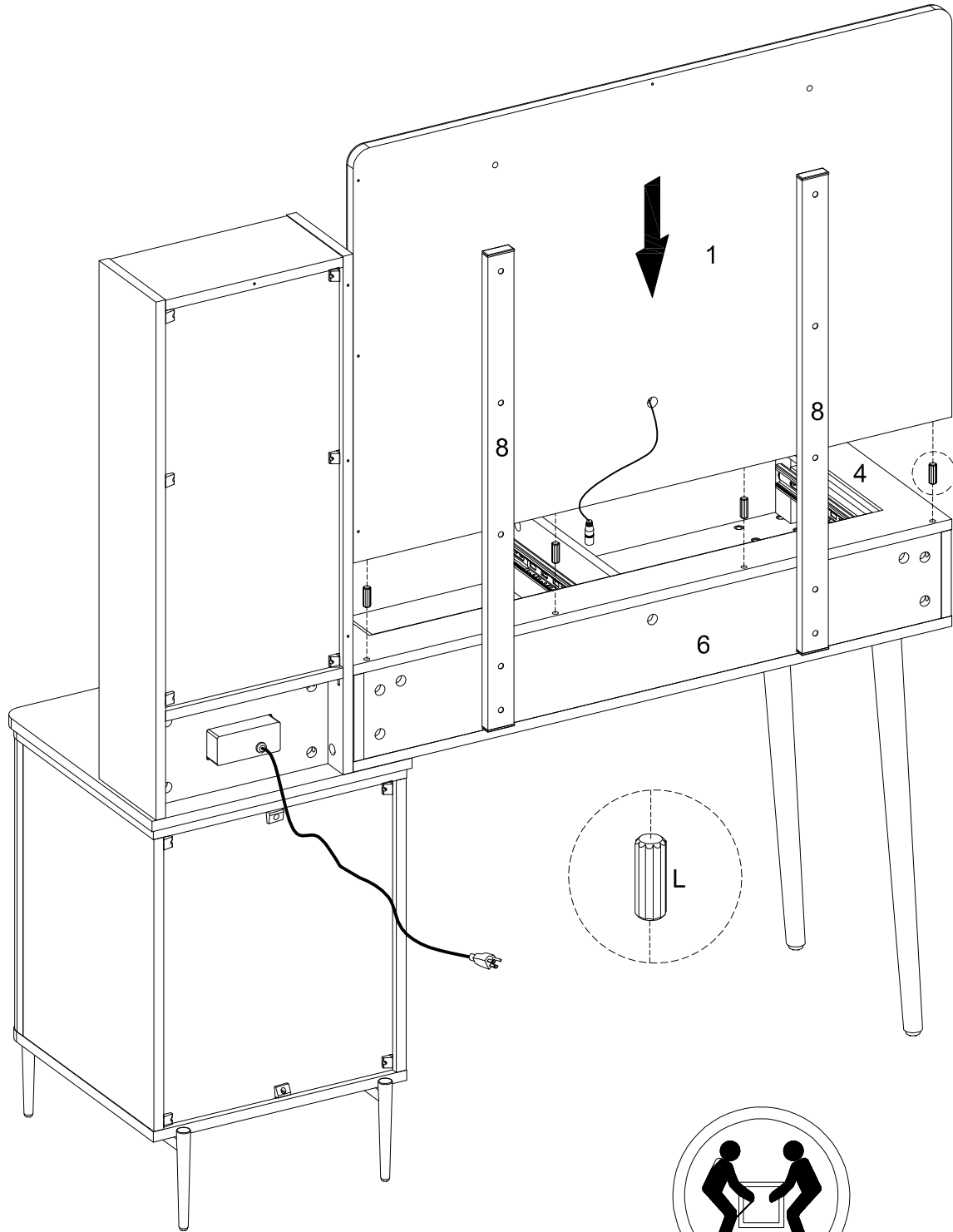

CAUTION: Heavy! You may need assistance with this step.

Step 34

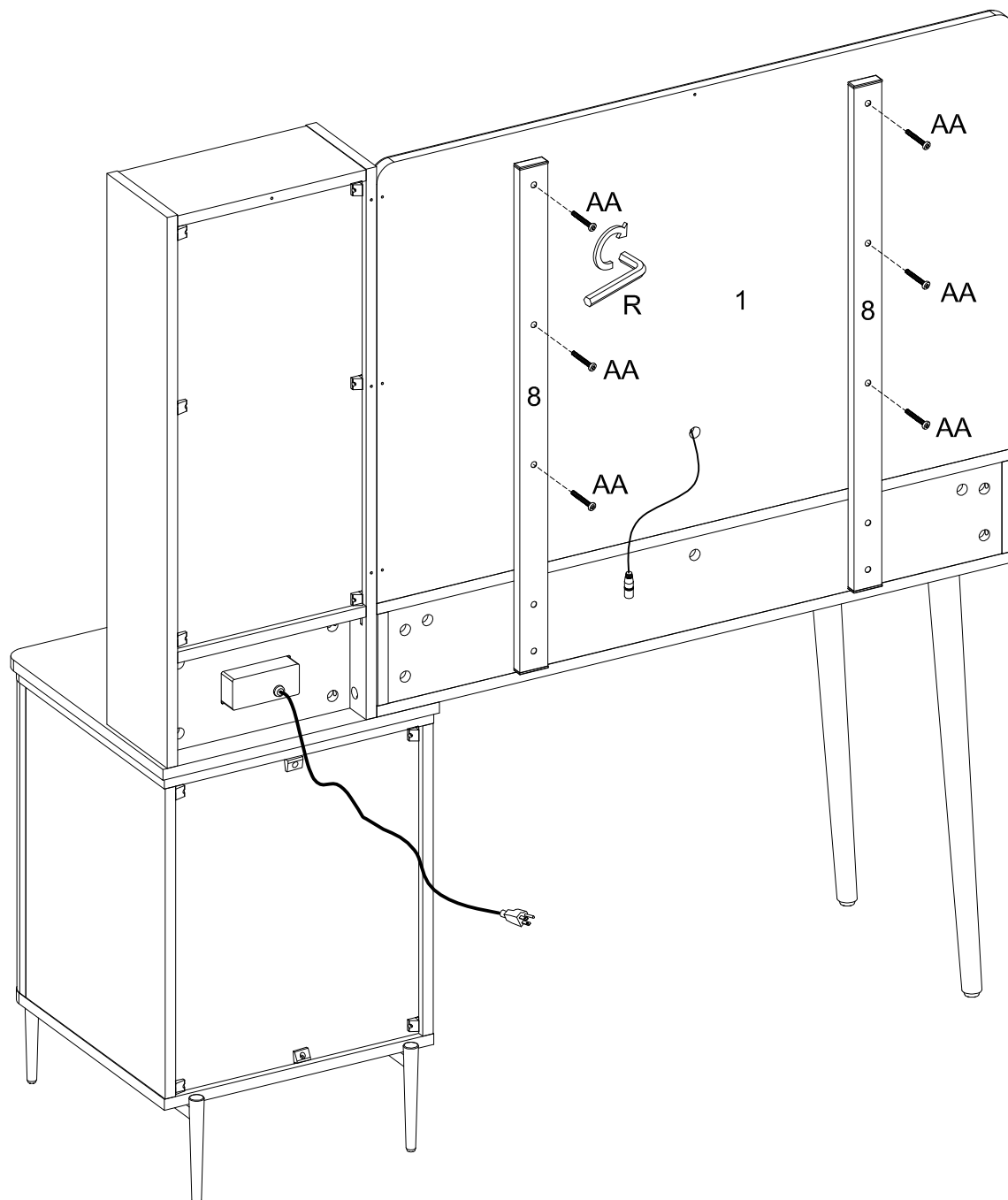

Step 35

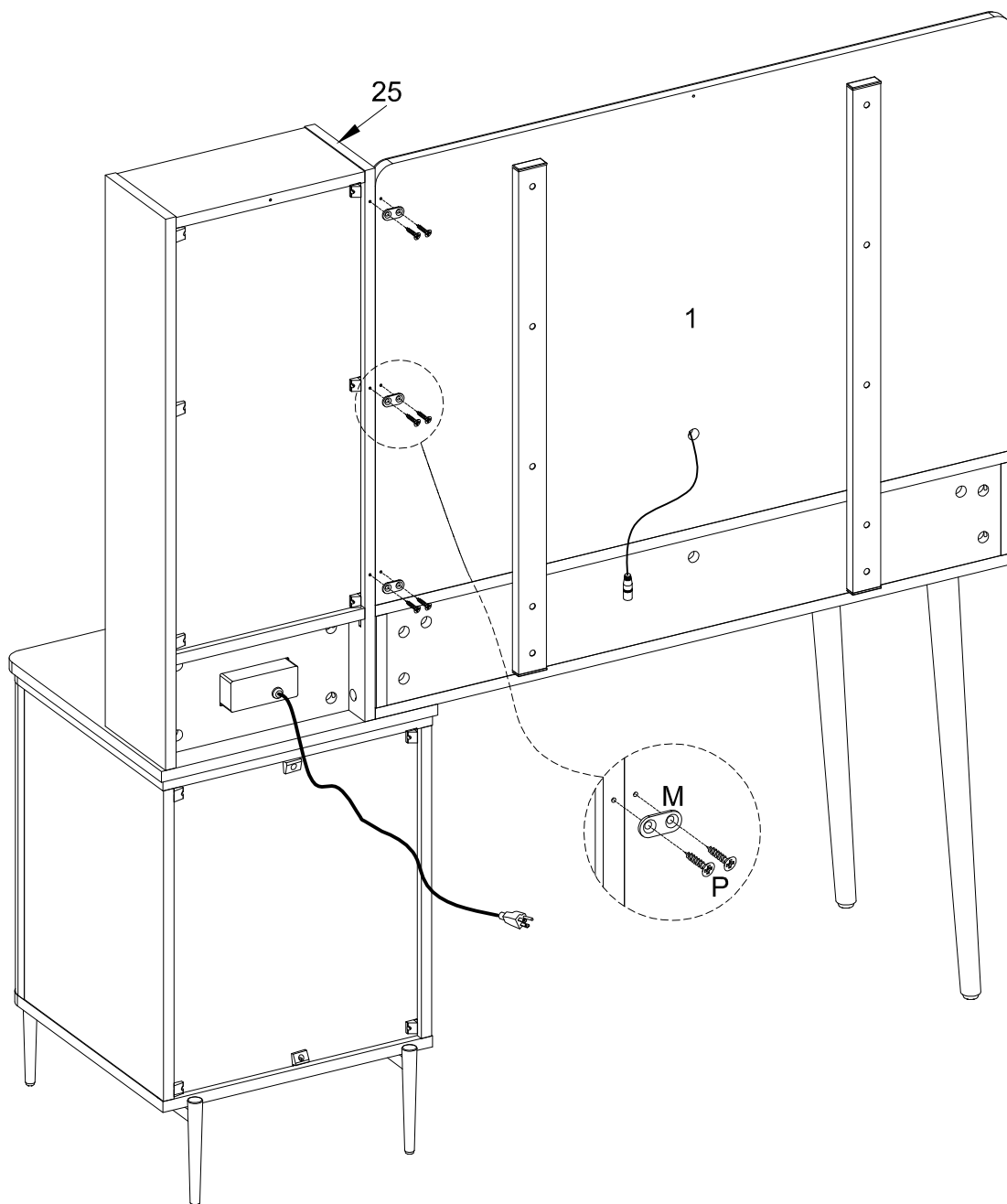

Step 36

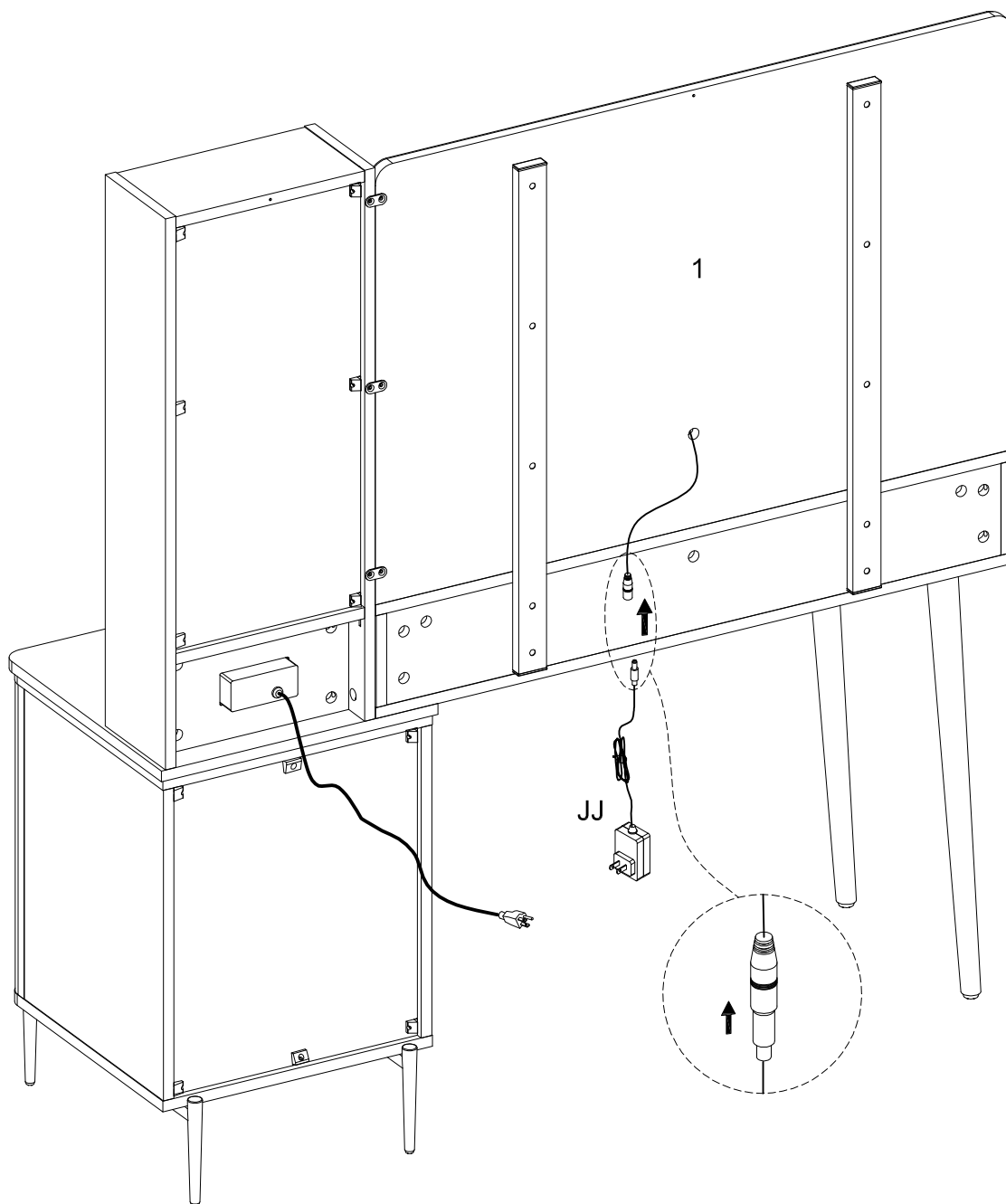

Step 37

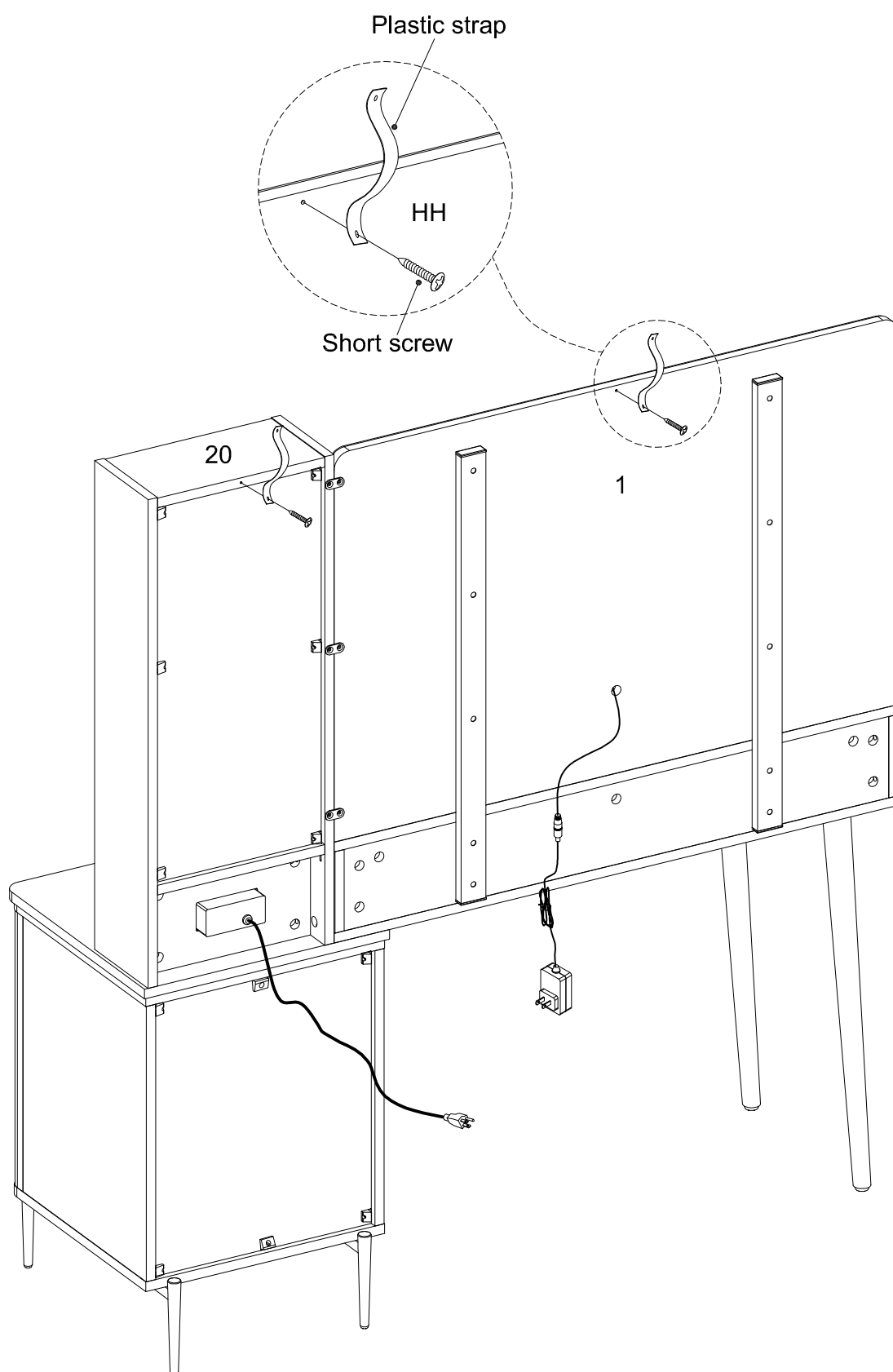

Step 38

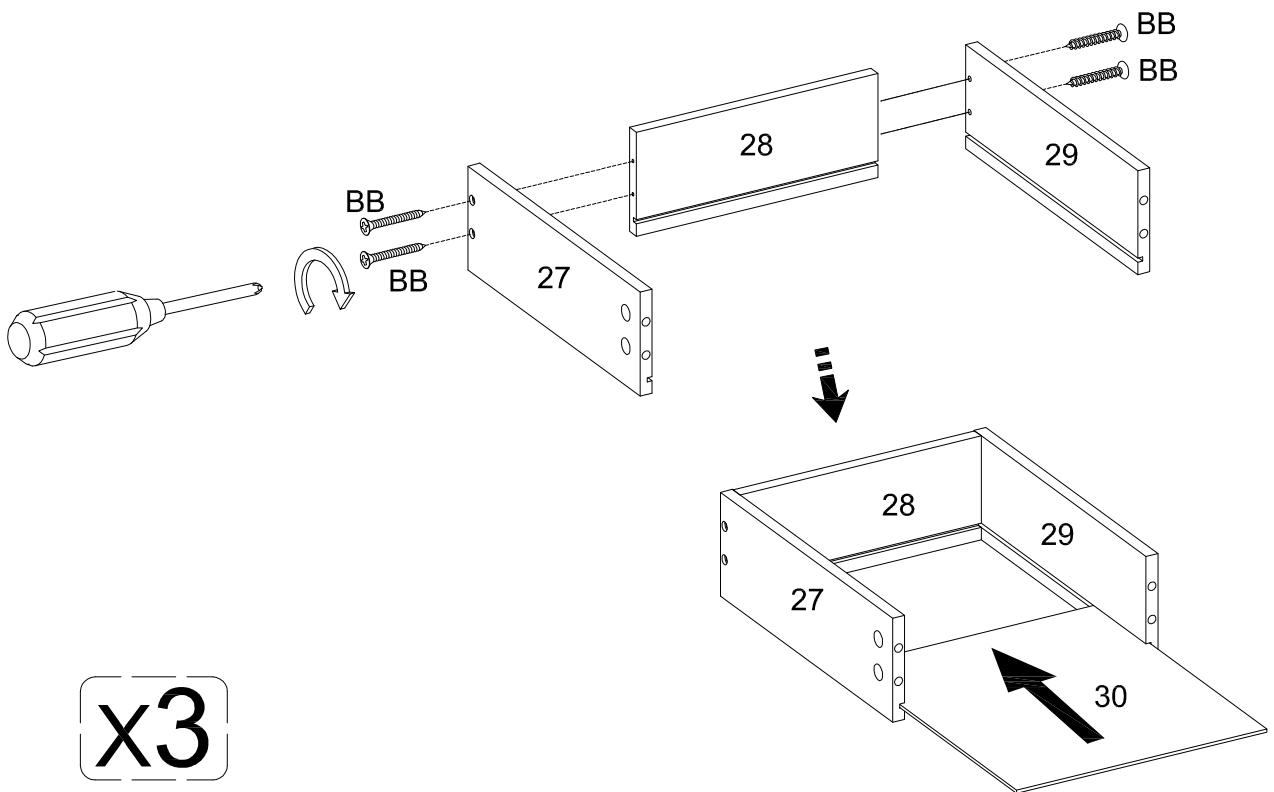

Step 39

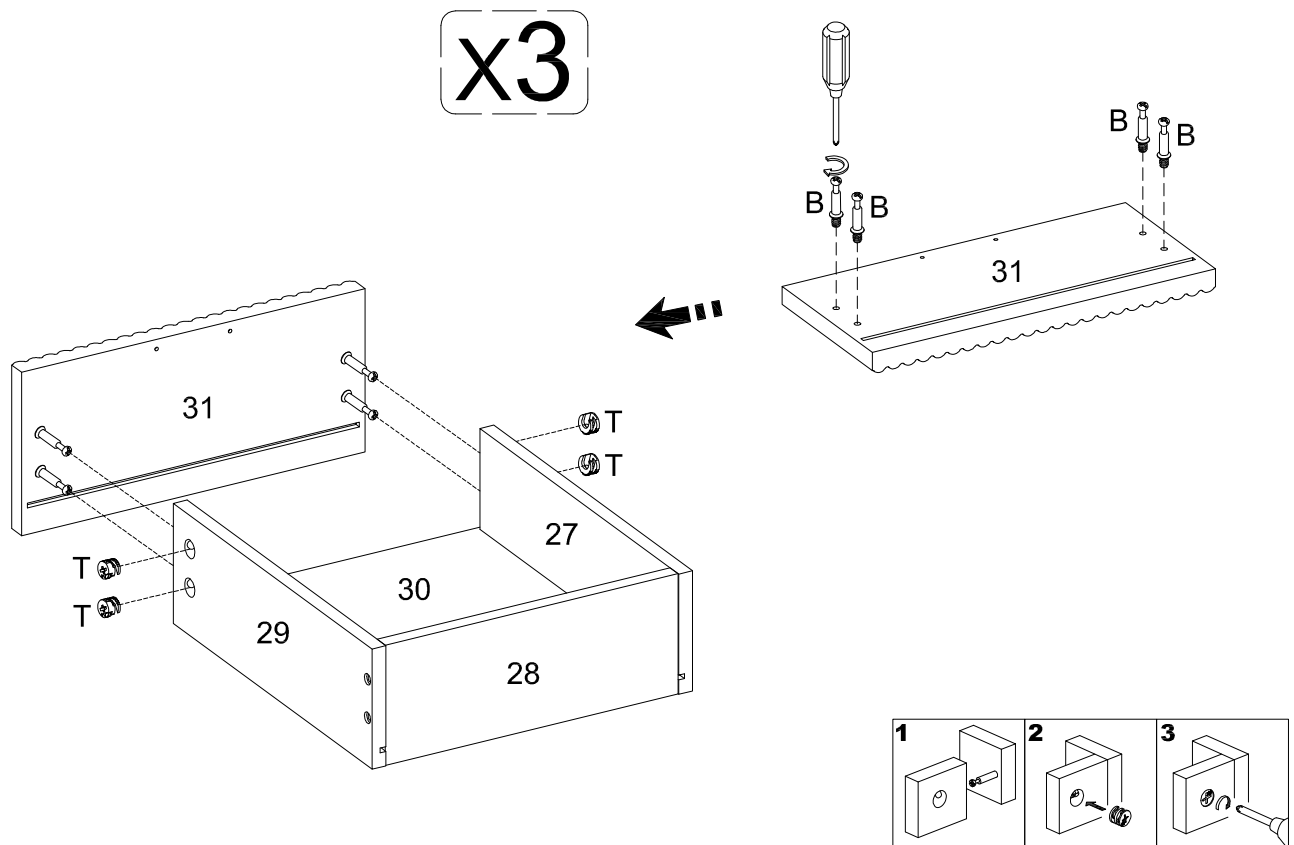

Step 40

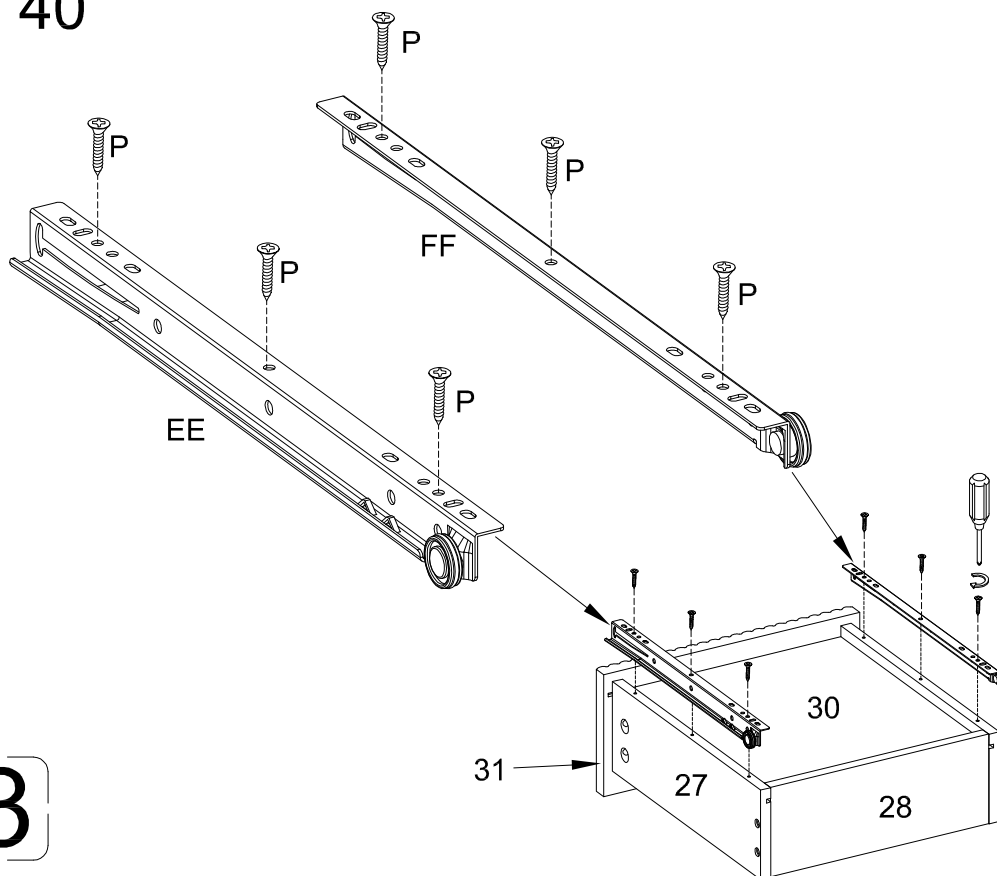

x3

Step 41

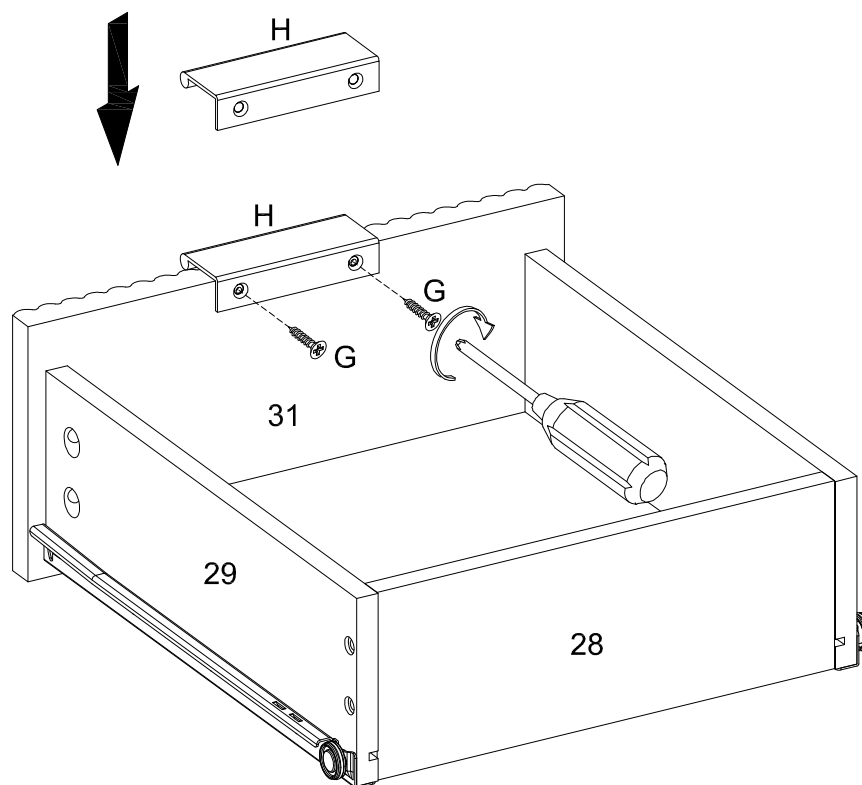

x3

Step 42

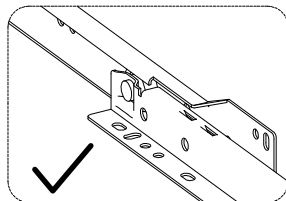
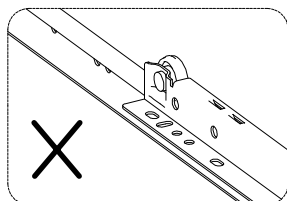
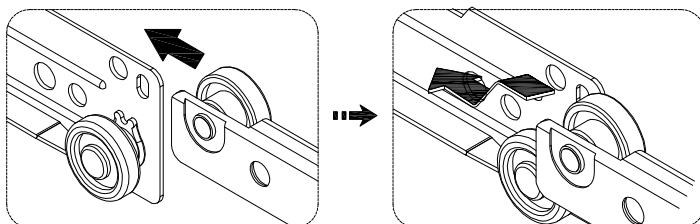
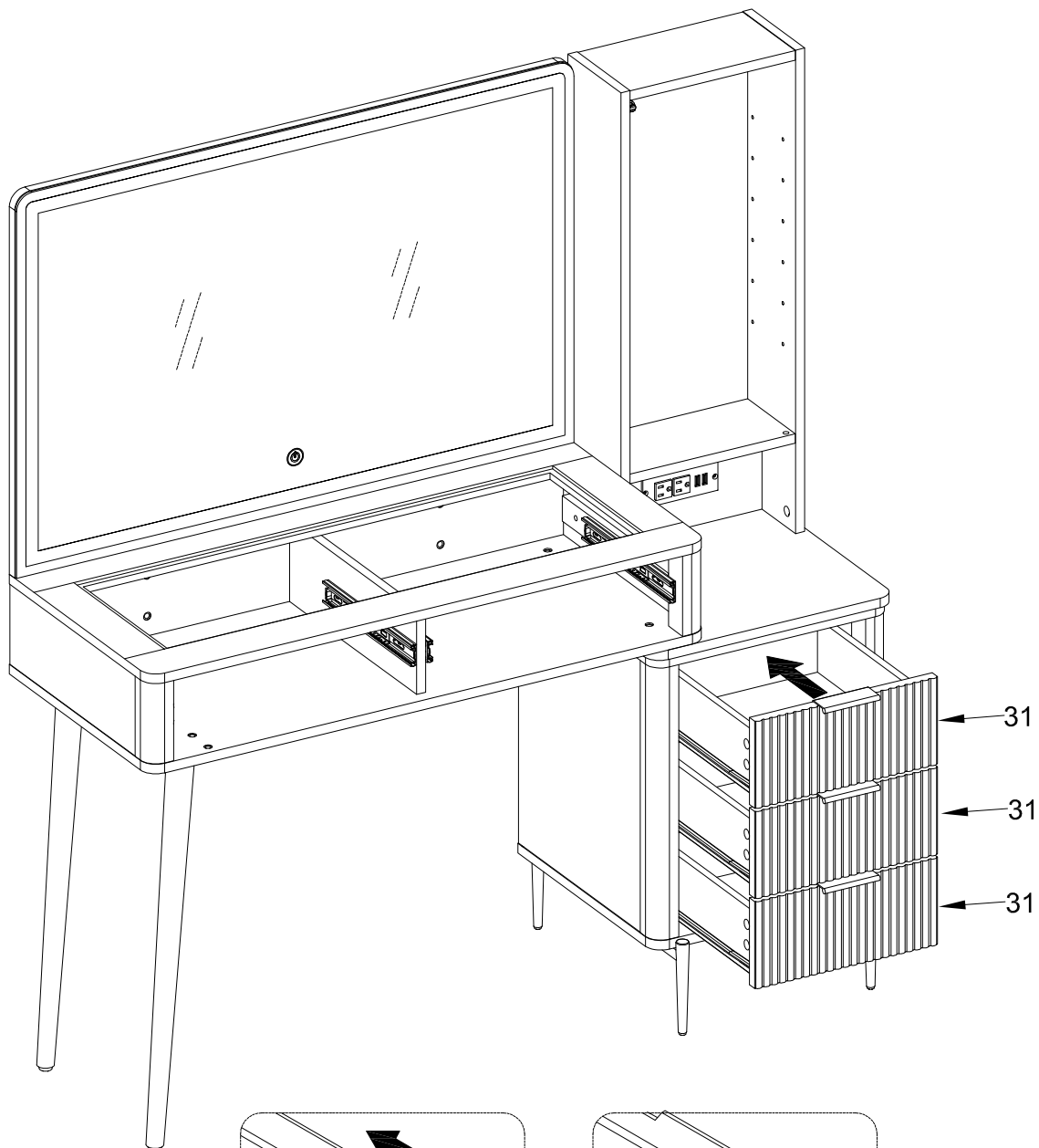

Step 43

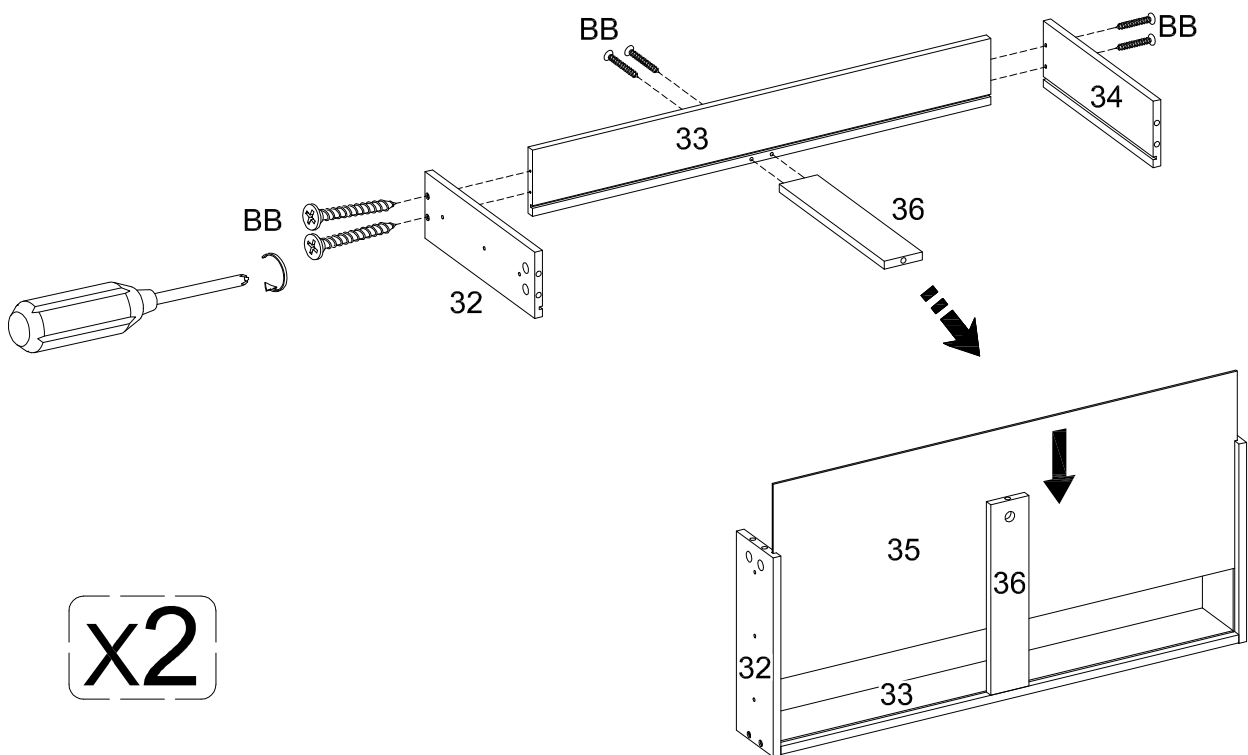

Step 44

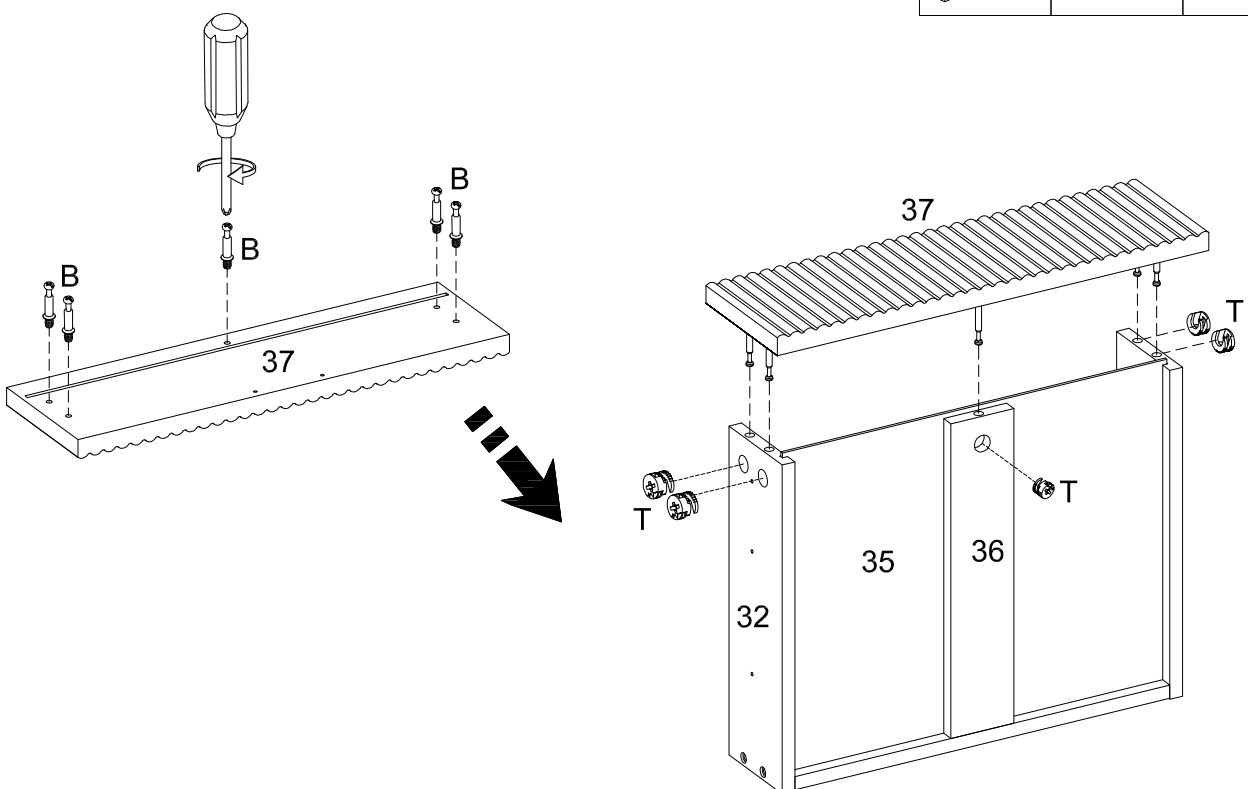

Step 45

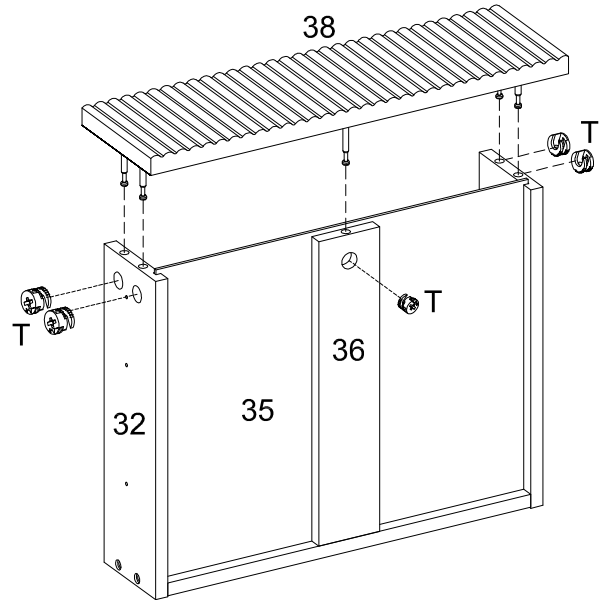
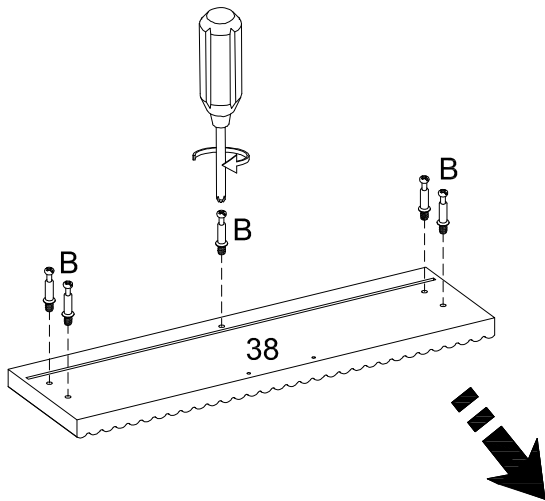
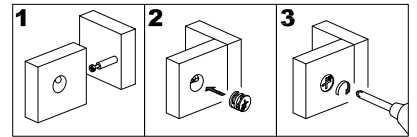

Step 46

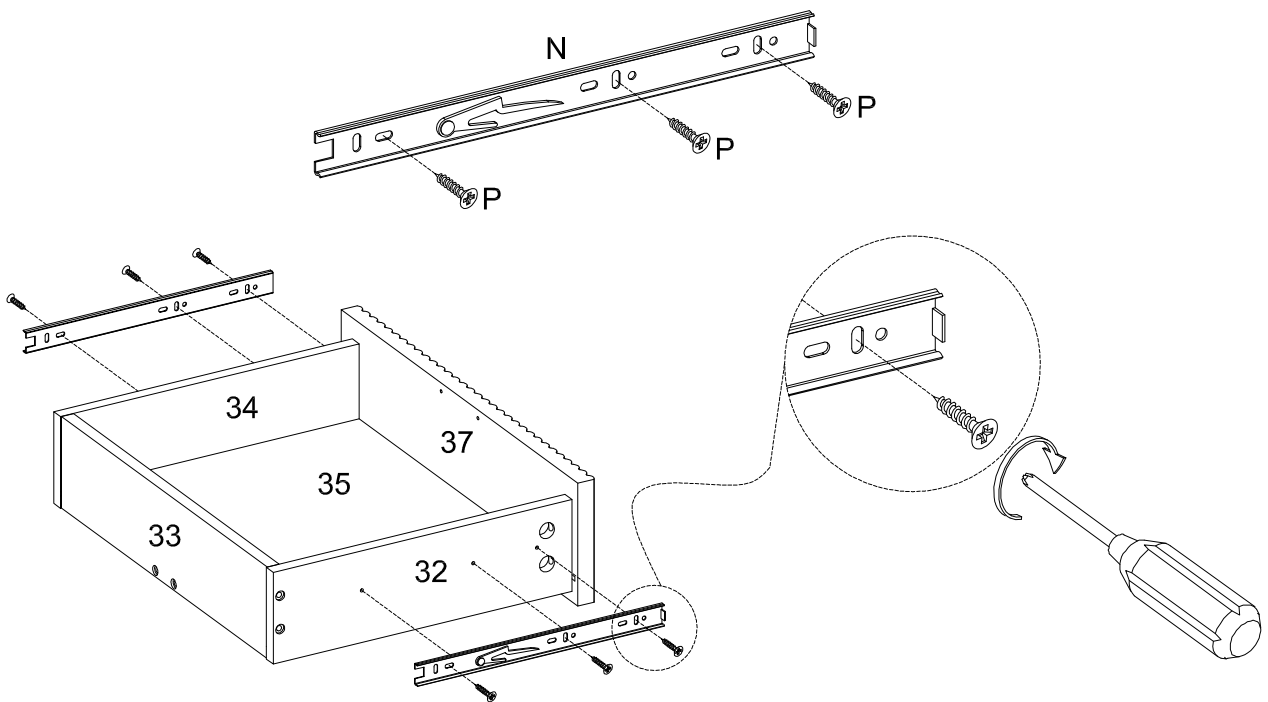

Step 47

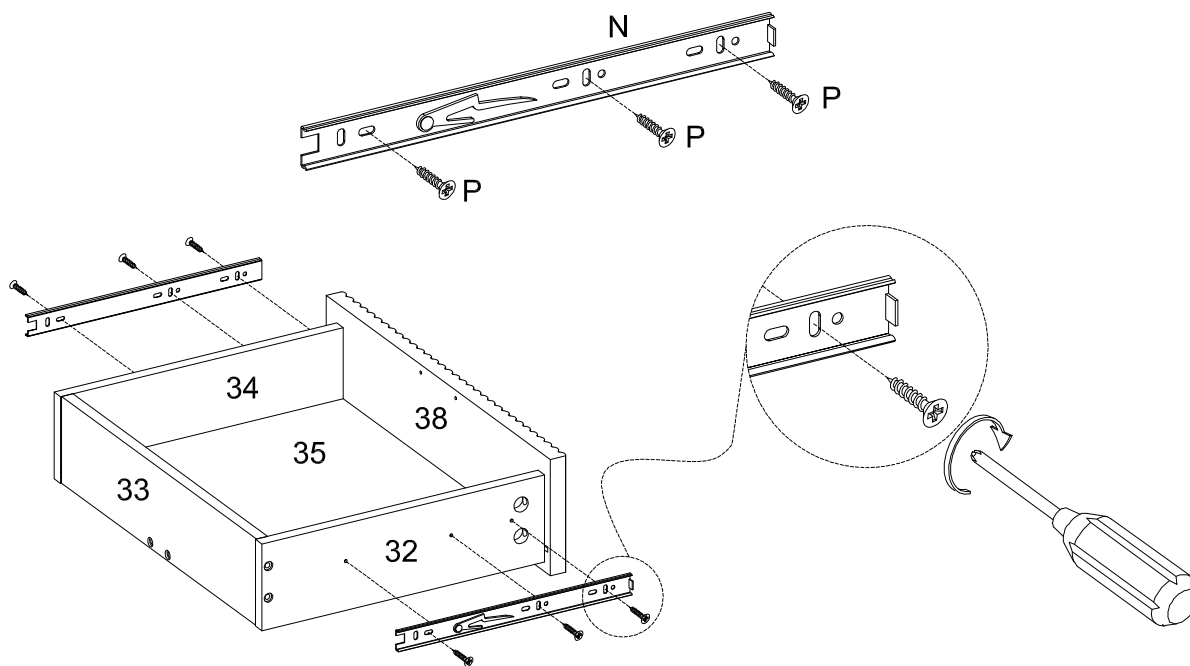

Step 48

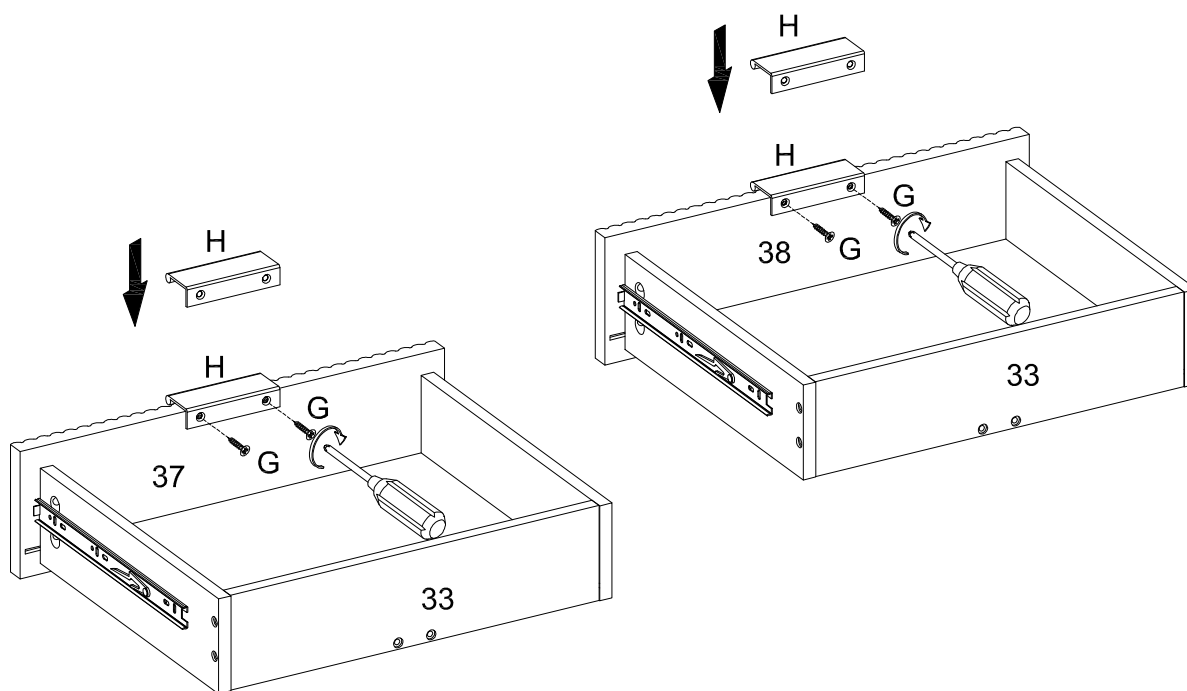

Step 49

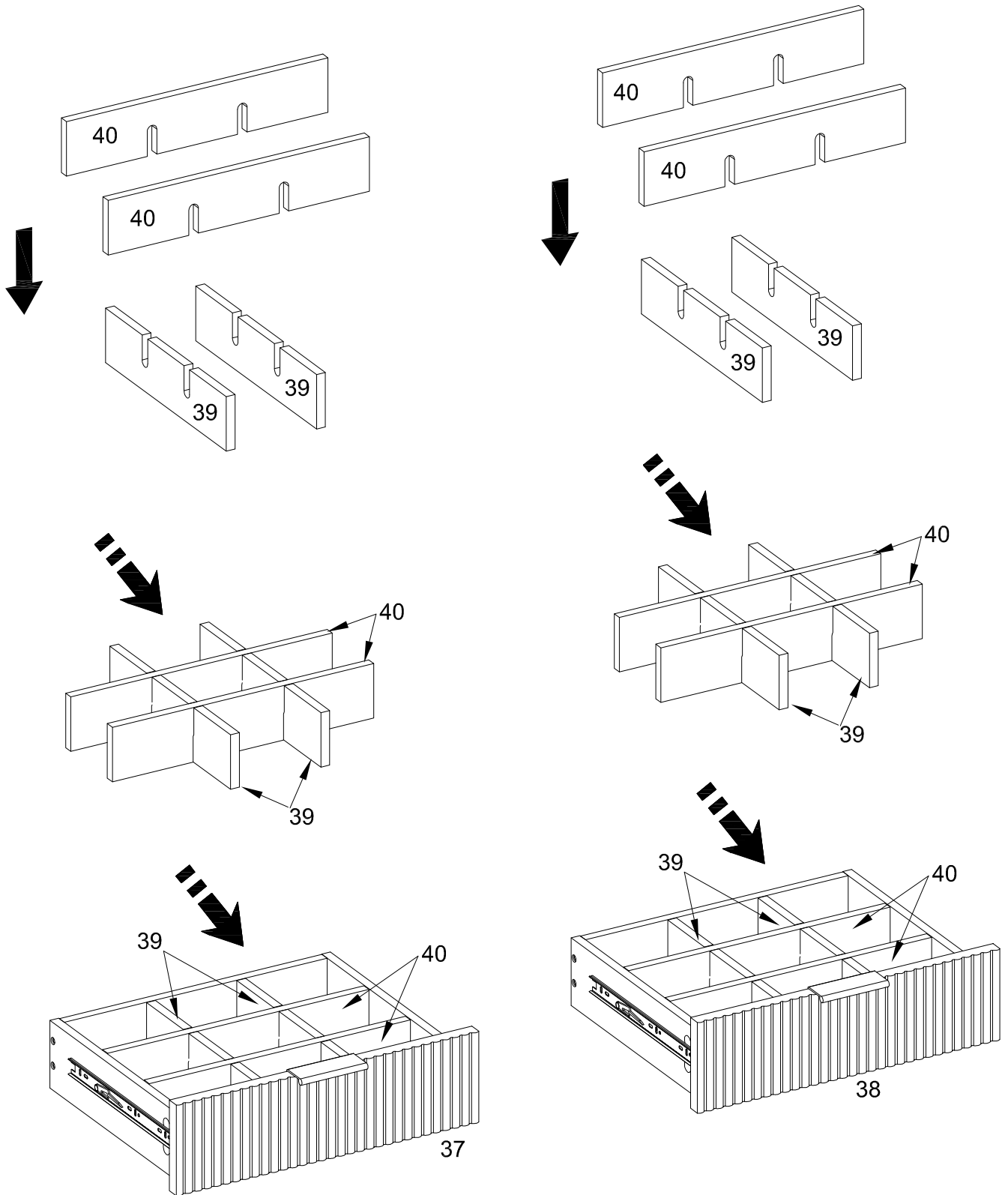

Step 50

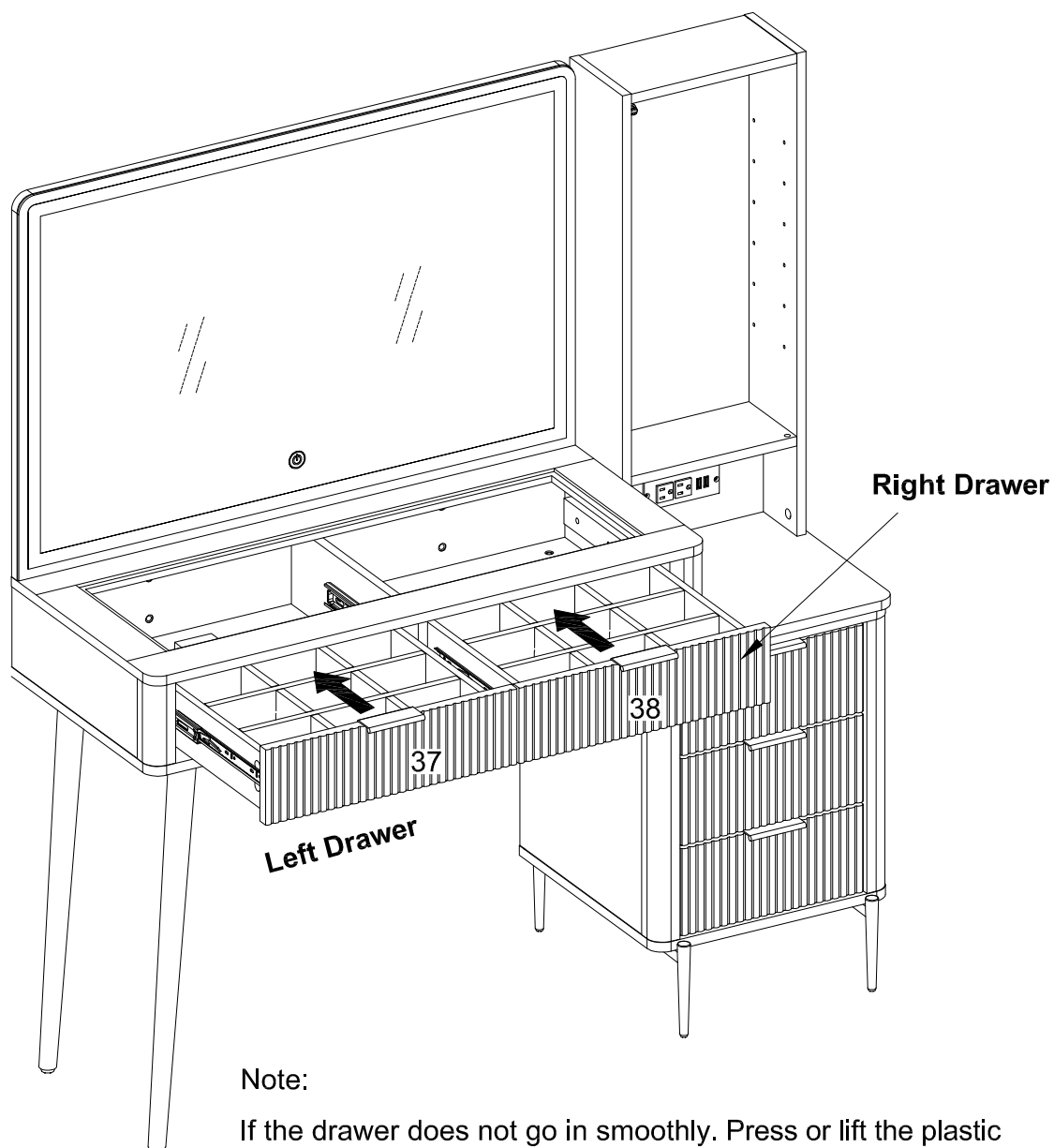

Note:

If the drawer does not go in smoothly. Press or lift the plastic release lever. Pull out the slider bracket from the slider arm. Loosen the screws(p) on slider brackets, You can adjust up or down by a few mm. Then tighten back up. Finally re-assembled the drawer until they were going in smoothly well.

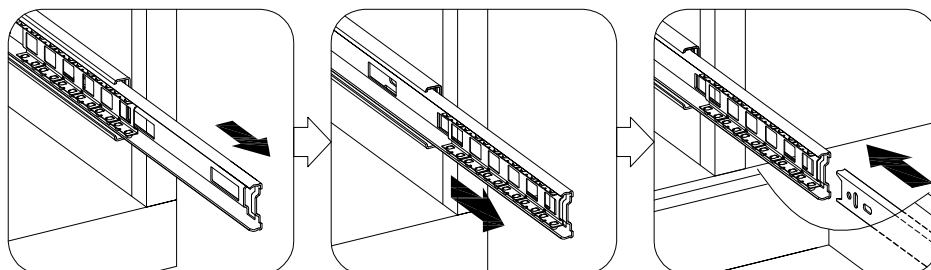

Step 51

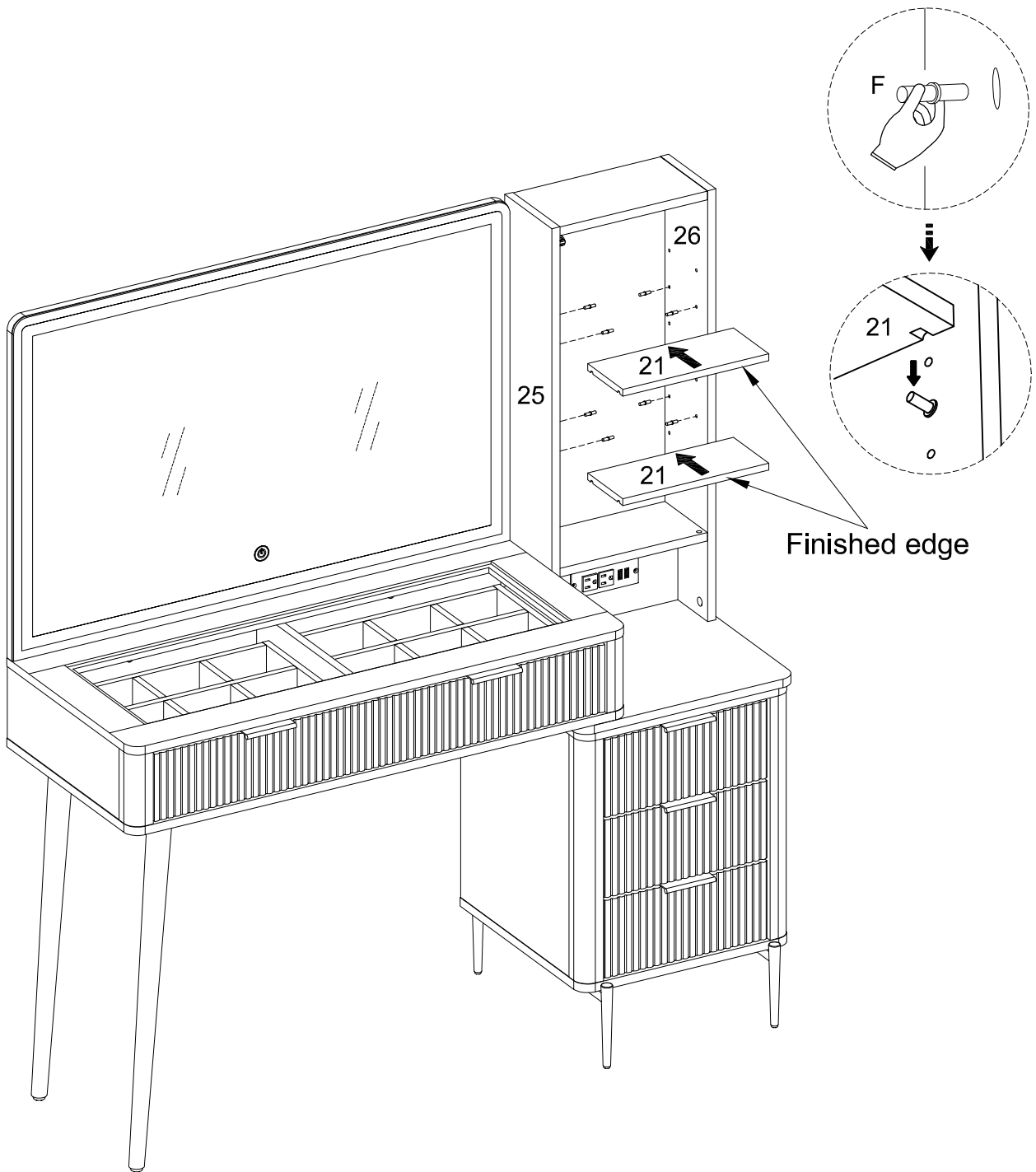

Step 52

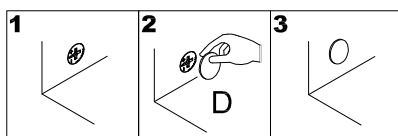
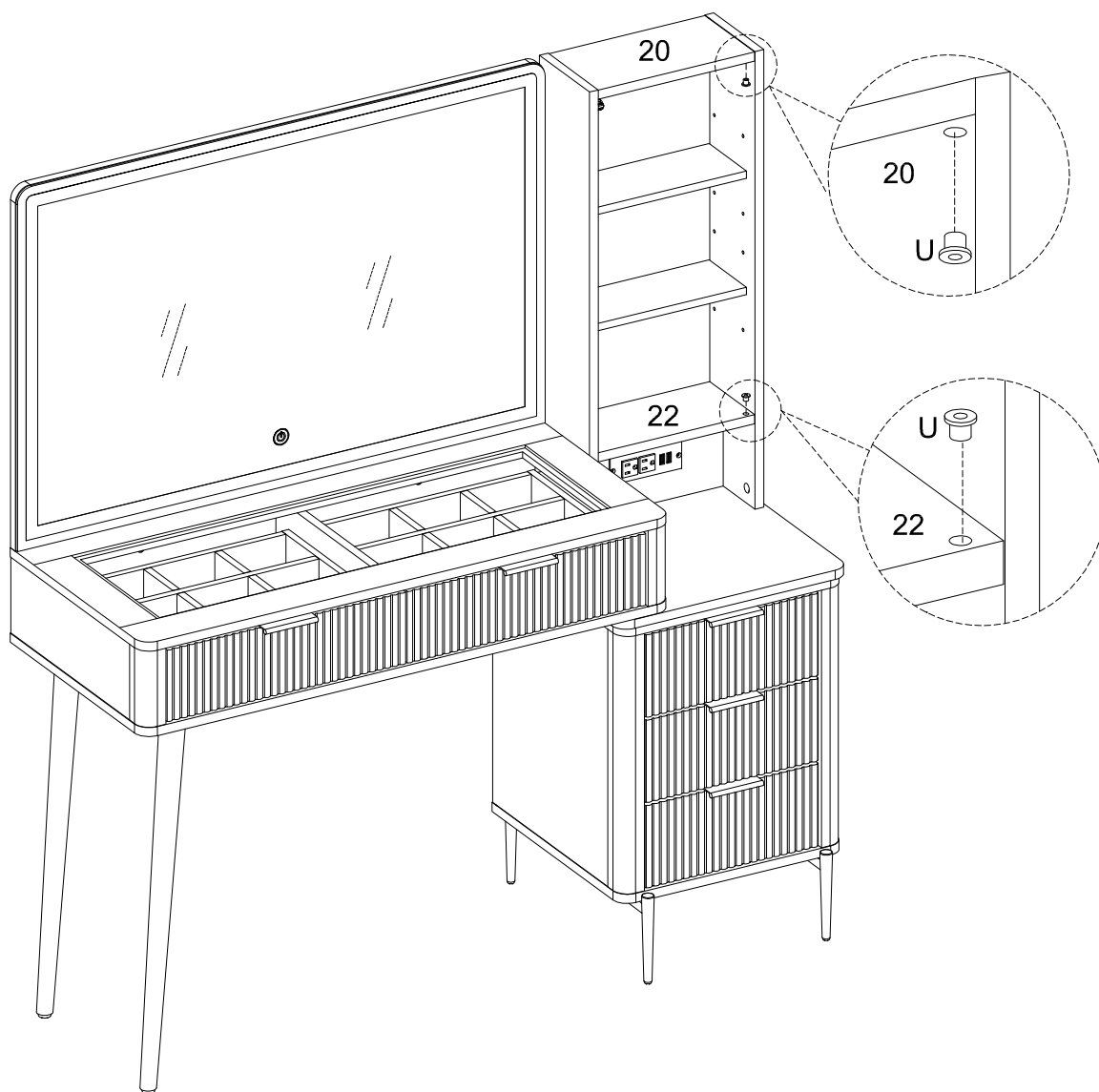

Step 53

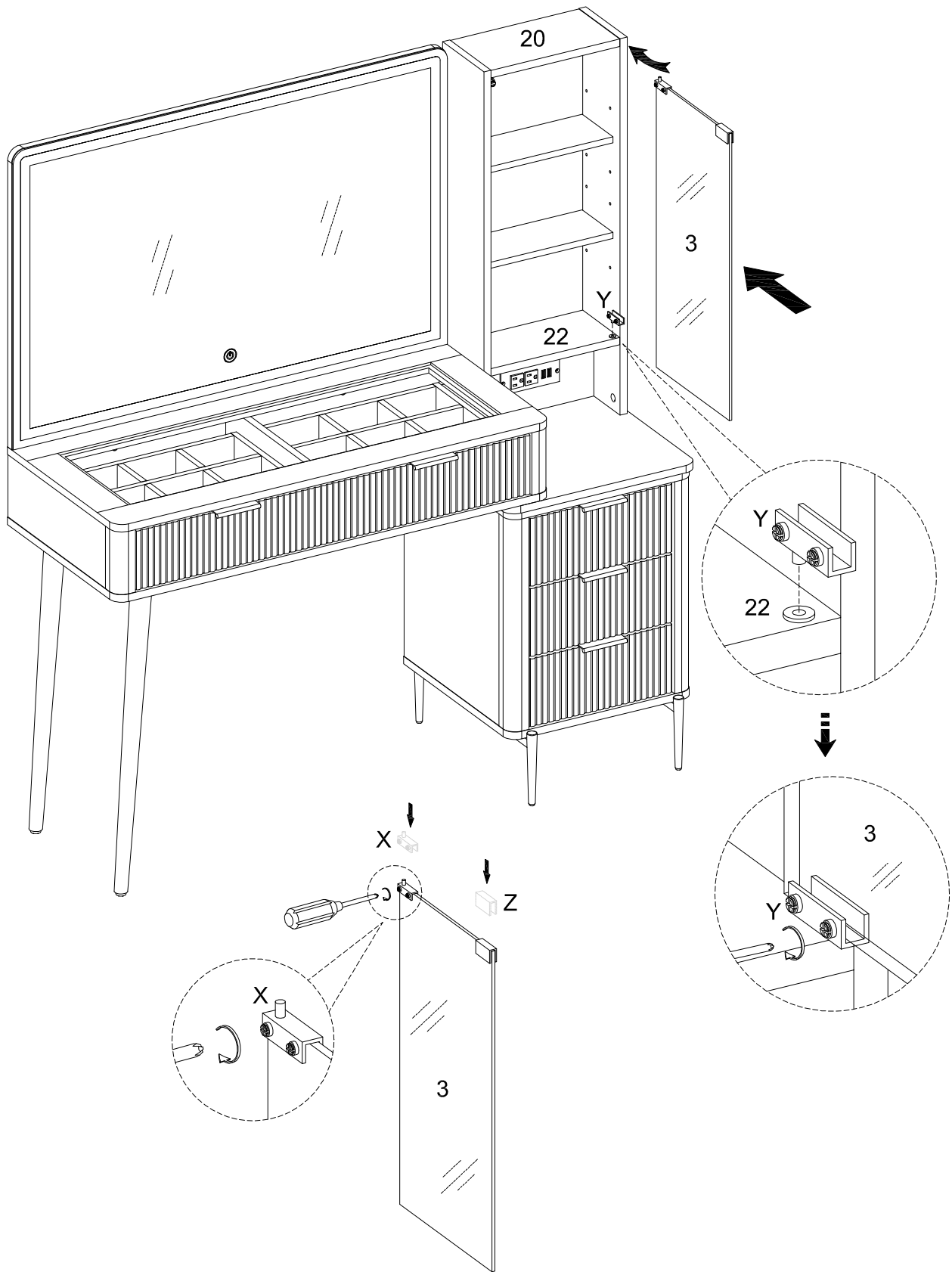

Step 54

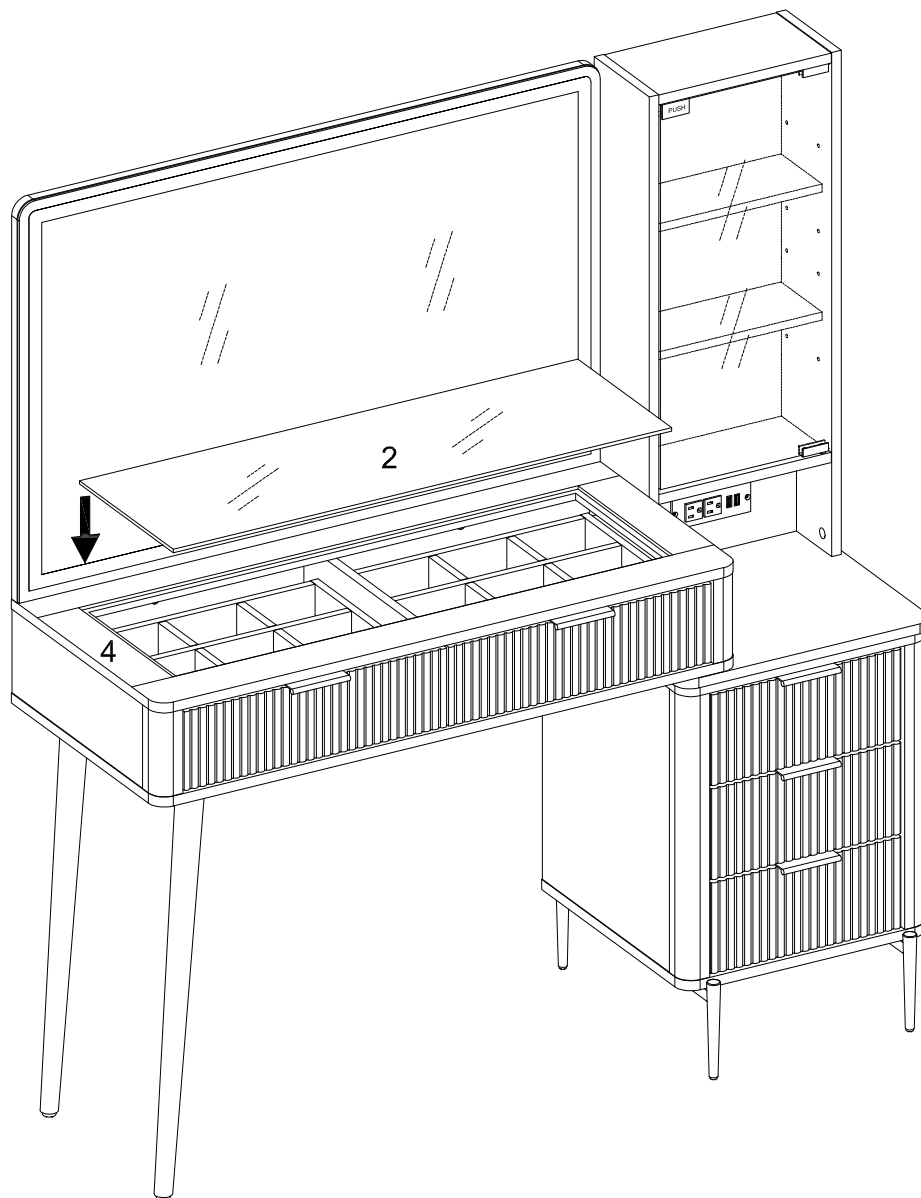

Step 55

Serious or fatal injuries can occur from furniture tipping over. To prevent the furniture from tipping over we recommend that it is permanently fixed to the wall. Wall anchor and hardware are included with this product. Please make sure hardware is suitable for your walls before installing, as different wall materials may require different types of anchors.

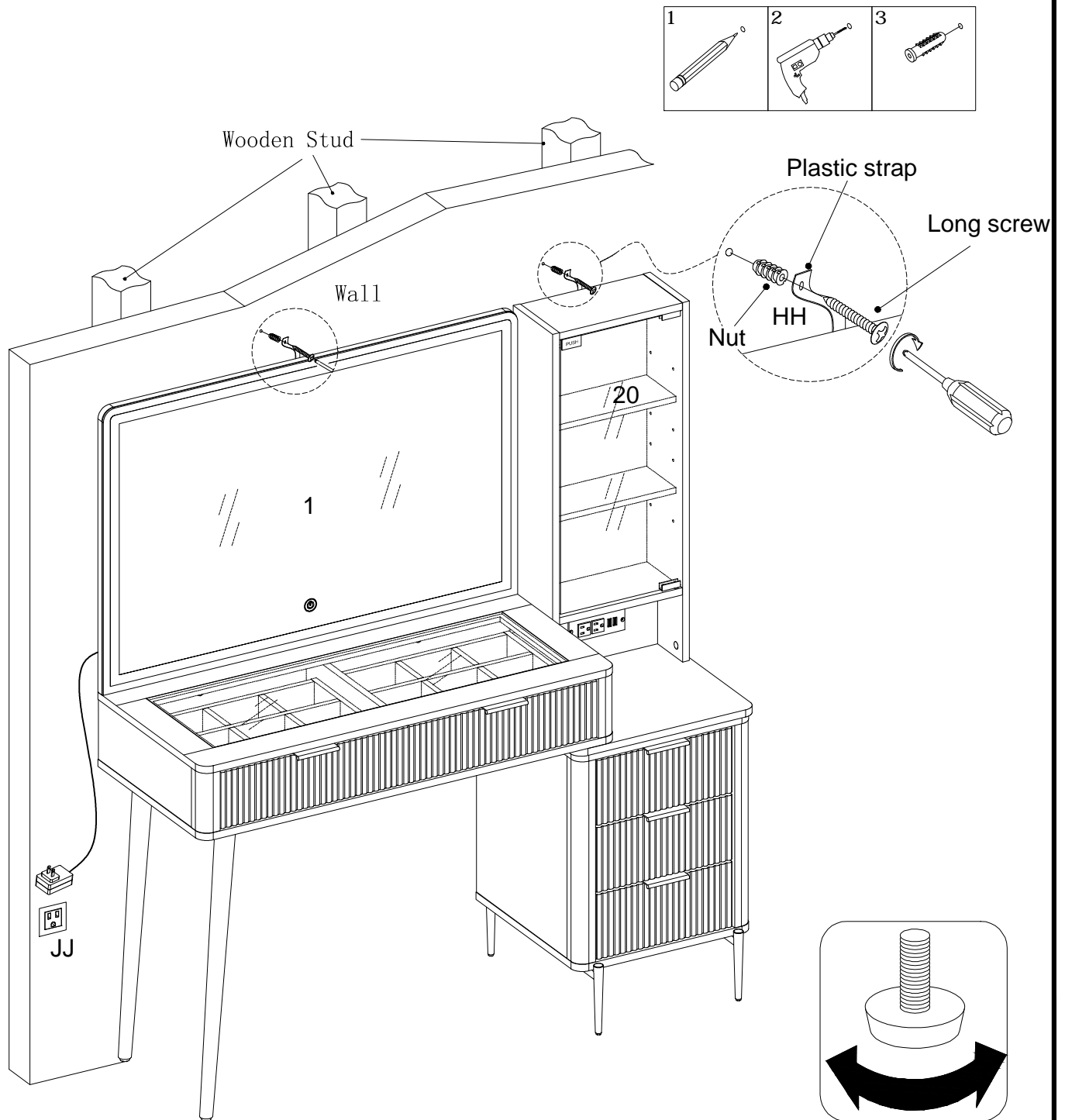

Position the assembled unit at the desired location, if necessary adjust the floor leveler at the bottom of the leg to level the unit.

Step 56

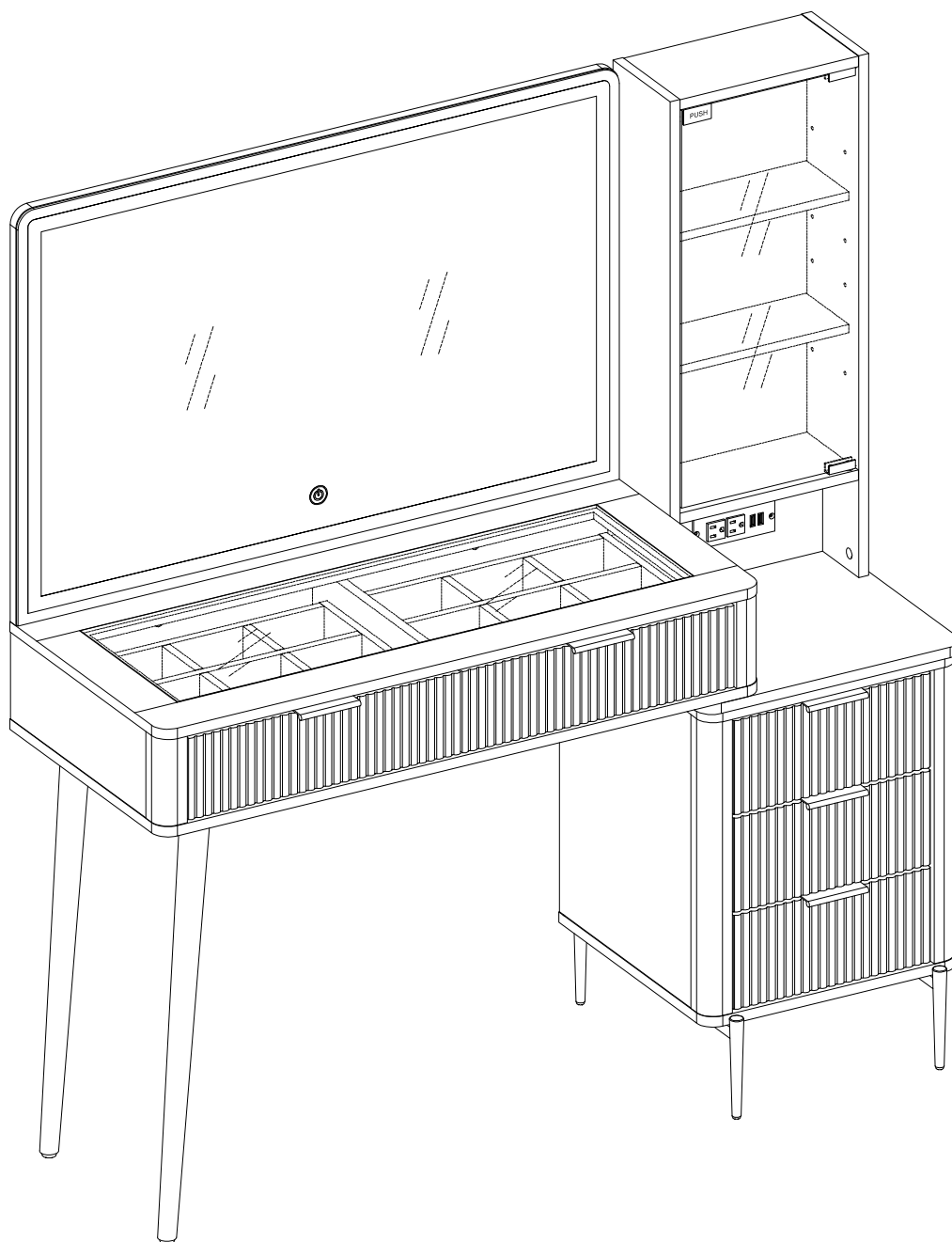

Final Assembly