

JYDBD003F/Q

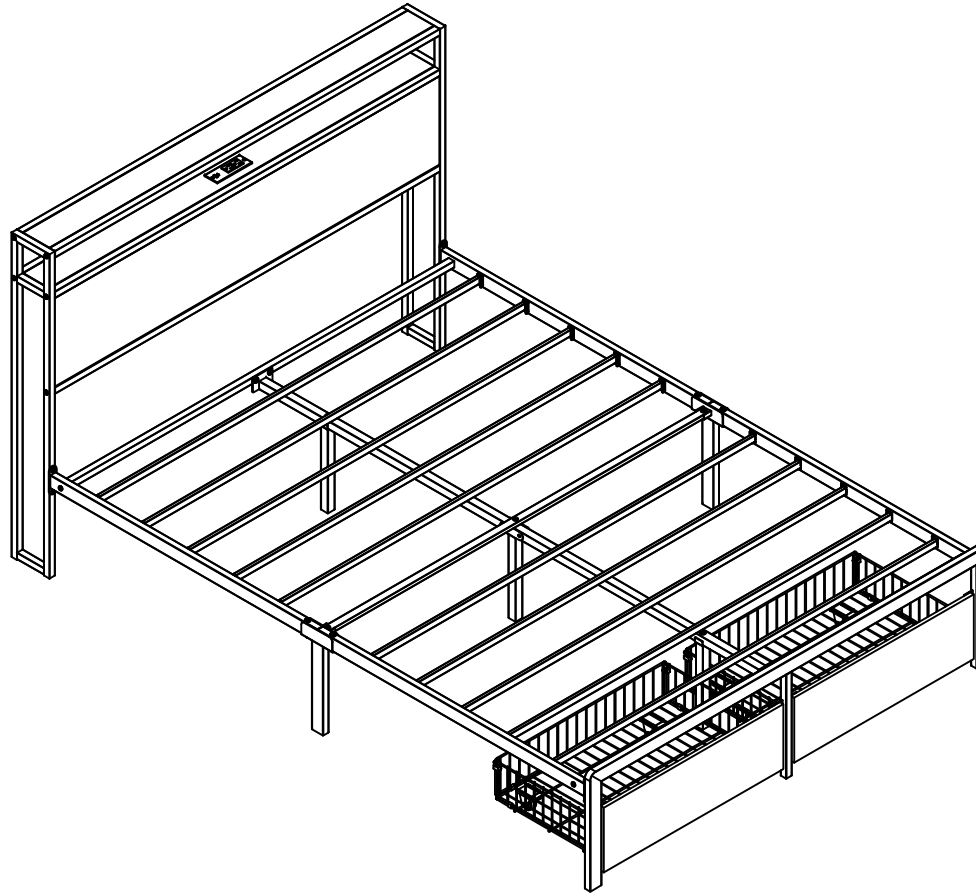

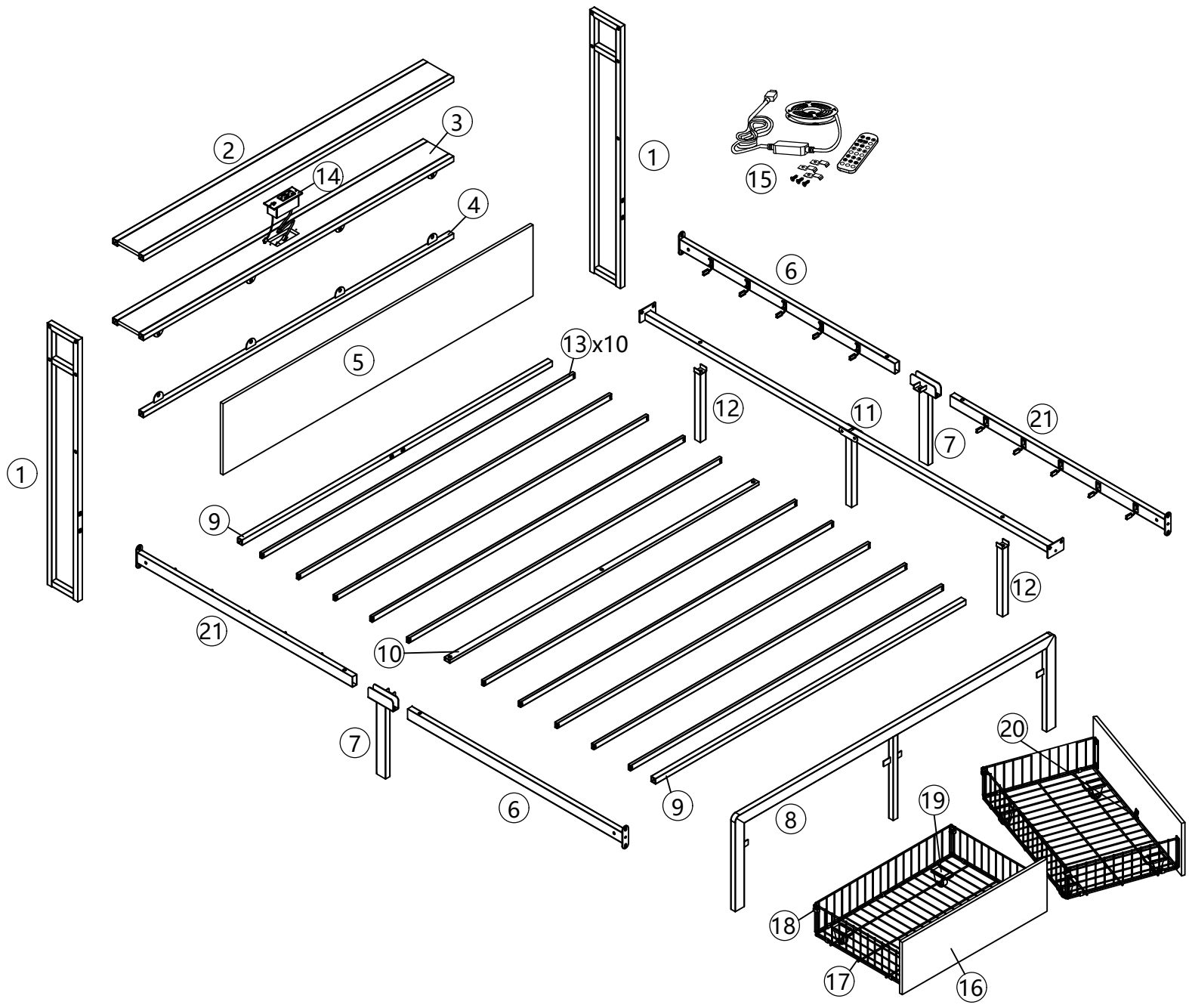









Attention: Please don't tighten the screws completely and go back later for a final tightening of all the screws after pieces are aligned with each other. If the screws are tightened initially, subsequent hole positions may be misaligned.







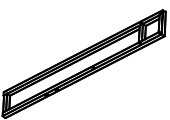
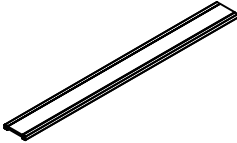
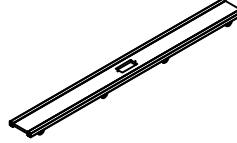
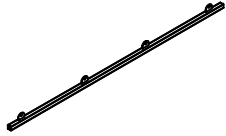
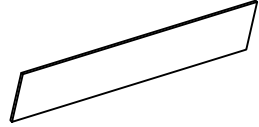
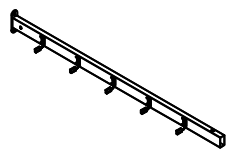
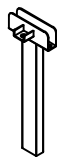
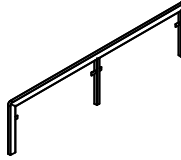
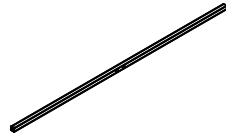
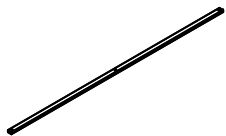
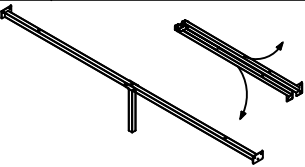

Hardware arts

⚠ Tips: The number after “+” represents the spare hardware.

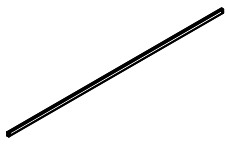
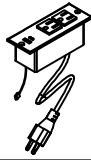
A		M4X12	2 _{+1pc}	C		M6x12mm	10 _{+1pc}	E		M6x50mm	1 _{+1pc}	G		M8x35mm	2 _{+1pc}	I		4#	1
B		M6x10mm	8 _{+1pc}	D		M6x40mm	14 _{+1pc}	F		M8x20mm	14 _{+1pc}	H		M8x50mm	4 _{+1pc}	J		5#	1

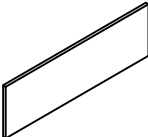
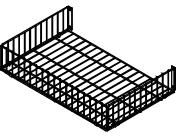
Part list

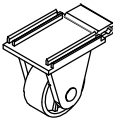
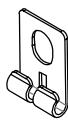
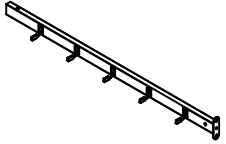

	①	2 pcs		②	1pc		③	1pc		④	1pc		⑤	1 pc
	⑥	2 pcs		⑦	2 pcs		⑧	1 pc		⑨	2 pcs		⑩	1 pc
	⑪	1 pc		⑫	2 pcs		⑬	10 pcs		⑭	1 pc		⑮	1 pc
	⑯	2 pcs		⑰	2 pcs		⑱	4 pcs		⑲	8 pcs		⑳	2 pcs
	㉑	2 pcs												

Step:1

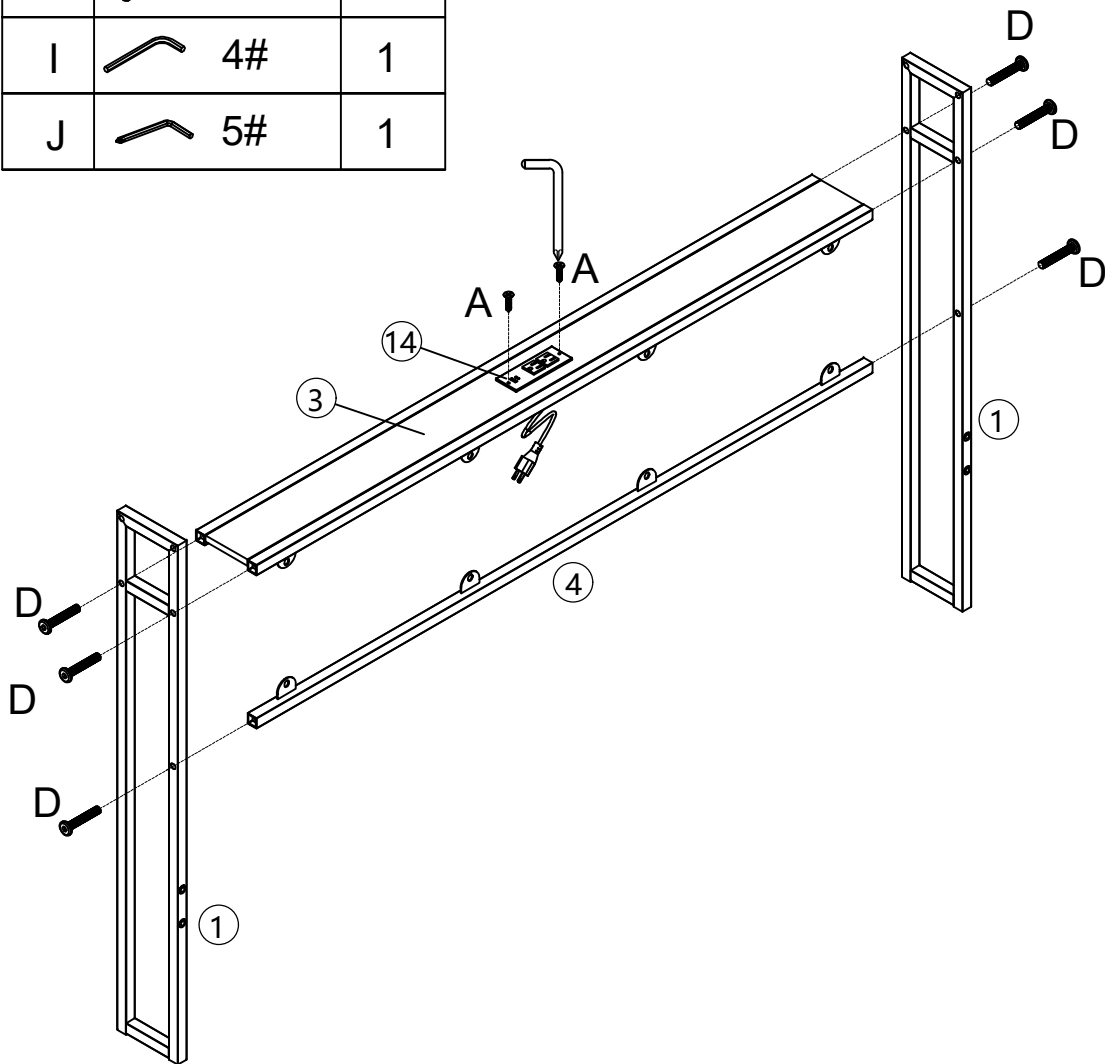
A		M4x12mm	2
D		M6x40mm	6
I		4#	1
J		5#	1



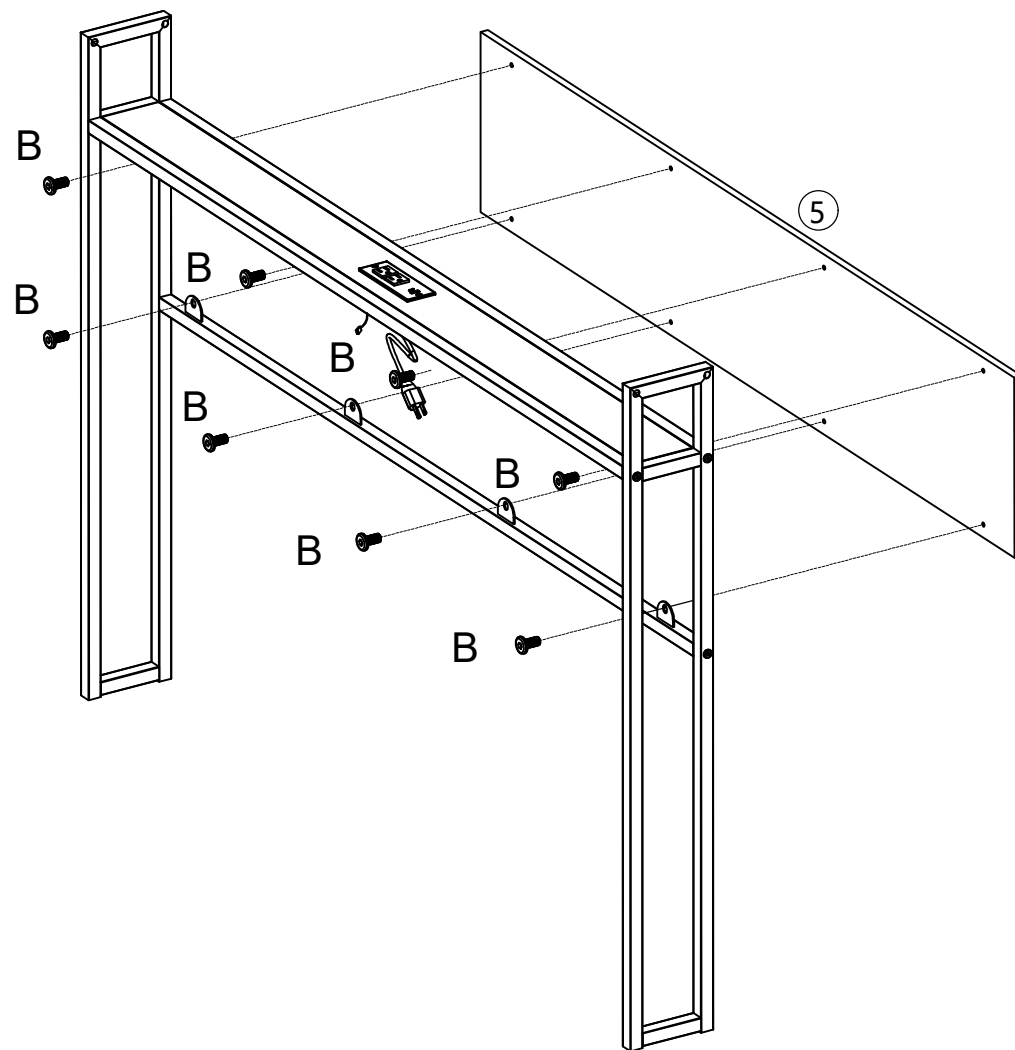

Step:2

B		M6x10mm	8
I		4#	1





Please don't tighten the screws completely and go back later for a final tightening of all the screws after pieces are aligned with each other.

Step:3

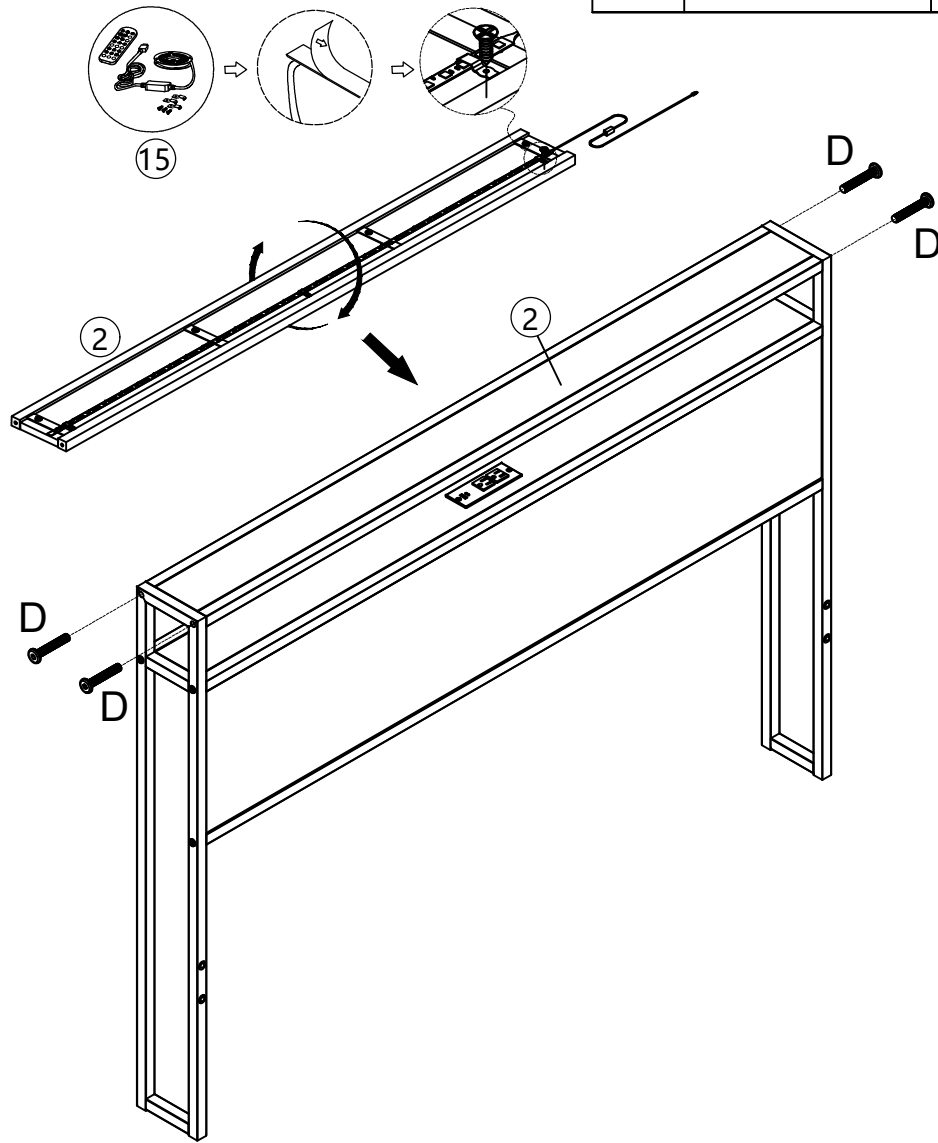
D	 M6x40mm	4
I	 4#	1



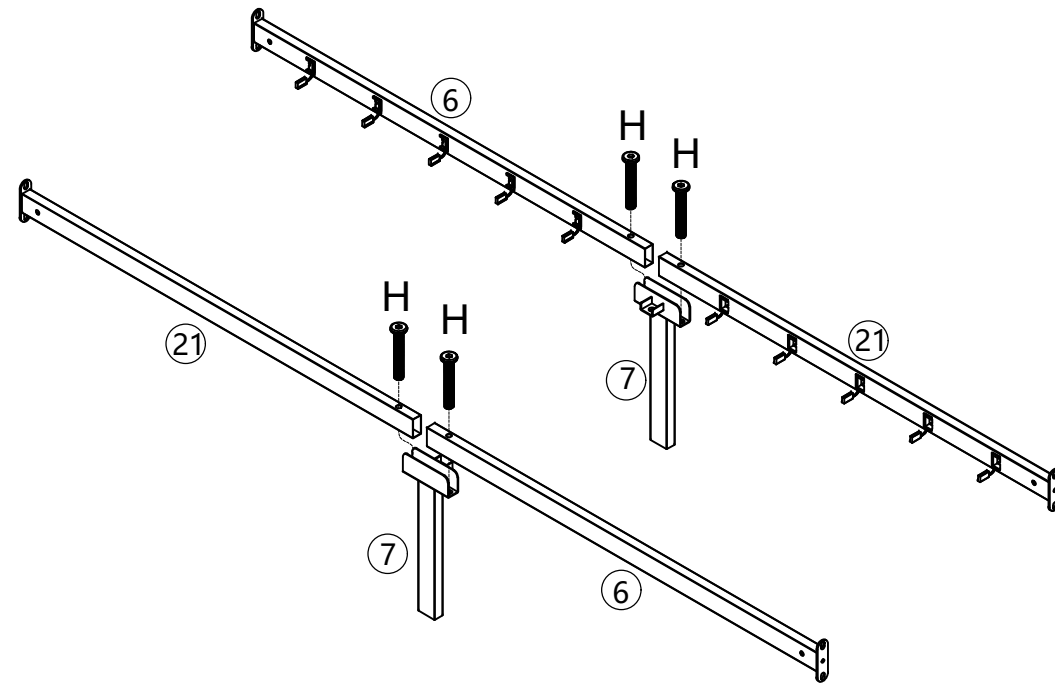

Step:4

H	 M8x50mm	4
J	 5#	1





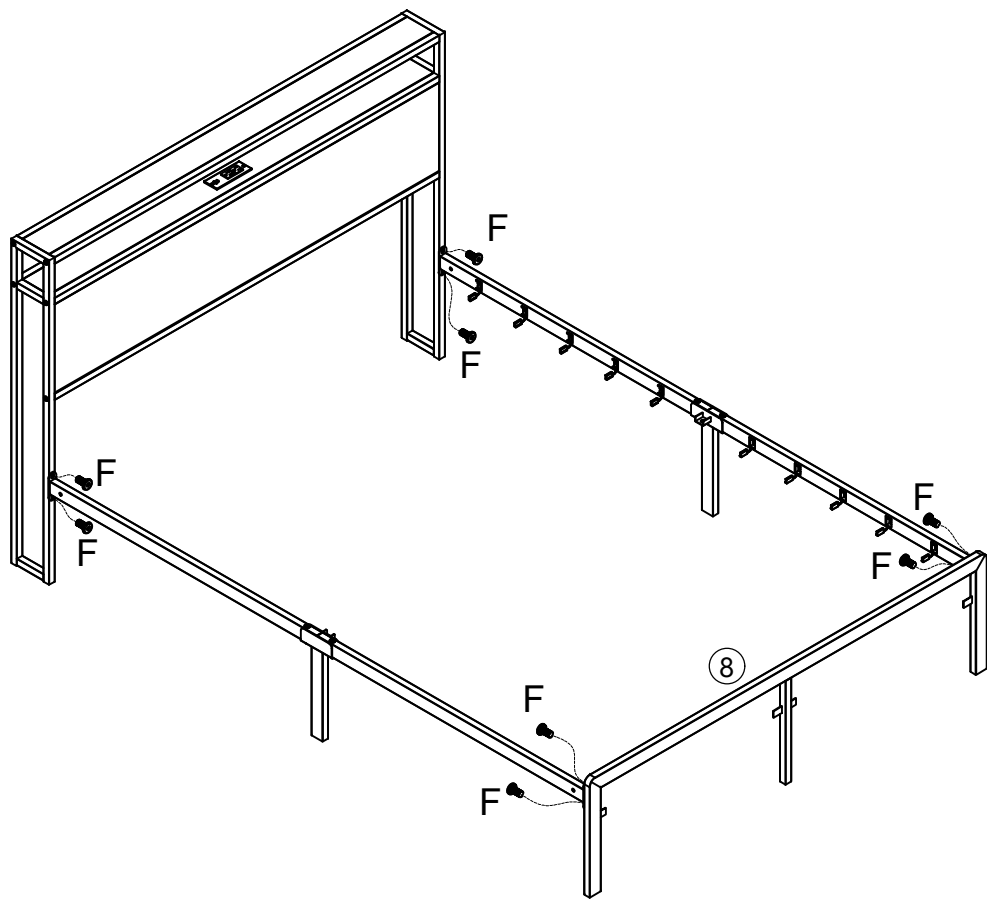

Please don't tighten the screws completely and go back later for a final tightening of all the screws after pieces are aligned with each other.

Step:5

F	 M8x20mm	8
J	 5#	1





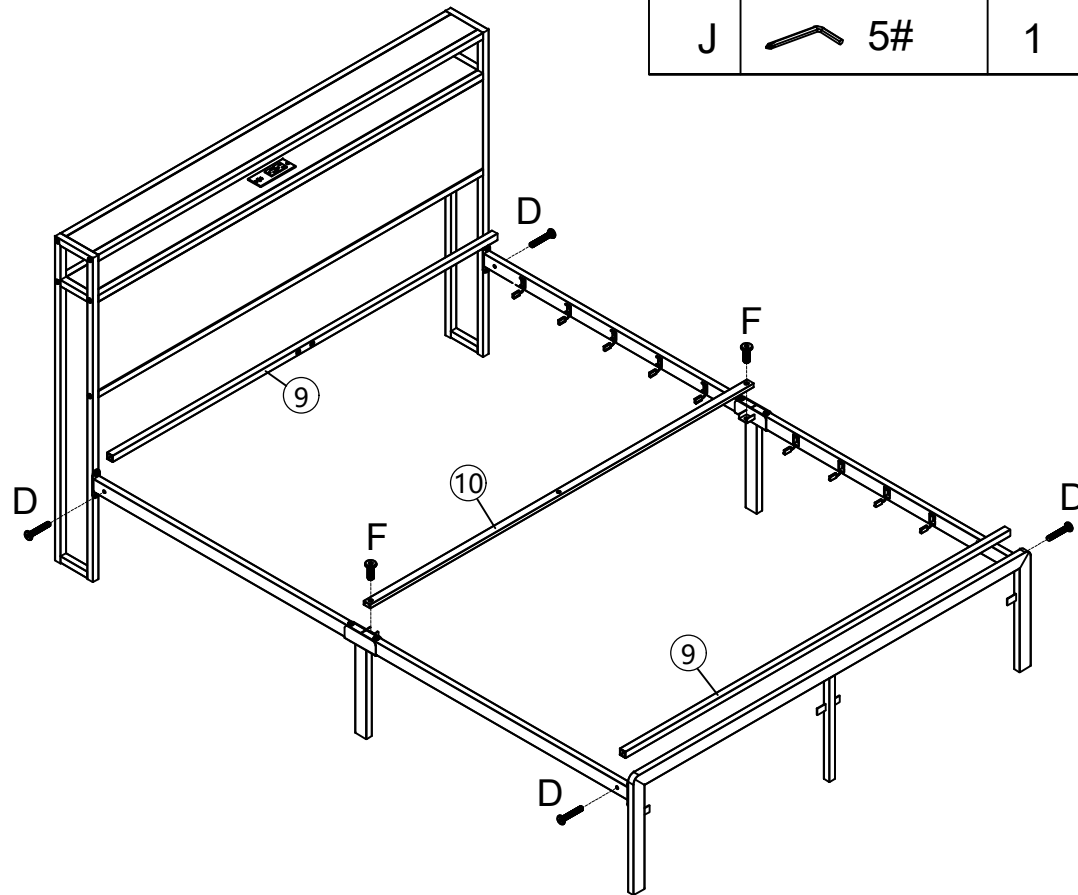

Step:6

D	 M6x40mm	4
F	 M8x20mm	2
I	 4#	1
J	 5#	1



Please don't tighten the screws completely and go back later for a final tightening of all the screws after pieces are aligned with each other.

Step:7

E		M6x50mm	1
F		M8x20mm	4
G		M8x35mm	2
I		4#	1
J		5#	1

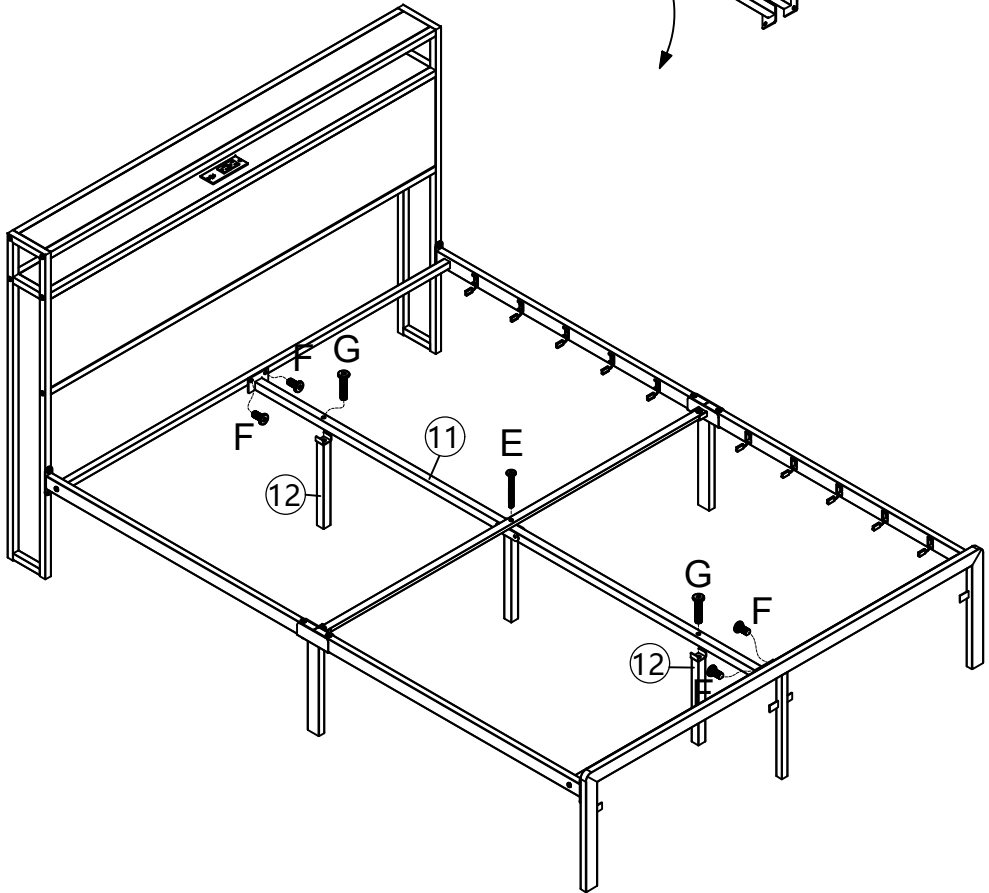
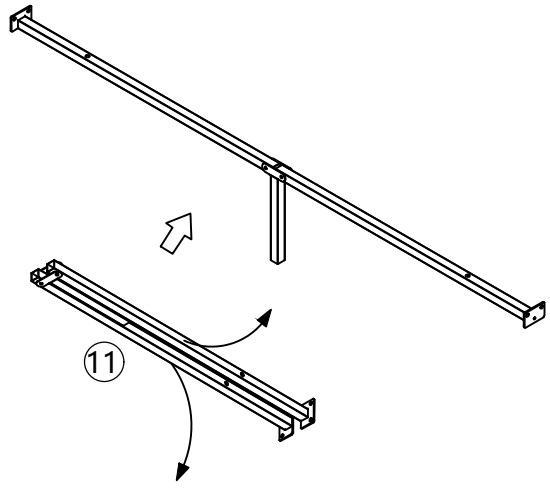

Step:8

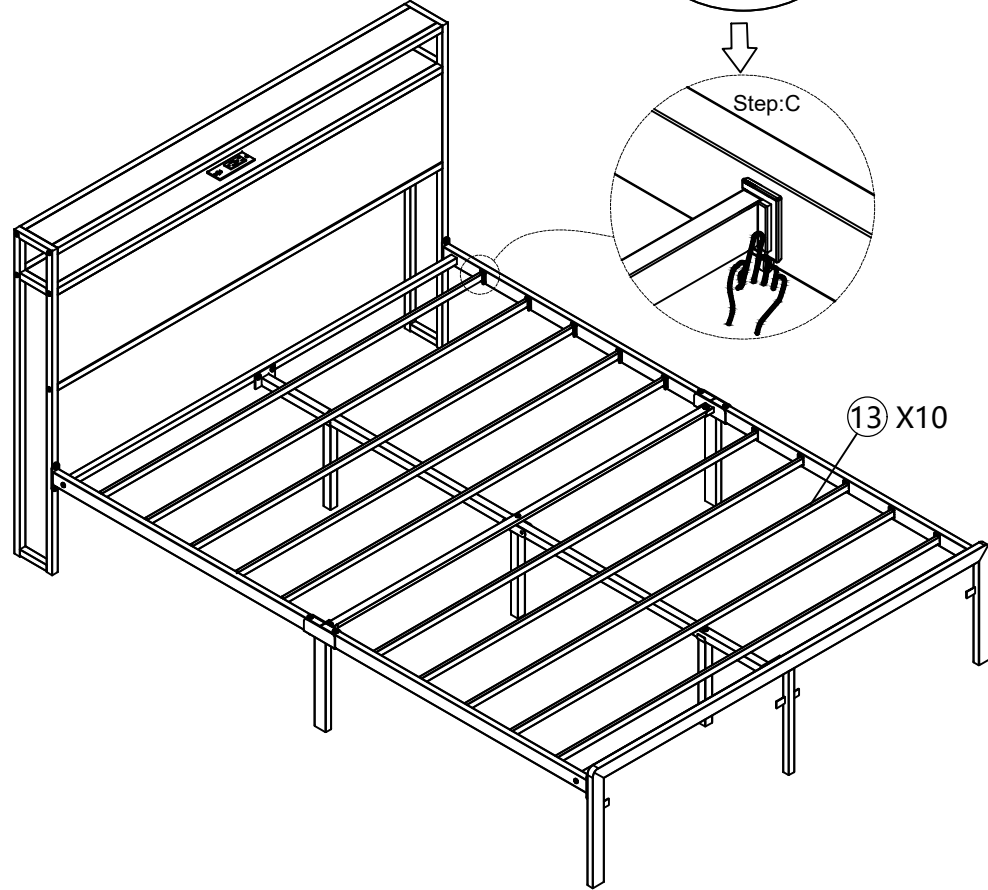
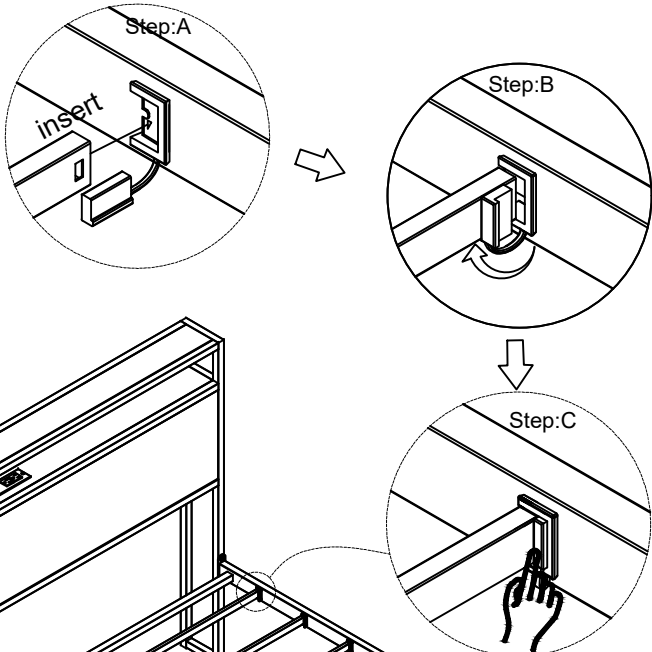

Step:9

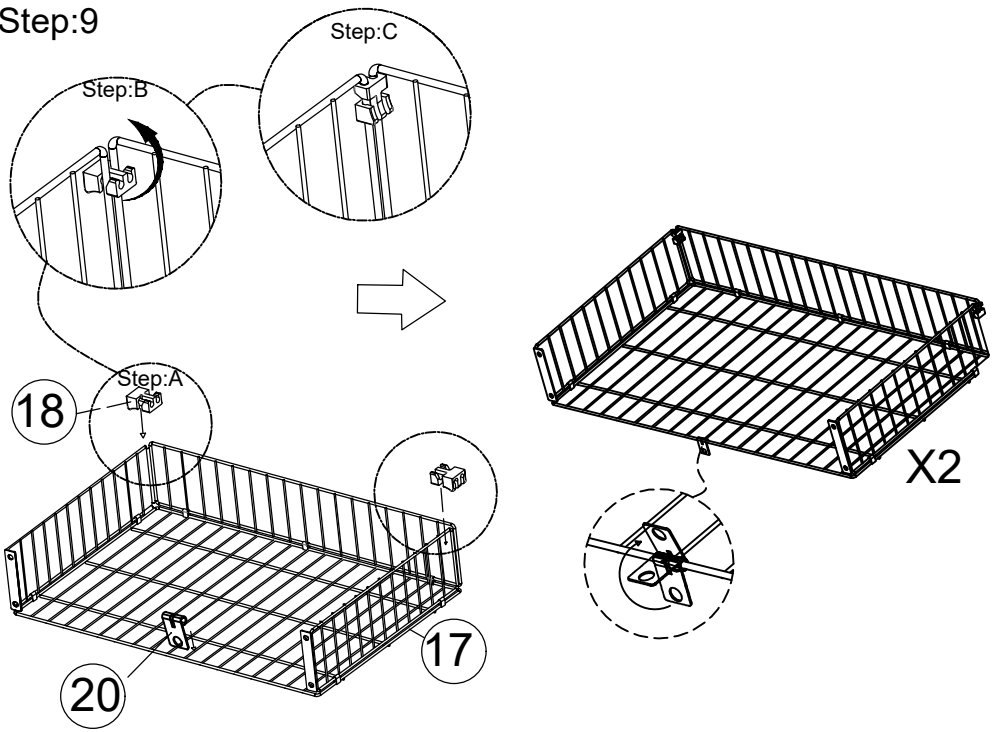

Step:11

C		M6x12mm	10
I		4#	1

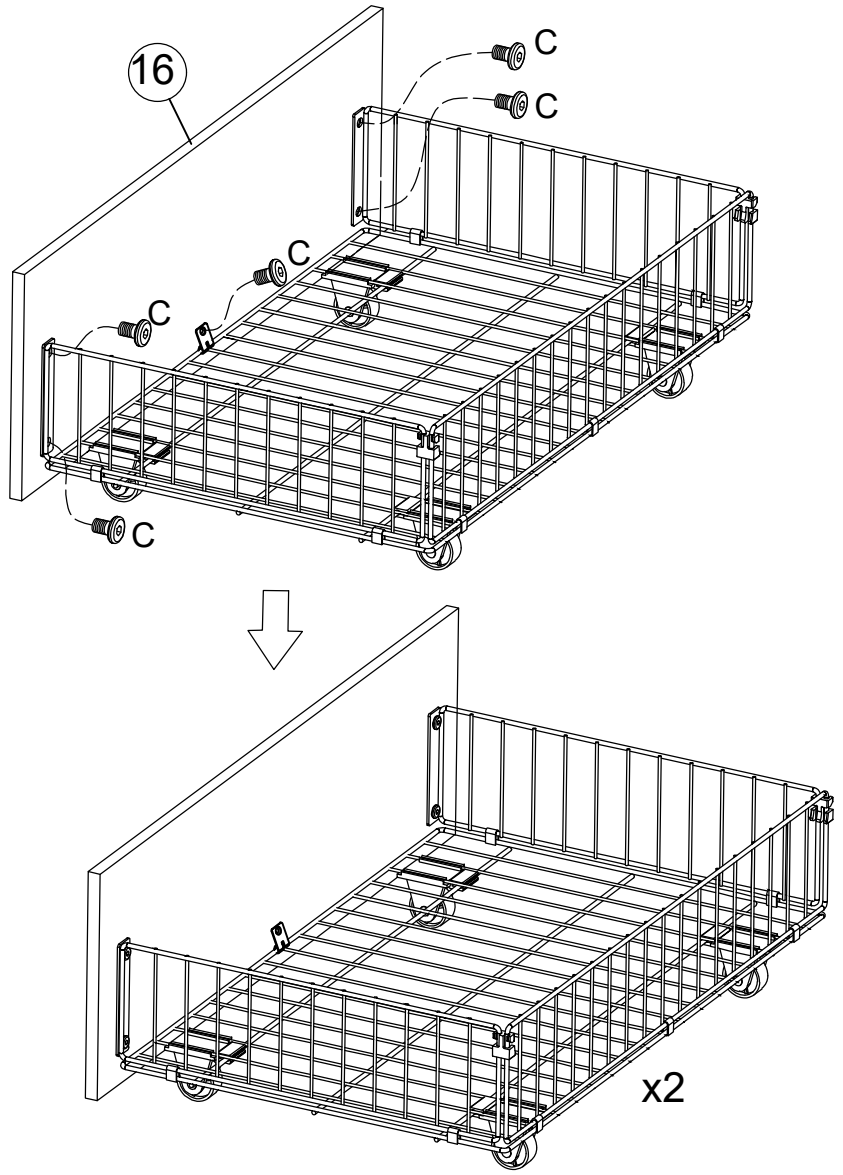

Step:10

