





# ASSEMBLY INSTRUCTIONS

## E.KING BED(5 + 5)

### (BOX 1)

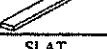
#### BOX OF HEADBOARD

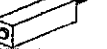
NO	ITEM	QTY
	HEADBOARD	
A		1 PC
	FOOTBOARD	
B		1 PC
	HB LEG L&R	
C		2 PCS
	SLAT	
D		5 PCS
	BED SLAT SUPPORT	
E		5 PCS

### (BOX 2)

#### BOX OF SIDE RAIL

NO	ITEM	QTY
	SIDE RAIL	
F		2 PCS

### (BOX 1)

#### HARDWARE LIST

NO	ITEM	QTY
1	JCBC BOLT M6 x 30MM BLK	6 PCS
2	SPRING WASHER 1/4" RBW	6 PCS
3	FLAT WASHER 1/4" ID x 13mm OD BLK	6 PCS
4	ALLEN KEY m4 x 65mm BLK	1 PC
5	FLAT HEAD CHIPBOARD SCREW m4 x 32mm RBW	10 PCS

**STEP 1 :** Attach Head Board Leg ( C ) to Head Board ( A ) as shown using JCBC BOLT( 1 )with Spring Washer ( 2 ), Flat washer ( 3 ) and securing with ALLEN KEY ( 4 ).

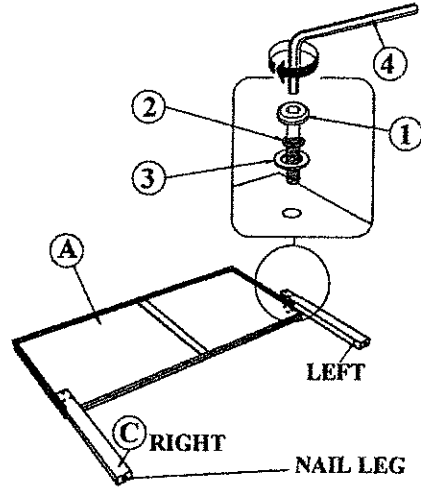

**STEP 2 :** Hook SIDE RAIL ( F ) TO HEAD BOARD ( A ) closely and push down to fit. repeat step 2 with other end of rail to hook onto FOOTBOARD ( B ).

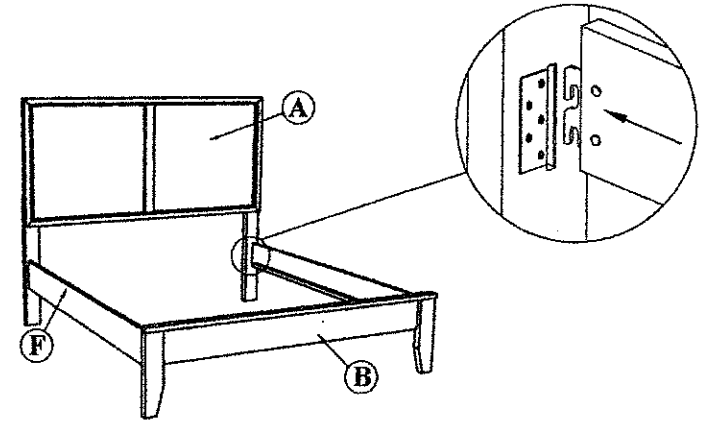

**STEP 3 :** Fix the Bed Slats Support ( E ) to Bed Slats ( D ) as Shown and fix the Bed Slats to Side Rail ( F ) by using Flat Head Chipboard Screw ( 5 ). Loosen or Tighten the Adjuster as necessary to level the bed. Bed assembly should be done in final location to ensure stability.

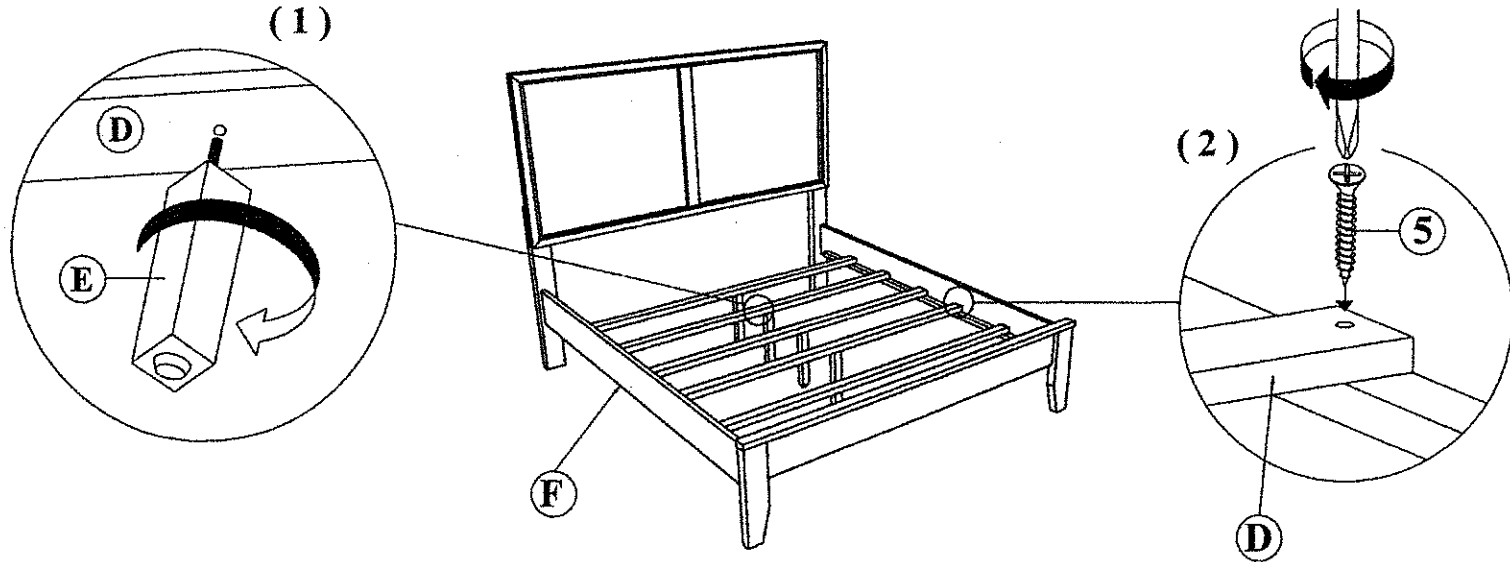

**NOTE :** MUST TIGHTEN SCREWS PERIODCALLY WITH USE SCREW WILL BECOME LOOSE CHECK TIGHTNESS OF ALL SCREW EVERY 6-8 WEEKS.