

# **U-shape Burl Wood Coffee Table**

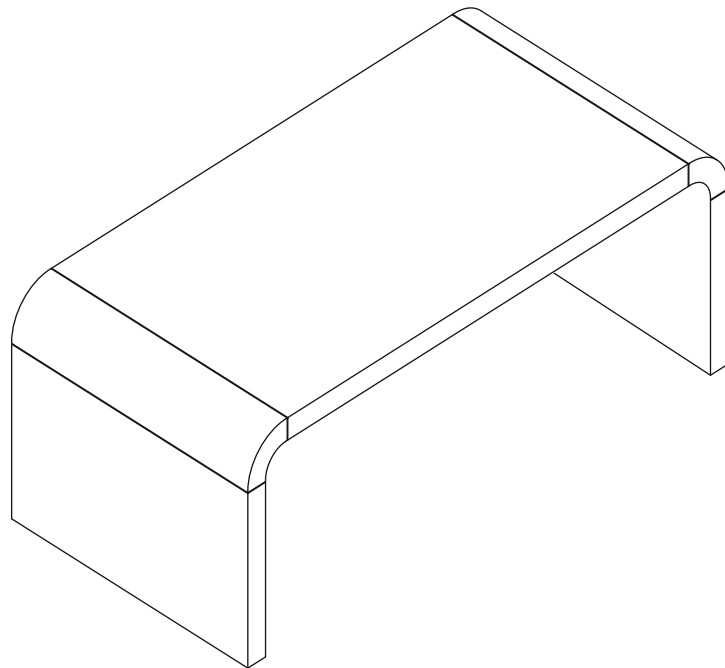

# NOTICE

---

**Please keep these instructions for future reference.**

**Dear Customer**

● Thank you for your purchase. When you receive the product, please make sure that all the parts are intact. If any parts are missing, please contact us promptly to request replacement parts.

● Then follow the entire installation instructions to install.

● Each part is crucial, so please be careful not to lose any. It is recommended to store parts with different lettered identifiers in separate boxes or bags to avoid confusion during installation.

**A** . The outer box is damaged

**B** . The product is damaged / bent / cracked while you open the box









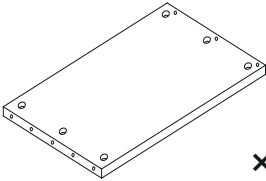
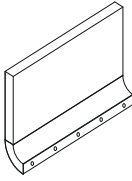

**C** . The parts / accessories / assembly tools are missing

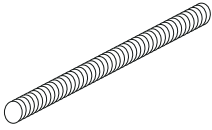
**D** . The instructions are not clear and can not be referred

**E** . The product has functional problems

**F** . Other aspects that you are not satisfied with

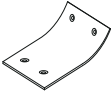
# PART LIST

<b>A</b> Table board  x1	<b>B</b> Side panels  x2	<b>C</b> Wooden tenon  x4	<b>D</b> Full-tooth screw  x6	
<b>E</b> Hexagon nut  x6	<b>F</b> Spring spacers  x6	<b>G</b> Flat spacers  x6	<b>H</b> Half moon spacer  x6	<b>I</b> Hexagon wrench  x1
<b>J</b> Connect  x4	<b>K</b> screws  x16			

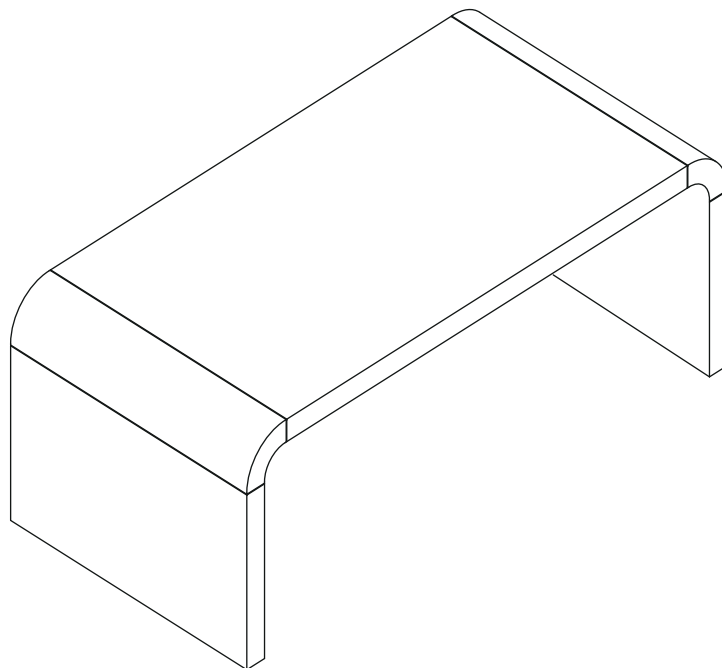

This page lists all the contents included in the box. Please take the time to identify the hardware as well as the individual components to this product. As you unpack and prepare for assembly, place the contents on a carpeted or padded area to protect them from damage.

# STEP

1

1. Wooden tenon [C] is shown in the corresponding [B] hole, Full-tooth screw [D] is tightened in hole [B] as shown in the figure.
2. Once the timber tenon [C] and the full thread screw [D] are installed, insert them into the corresponding holes in the [A] panel.
3. Place the half-moon spacer [H] into the corresponding card slot.

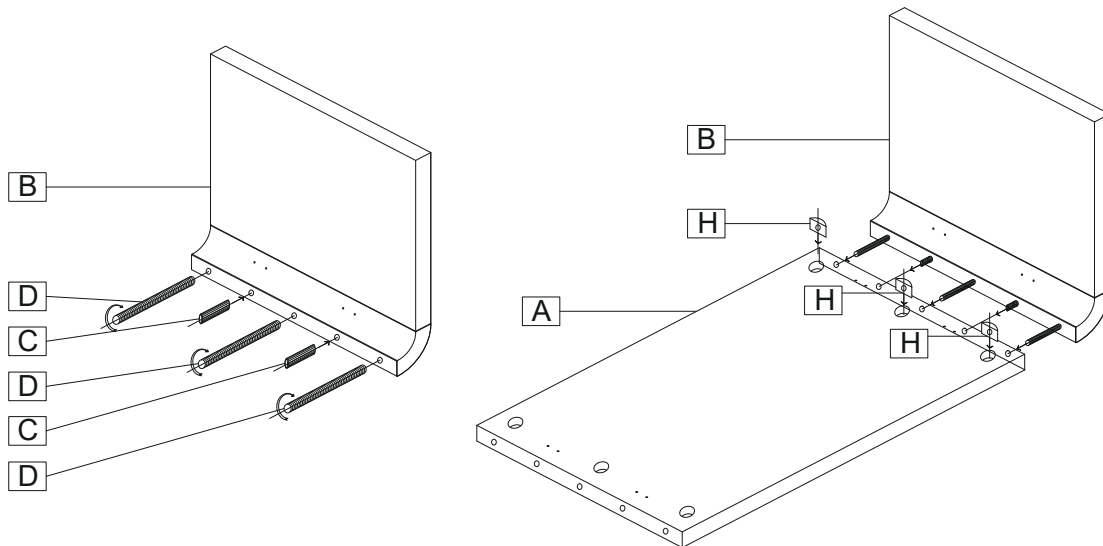

2

1. Insert the [G] flat gasket [F] spring gasket [E] hexagon nut into the [D] full-tooth screw according to the diagram arrangement, tighten it with an [I] hex wrench, connect the iron [J] plate corresponding to the pilot hole, and lock it with the wood screw [K]

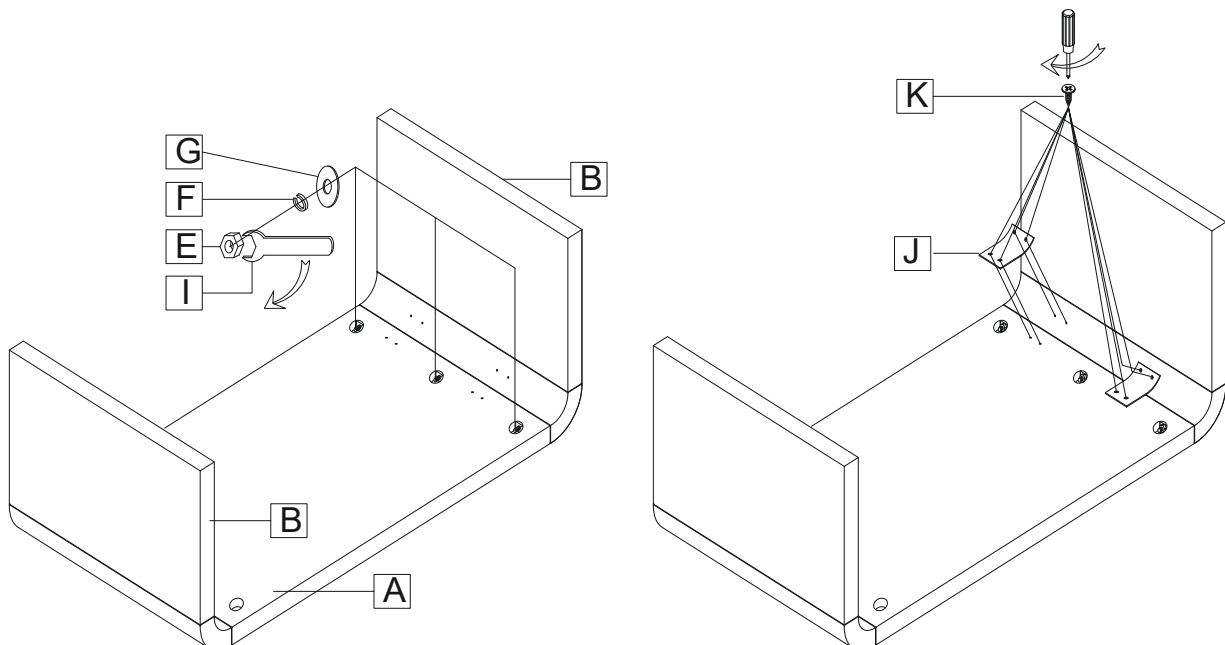

2