

ASSEMBLY INSTRUCTIONS

INSTRUCTIONS DE MONTAGE

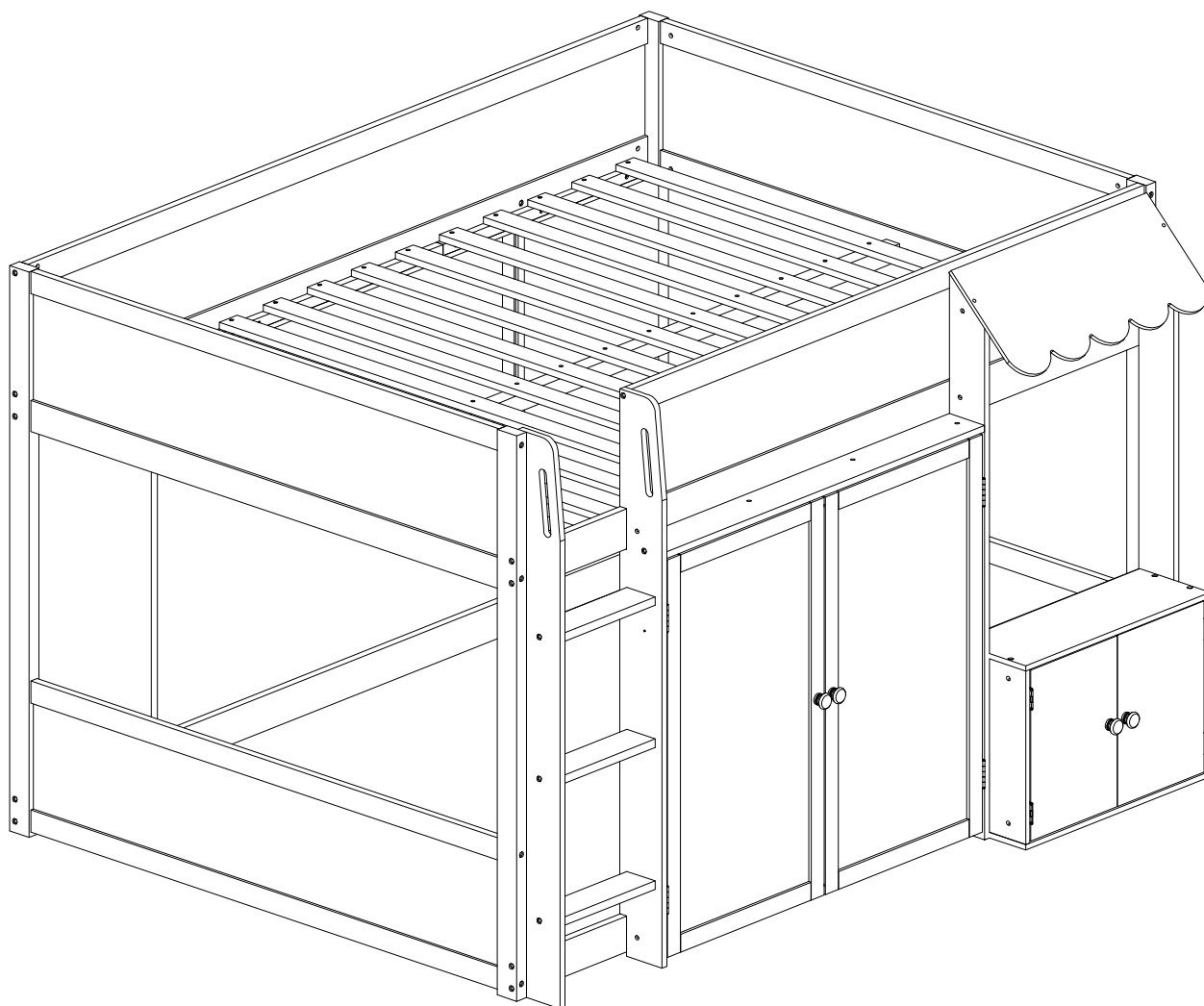

SAFETY WARNING

1. This bed is designed for use only mattress(es) meeting the following specifications on the upper bunk.

Bed Type	Length	Width	Thickness
Full Standard	74" - 75"	53 1/2 "	6"

2. Replacement parts, including additional guardrails, may be obtained from any of our dealers.
3. Follow the information on the warnings appearing on the upper bunk bed end structure and on the carton. Do not remove warning label from bed.
4. Always use the recommended size mattresses or mattress supports, or both, to help prevent the likelihood of entrapment or falls.
5. Surface of the mattress must be at least 5 in. (127 mm) below the upper edge of guardrails.
6. Do not allow children under 6 years of age to use the upper bunk.
7. Periodically check and ensure that the guardrail, ladder, and other components are in their proper position, free from damage, and that all connectors are tight.
8. Do not allow horseplay on or under the bed and prohibit jumping on the bed
9. Always use the ladder for entering and leaving the upper bunk.
10. Do not use substitute parts. Contact the manufacturer or dealer for replacement parts.
11. Use of a night light may provided added safety precaution for a child using the upper bunk.
12. Always use guardrails on both long sides of the upper bunk. If the bunk bed will be placed next to the wall, the guardrail that runs the full length of the bed should be placed against the wall to prevent entrapment between the bed and wall.
13. The use of water or sleep flotation mattresses is prohibited.
14. **STRANGULATION HAZARD** – Never attach or hang items to any part of the bunk bed that are not designed for use with the bed; for example, but not limited to, hook, belts and jump ropes.
15. Keep these instructions for future reference
16. We recommend assembling your bunk bed on a shipping carton to protect your floor or carpet
17. Be certain all staples are out of the box before beginning assembly on the shipping carton
18. Prohibit more than one person on upper bunk

AVERTISSEMENTS DE SÉCURITÉ

1. Ce lit est conçu pour être utilisé uniquement avec des matelas répondant aux spécifications suivantes sur la couchette supérieure.

Type de lit	Longueur	Largeur	Épaisseur
Norme complète	74po - 75po	53 1/2po	6po

2. Des pièces de rechange, y compris des garde-corps supplémentaires, peuvent être obtenues auprès de l'un de nos revendeurs.

3. Suivez les informations figurant sur les avertissements figurant sur la structure d'extrémité du lit superposé supérieur et sur le carton. Ne retirez pas l'étiquette d'avertissement du lit.

4. Utilisez toujours des matelas ou des supports de matelas de taille recommandée, ou les deux, pour éviter tout risque de piégeage ou chutes.

5. La surface du matelas doit être à au moins 5 po (127 mm) sous le bord supérieur des barrières de sécurité.

6. Ne laissez pas les enfants de moins de 6 ans utiliser la couchette supérieure.

7. Vérifiez et assurez-vous périodiquement que le garde-corps, l'échelle et les autres composants sont dans leur position appropriée, exempt de dommages et que tous les connecteurs sont bien serrés.

8. Ne permettez pas les jeux brutaux sur ou sous le lit et interdisez de sauter sur le lit.

9. Utilisez toujours l'échelle pour entrer et sortir de la couchette supérieure.

10. N'utilisez pas de pièces de rechange. Contactez le fabricant ou le revendeur pour obtenir des pièces de rechange.

11. L'utilisation d'une veilleuse peut constituer une mesure de sécurité supplémentaire pour un enfant utilisant la couchette supérieure.

12. Utilisez toujours des barrières de sécurité sur les deux côtés longitudinaux du lit supérieur. Si le lit superposé doit être placé à côté du mur, la barrière de sécurité qui s'étend sur toute la longueur du lit doit être placée contre le mur pour éviter tout piégeage entre le lit et le mur.

13. L'utilisation de matelas à eau ou de matelas flottants pour le sommeil est interdite.

14. **RISQUE D'ÉTRANGLEMENT** - Ne jamais attacher ou suspendre des objets à une partie quelconque du lit superposé qui ne sont pas conçu pour être utilisé avec le lit ; par exemple, mais sans s'y limiter, un crochet, des ceintures et des cordes à sauter.

15. Conservez ces instructions pour référence ultérieure.

16. Interdire à plus d'une personne de dormir sur la couchette supérieure.







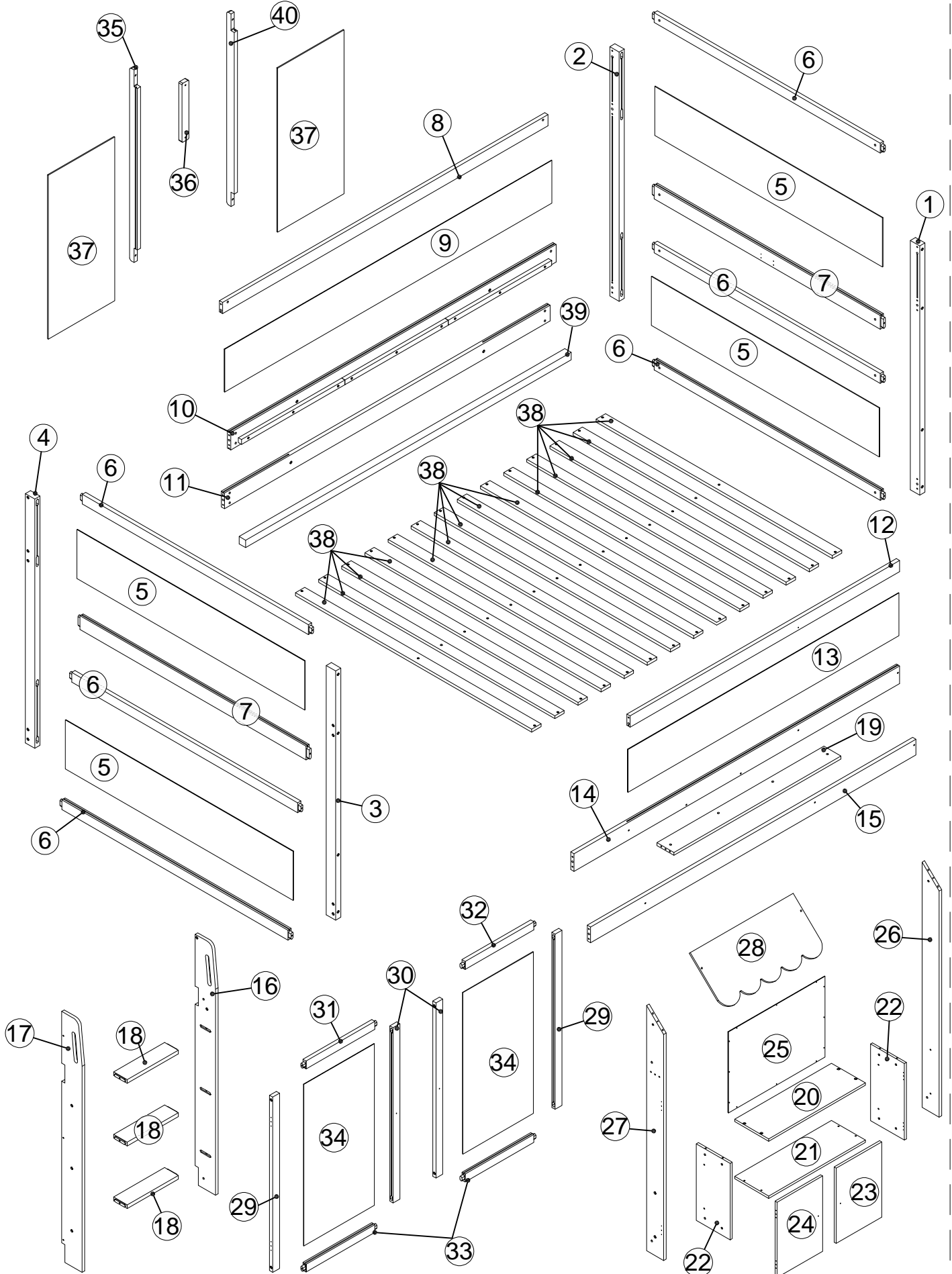



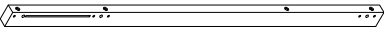

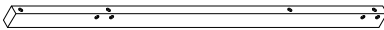
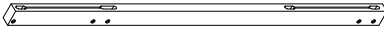

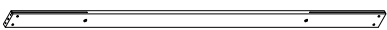

17. Nous vous recommandons d'assembler votre lit superposé sur le carton d'expédition pour protéger votre sol ou votre tapis.

18. Assurez-vous que toutes les agrafes sont sorties de la boîte avant de commencer l'assemblage sur le carton d'expédition.

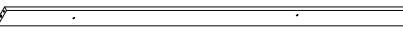

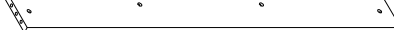







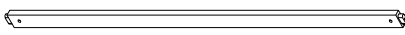

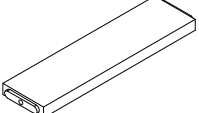





Detail View - Vue détaillée

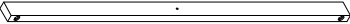

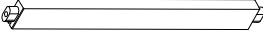

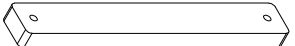









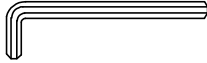

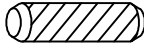

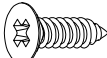
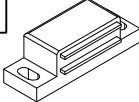

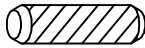
Part Lists - Listes de pièces

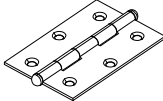
		
<p>Right front leg / Pied avant droit 1pc/pièce</p>	<p>Right back leg/ Pied arrière droit 1pc/pièce</p>	<p>Left front leg/ Pied avant gauche 1pc/pièce</p>
		
<p>Left back leg/ Pied arrière gauche 1pc/pièce</p>	<p>Rear guardrail/ Garde-corps arrière (1pc/pièce)</p>	<p>Back panel Panneau arrière 1pc/pièce</p>
		
<p>Rear bed rail Longeron arrière du lit (1pc/pièce)</p>	<p>Lower rear rail/ Traverse arrière inférieure (1pc/pièce)</p>	<p>Front guardrail Garde-corps avant (1pc/pièce)</p>
		
<p>Front panel/ Panneau avant (1pc/pièce)</p>	<p>Front bed rail Longeron avant du lit (1pc/pièce)</p>	<p>Lower front rail/ Traverse avant inférieure (1pc/pièce)</p>
		
<p>Right stair post Montant d'escalier droit (1pc/pièce)</p>	<p>Left stair post/ Montant d'escalier gauche (1pc/pièce)</p>	<p>Bed board / Planche de lit (1pc/pièce)</p>
		
<p>Front left upright / Montant avant gauche (1pc/pièce)</p>	<p>Front right upright/ Montant avant droit (1pc/pièce)</p>	<p>Middle slat support/ Support central de lattes (1pc/pièce)</p>

Part Lists - Listes de pièces

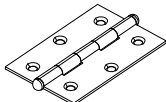
<p>⑤</p> 	<p>⑥</p> 	<p>⑦</p> 
<p>Side panel Panneau latéral 4pcs/pièces</p>	<p>Side rail/ Traverse latérale 6 pcs/pièces</p>	<p>Side rail/ Traverse latérale 2 pcs/pièces</p>
<p>⑱</p> 	<p>⑳</p> 	<p>㉑</p> 
<p>Stair step/ Marche d'escalier (3pcs/pièces)</p>	<p>Top panel/ Panneau supérieur (1pc/pièce)</p>	<p>Bottom panel/ Panneau inférieur (1pc/pièce)</p>
<p>㉒</p> 	<p>㉓</p> 	<p>㉔</p> 
<p>Side panel/ Panneau latéral 2pcs/pièces</p>	<p>Right wardrobe door/ Porte d' armoire droite (1pc/pièce)</p>	<p>Left wardrobe door/ Porte 'armoire gauche (1pc/pièce)</p>
<p>㉕</p> 	<p>㉘</p> 	<p>㉙</p> 
<p>Wardrobe back panel Panneau arrière d'armoire (1pc/pièce)</p>	<p>Roof panel Panneau de toit (1pc/pièce)</p>	<p>Door upright / Montant de porte 2pcs/pièces</p>
<p>㉚</p> 	<p>㉛</p> 	<p>㉜</p> 
<p>Door upright / Montant de porte 2pcs/pièces</p>	<p>Door frame crossbar/ Traverse du cadre de porte (1pc/pièce)</p>	<p>Door frame crossbar/ Traverse du cadre de porte (1pc/pièce)</p>
<p>㉞</p> 	<p>㉟</p> 	<p>㊱</p> 
<p>Door frame crossbar/ Traverse du cadre de porte (2pcs/pièce)</p>	<p>Middle door panel/Panneau central de porte (2pcs/pièces)</p>	<p>Left rear upright/ Montant arrière gauche (1pc/pièce)</p>
<p>㊲</p> 	<p>㊳</p> 	<p>㊴</p> 
<p>Guardrail upright Montant du garde-corps (1pc/pièce)</p>	<p>Lower back panel/ Panneau arrière inférieur (2pcs/pièces)</p>	<p>Slat/ Latte 14pcs/pièces</p>
<p>㊵</p> 		
<p>Right rear upright/ Montant arrière droit (1pc/pièce)</p>		

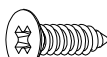
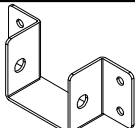
Hardware Lists - Listes de matériel

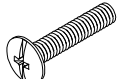
<p>A</p>  <p>Ø1/4"*90mm</p>	<p>B</p>  <p>Ø1/4"*9.5*12mm</p>	<p>C</p>  <p>K4mm</p>
<p>Hex-Head bolt/Boulon à tête hexagonale (16 pcs/pièces)</p>	<p>Hex-Head bolt/Boulon à tête hexagonale (70 pcs/pièces)</p>	<p>Allen key/Clé Allen (2pcs/pièces)</p>
<p>D</p>  <p>Ø1/4"*70mm</p>	<p>E</p>  <p>Ø10*30mm</p>	<p>F</p>  <p>Ø1/4"*50mm</p>
<p>Hex-Head bolt/Boulon à tête hexagonale (19 pcs/pièces)</p>	<p>Wood dowel/Cheville en bois (12 pcs/pièces)</p>	<p>Hex-Head bolt/Boulon à tête hexagonale (27 pcs/pièces)</p>
<p>G</p>  <p>#3*12mm</p>	<p>H H1</p>  	<p>I</p>  <p>Ø8*30mm</p>
<p>Screw/Vis (64pcs/pièces)</p>	<p>(4 set/ensemble)</p>	<p>Wood dowel/Cheville en bois (8 pcs/pièces)</p>
<p>J</p>  <p>Ø6*35mm</p>	<p>K</p> 	<p>L</p>  <p>Ø1/4"*15mm</p>
<p>Hex-Head screw/Vis à tête hexagonale (5pcs/pièces)</p>	<p>Leaf hinge/Charnière à battant (4pcs/pièces) L48mm</p>	<p>Nut/Noix (8pcs/pièces)</p>
<p>M</p>  <p>Ø1/4"*20mm</p>	<p>N</p>  <p>Ø1/4"*80mm</p>	<p>O</p> 
<p>Hex-Head bolt/Boulon à tête hexagonale (4 pcs/pièces)</p>	<p>Hex-Head bolt/Boulon à tête hexagonale (8 pcs/pièces)</p>	<p>Leaf hinge/Charnière à battant (4pcs/pièces) L60mm</p>
<p>P</p>  <p>Ø1/4"*35mm</p>	<p>Q</p>  <p>#3.5*15mm</p>	<p>R</p> 
<p>Hex-Head bolt/Boulon à tête hexagonale (4 pcs/pièces)</p>	<p>Screw/Vis (24pcs/pièces)</p>	<p>Pass U/Passe U (2pcs/pièces)</p>
<p>S</p>  <p>#4*30mm</p>	<p>Y</p> 	<p>Z</p>  <p>5/32"*22mm</p>
<p>Screw/Vis (43pcs/pièces)</p>	<p>Turned knob/Bouton tourné 4 pcs/pièces</p>	<p>Handle bolt/Boulon de poignée 4 pcs/pièces</p>

ASSEMBLY TOOLS REQUIRED (NOT INCLUDED)



PLEASE BE CAREFUL DO NOT DAMAGE THE HOLE POSITION WHEN YOU USE POWER TOOLS !



ATTENTION À NE PAS ENDOMMAGER LA POSITION DU TROU LORSQUE VOUS UTILISEZ DES OUTILS ÉLECTRIQUES !

Step/Étape 1

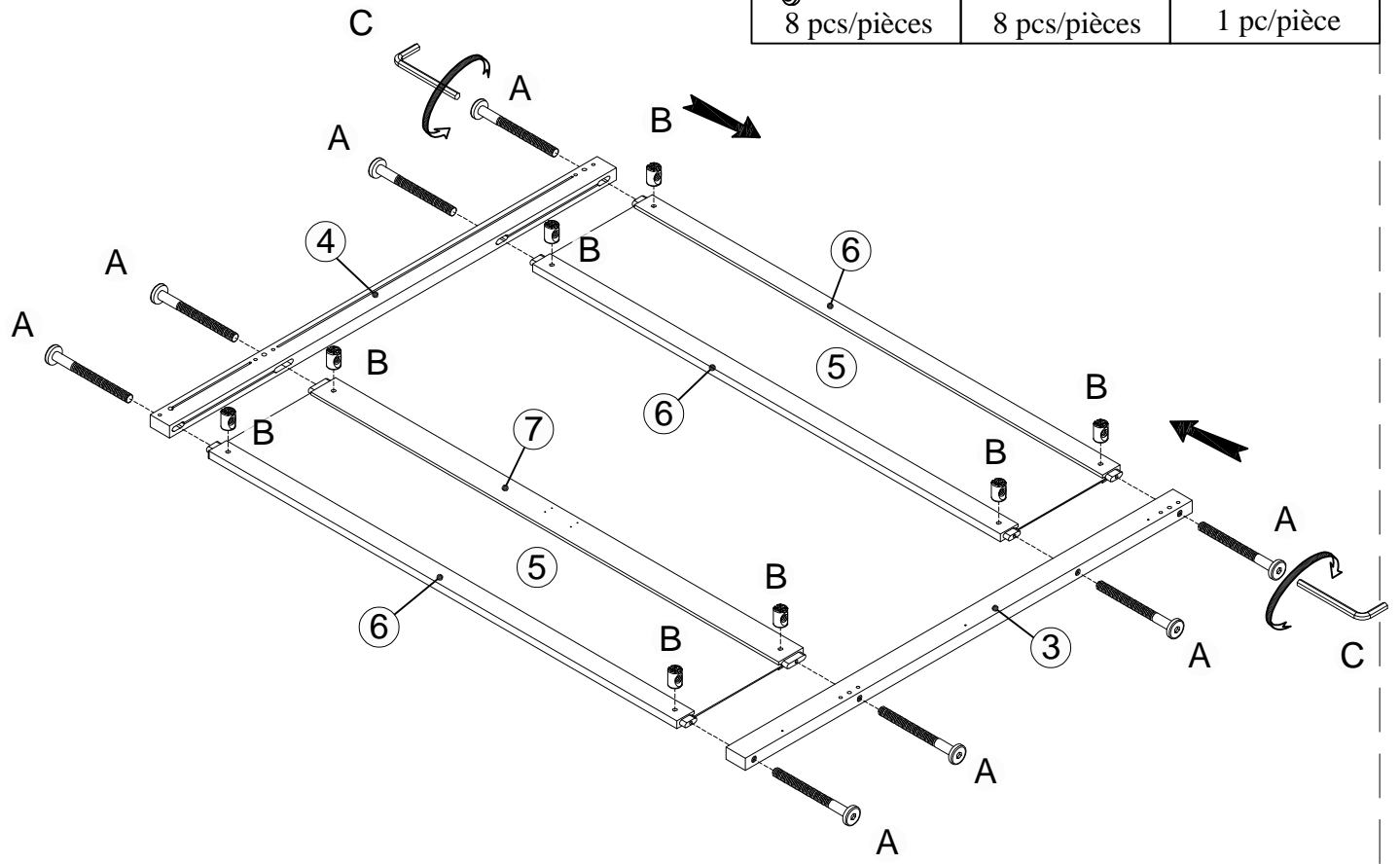
<p>A</p>  <p>8 pcs/pièces</p>	<p>B</p>  <p>8 pcs/pièces</p>	<p>C</p>  <p>1 pc/pièce</p>
--	---	---



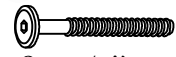

Step/Étape 2

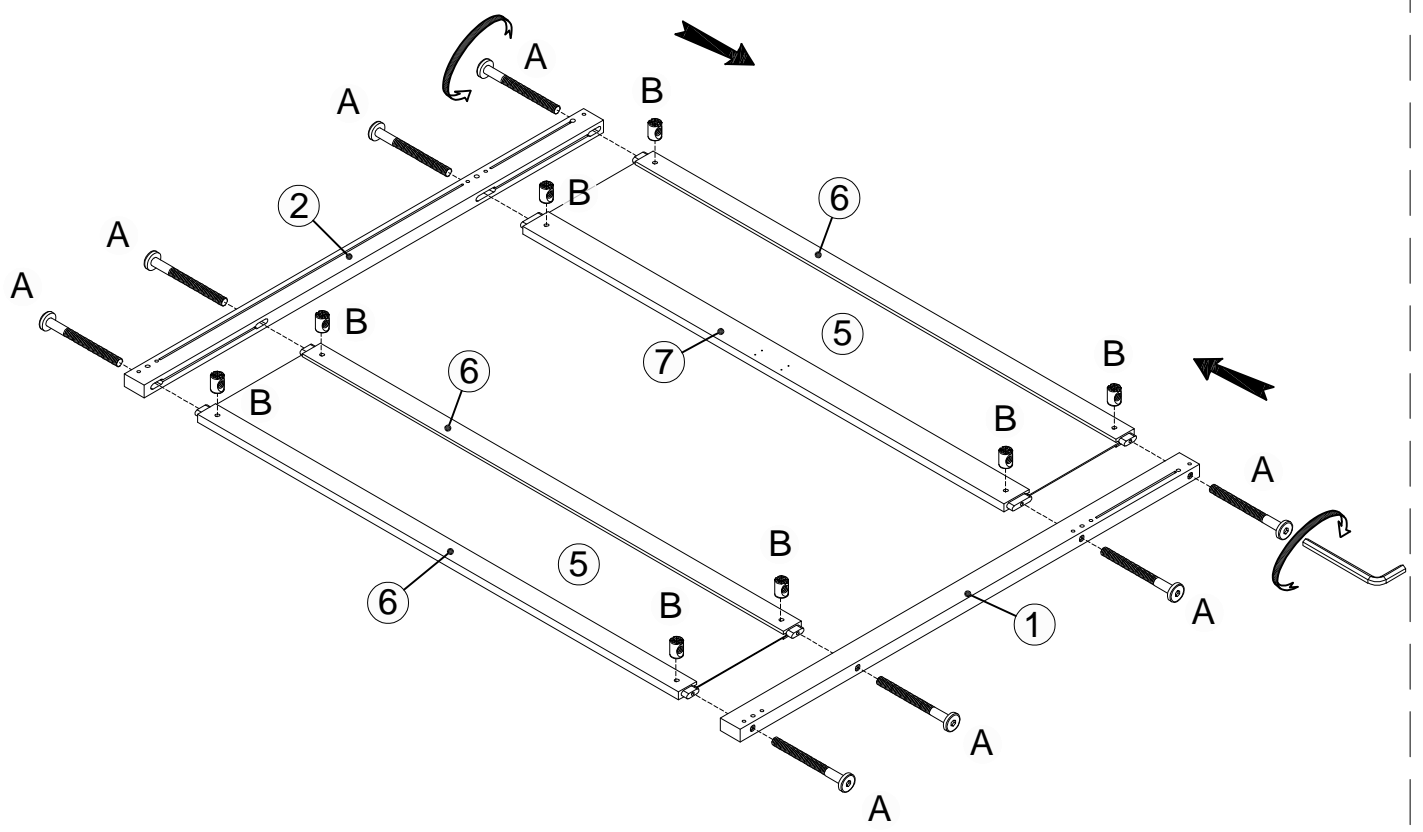
<p>A</p>  <p>8 pcs/pièces</p>	<p>B</p>  <p>8 pcs/pièces</p>	<p>C</p>  <p>1 pc/pièce</p>
--	---	---

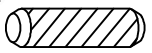

Step/Étape 3

<p>D</p>  <p>18 pcs/pièces</p>	<p>B</p>  <p>18 pcs/pièces</p>	<p>C</p>  <p>1 pc/pièce</p>	<p>E</p>  <p>10 pcs/pièces</p>
--	---	---	--

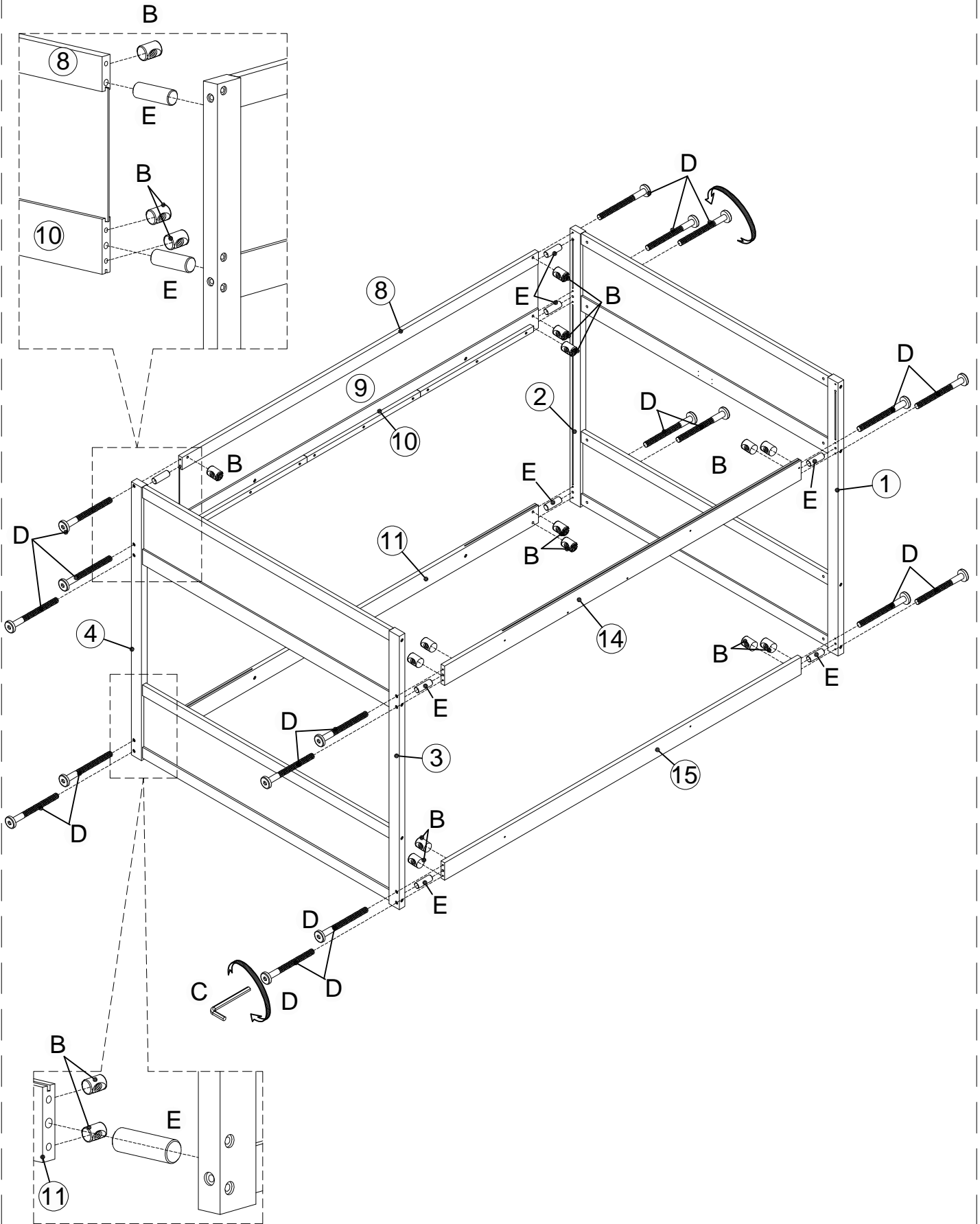



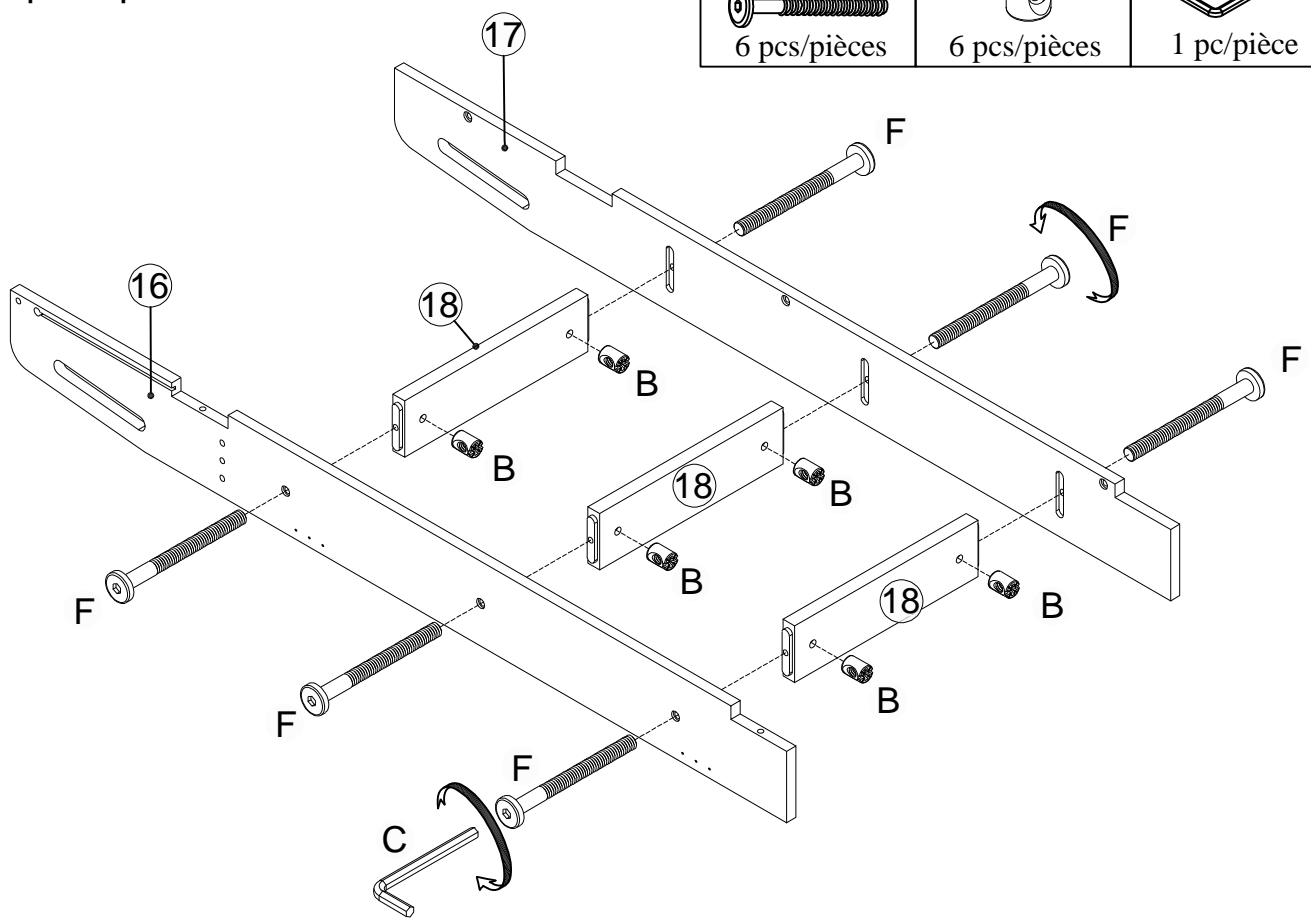

Step/Étape 4

F  6 pcs/pièces	B  6 pcs/pièces	C  1 pc/pièce
--	---	---

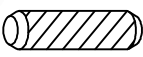

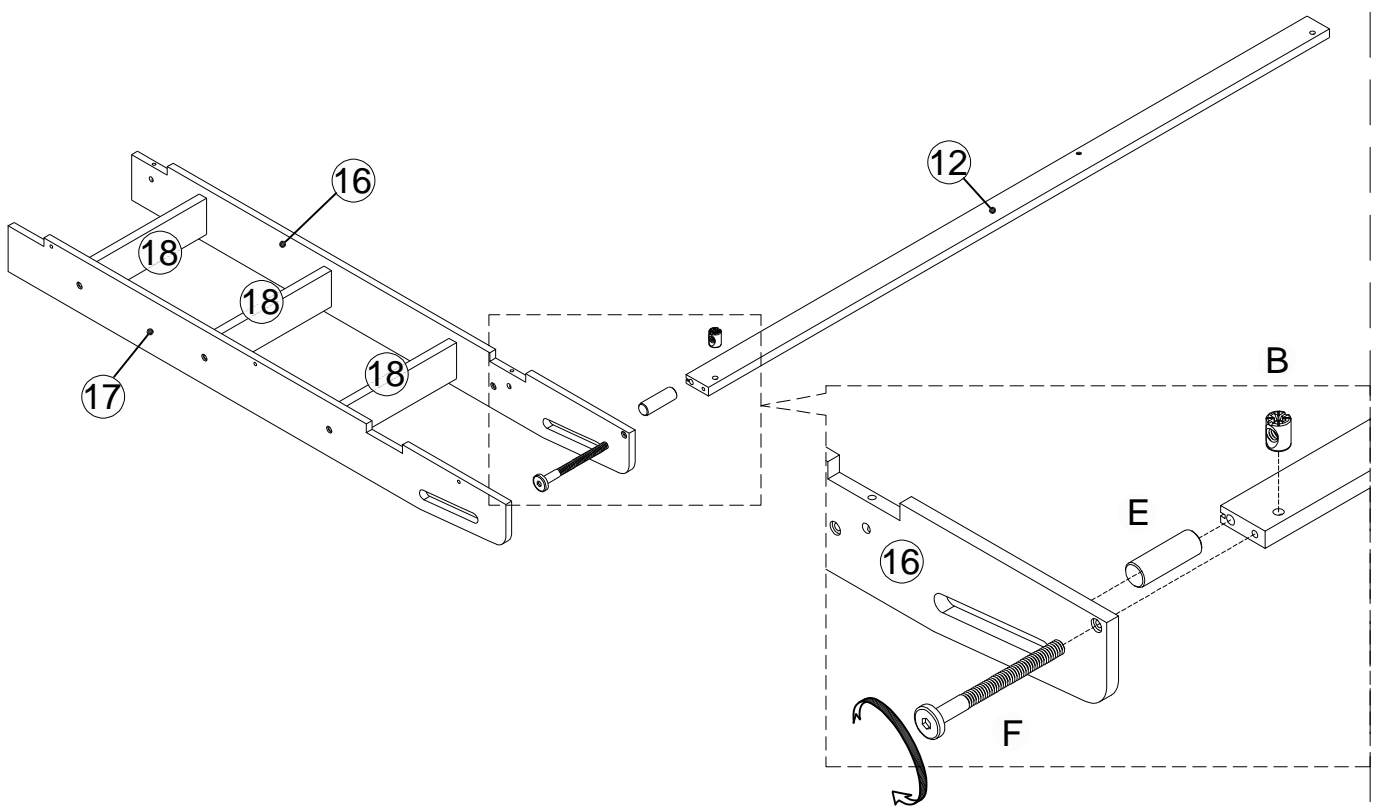

Step/Étape 5

E  1 pc/pièce	F  1 pc/pièce	B  1 pc/pièce	C  1 pc/pièce
---	--	---	---



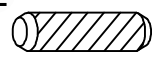

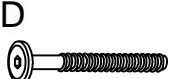
Step/Étape 6

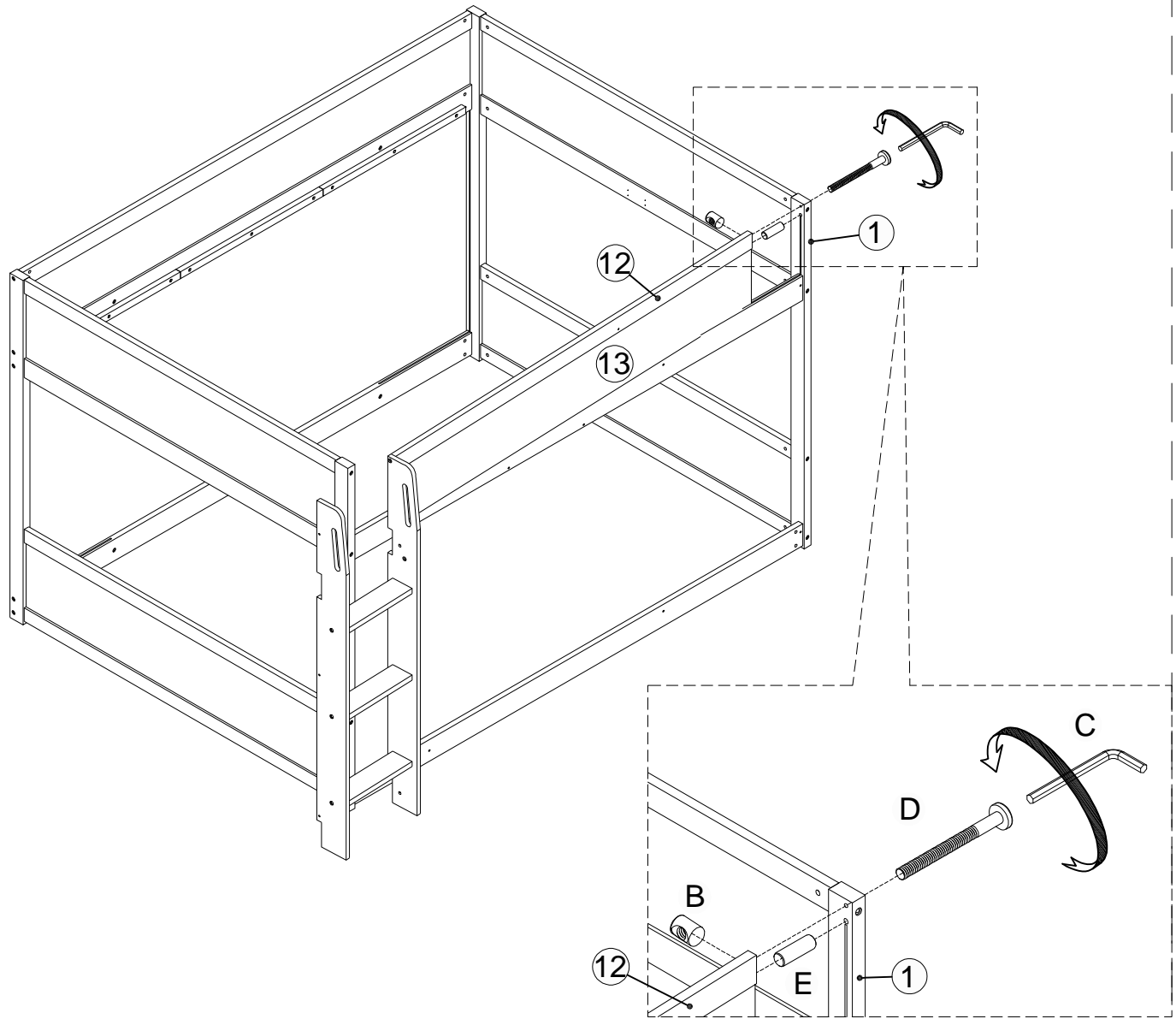
B  1 pc/pièce	E  1 pc/pièce	C  1 pc/pièce	D  1 pc/pièce
---	--	---	---

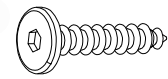

Step/Étape 7

F  2 pcs/pièces	B  2 pcs/pièces	C  1 pc/pièce
J  3 pcs/pièces		

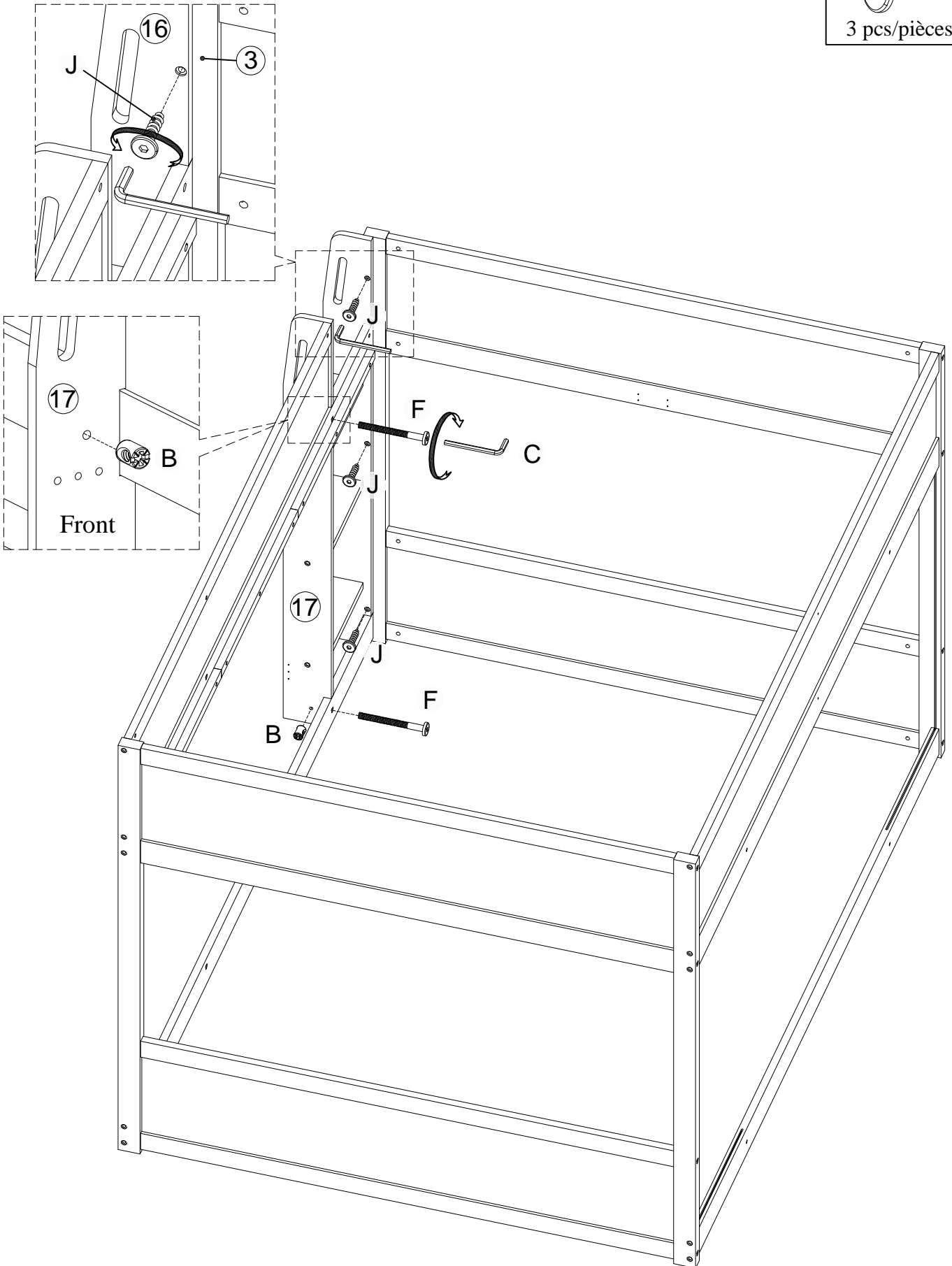

Step/Étape 8

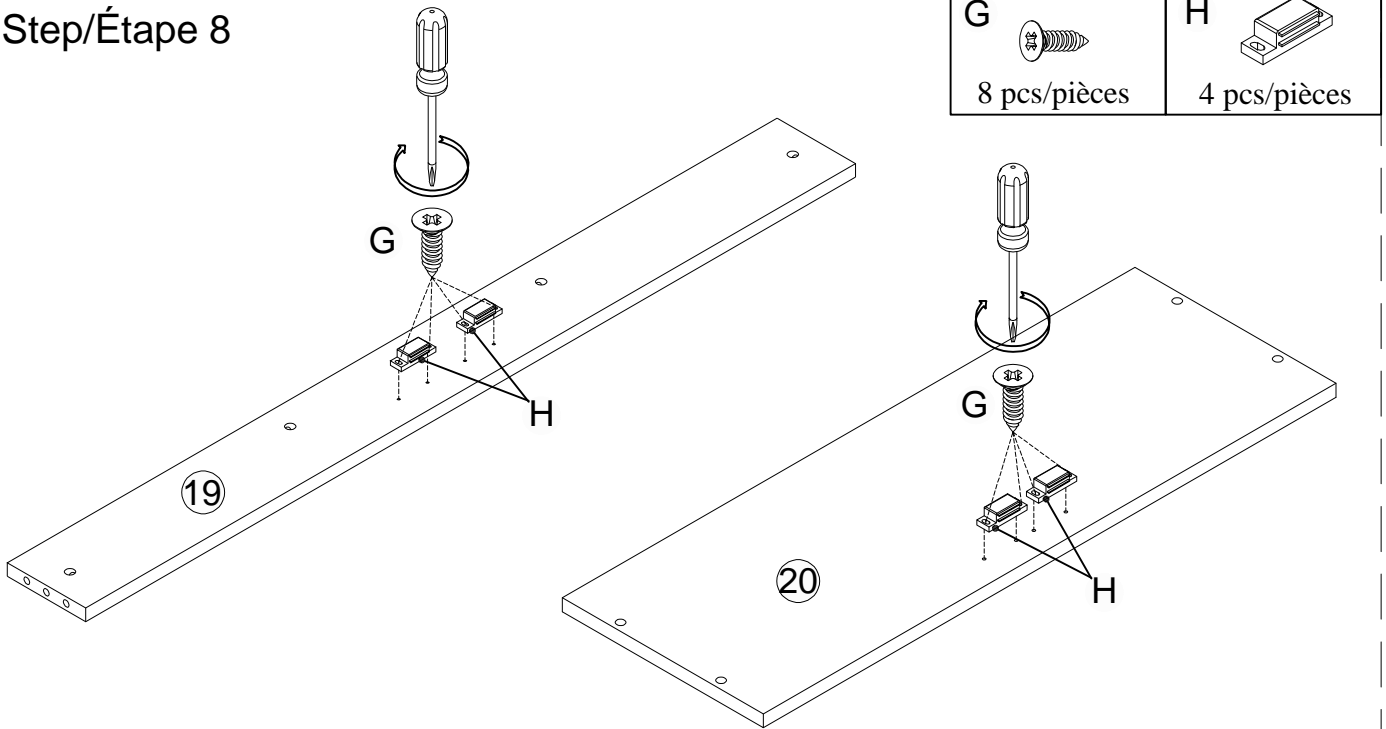

Step/Étape 9

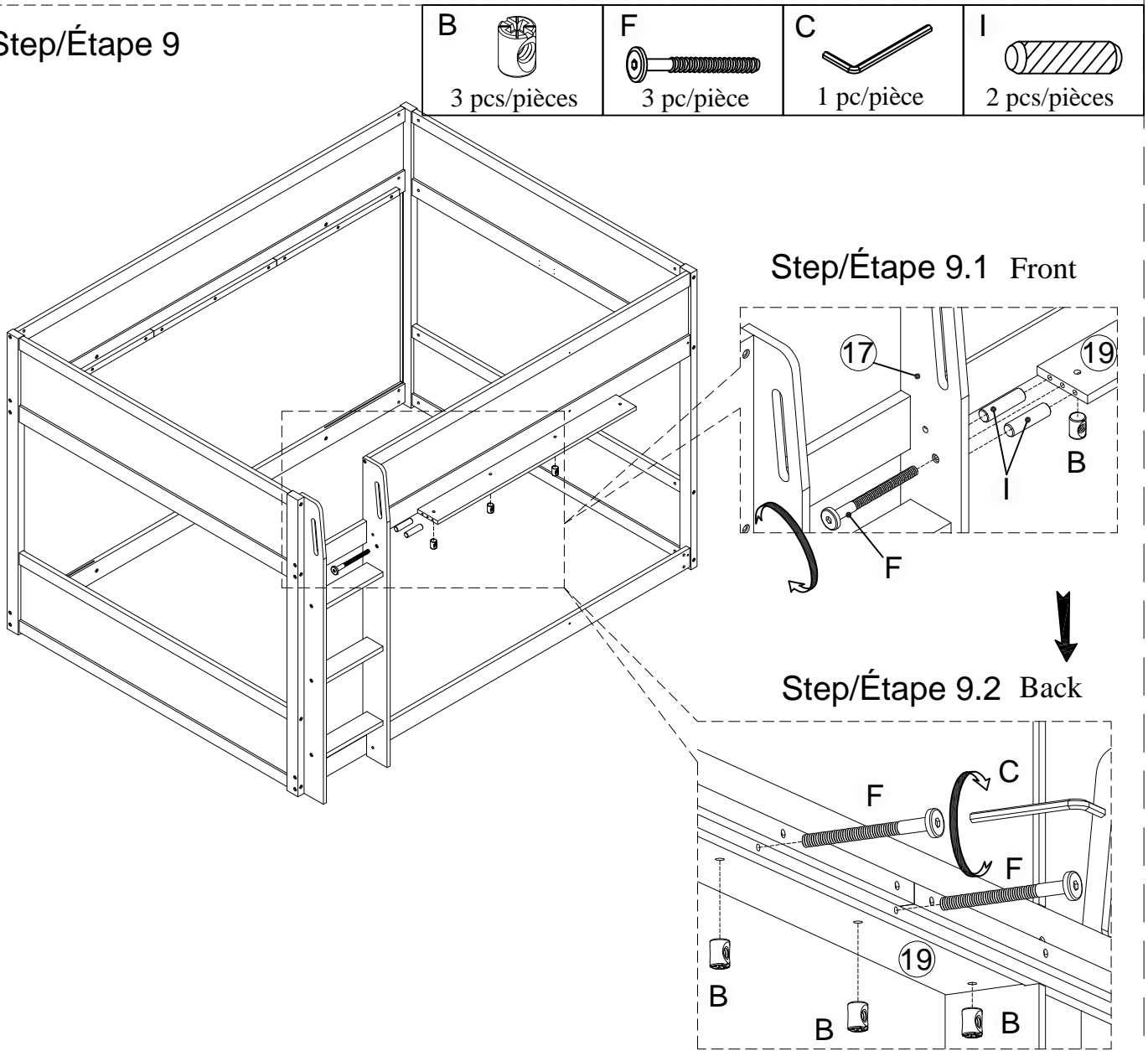

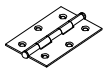

Step/Étape 10

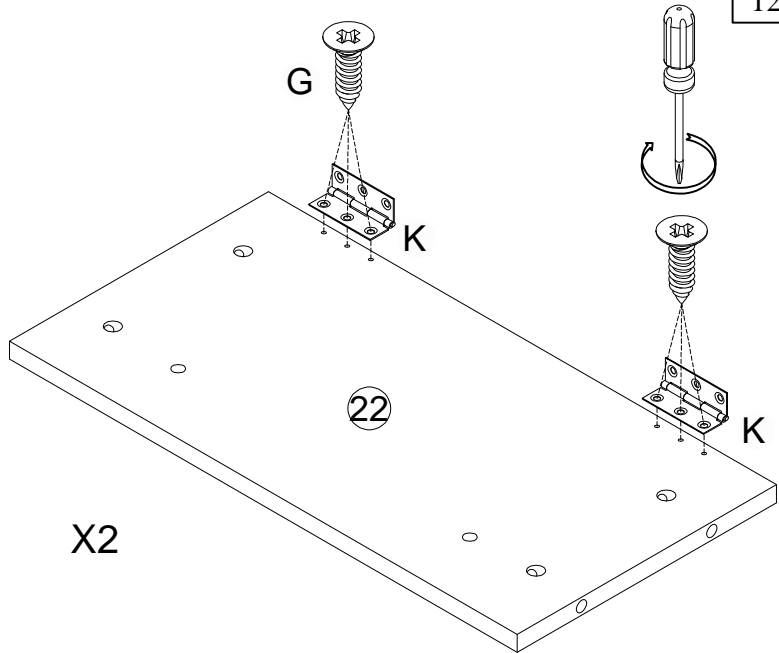
<p>G</p>  <p>12 pcs/pièces</p>	<p>K</p>  <p>4 pcs/pièces</p>
--	---



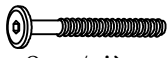

Step/Étape 11

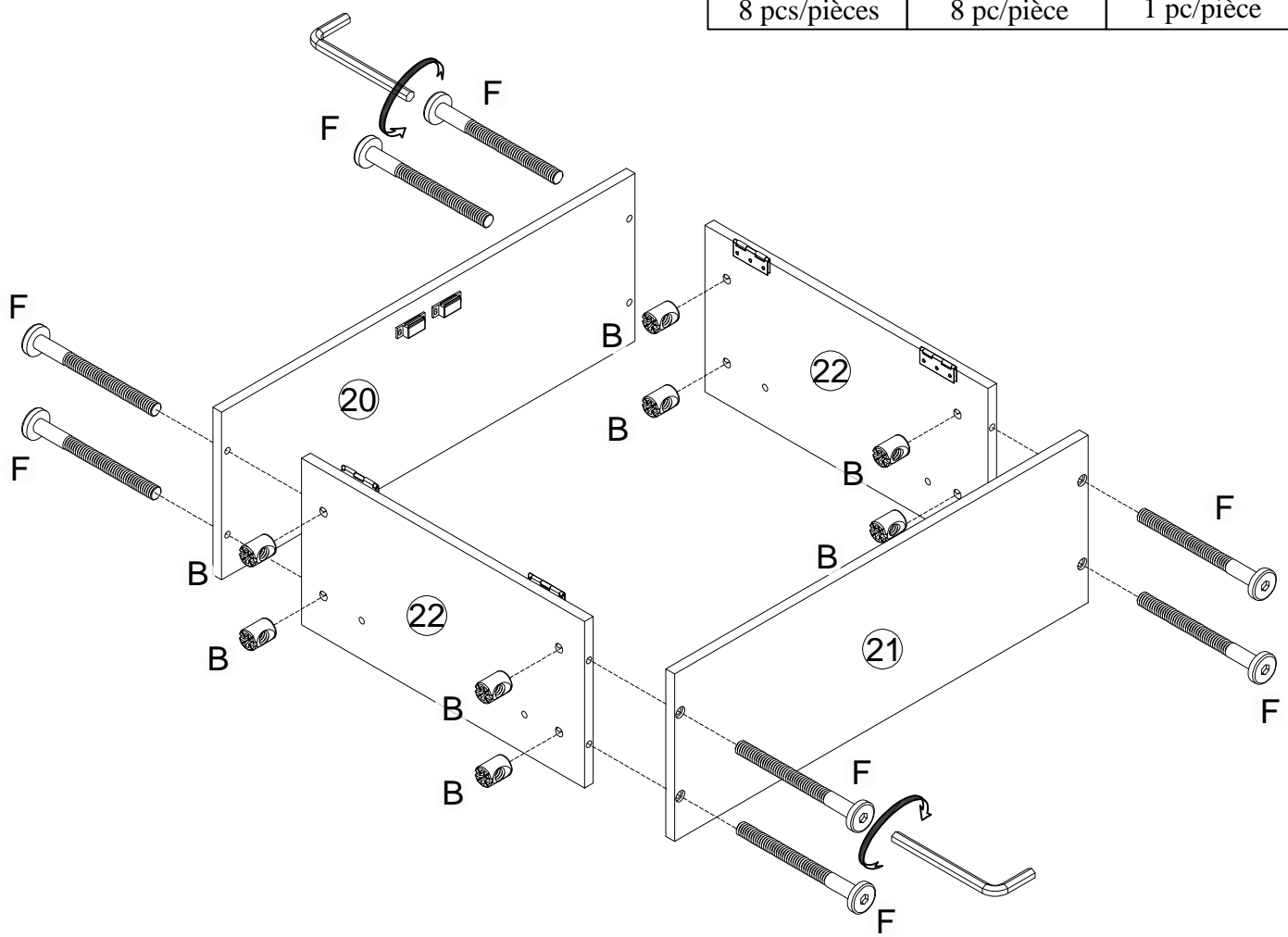
<p>B</p>  <p>8 pcs/pièces</p>	<p>F</p>  <p>8 pc/pièce</p>	<p>C</p>  <p>1 pc/pièce</p>
--	--	--



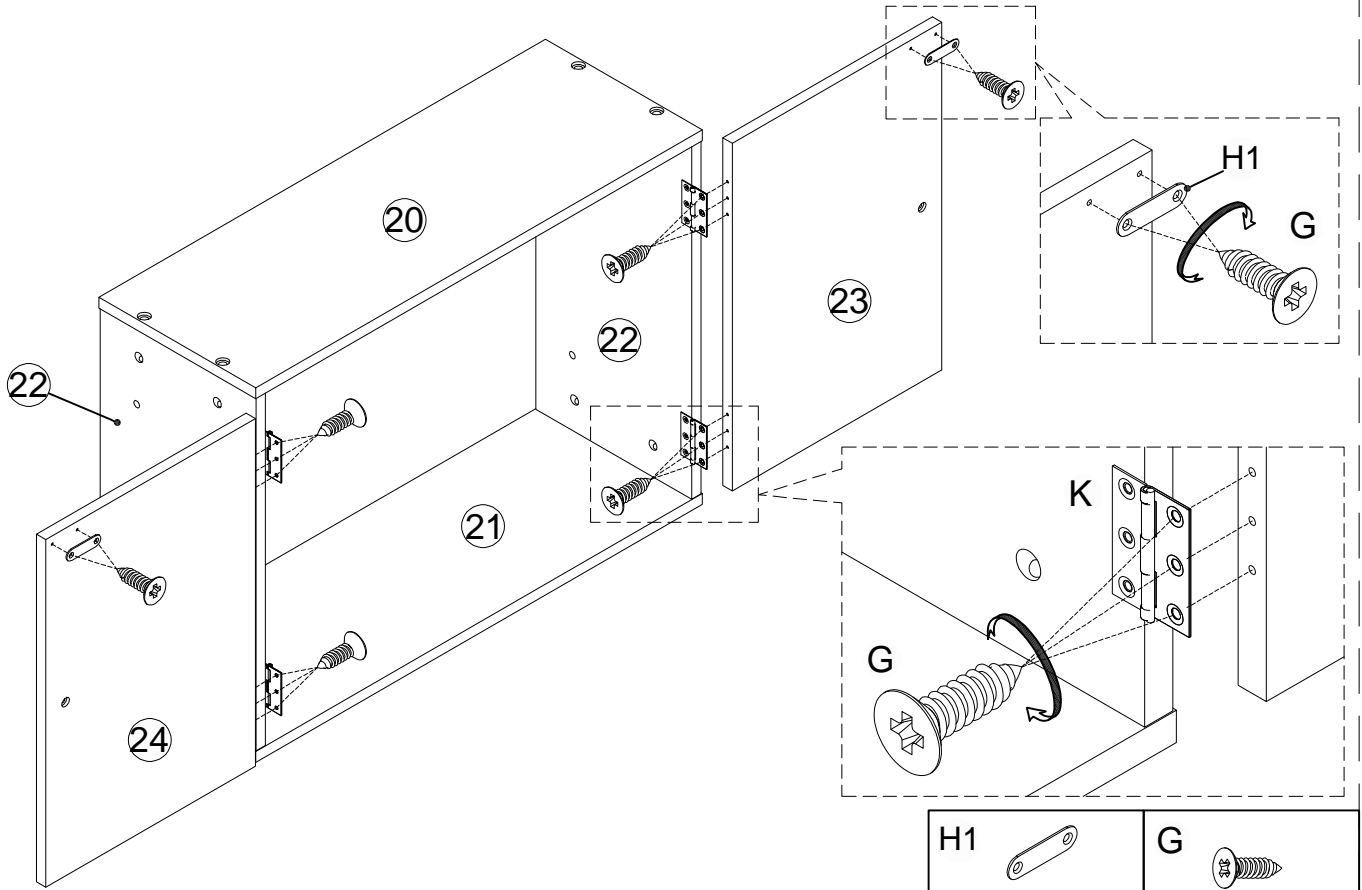

Step/Étape 12



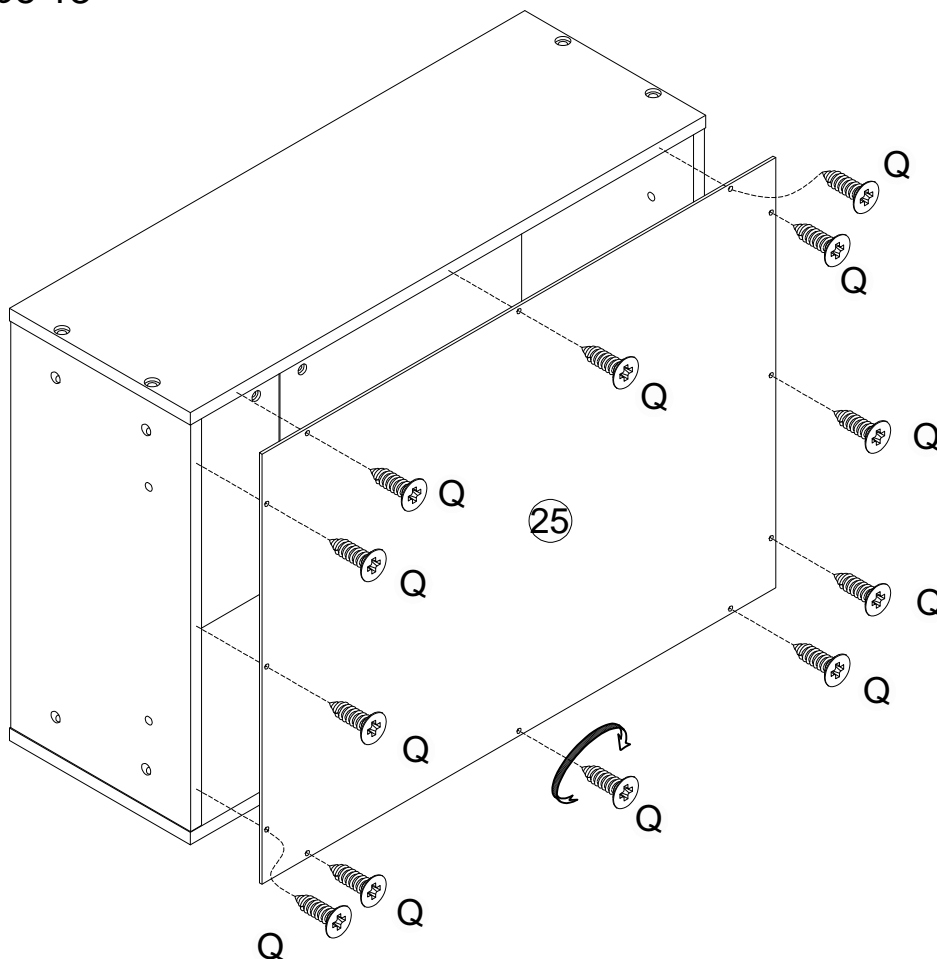

H1		G	
2 pcs/pièces		16 pcs/pièces	

Step/Étape 13





Q	
12 pcs/pièces	

Step/Étape 14

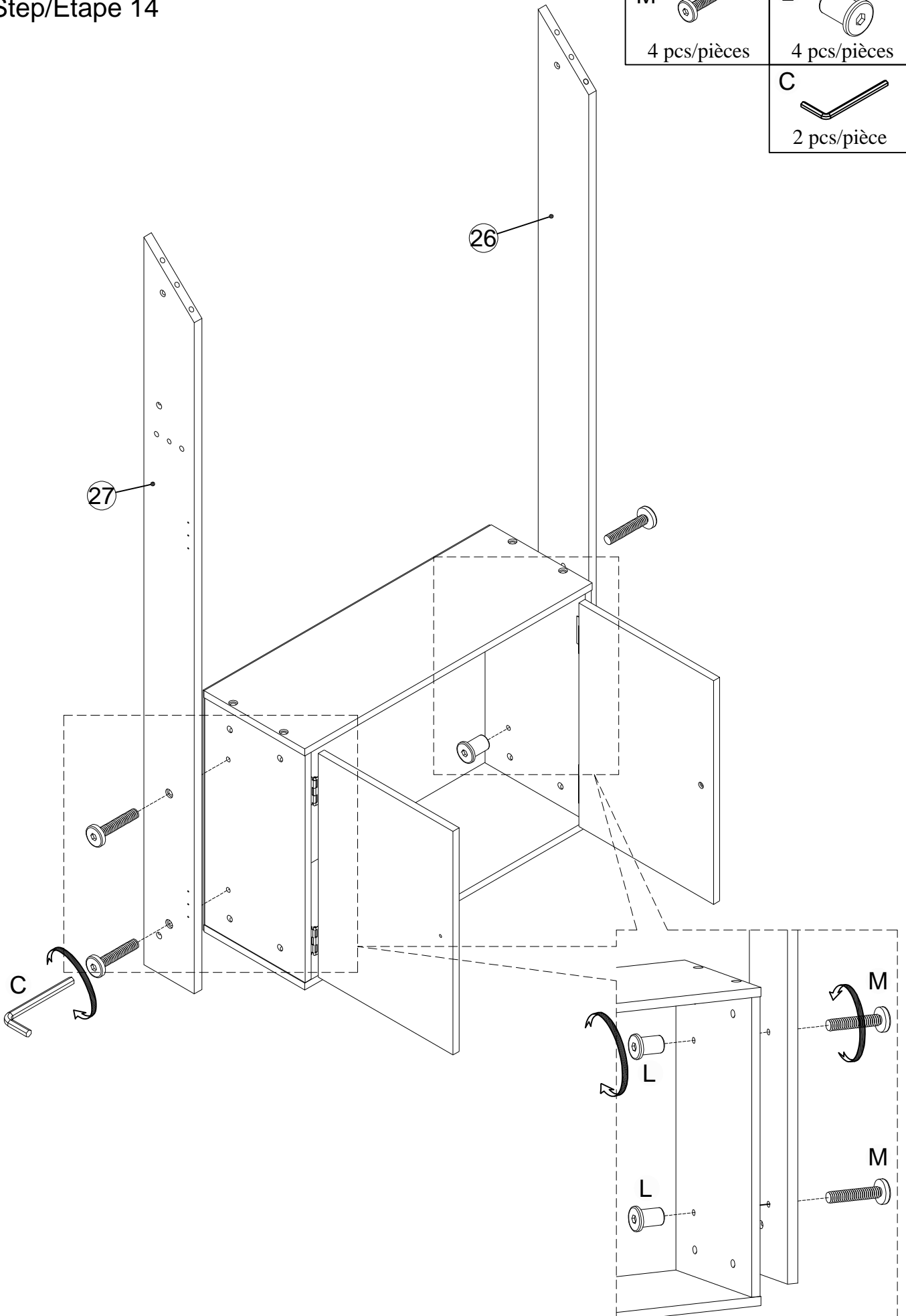
M		L	
4 pcs/pièces		4 pcs/pièces	
		C	
		2 pcs/pièce	



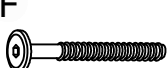

Step/Étape 15

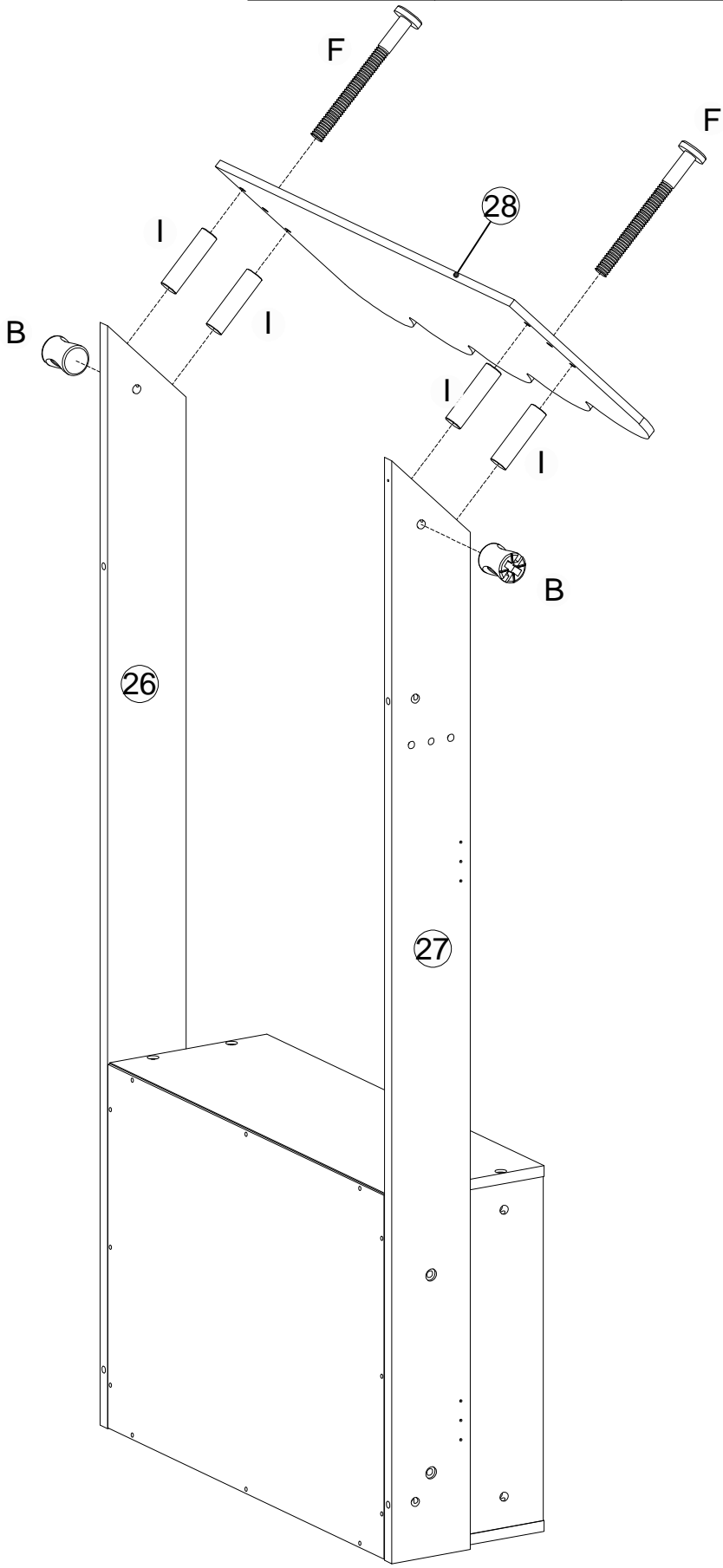
B  2 pcs/pièces	F  2 pcs/pièces	C  1 pc/pièce	I  4 pcs/pièces
---	--	---	---



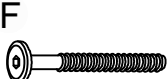

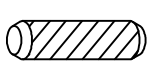
Step/Étape 16

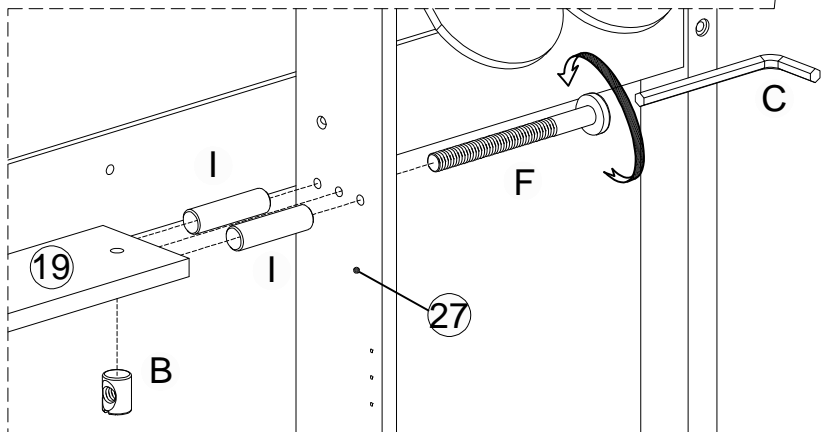
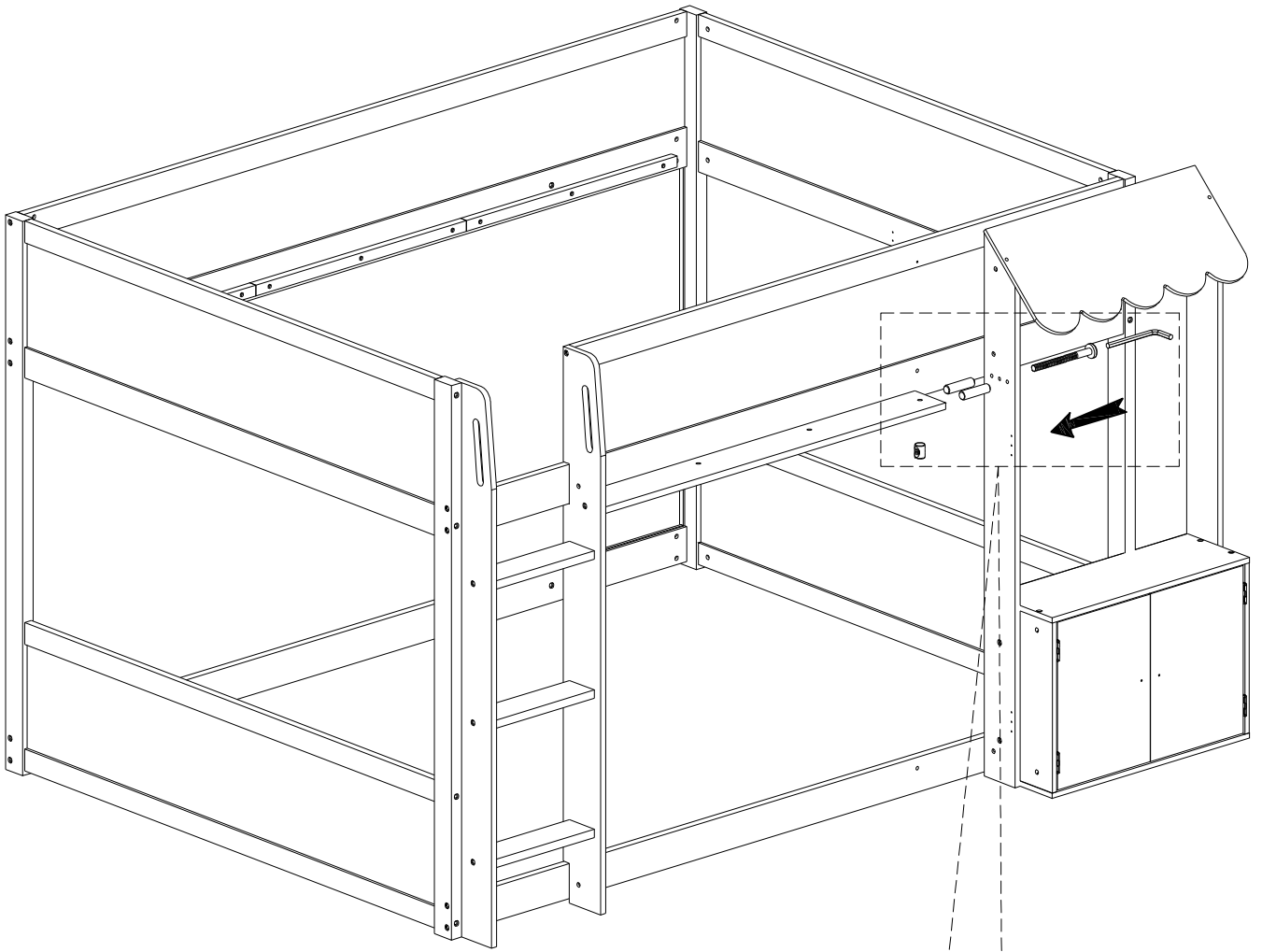
B  1 pc/pièce	F  1pc/pièce	C  1 pc/pièce
I  2 pcs/pièces		

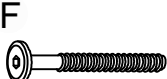

Step/Étape 17

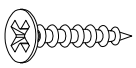
B  4 pcs/pièces	F  4 pcs/pièces	C  1 pc/pièce
S  1 pc/pièce		

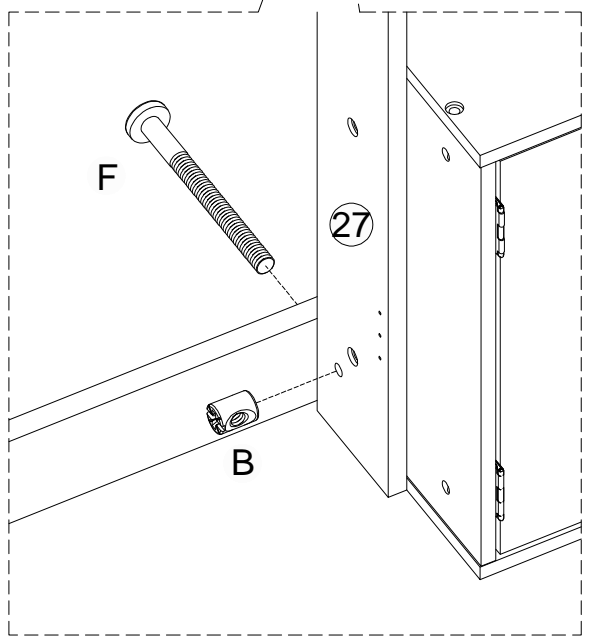
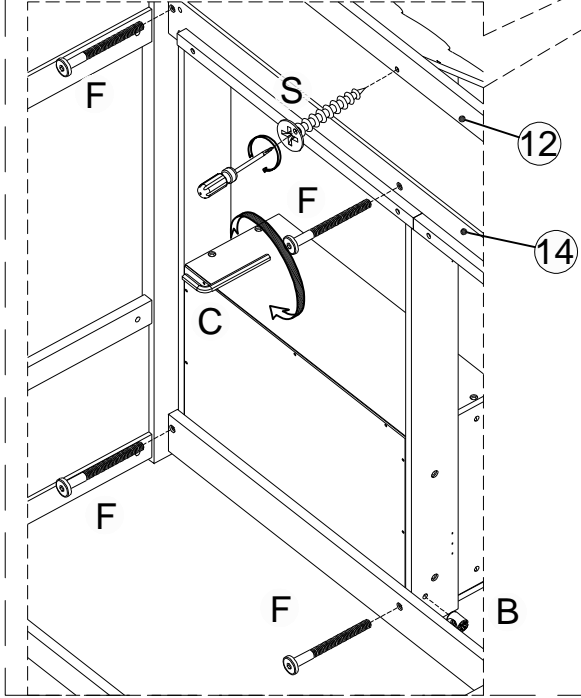
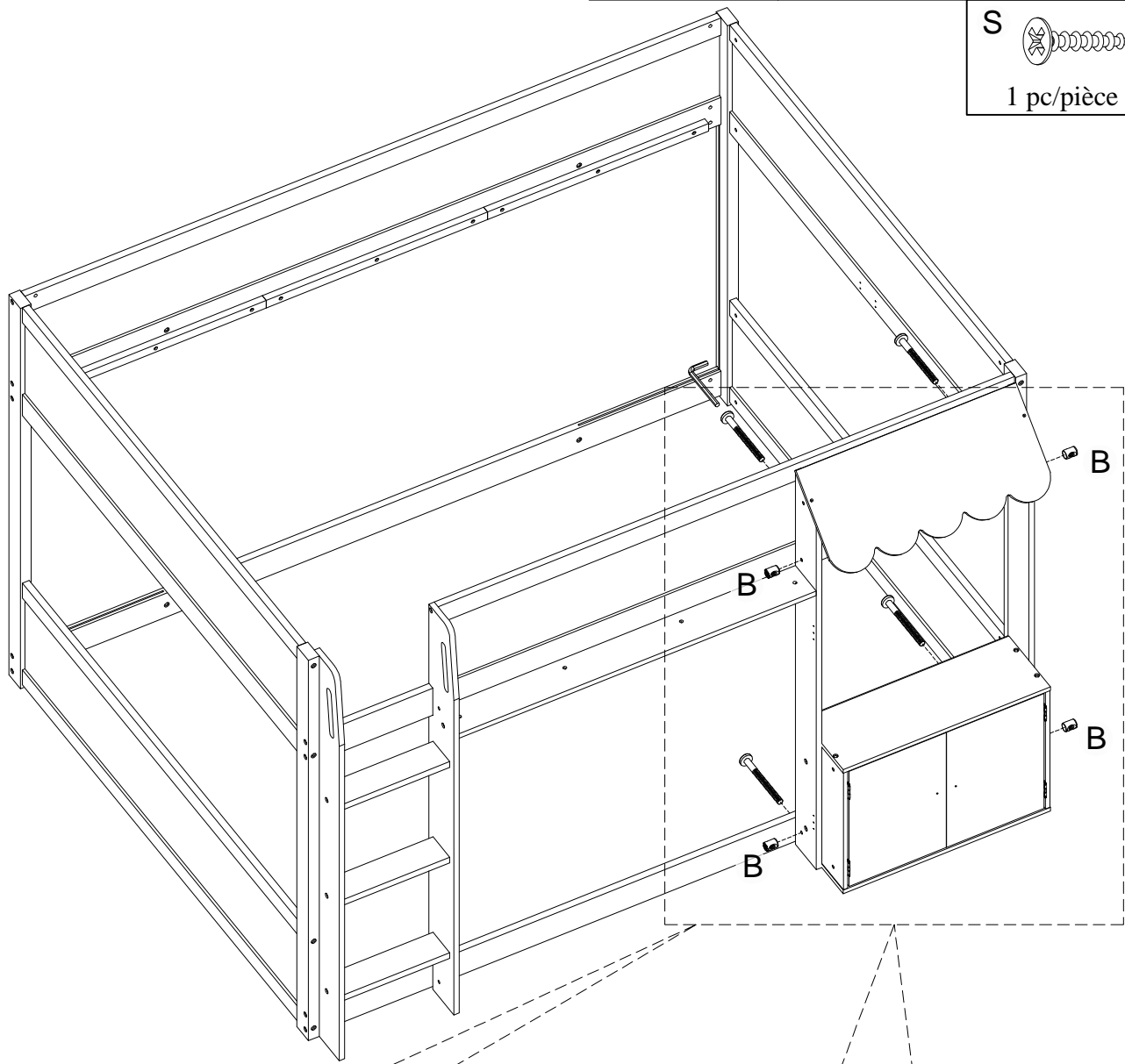

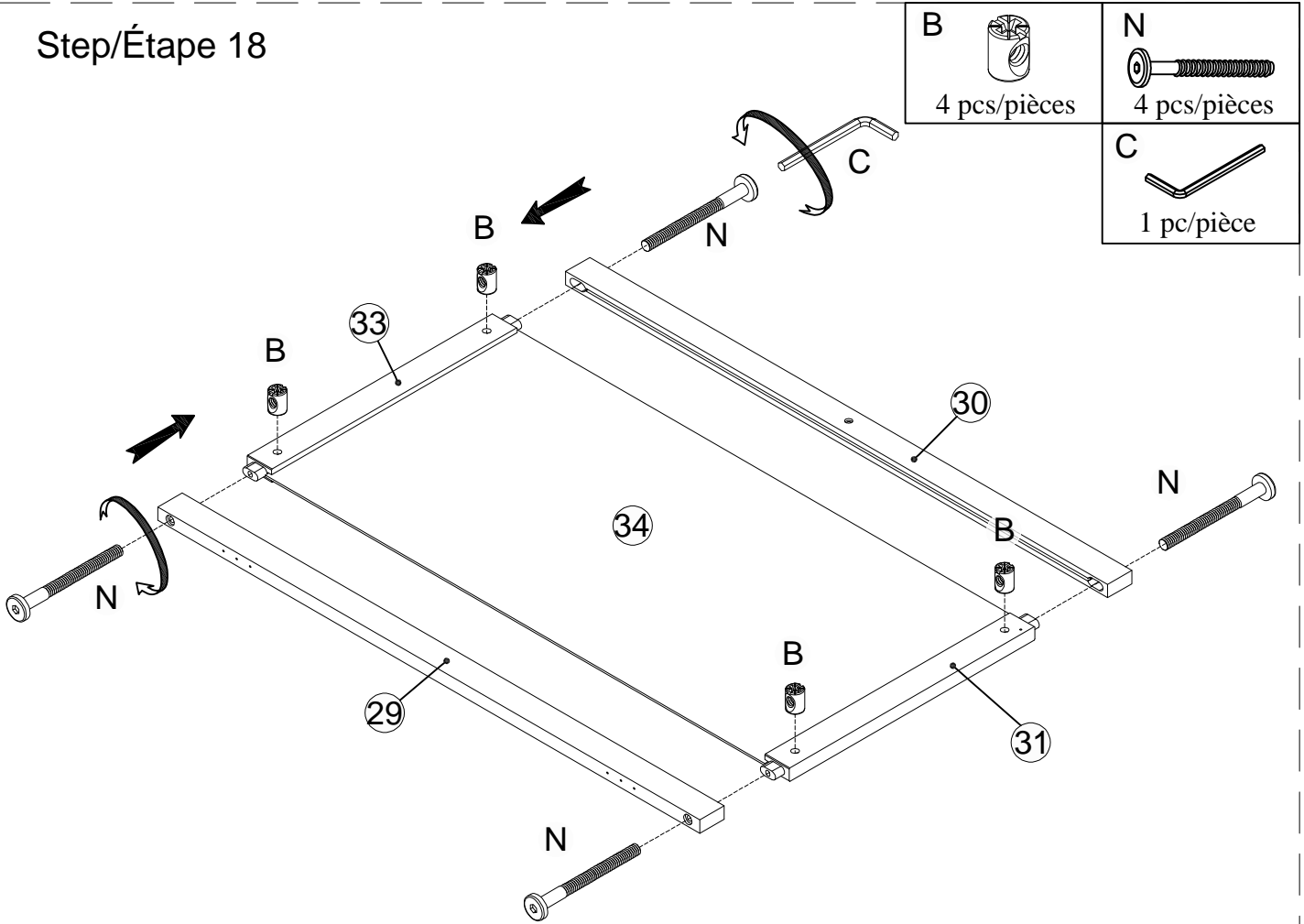

Step/Étape 18

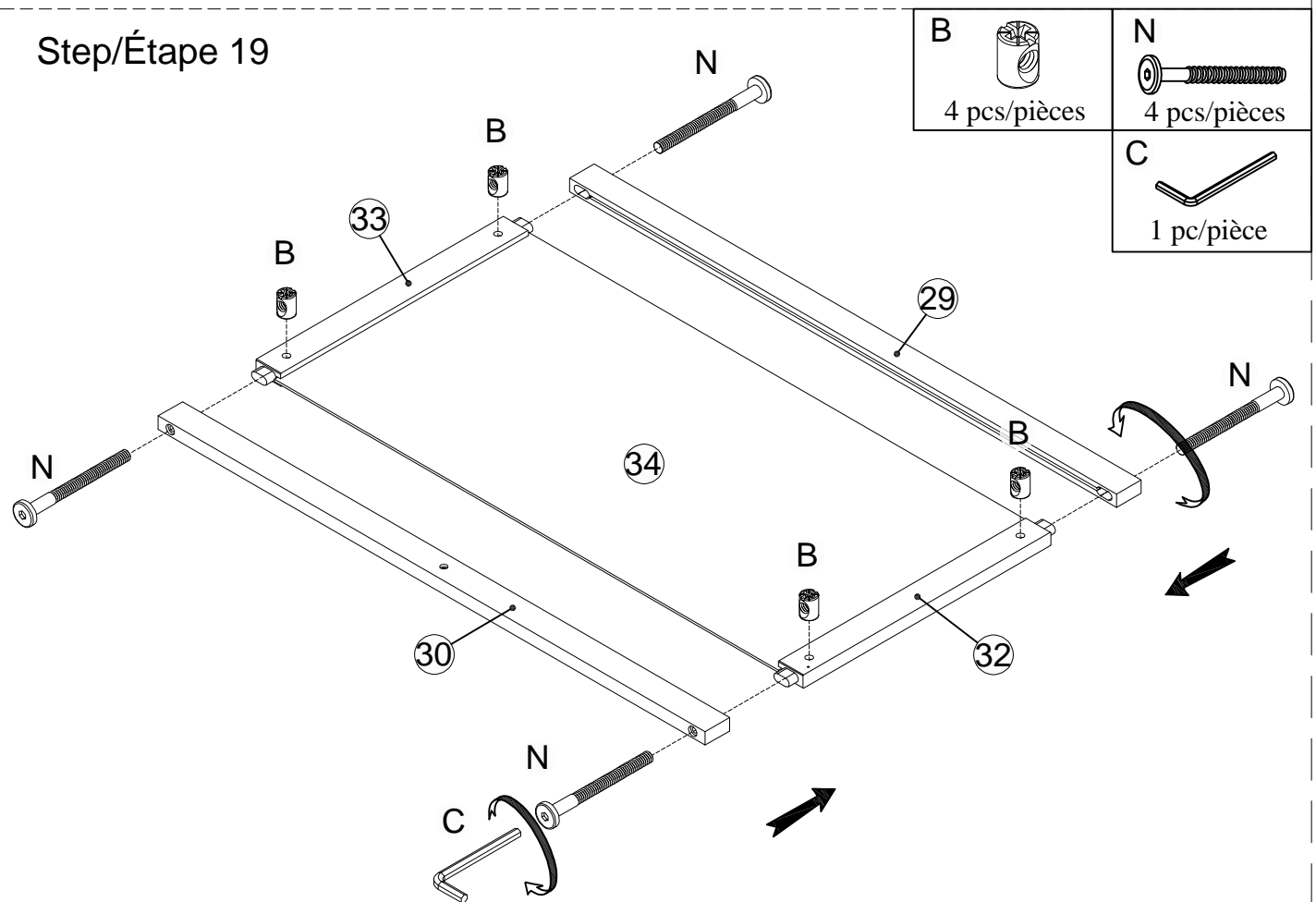

Step/Étape 19

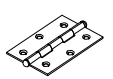

Step/Étape 20

<p>H1</p>  <p>2 pcs/pièces</p>	<p>G</p>  <p>16 pcs/pièces</p>
<p>O</p>  <p>4 pcs/pièces</p>	

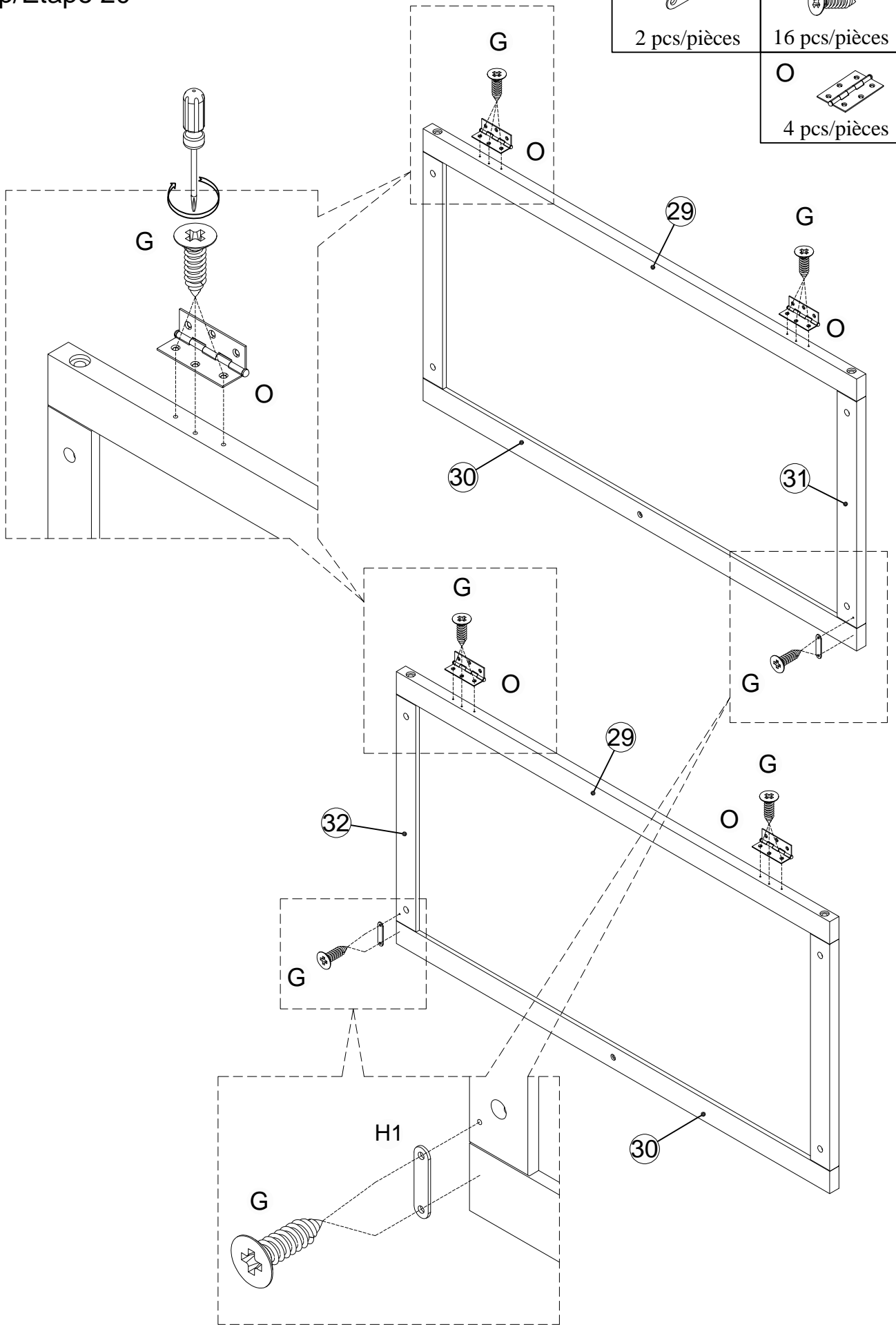

Step/Étape 21

G
12 pcs/pièces

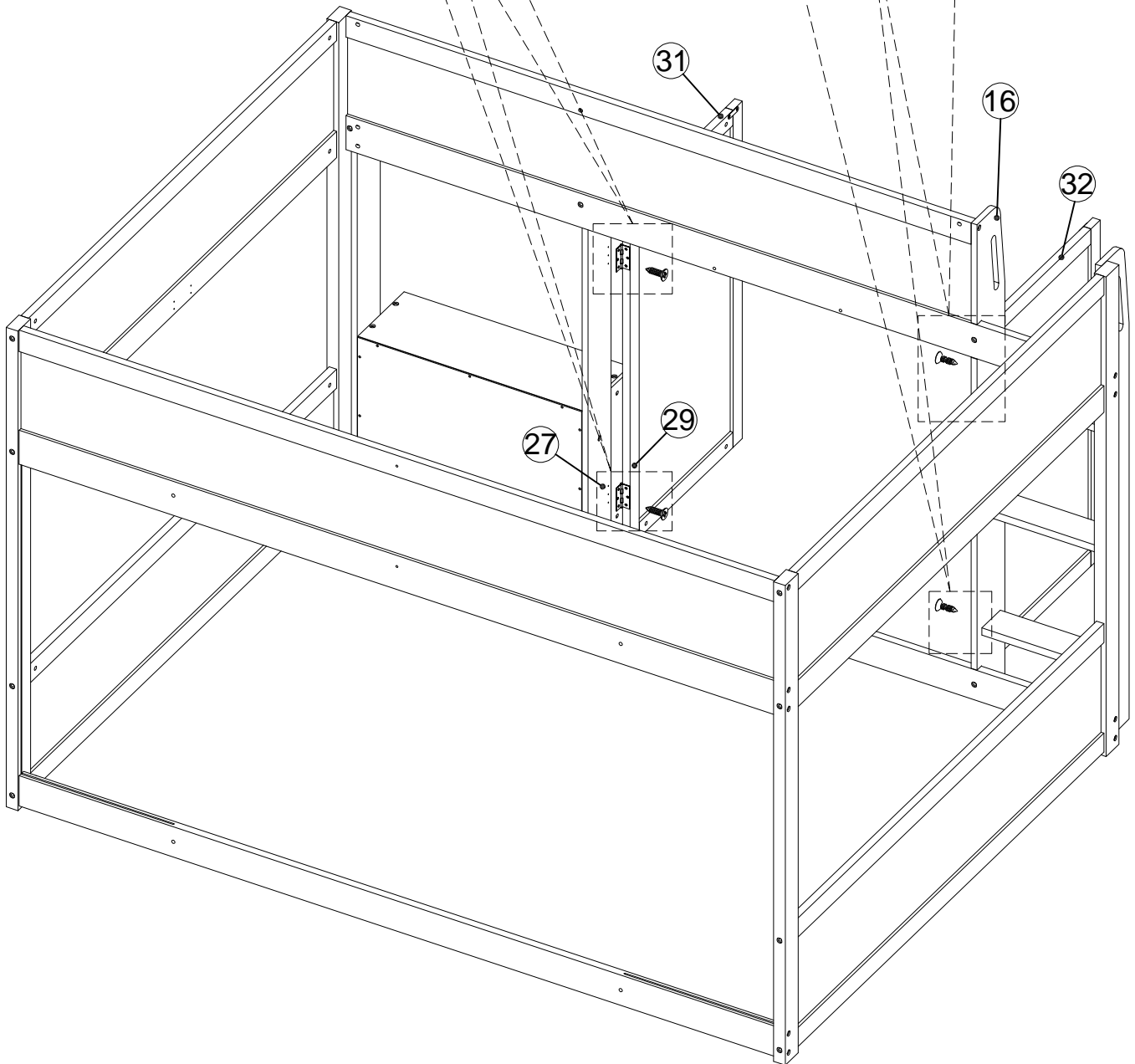
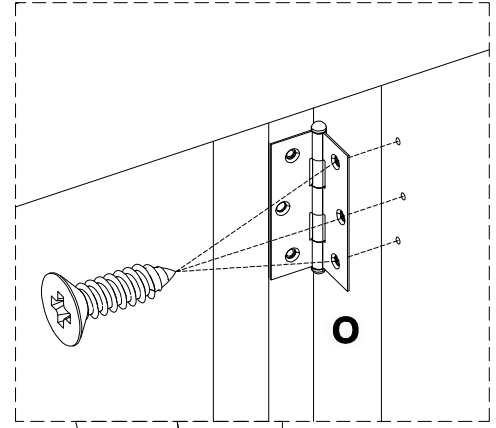
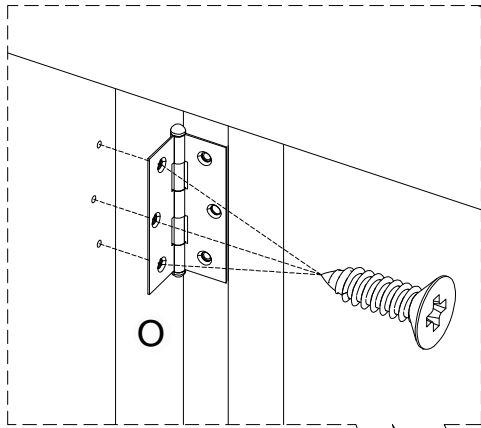

Step/Étape 22

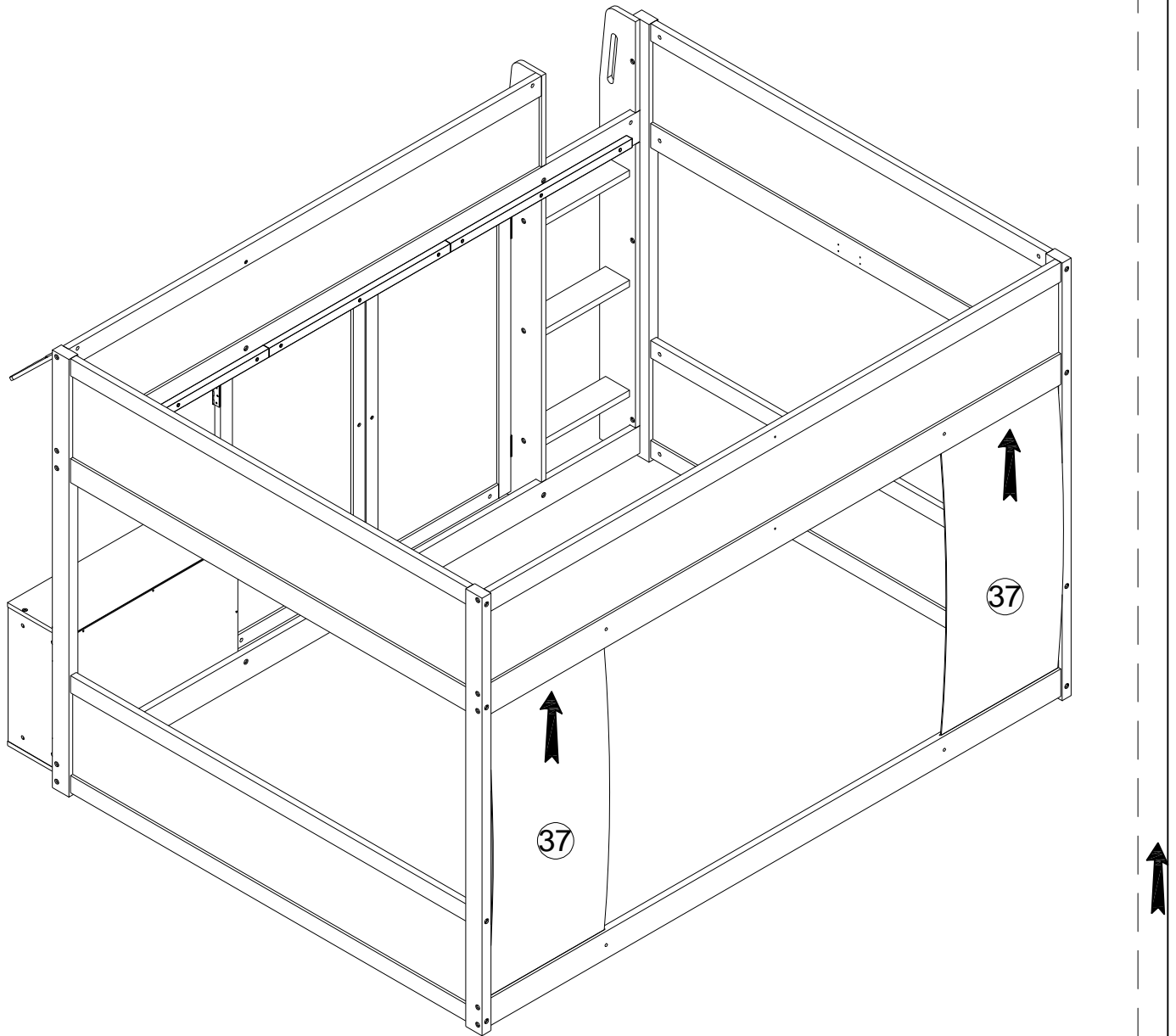

Note : Insert one end of the back panel into the bed rail groove → Bend slightly
→ Fit into lower groove.

Note : Insérez une extrémité du panneau arrière dans la rainure du longeron
→ Pliez légèrement → Engagez dans la rainure inférieure.

Step/Étape 23

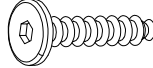
J  2 pcs/pièces

P  4 pcs/pièces

L  4 pcs/pièces

C  2 pcs/pièce

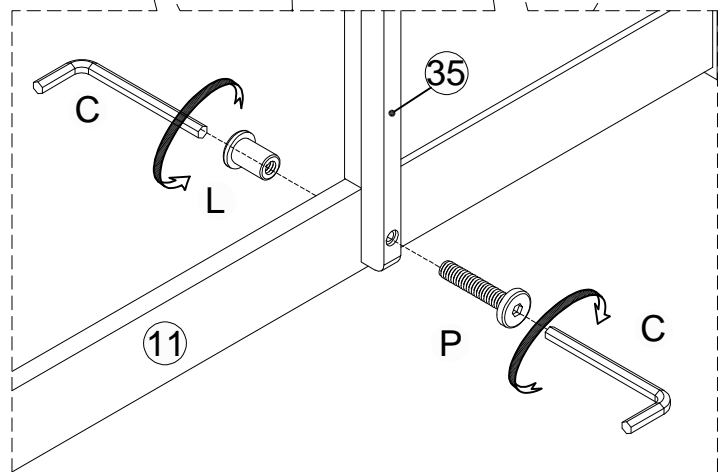
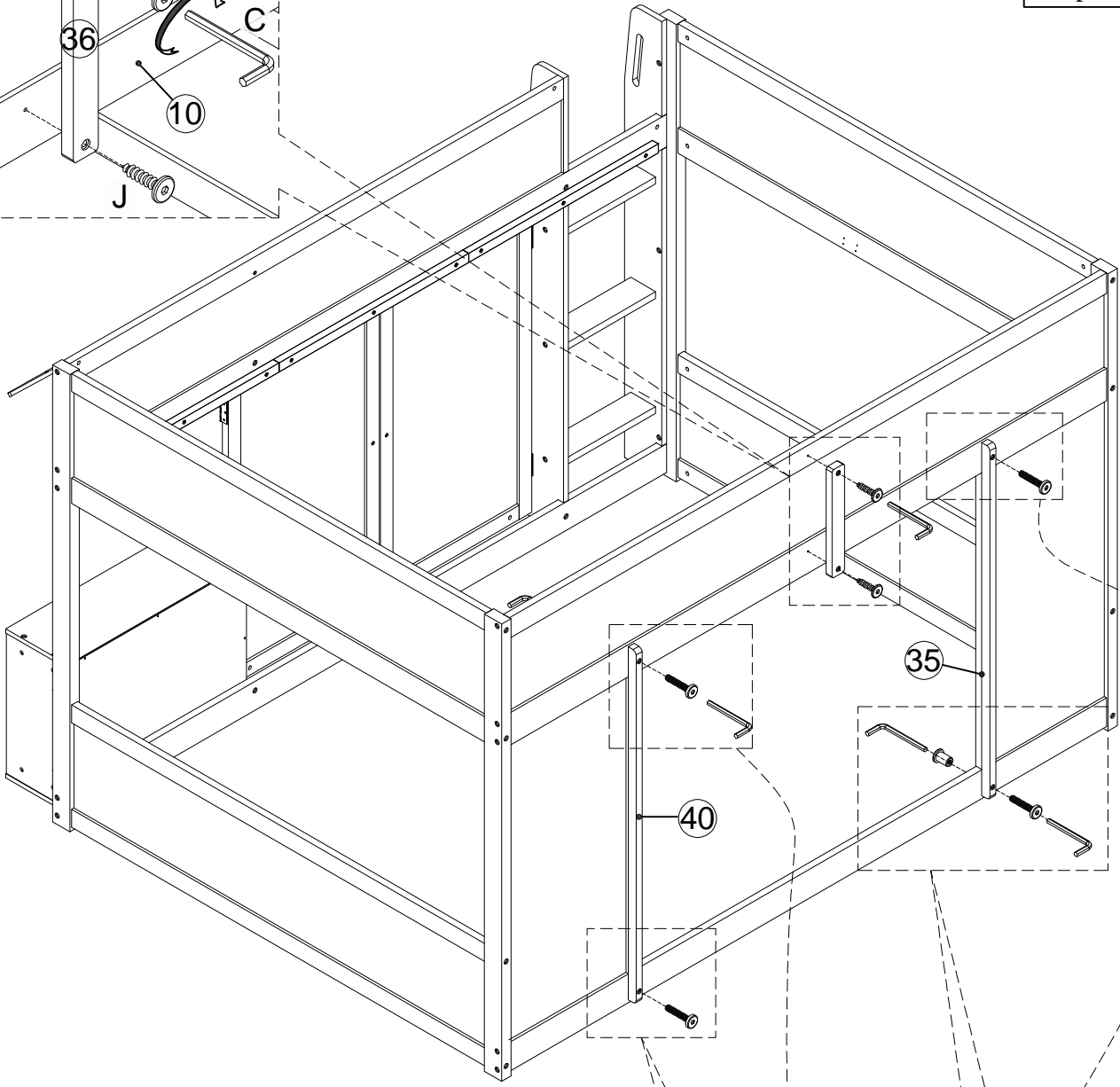
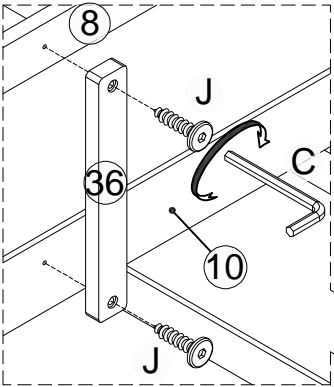

Step/Étape 24

Q



8 pcs/pièces

R

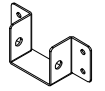

2 pcs/pièces

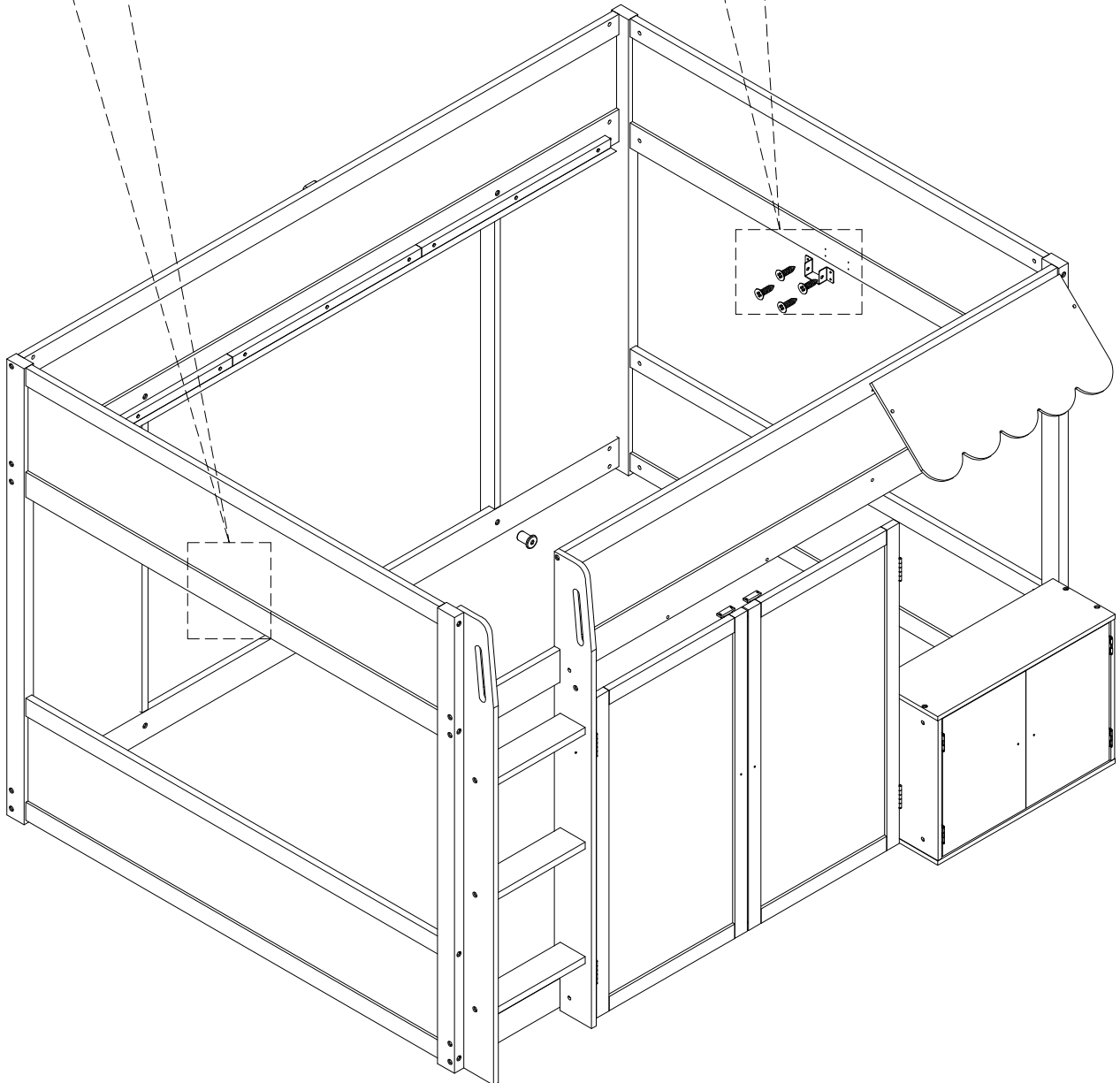
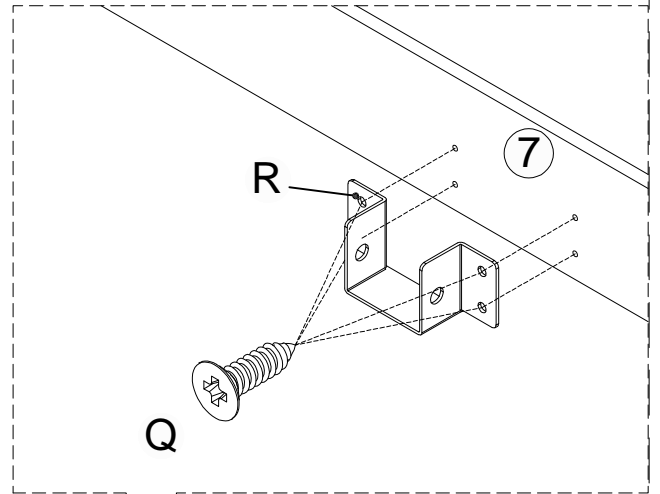
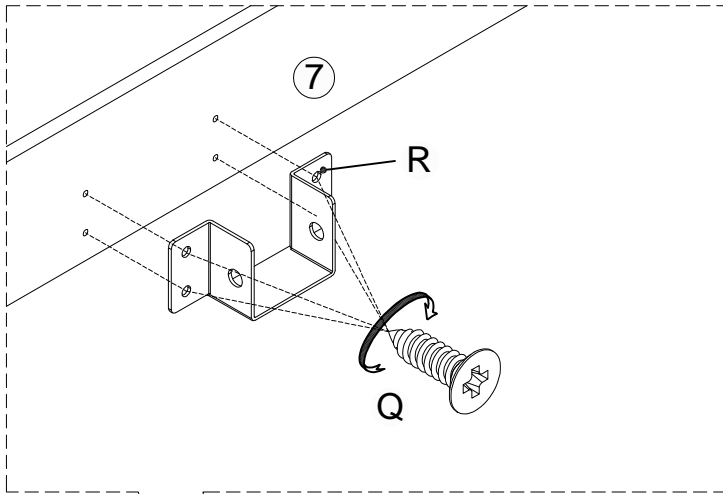

Step/Étape 25

Q 
4 pcs/pièces

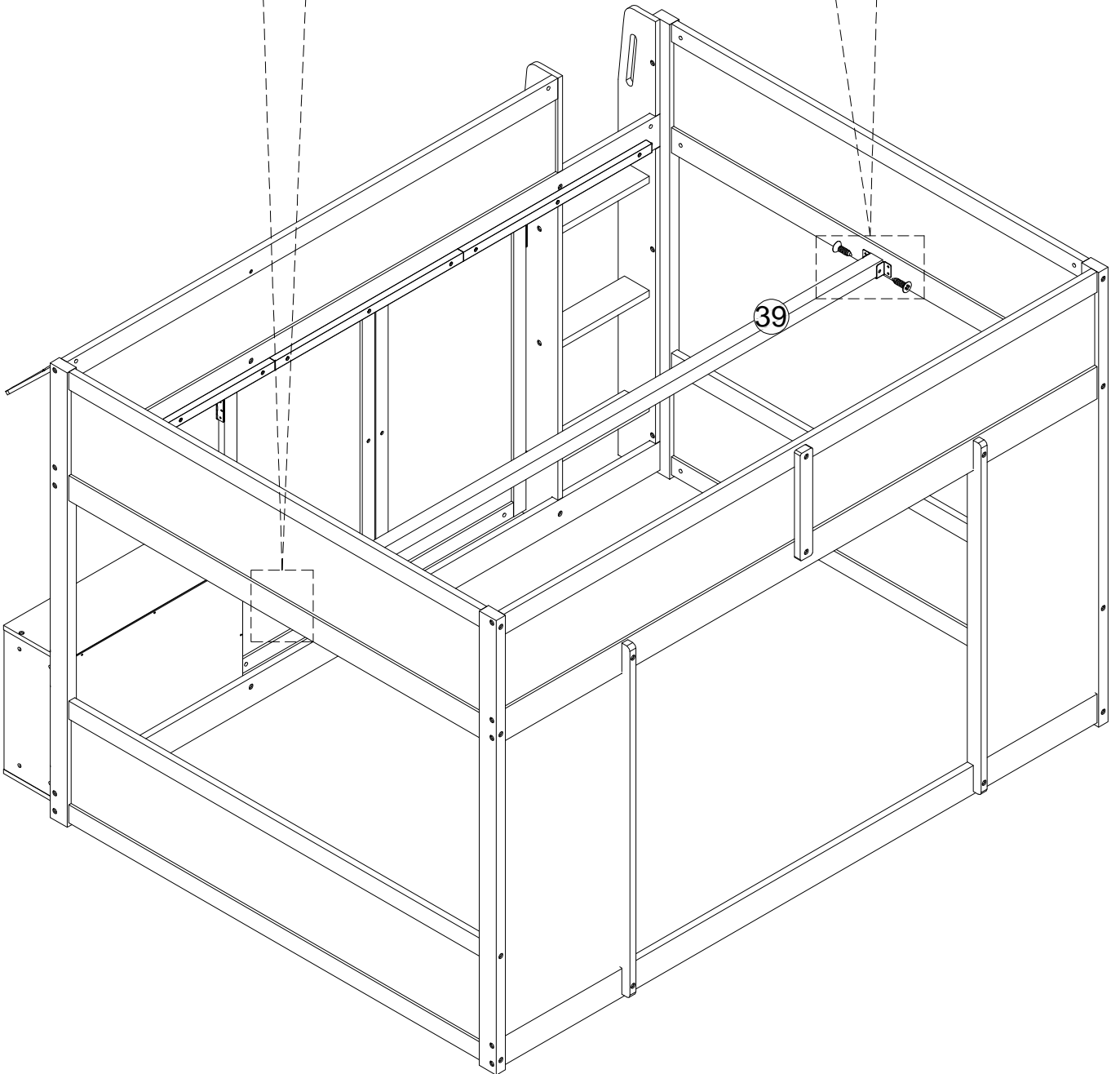
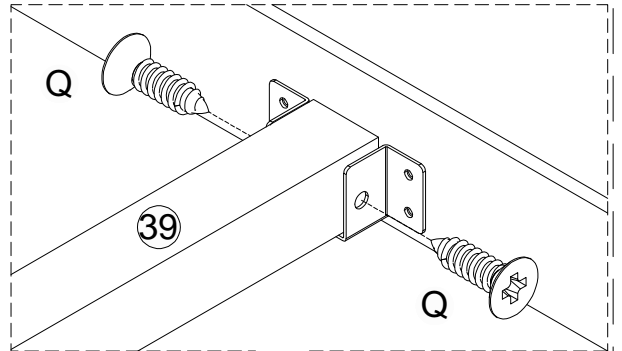
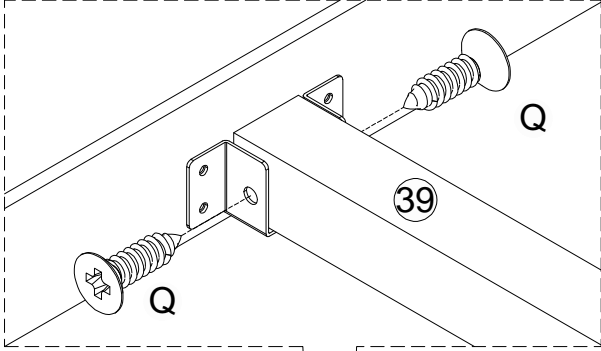

Step/Étape 26

S 
42 pcs/pièces

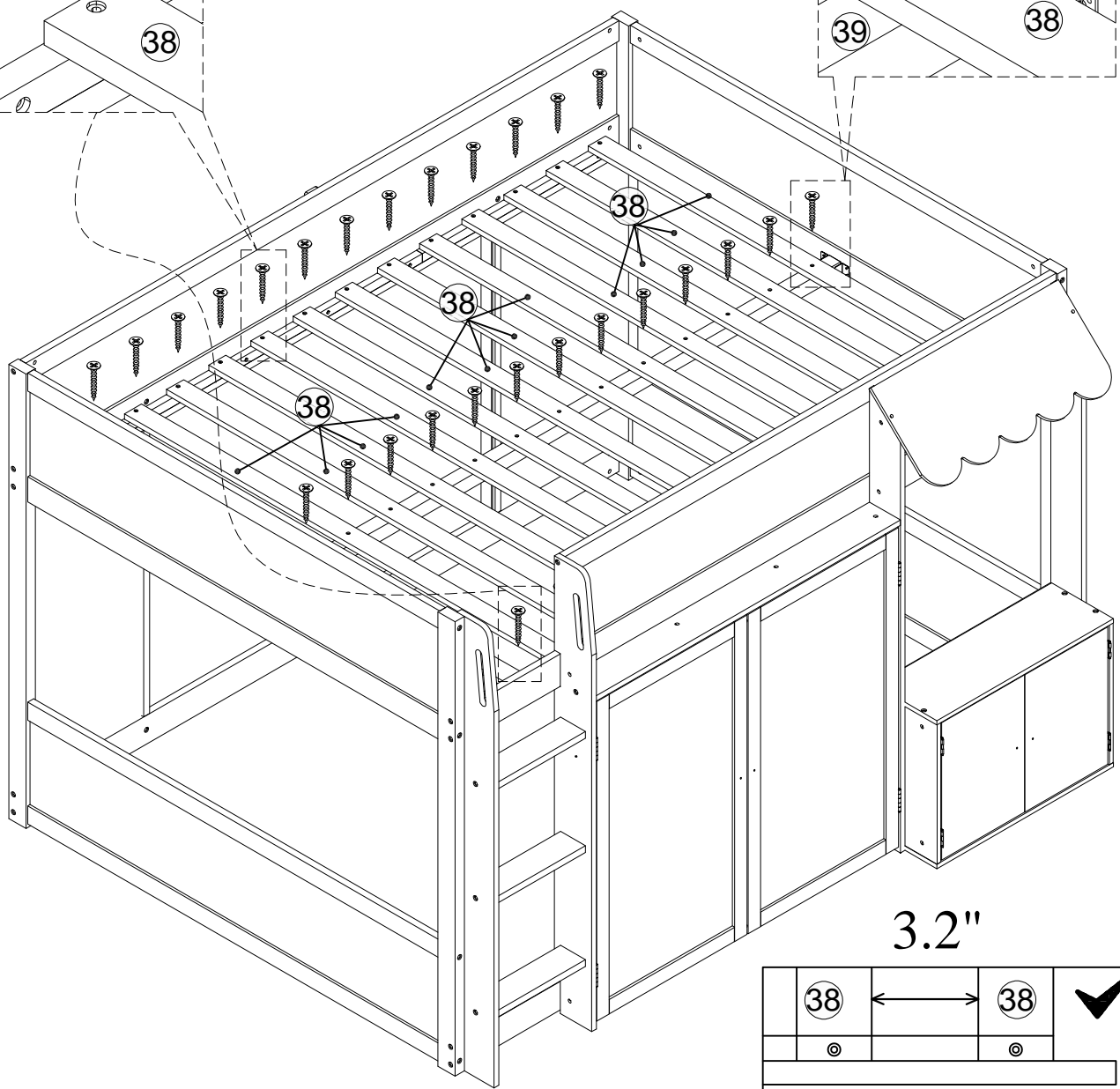
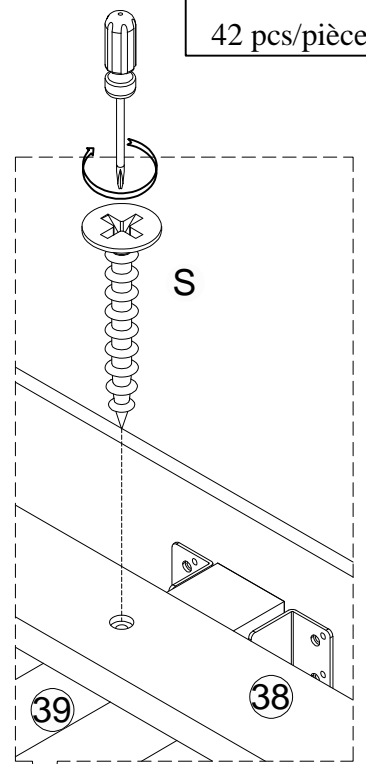
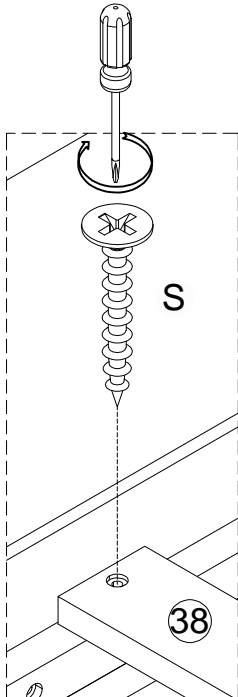

3.2"

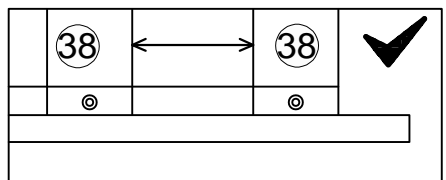

Step/Étape 27

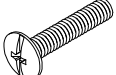
Y		Z	
	2 pcs/pièces		2 pcs/pièces

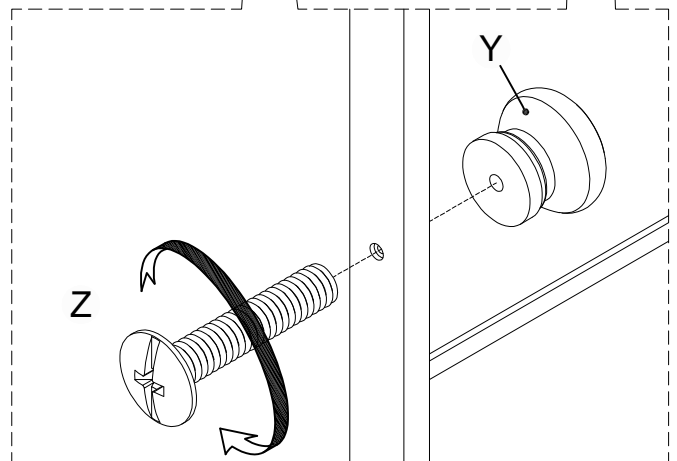
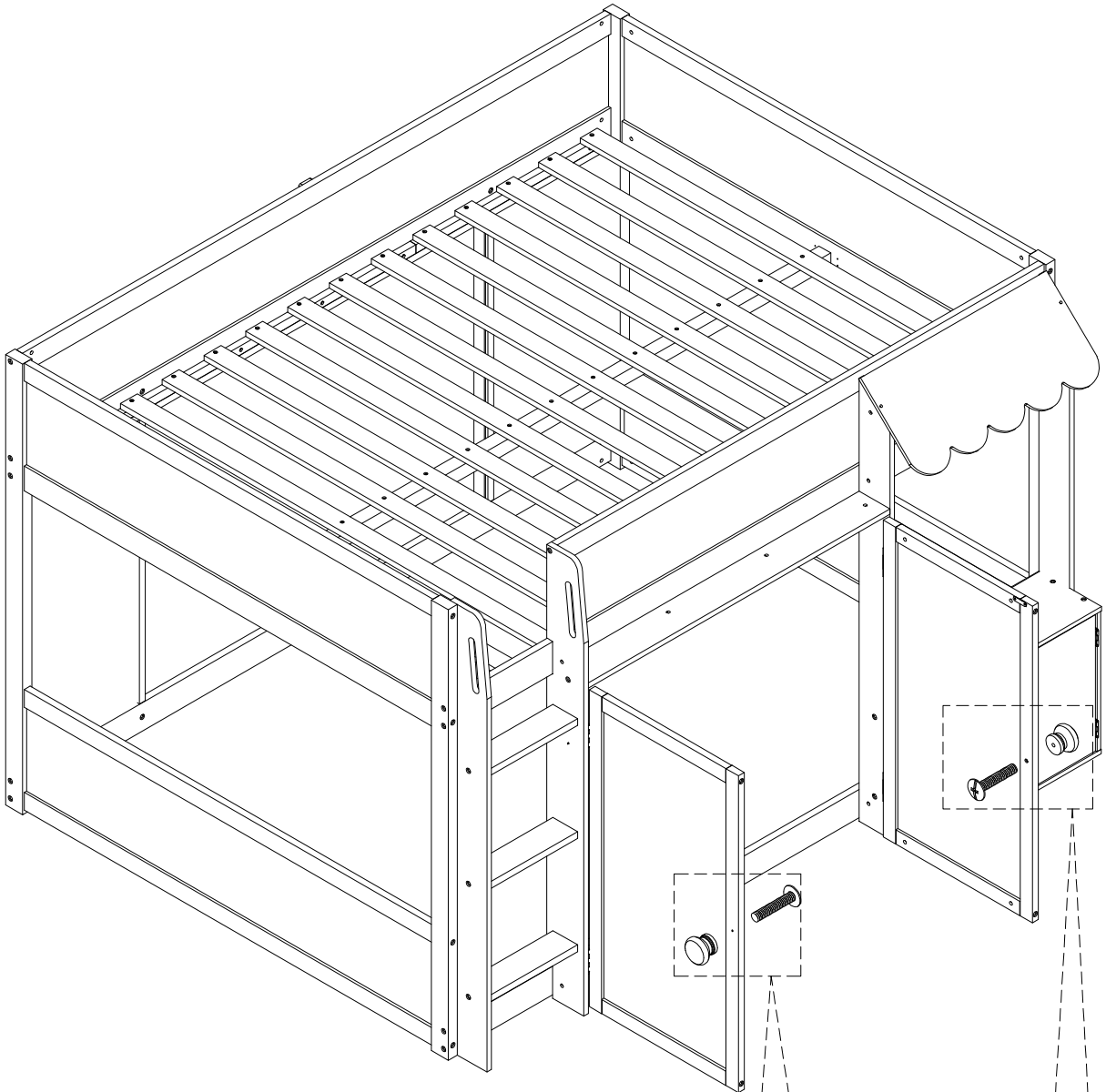

Step/Étape 28

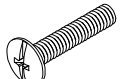
Y		Z	
	2 pcs/pièces		2 pcs/pièces

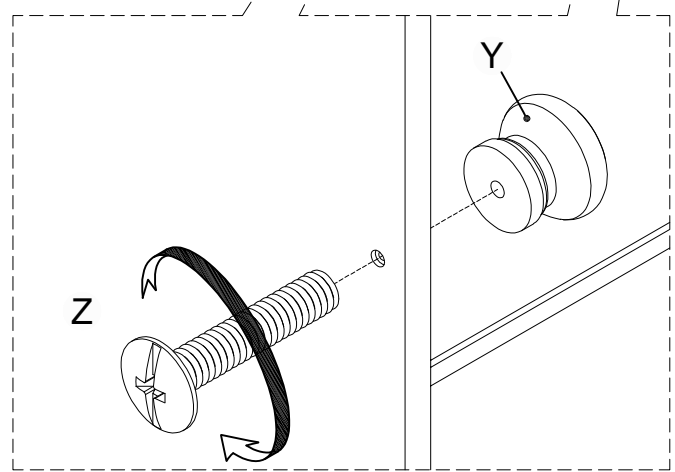
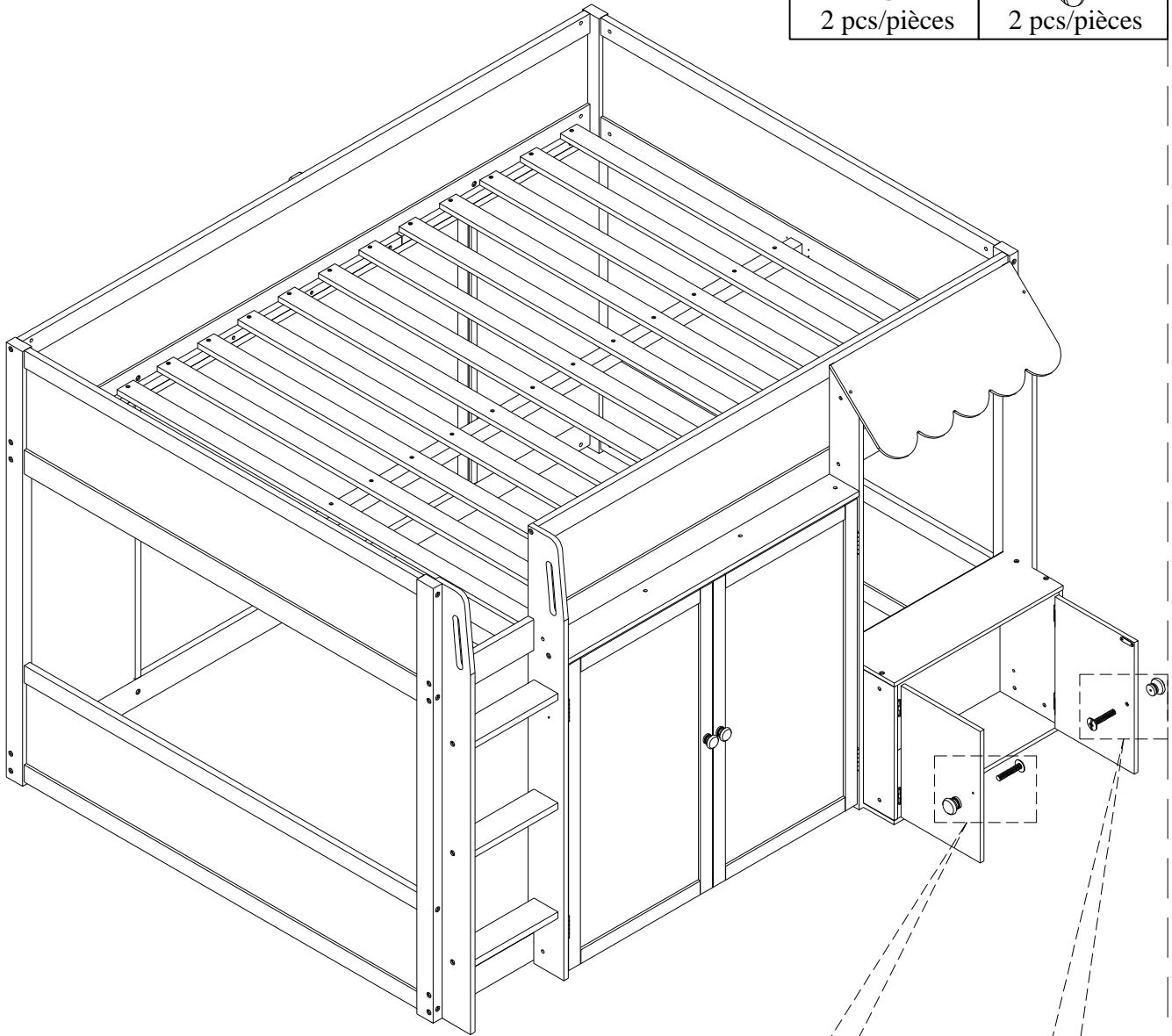

COMPLETED - COMPLÉTÉ

