

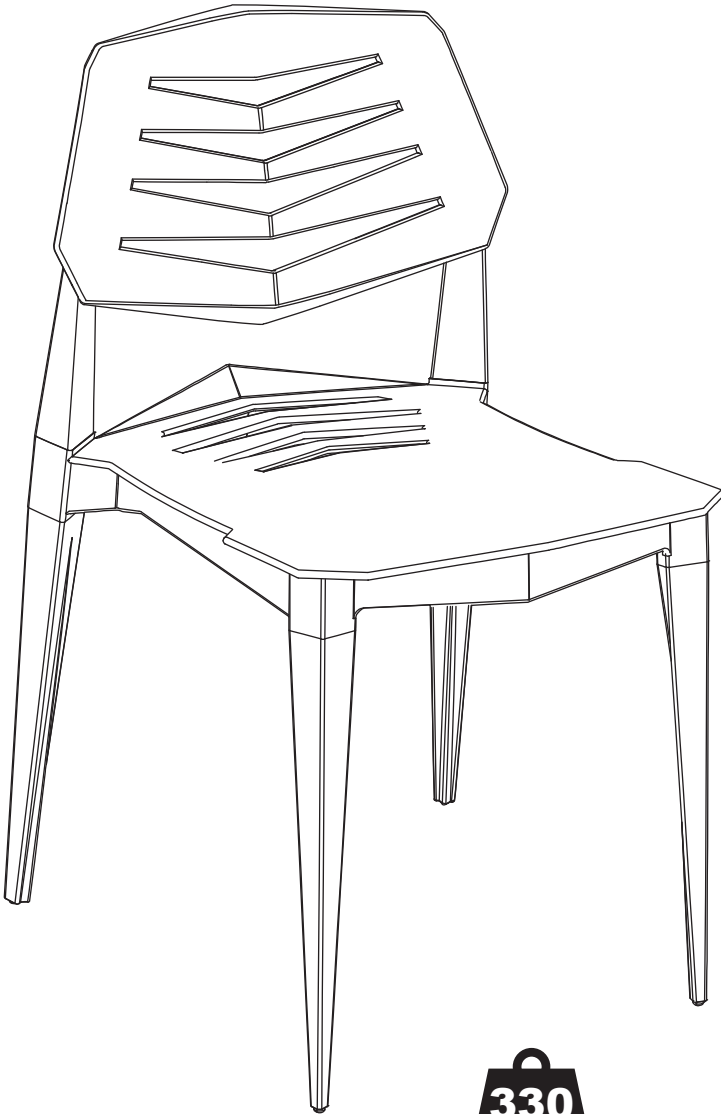

POLYPROPYLENE CHAIR

Review all assembly and care information before using this product. Save this manual for future reference.
Assemble components on a soft, clean surface to avoid damaging the finish.

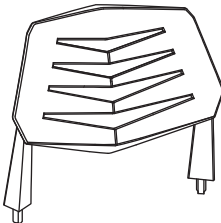
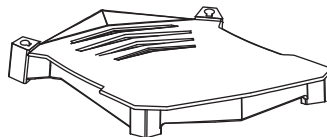

Inspect packaging to ensure all parts are accounted for before disposing of packing materials.
 Save the packing slip.

No.	PARTS	QTY.
A	 Backrest	1
B	 Seat	1
C	 Front Leg with 2 Screws	2
D	 Back Leg with 1 Screw	2

NOTE: Quantities shown are for one chair.

IMPORTANT: The front and back leg screws are different lengths; ensure each leg is secured using the exact screw(s) that are loosely fastened to it.

INCLUDED TOOLS



Hex Key

RECOMMENDED TOOLS (not included)

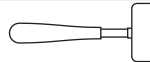

Rubber Mallet

! WARNING !

CHOKING HAZARD — This item contains small parts that can be swallowed. Keep children and pets away during assembly.

330
pounds
 150 kg
 Weight Capacity

! WARNING:

Manufacturer and seller expressly disclaim any and all liability from personal injury, property damage or loss, whether direct or indirect, or incidental, resulting from the incorrect attachment, improper use, inadequate maintenance, or neglect of this product.

ASSEMBLY

STEP 1

B: 1

C: 2

D: 2

NOTE: Screw(s) are loosely fastened to each leg. Remove the screw(s) before installing each leg on the seat.

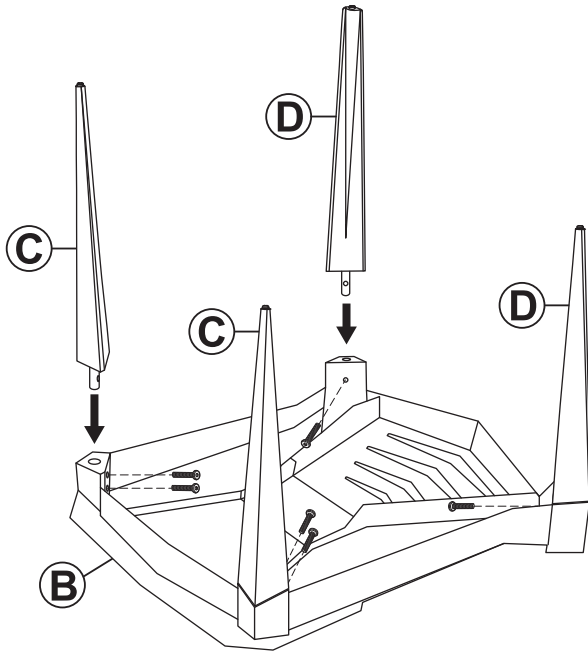

Lay Seat (B) face-down on a soft, clean surface.

Affix two Front Legs (C) to the front of the seat using the included screws.

Then, affix two Back Legs (D) to the back of the seat using the included screw.

STEP 2

A: 1

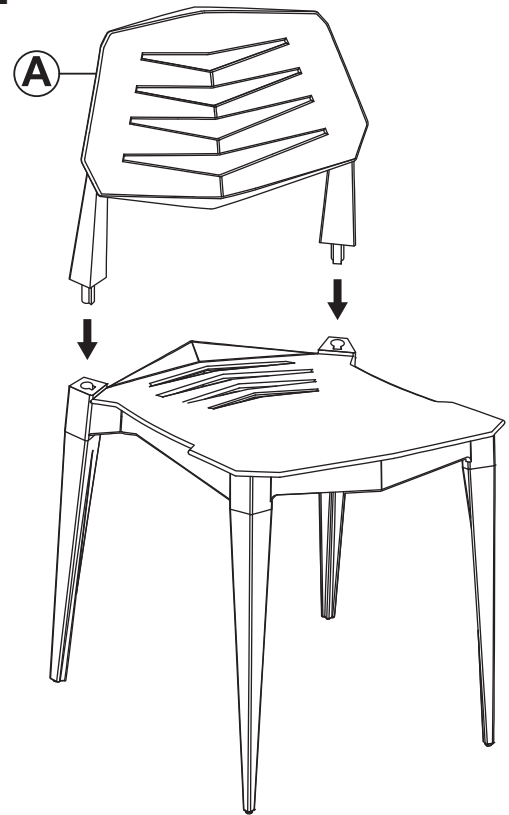

Turn the unit upright.

Align Backrest (A) with the back of the seat and firmly push the backrest into the designated holes.

CARE & MAINTENANCE

SAFE USE: Never stand on the chair. Do not exceed the weight capacity. Only use on a flat, level surface. Keep this item a safe distance away from heat sources such as fire pits, patio heater, and grills. For residential use only, commercial or industrial use will automatically void the product warranty.

INSPECT: Periodically check assembly points and tighten fittings as necessary.

COVER: When not in use, cover with a breathable cover to help protect the unit from dust build-up, collecting debris, and the effects of long-term sun exposure.

WINTER CARE & STORAGE: Protect this item from inclement weather, especially high winds, hail, ice and snow. Move unit to a dry, indoor location. Cover while in storage to help prevent dust build-up.

CLEANING

Do not use harsh chemicals or abrasive materials to clean this unit.

 **DO NOT USE BLEACH**

 **DO NOT USE A PRESSURE WASHER**

Remove loose dust and debris with a soft, dry cloth.

Mix mild soap with warm water and wash the unit using a soft cloth.

Thoroughly rinse away all soap residue with clean water.

To prevent water spots, dry with a soft, lint-free cloth.

SAFETY STATEMENTS & WARNINGS

- Do not exceed the weight capacity.
- Never stand on the chair.
- Inspect hardware often, tighten loose hardware before use.
- Do not put hot items on or near furniture.
- Keep furniture a safe distance from heat sources such as, but not limited to, fire pits, patio heaters, and grills.
- Do not allow children to use this product without adult supervision.
- Do not use harsh chemicals or abrasive materials to clean the furniture.
- Do not use a pressure washer to clean the furniture.

Any modification to the product or failure to follow recommended care will void the product warranty.

If you experience issues with assembly or the product was damaged during shipping, please contact our customer service team through one of the methods mentioned at the top of page 1.

Please have the item number and order information ready to expedite response time.

WARNING:

Manufacturer and seller expressly disclaim any and all liability from personal injury, property damage or loss, whether direct or indirect, or incidental, resulting from the incorrect attachment, improper use, inadequate maintenance, or neglect of this product.