



ASSEMBLY INSTRUCTION

ITEM NO.: AC300 / AC301 / AC302

HARDWARE LIST			
Item	Description	Drawing	Pcs
A	Bolt 1/4*25		4
B	Spring washer 1/4"		4
C	Flat washer 1/4"		4
D	Allen key M4		1

PART LIST			
Item	Description	Drawing	Pcs
1	BACKREST FRAME		1
2	PILLOW		1
3	SWIVEL BASE		1

STEP : 1

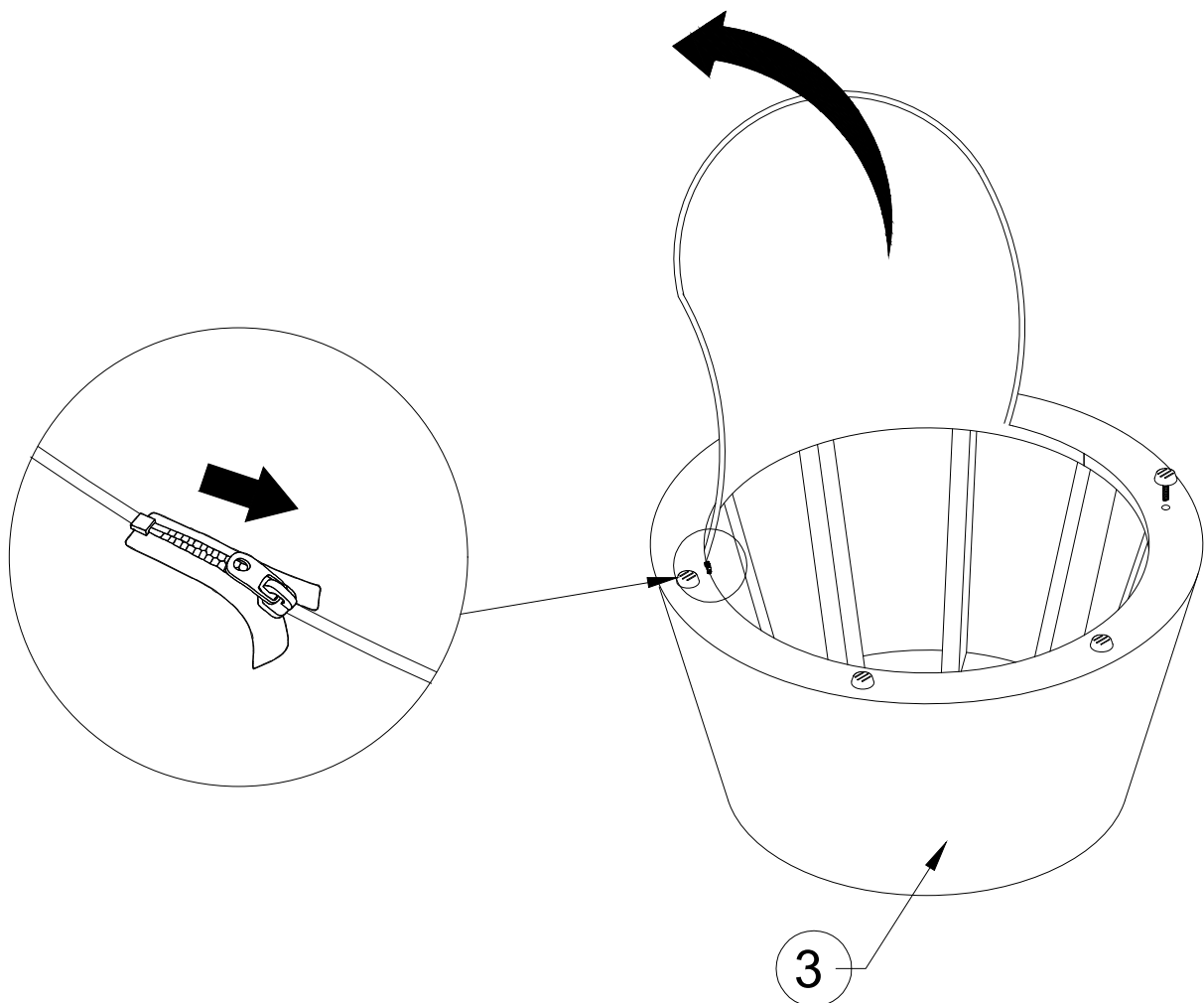

Do not tighten bolt until completely assembled

STEP : 2

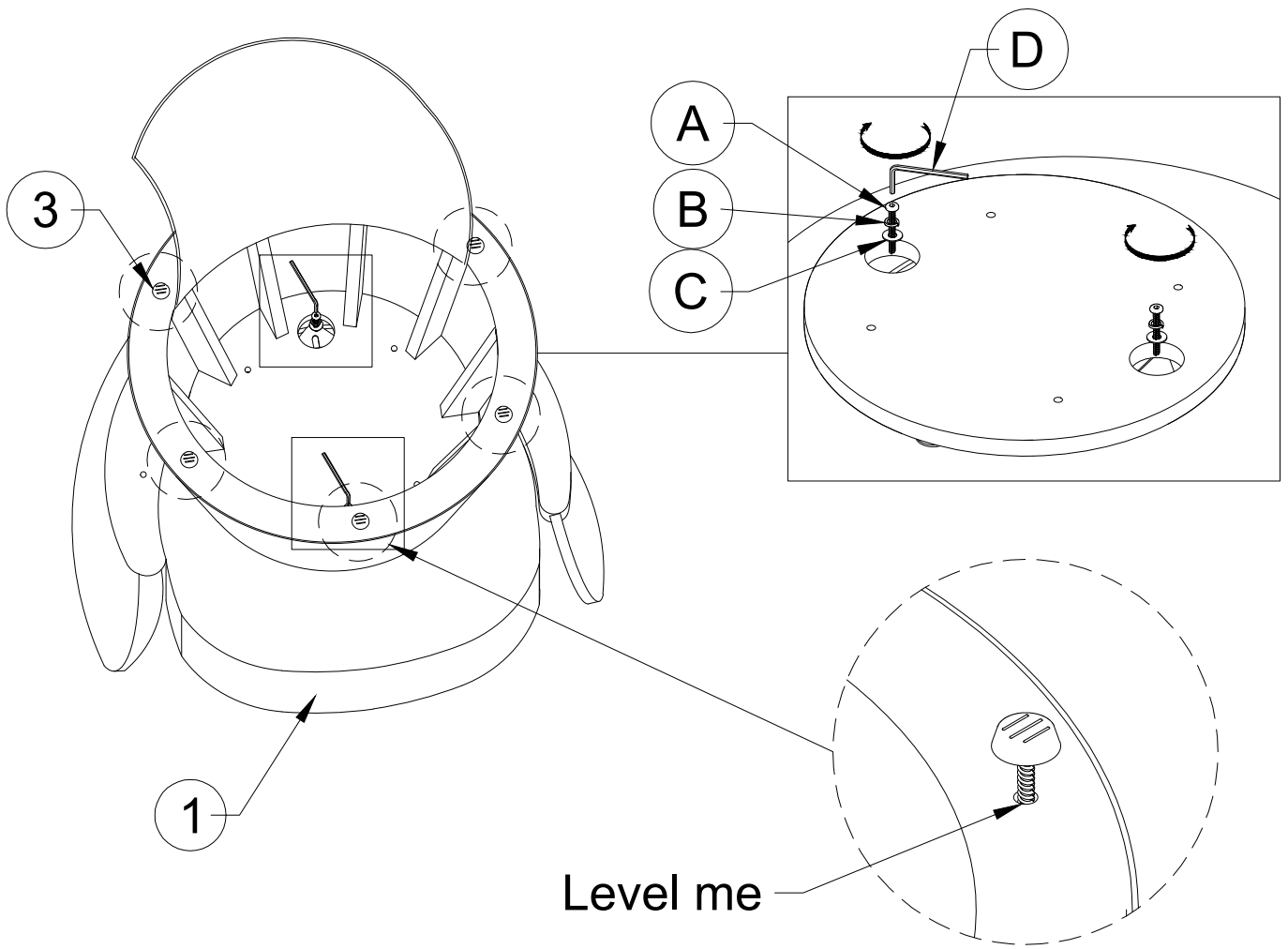

STEP : 3

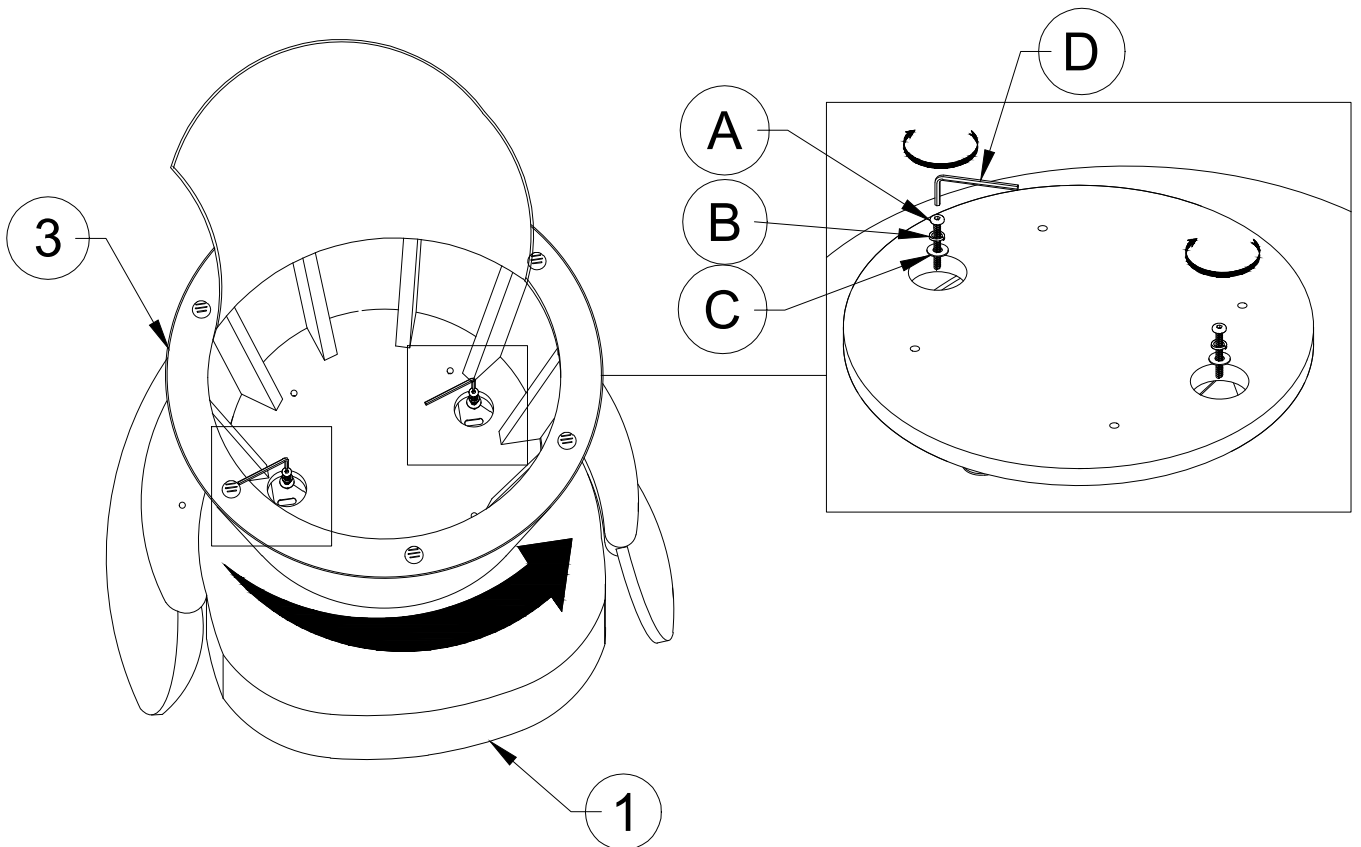

Do not tighten bolt until completely assembled

STEP : 4

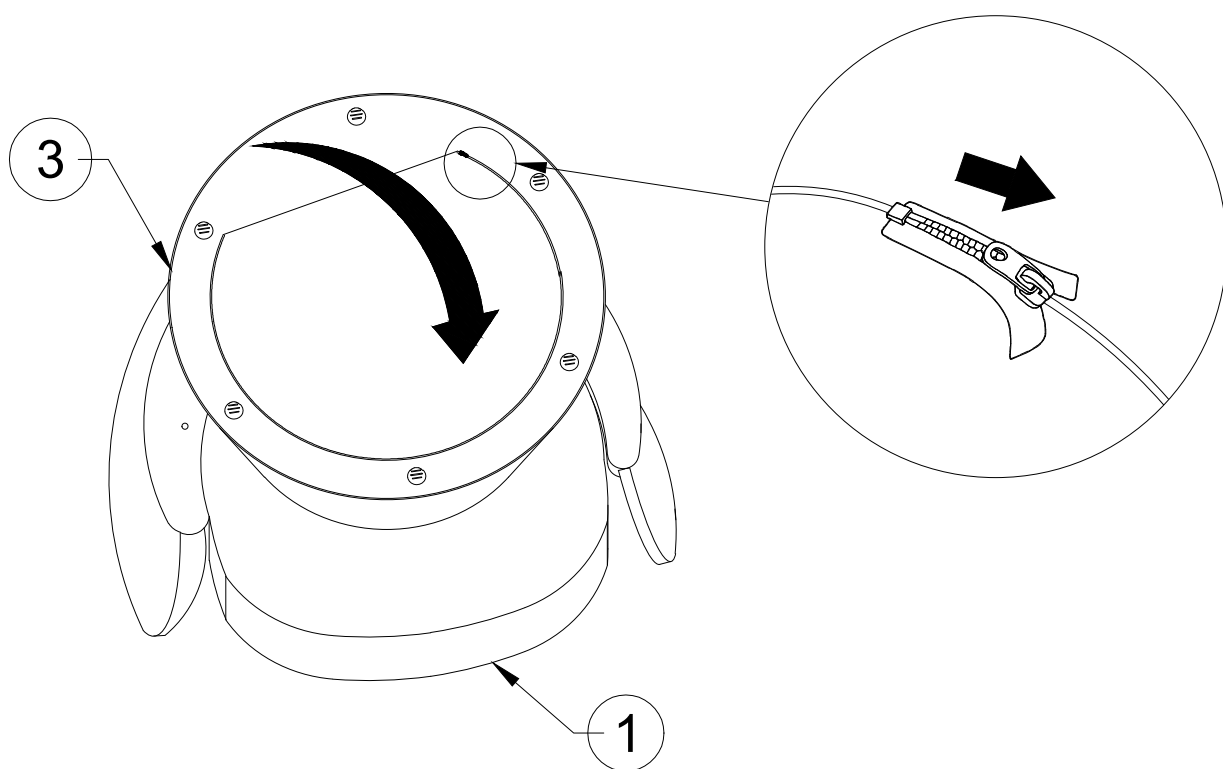

STEP : 5

COMPLETE

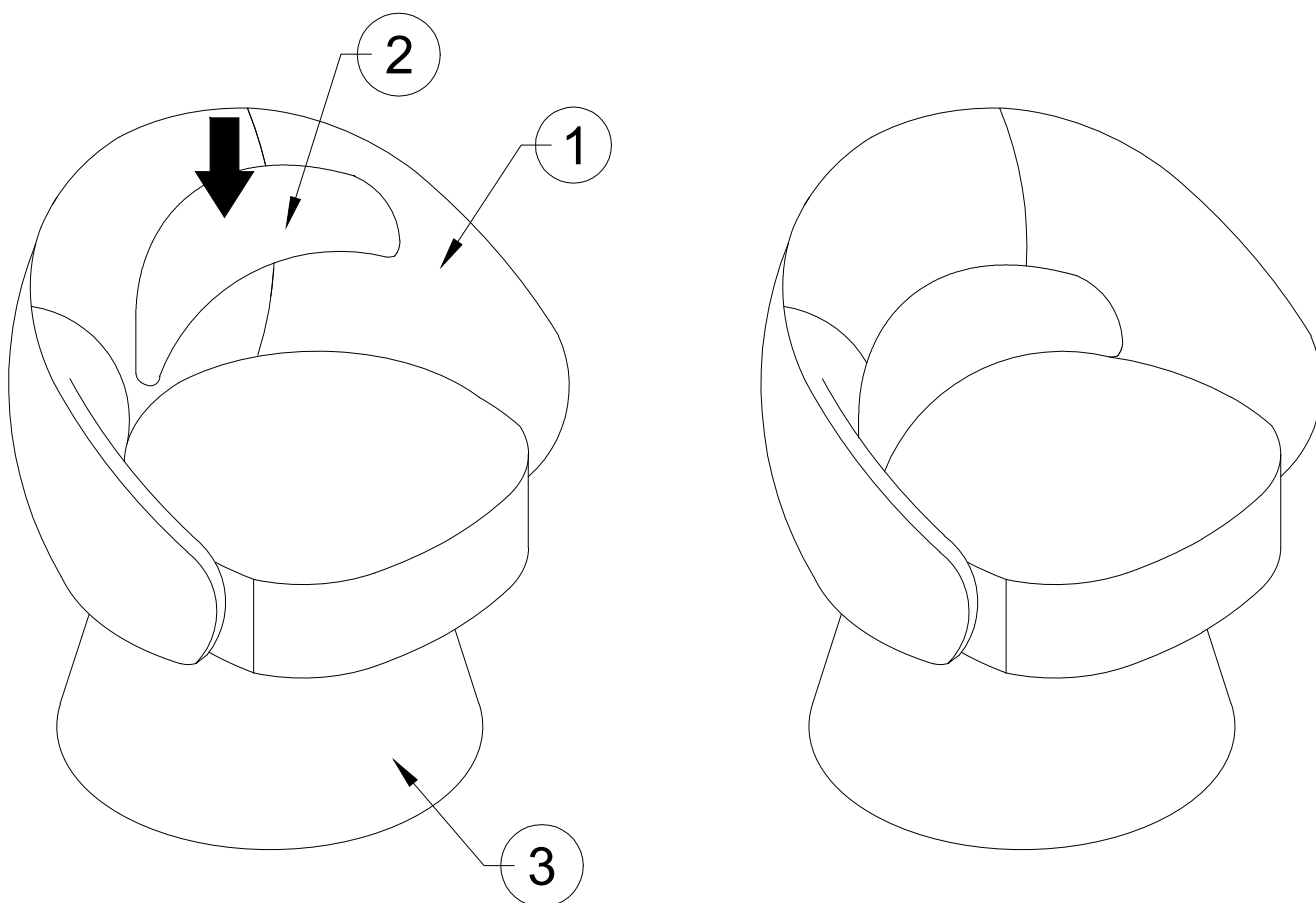

Do not tighten bolt until completely assembled