

THKFBV017

INSTALLATION INSTRUCTIONS

DIMENSIONS

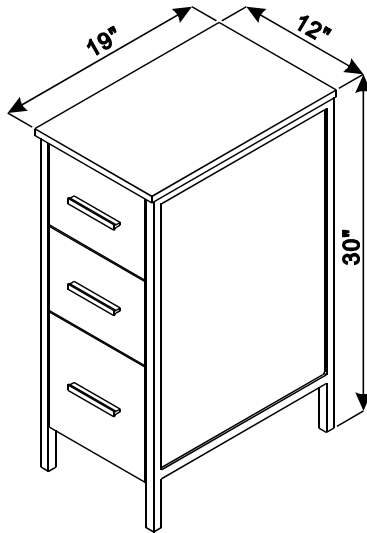





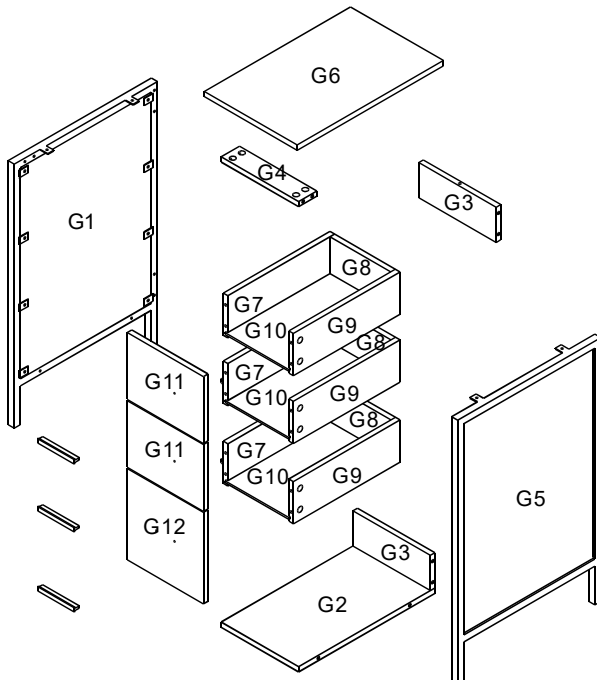









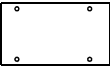

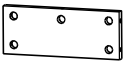

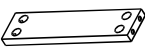

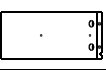

Unit:inch

ASSEMBLY DIAGRAM

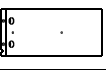

PARTS LIST

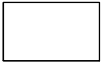
| PARTS LIST | | | HARDWARE LIST | | |
|------------|---|-----|---------------|---|-----|
| NO. | DESCRIPTION | QTY | NO. | DESCRIPTION | QTY |
| L |  | 1 | G11 |  | 2 |
| R |  | 1 | G12 |  | 1 |
| G1 |  | 1 | A |  CAM LOCK | 42 |
| G2 |  | 1 | B |  CAM SCREW B | 16 |
| G3 |  | 2 | C |  CAM SCREW C | 26 |
| G4 |  | 1 | D |  SCREW | 34 |
| G5 |  | 1 | E |  HASCREW | 6 |
| G6 |  | 1 | F |  HANDLE | 3 |
| G7 |  | 3 | G |  | 6 |
| G8 |  | 3 | H |  | 1 |
| G9 |  | 3 | J |  SCREW | 16 |
| G10 |  | 3 | | | |

CAUTION: Please confirm the parts list before installtion.

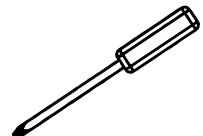

YOU MAY NEED (NOT SUPPLIED)



INSTALLATIONS

STEP 1

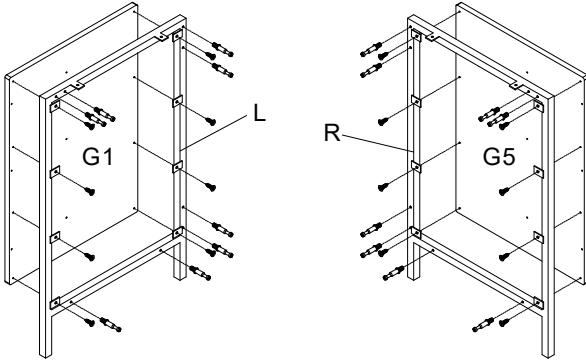

- Insert the cam screw into the shelves above.

| HARDWARE LIST | |  |
|---------------|---|---|
| B |  16PCS | |
| J |  16PCS | |



⚠ WARNING: Please make sure part B cam screws will be perpendicular to side panel, which will be convenient for installing part G2 G3 G4.

STEP 2

| HARDWARE LIST | |  |
|---------------|--|---|
| A |  1PCS | |
| C |  1PCS | |

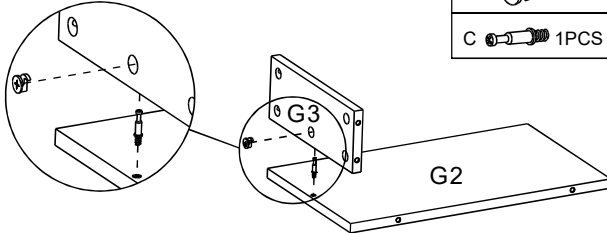

- Insert shelves G2 and G3 downwards to their corresponding positions, then tighten the cam lock.

STEP 3

| HARDWARE LIST | |
|---------------|--|
| G |  6PCS |

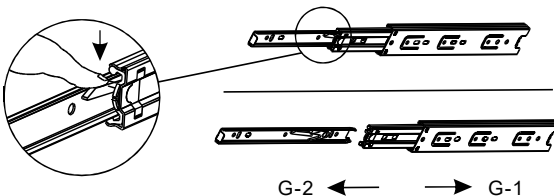

- Press the button and extend the slide slowly. Then separate it with the release latch. Repeat these steps for the other slides.

STEP 4

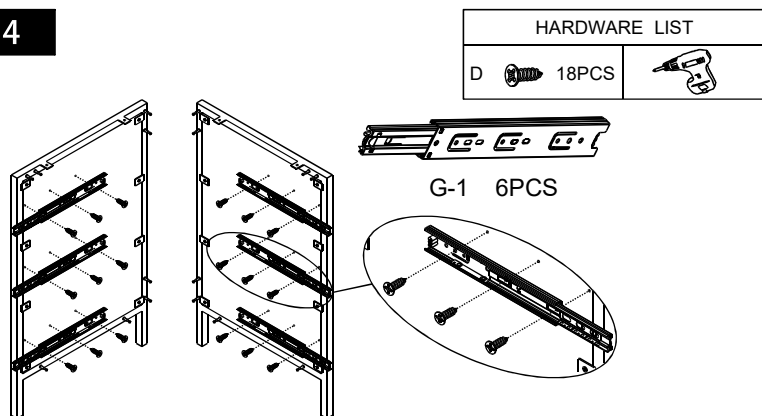

- Insert the screws to connect the slides (G-1) to the shelves.

STEP 5

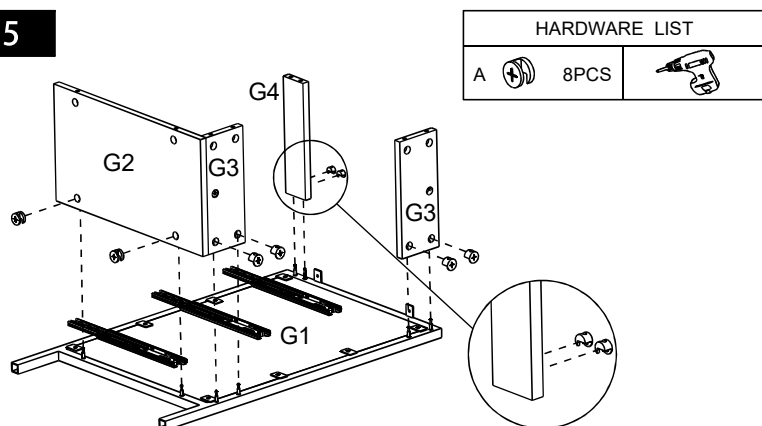

- Insert shelves G2, G3 and G4 downwards to their corresponding positions, then tighten the cam lock.



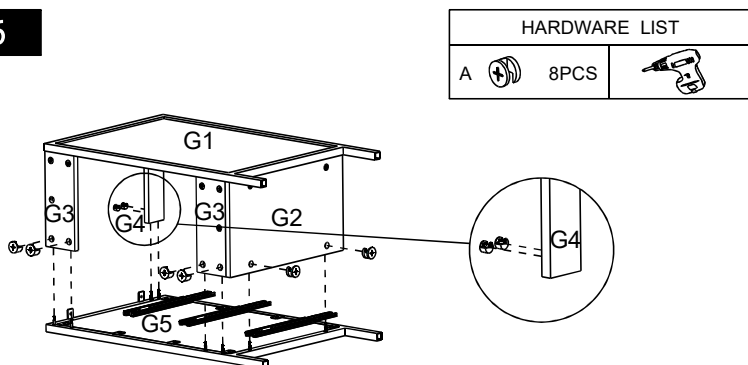

STEP 6

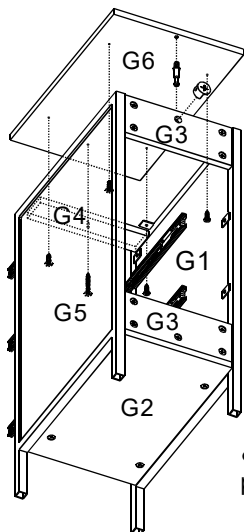

- Insert shelves G2, G3 and G4 downwards to their corresponding positions, then tighten the cam lock.

STEP 7





| HARDWARE LIST | | | |
|---------------|---|------|---|
| A |  | 1PCS |  |
| C |  | 1PCS | |
| D |  | 4PCS | |
| H |  | 1PCS | |

- Insert shelves G6 to their corresponding positions and tighten the cam lock.

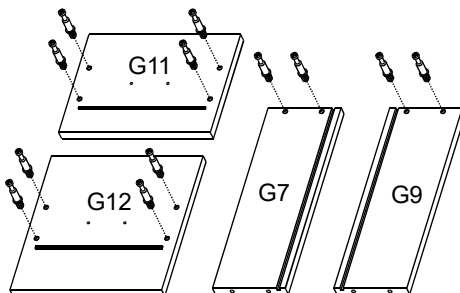
STEP 8



| HARDWARE LIST | | | |
|---------------|---|-------|---|
| C |  | 24PCS |  |

G11X2



G7X3

G9X3

- Insert the cam screw into the shelves above.

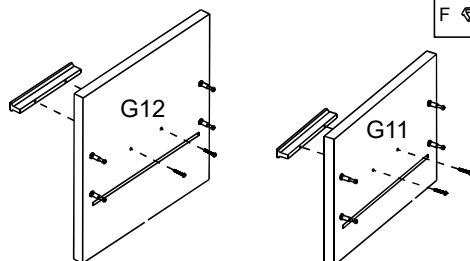
STEP 9



| HARDWARE LIST | | | |
|---------------|---|------|---|
| E |  | 6PCS |  |
| F |  | 3PCS | |

G11X2

- Secure the handle and drawer plate G11 or G12 with hascrews.

STEP 10

HARDWARE LIST

A  12PCS

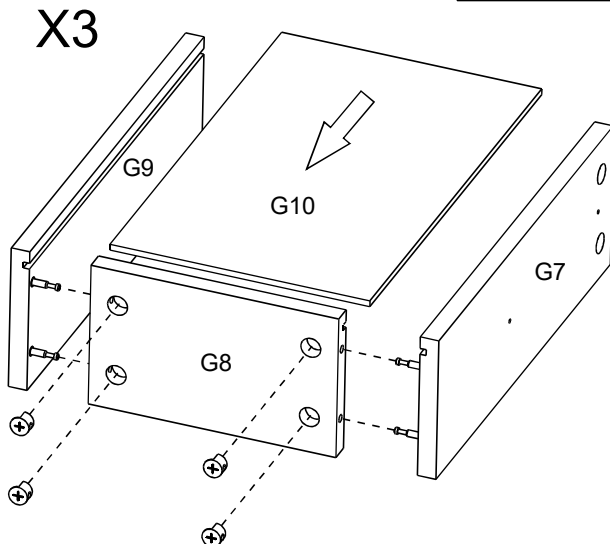

- Insert shelves G7,G8 and G9 to their corresponding positions and tighten the cam lock.Then insert the drawer bottom G10 along the groove.

STEP 11

HARDWARE LIST

A  8PCS

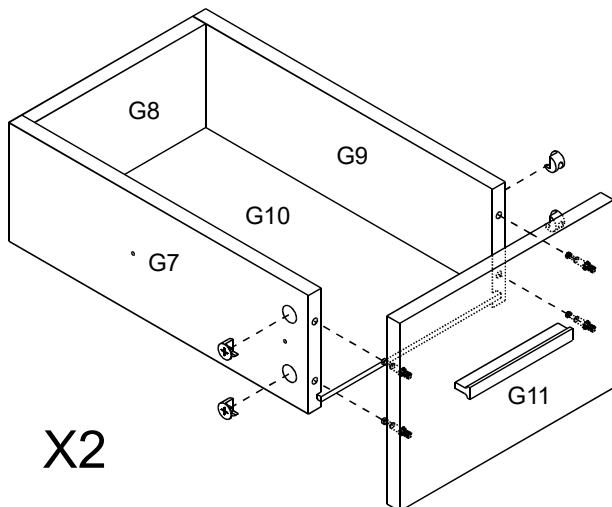

- Insert shelves G11 to their corresponding positions and tighten the cam lock.

STEP 12

HARDWARE LIST

A  4PCS

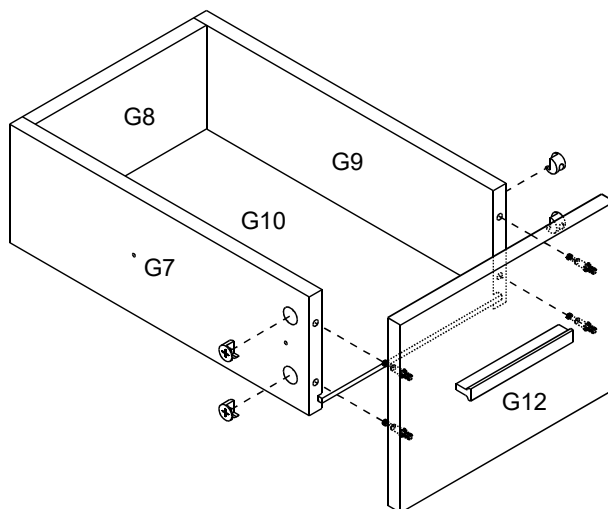

- Insert shelves G12 to their corresponding positions and tighten the cam lock.

STEP 13

HARDWARE LIST

D  12PCS



G-2 6PCS

X3

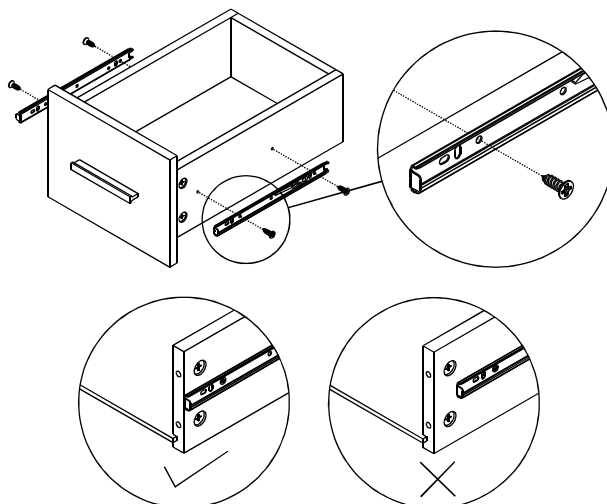

- Insert the screws to connect the slides (G-2) to the shelves.

STEP 14

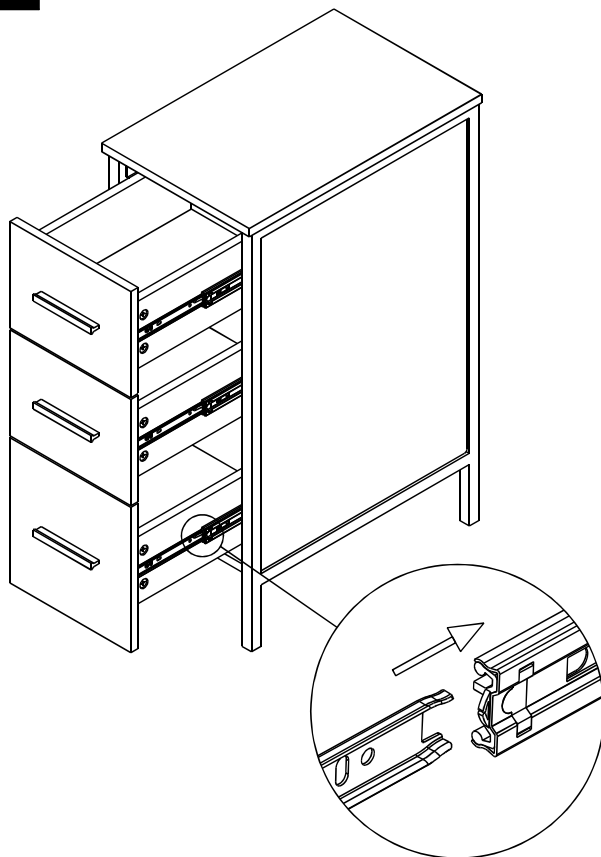

DIMENSIONS

1. Many cleansers contain abrasive and chemical substance which is not suitable for cleaning stainless steel, enamel, plating or plastic products. You may use mild cleansers or soaps to clean the surfaces. Wipe any splashes of cleaner solutions from the surface with a clean soft cloth.

2. Maintain ventilation in the bathroom and separate the dry area from the damp one if conditions permit. Try to open the door and windows of the bathroom to maintain adequate ventilation.

3. To maintain the cabinet door, clean and wipe the door regularly with a soft cloth. Wipe condensation with a dry, soft cloth. Keep away from fires and high temperatures.



FEEDBACK ★★★★★

Thank you very much for purchasing from us.

We have always been trying to provide the best service and reliable products for every customer.

We sincerely hope you will be satisfied with our products and leave us FIVE STARS and POSITIVE feedback/review in our page.

However, accident may happen sometimes, please contact us to resolve any issue before leaving a negative feedback.

Many thanks and welcome to our shop again!

Contact number: (323) 393-8260

E-mail: service@eclifeusa.com