

# Assembly Instructions

Your recliner comes packaged in three boxes. Carefully remove all of components from the packaging and set aside for assembly.

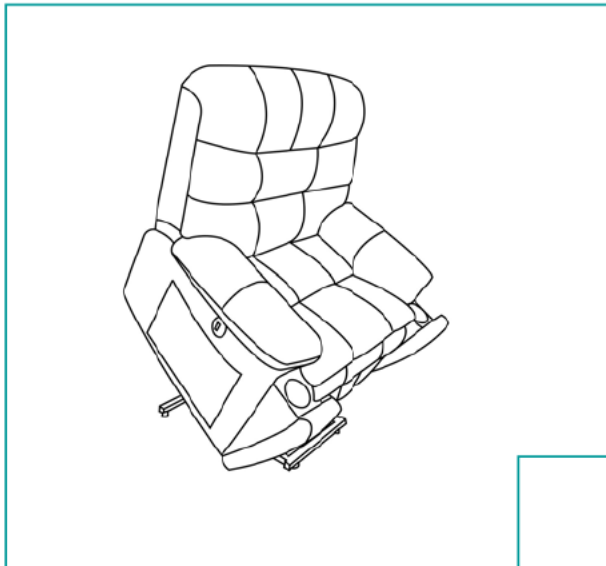

**Recliner:** reclines the chair to 135 degrees, back and footrest work together fully powered by the remote to release the built-in footrest.

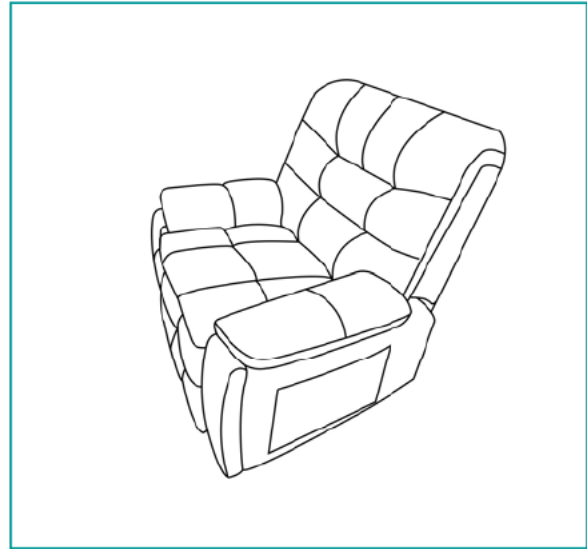





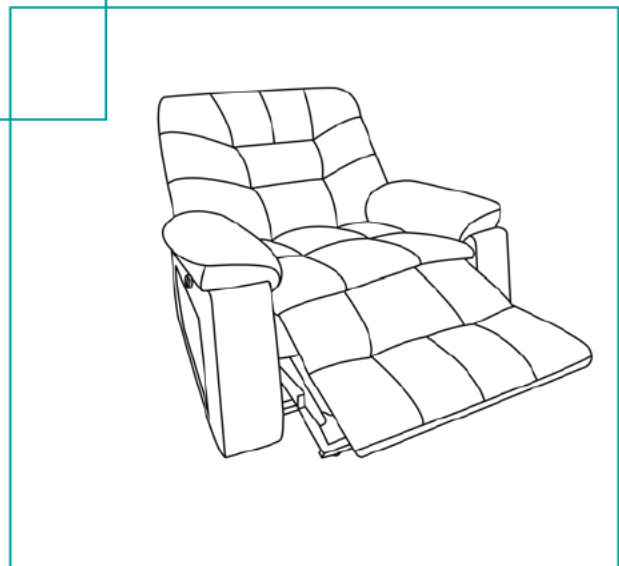

**LIFT MECHANISM:** push the entire chair up from its base to help the senior to stand.

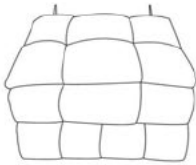

**Deluxe Design:** this lift chair is the perfect companion for any media room or living room.

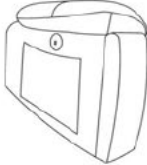

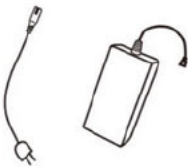
## FITTING LIST

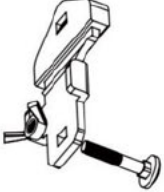
			
<b>BOX 1</b>	<b>BOX 2</b>	<b>BOX 3</b>	
A 1*Chair Seat	B 1*Chair Back	C 1*Left Armrest	D 1*Right Armrest
			
E Massage Remote	F Power Source	G Power Cord	H 2*Supporting Feet

## ASSEMBLY

**STEP 1:** Place the **Chair Seat (A)** on its back on a flat smooth surface. Take out **Supporting Feet (H)** from a small plastic bag. Assemble the two supporting feet as shown on the bottom of mechanism to avoid toppling and falling.

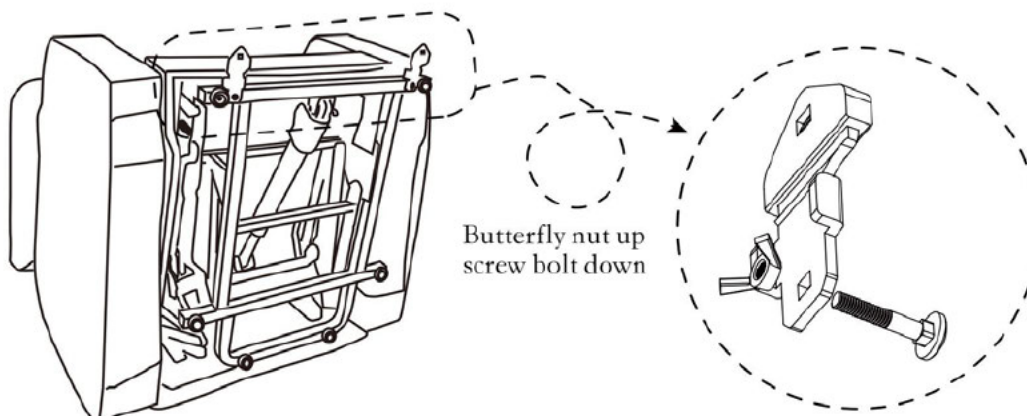

- **STEP 2:** Insert two **armrests** to the **Chair Seat (A)**, make sure the slots on the armrests fully assembled to the bottom part.

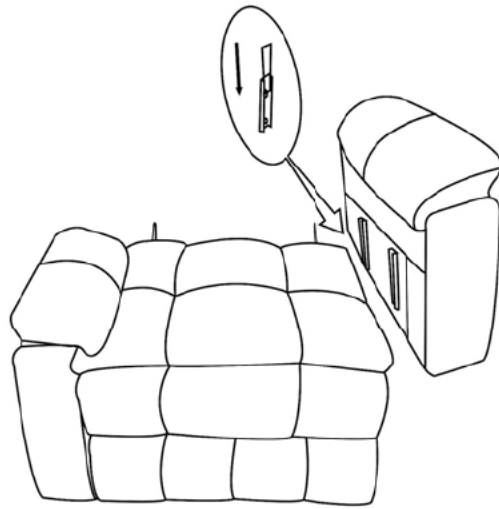

- **STEP 3:** Insert **Backrest (B)** to the **Chair Seat (A)** , make sure the slots on the back fully assembled to the bottom part.

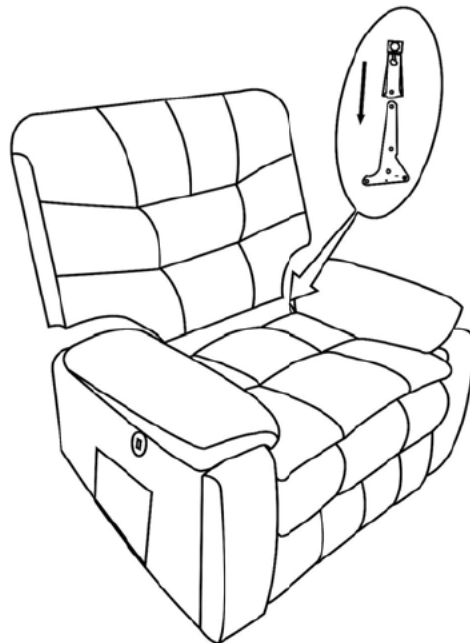

No.1 and No.2 wire connect with the backrest and chair seat.

No.3 wire connects with backrest and power cord(G).

No.4 wire connects with backrest and massage remote(E).

No.5 wire connect the motor and the wire from rightside armrest which use to connect the control panel.

No.6 wire connect the motor and power source (F).

**NOTE**

1. Two same color wires connect.
2. Plug both the Power Cord(G) and Power Source (F) into outlet to get the recliner working.

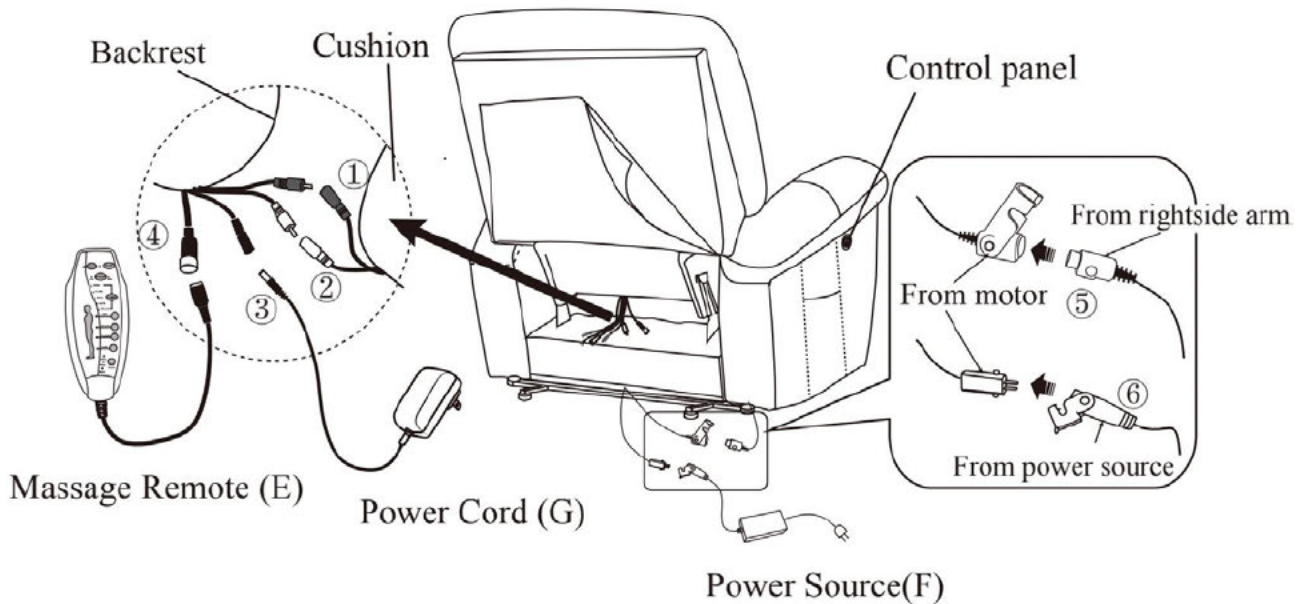

## USAGE INFORMATIONS

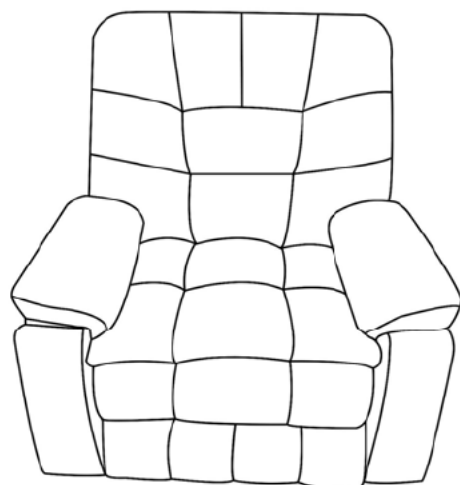

## Warnings

1. Please check if the components of the chair are all included and can be used normally as the 5<sup>th</sup> tip.
2. Assemble all components according to the instruction correctly before you connect the chair with the power.
3. Please DO NOT sit on the armrests and footrest to eliminate the risk of tipping over.
4. If the sofa is damaged or doesn't match the website product, please send clear pictures of the product and label of the carton to our service team, and we'll help you to solve the problem.
5. If the recliner doesn't work, you can try the following measures for self-checking firstly:
  - ① Check if all the cable are connected;
  - ② Check if the light of transformer is on.If the chair still doesn't work, please feed the information back to the customer service in time. We will help solve the problem for you as soon as possible.

