

# ASSEMBLY INSTRUCTIONS



# ASSEMBLY INSTRUCTIONS

## ASSEMBLY TIPS:

1. Remove hardware from box and sort by size.
2. Please check to see that all hardware and parts are present prior to start of assembly.
3. Please follow attached instructions in the same sequence as numbered to assure fast & easy assembly.



### WARNING !

1. Don't attempt to repair or modify parts that are broken or defective. Please contact the store immediately.
2. This product is for home use only and not intended for commercial establishment.

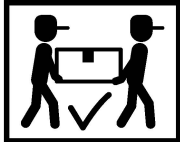

**ASSEMBLY TIME 20 MINUTE**

## PARTS IDENTIFICATION

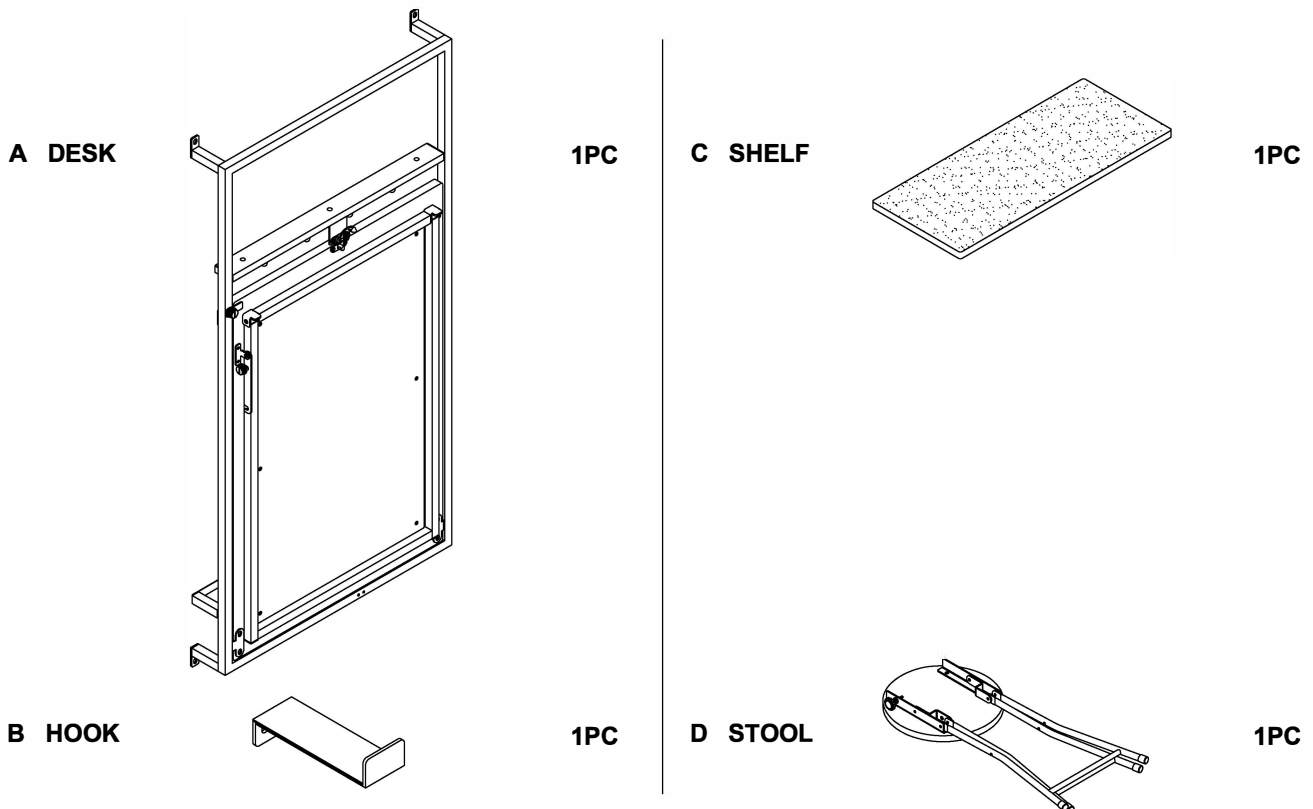

## HARDWARE IDENTIFICATION



1	<b>BOLT</b> (1/4"x1" - BLK)		3PCS	5	<b>SCREW</b> (φ4 x 26mm - BLK)		4PCS
2	<b>BOLT</b> (3/16"x1/2" - BLK)		2PCS	6	<b>PLASTIC DOWEL</b>		4PCS
3	<b>WASHER</b> (φ16mm - BLK)		3PCS	7	<b>ALLEN KEY</b> (4x22x60mm - BLK)		1PC
4	<b>WASHER</b> (φ12mm - BLK)		2PCS				

### NOTE:

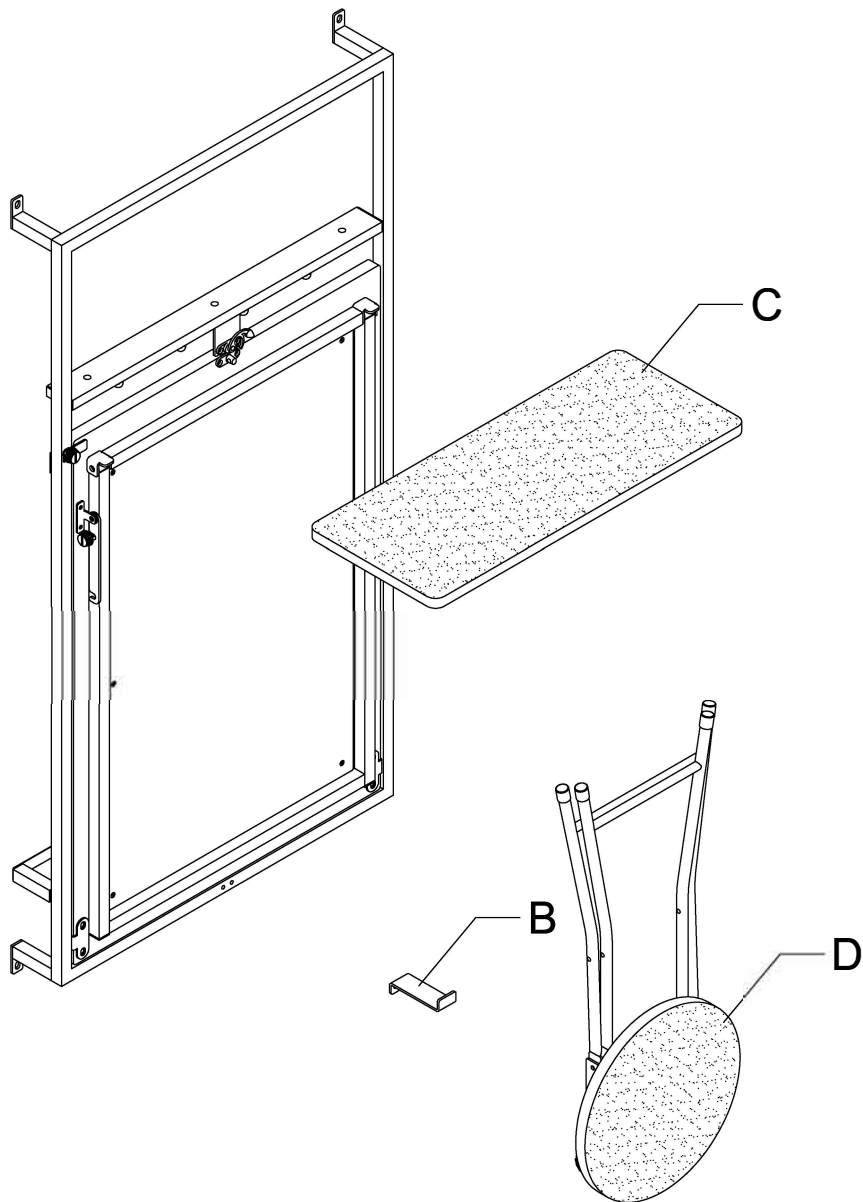
Phillips head screw driver is required in the assembly process; however, manufacturer does not provide this item.



# ASSEMBLY INSTRUCTIONS

1		3PCS
3		3PCS
7		



## STEP 1:

### ASSEMBLY

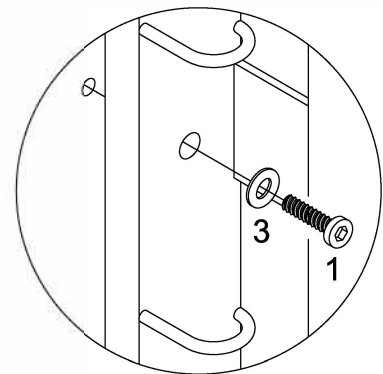
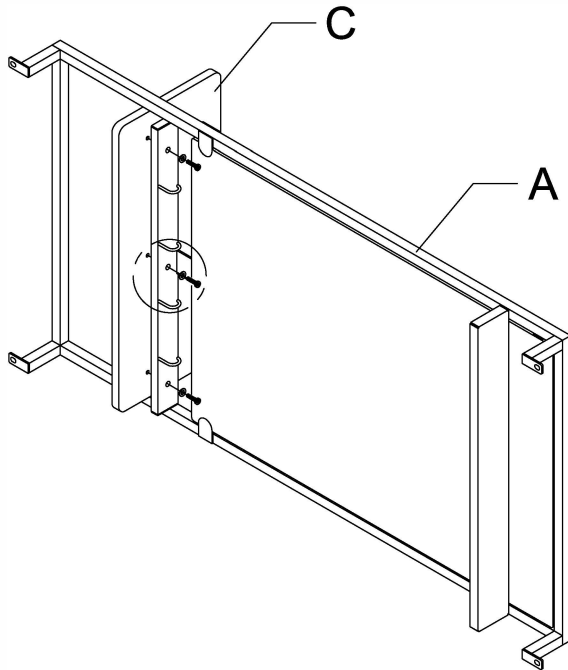
Do not fully tighten all bolts until assembly is complete.  
This will help all parts to assemble properly.



## STEP 2:

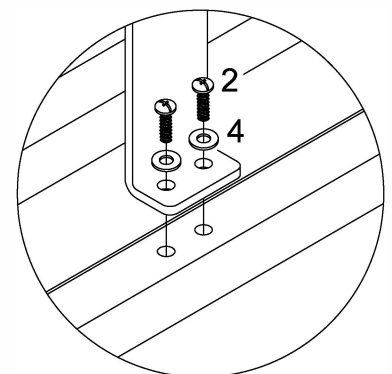
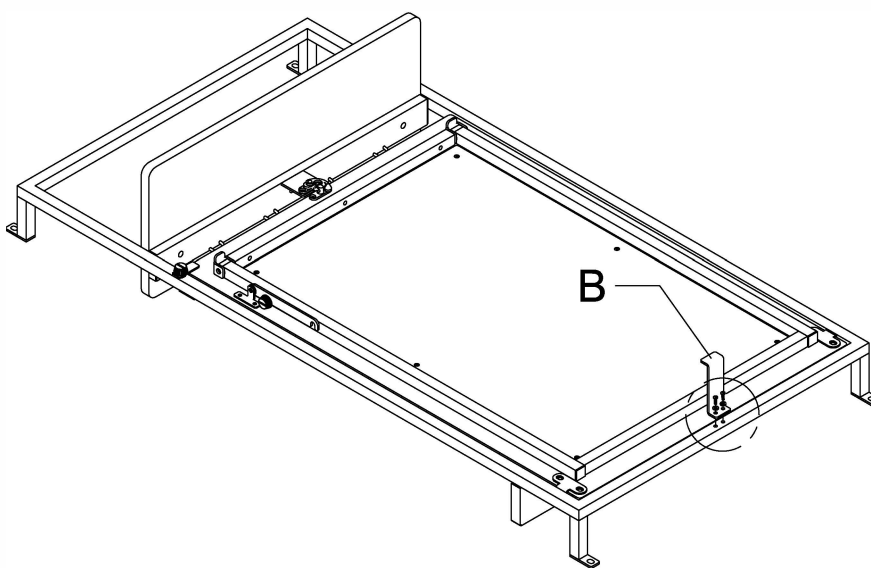

2		2PCS
4		2PCS



### STEP 3:

Remark:

Before assembling this step, please drill 4 holes on the wall in advance, and the positions of the 4 holes are as indicated below.

4		4Pcs
5		4Pcs
6		4Pcs

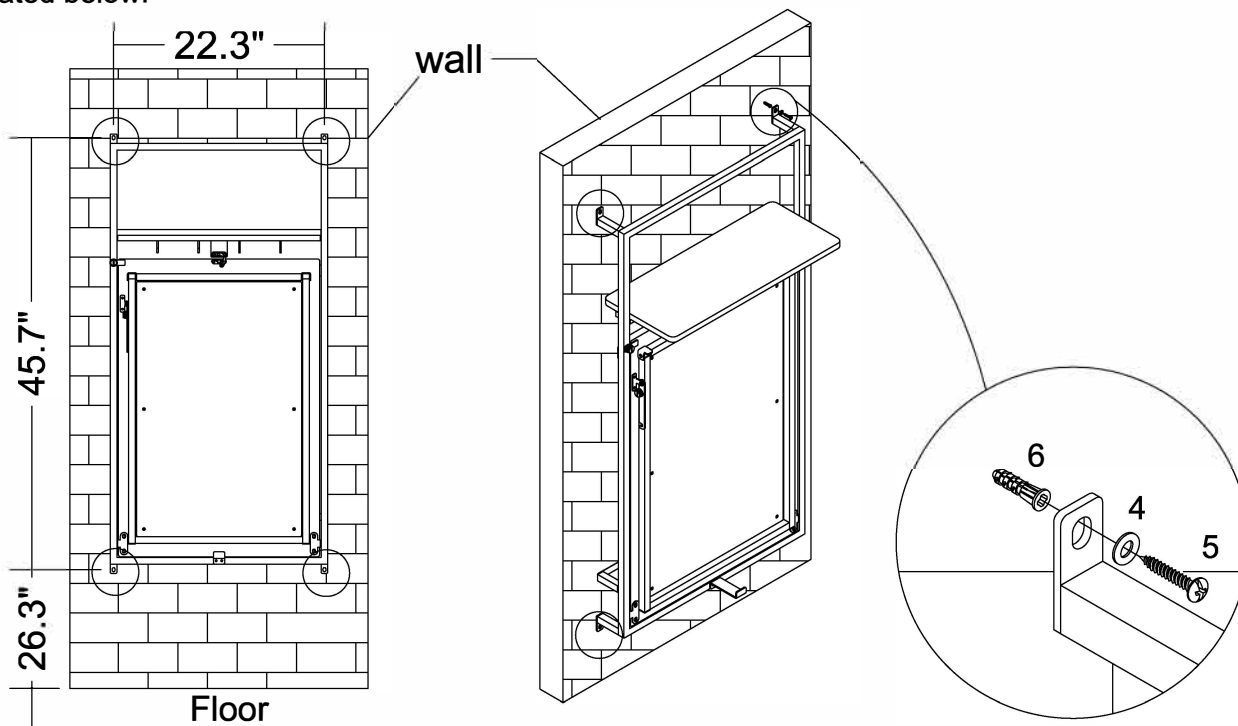

### STEP 4:

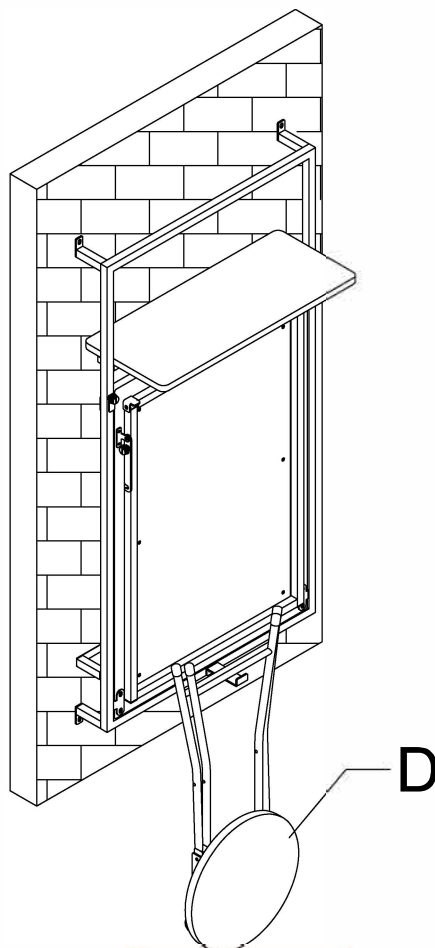

## STEP 5:

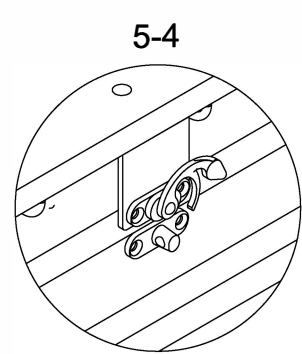
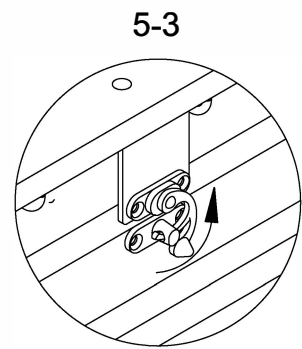
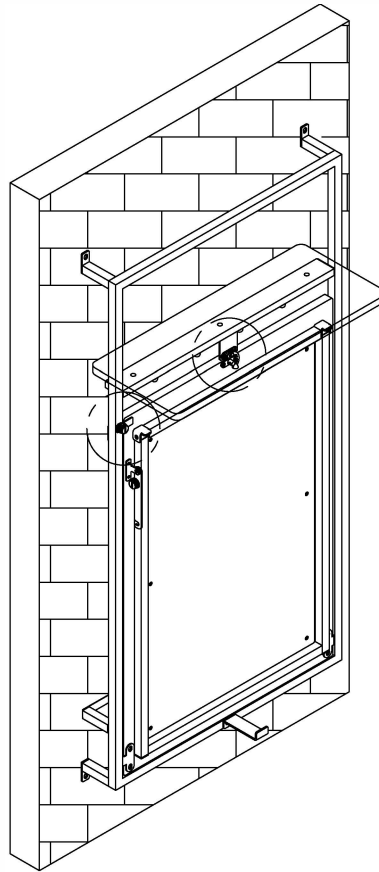
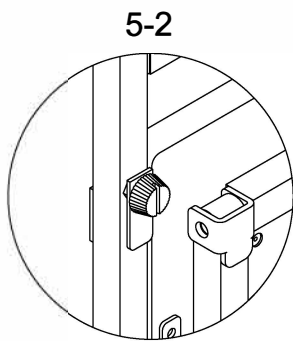
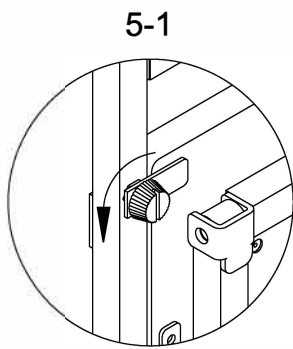

**Warning!**  
Please be careful with your finger  
while you unfolding the desk.

## STEP 6:

**Warning!**  
Please be careful with your finger  
while you unfolding the desk.

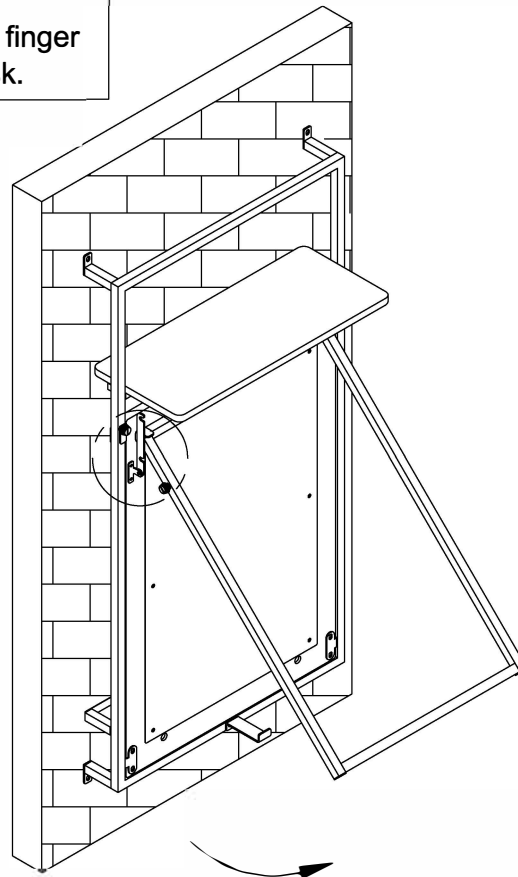
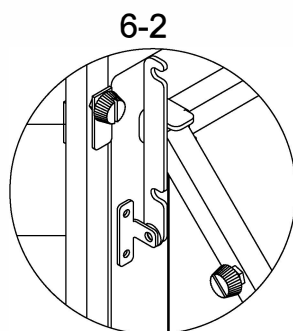
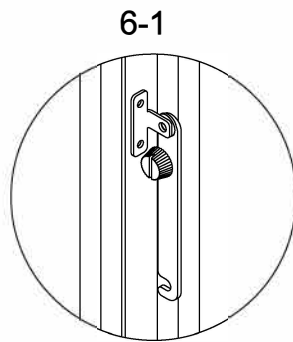

## STEP 7:

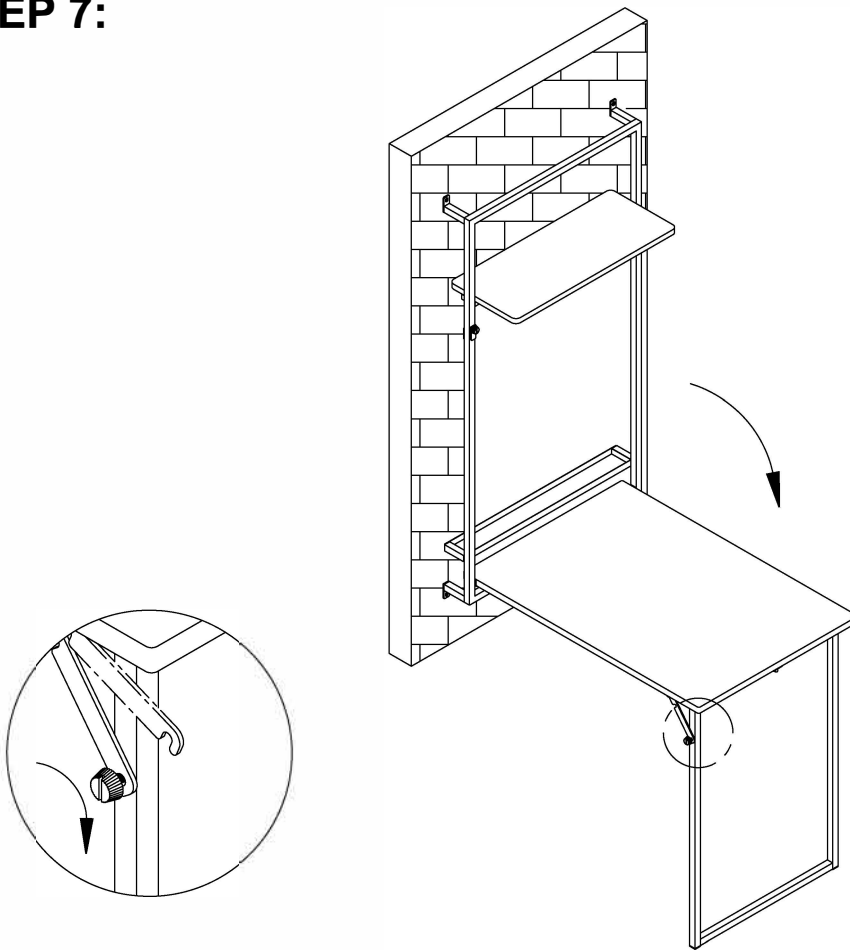

## STEP 8:

**Warning!**  
Please be careful with your finger  
while you unfolding the stool.

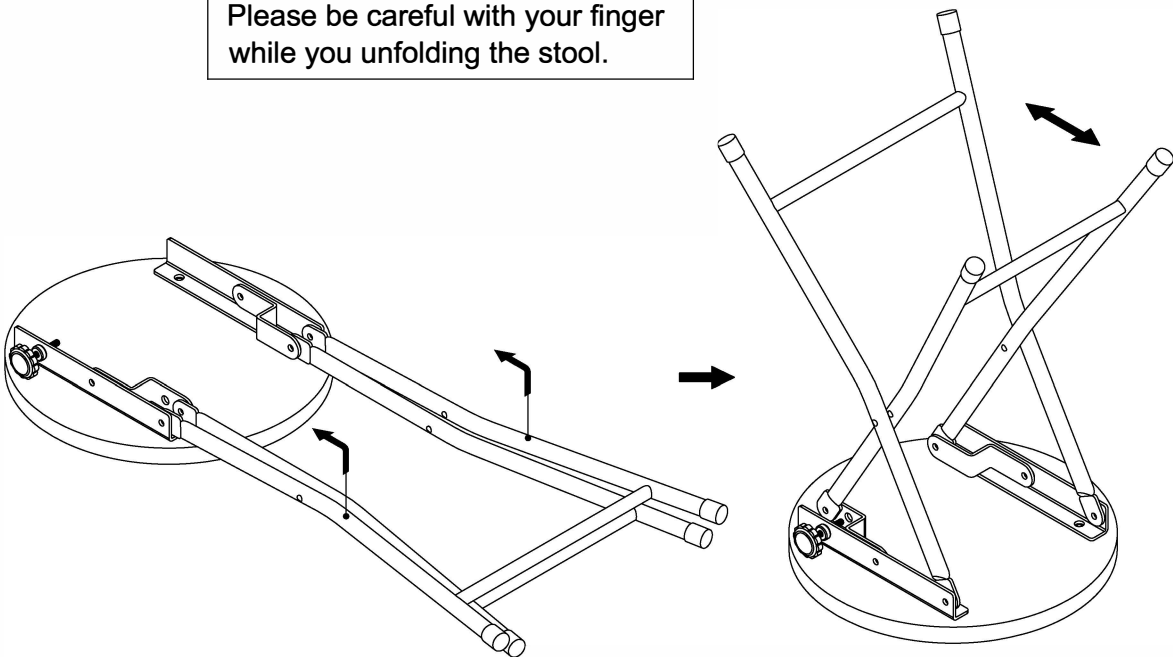

## STEP 9:

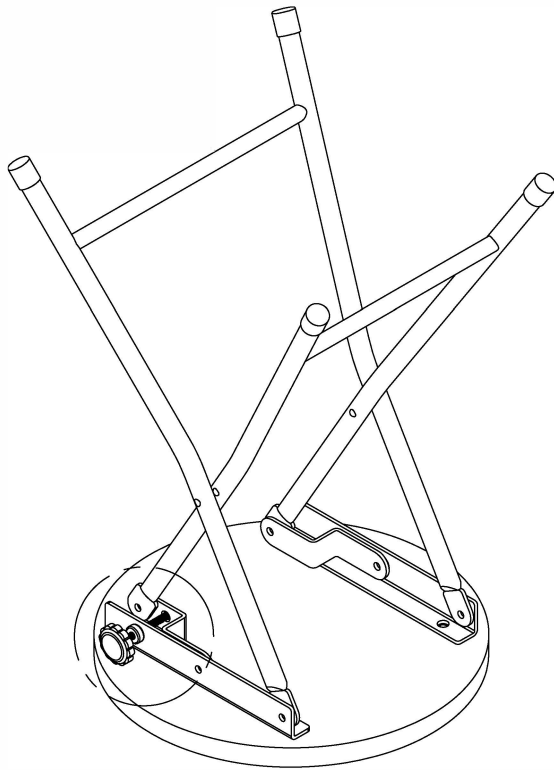

### Warning!

Please fasten the adjusting knob on the back of the stool before using the stool

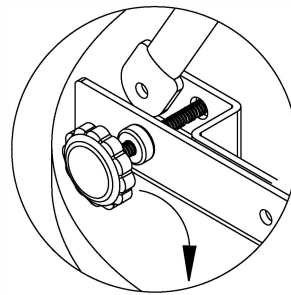

## STEP 10:

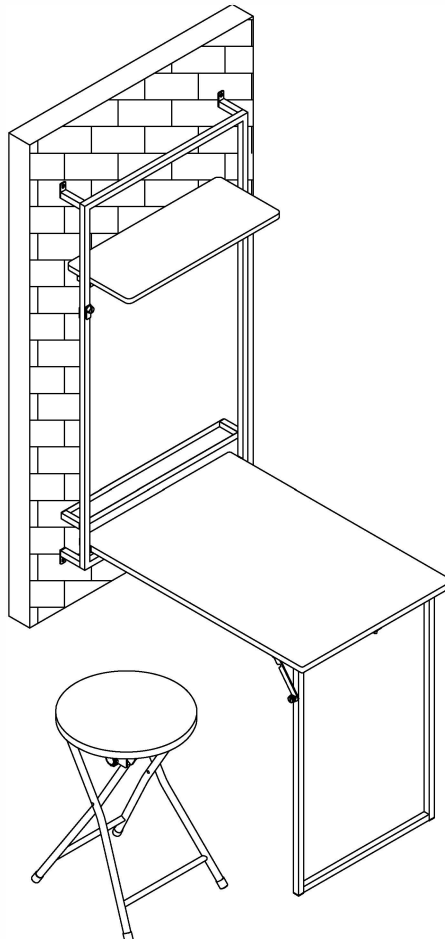

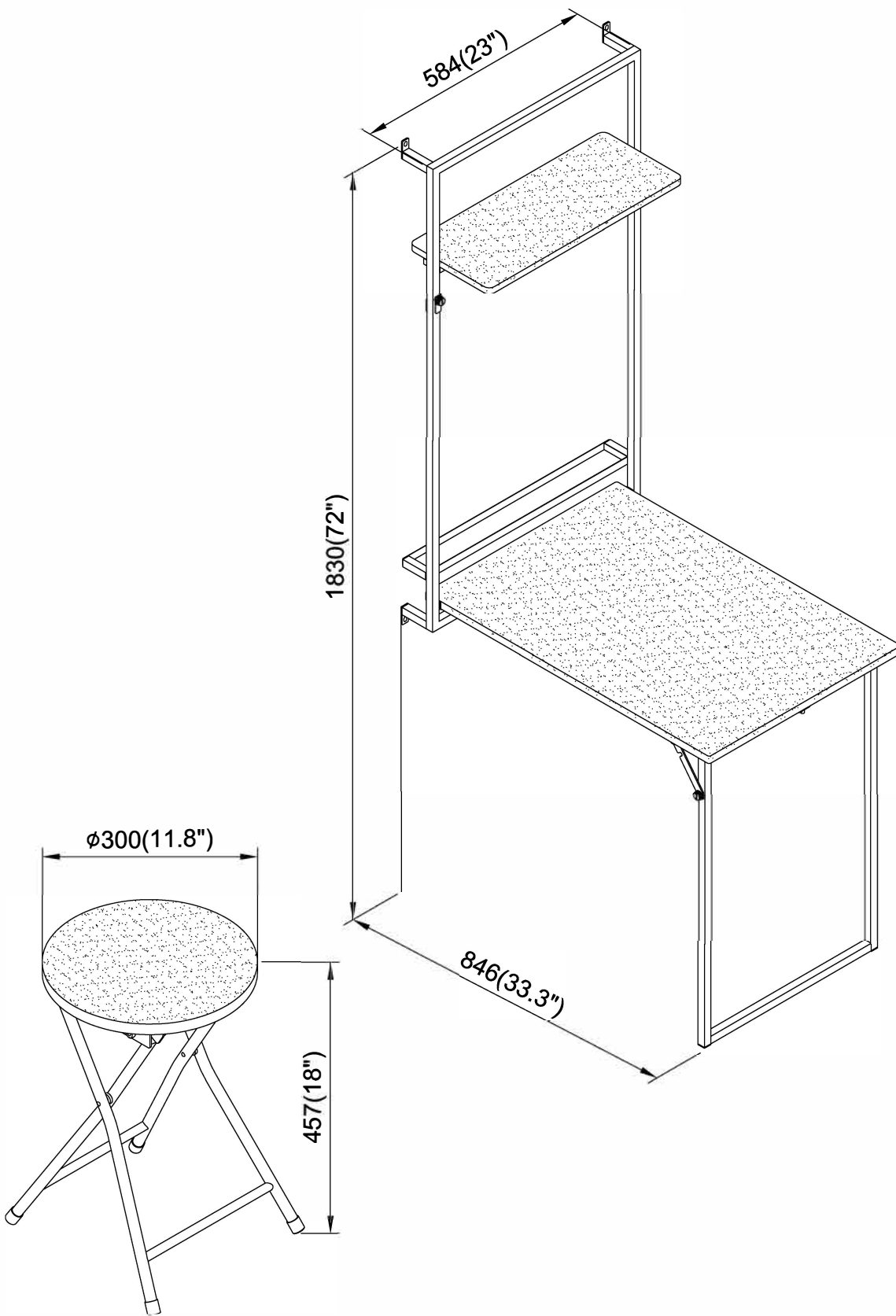

Note : Dimension tolerance  $\pm 5\%$