

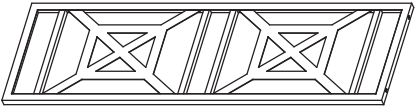

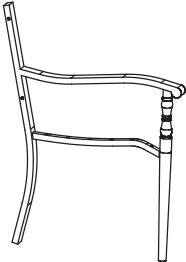



USER'S MANUAL

Metal Garden Bench

PRODUCT ASSEMBLY

Board Identification		
	AX1	Back
	BX2	Arms
	CX6	Seat slats

Hardware List		
M6X35mm		BOLT
	DX12	
M6X55mm		BOLT
	EX4	
M6		WASHER
	FX16	
4X4		ALLEN WRENCH
	GX1	

PRODUCT ASSEMBLY

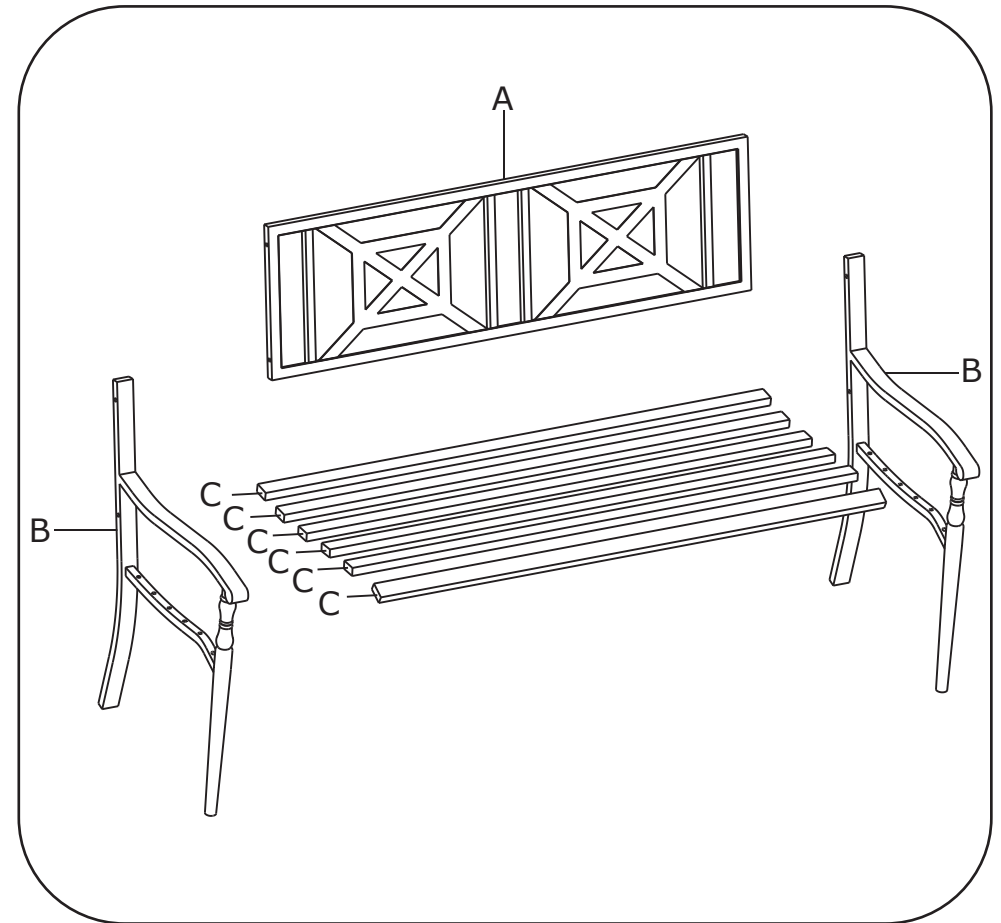

PRODUCT ASSEMBLY

STEP1

Attach the seat slat (C) to the arm (B) by bolts (D) with washers (F) through the pre-drilled holes on the arm into the pre-welded nuts on the seat slat.

Repeat step for the other side arm(B).

IMPORTANT: Do not tighten completely until assembly is completed.

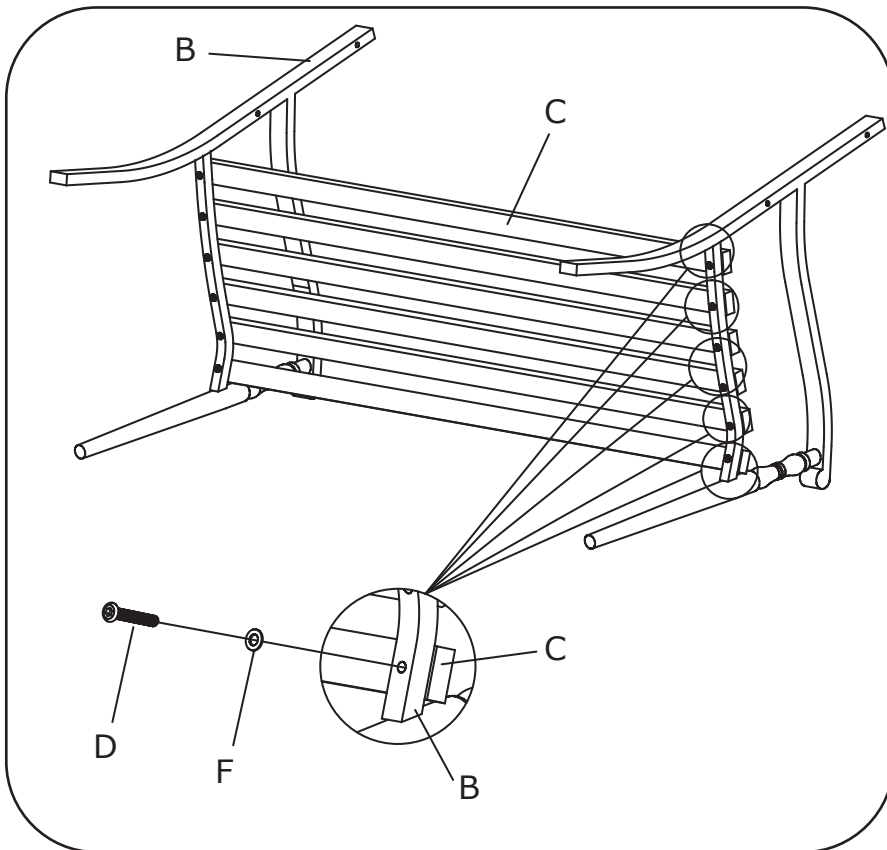

PRODUCT ASSEMBLY

STEP2

Attach the back (A) to the arm (B) by inserting bolts (E) with washers (F) through the pre-drilled holes on the arm into the pre-welded nuts on the back.

Repeat step for the other side arm(B).

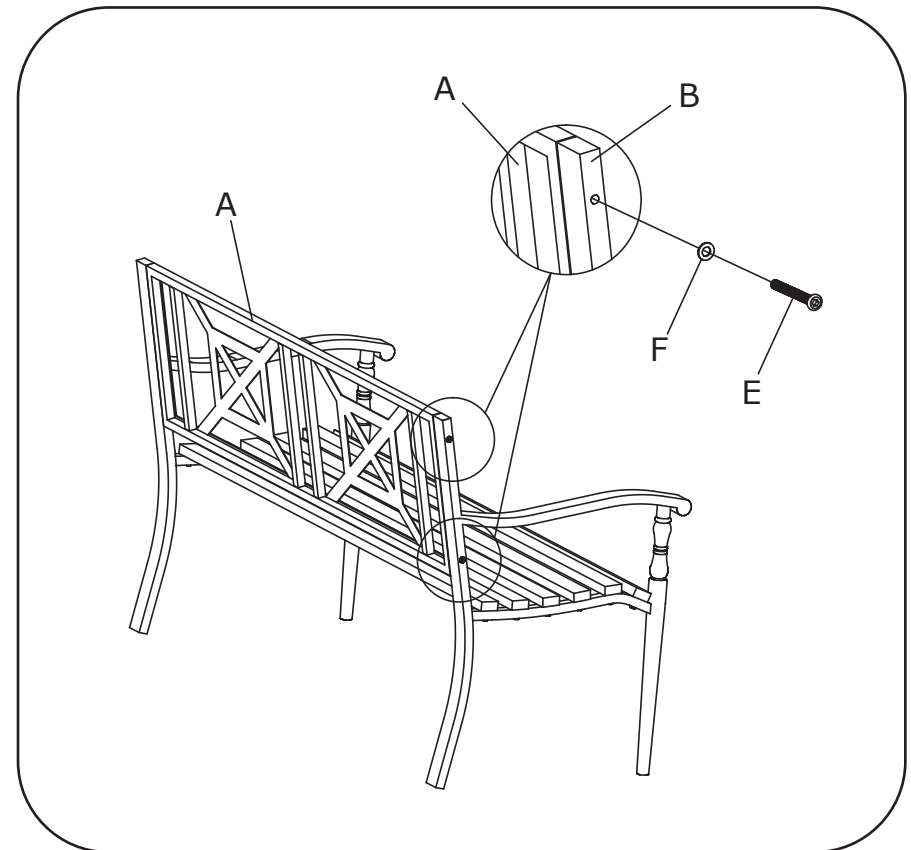

PRODUCT ASSEMBLY

STEP3

Tighten all the bolts with the allen wrench, and turn the bench to the upright position.

Your bench is now ready for use, so relax & enjoy!

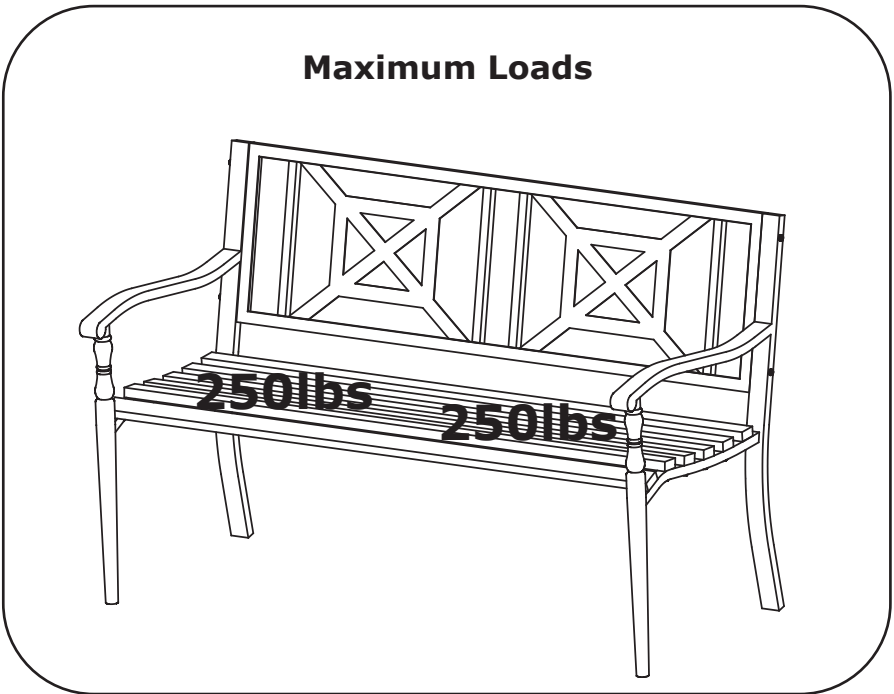

WARNING!

This item is only suitable within the specified maximum load-bearing. Heavier loads than the indicated load capacity may cause instability, resulting in possible injuries.