







ASSEMBLY INSTRUCTIONS

Don't tighten any Bolts until all Bolts on a step have been started.

Thank you for purchasing this quality product. Be sure to check all packing material carefully for small parts, which may have come loose inside the carton during shipment. Identify and count all parts and compare with the HARDWARE LIST below.

NO.	PARTS LIST	PARTS NO.	Q' TY
A	 Wooden Seat	B1130-25WP1	1
	Top Ring	B1100-25WP2	pre-assy
B	 Swivel	B1100-25WP3	1
	Middle Ring	B1100-25WP4	pre-assy
C	 Bottom Ring	B1100-25WP5	1
D	 Leg	B1100-25WP6 / B1100-30WP6	4

NO.	PARTS LIST	PARTS NO.	Q' TY
1	 $\phi 1/4" \times 5/8"$ Bolt	B1100-25WP7	8
2	 $\phi 1/4" \times 1/2"$ Bolt		8
3	 Allen Wrench		1

STEP 1

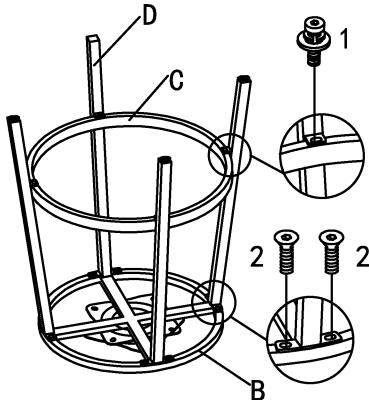

1. Attach the four Legs (D) to the Middle Ring w/ swivel (B), using Bolts (2) and Allen Wrench (3) to tighten, as shown
2. Attach the Bottom Ring (C) to the Legs, using Bolts (1) and Allen Wrench (3) to tighten, as shown.

STEP 2

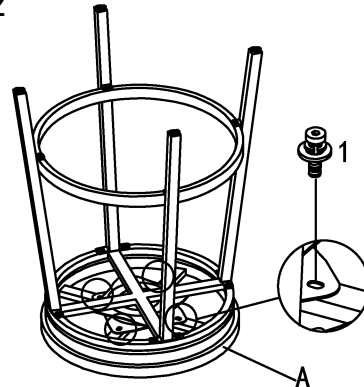

1. Upside down the Wooden Seat w/ top ring (A) and put it on a smooth and stable working stand.
2. Attach the assembled Legs frame to the Wooden Seat w/ top ring (A), using Bolts (1) and Allen Wrench (3) to tighten, as shown.

STEP 3

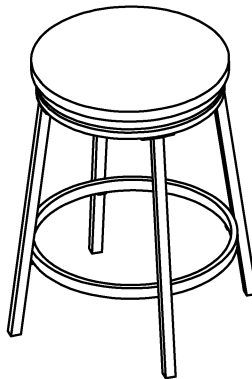

1. Right side up the stool.
2. It's complete for using.

Caution: 1. All bolts must be tightened mandatorily in each step.
2. It is also mandatorily recommended to periodically check bolts and retighten as needed.