

LAF Loveseat

IMPORTANT

Carefully remove all the parts from the carton and place them individually on a soft cloth to prevent scratches or other damage.

Carefully and strictly follow these assembly instructions to ensure a completed product as designed.

Do not use power tools above 8 volts to assemble.

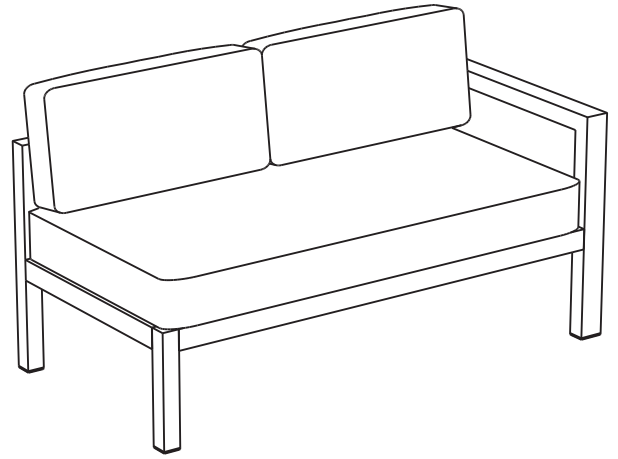

Part List

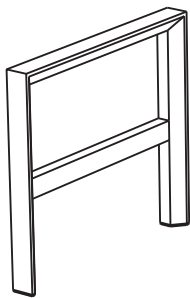

A.
Arm
1 pc.

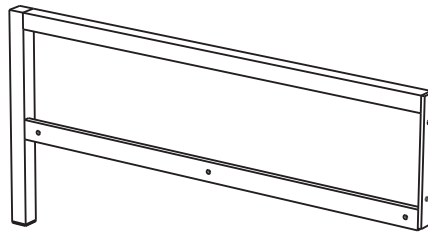

B.
Back
1 pc.

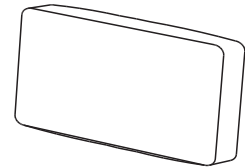

L.
Back Cushion
2 pcs.

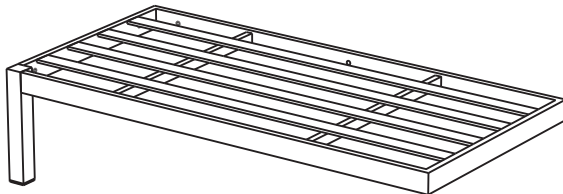

C.
Seat
1 pc.

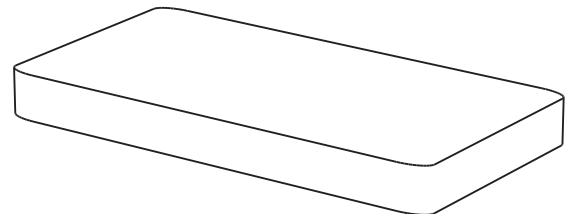

J.
Seat Cushion
1 pc.

Hardware List

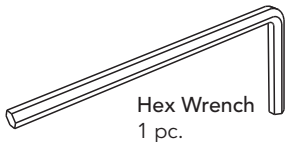

Hex Wrench
1 pc.

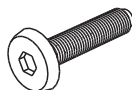

M6x25
Head Cap Bolt (short)
2 pcs. (+1 extra)



Spring Washer
8 pcs. (+1 extra)



Cap
8 pcs. (+1 extra)



Small
Hex Wrench
1 pc.

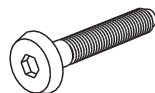

M6x35
Head Cap Bolt
6 pcs. (+1 extra)



Flat Washer
8 pcs. (+1 extra)

Assembly Instructions 2/3

IMPORTANT

- Use a soft cloth between these parts and the floor.
- Do not use power tools above 8 volts to assemble.
- Do not tighten all the bolts until each part is properly assembled.
- Keep Hex Wrench as the bolts may need to be tightened in the future.

Left Unit

STEP 1

Attach Seat (C) to Back (B) with Head Cap Bolts, Spring Washers and Flat Washers, tightening bolts only halfway. (See Figure 1)

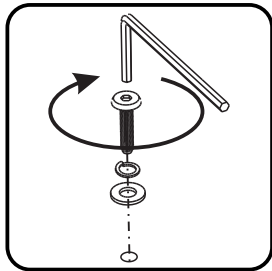
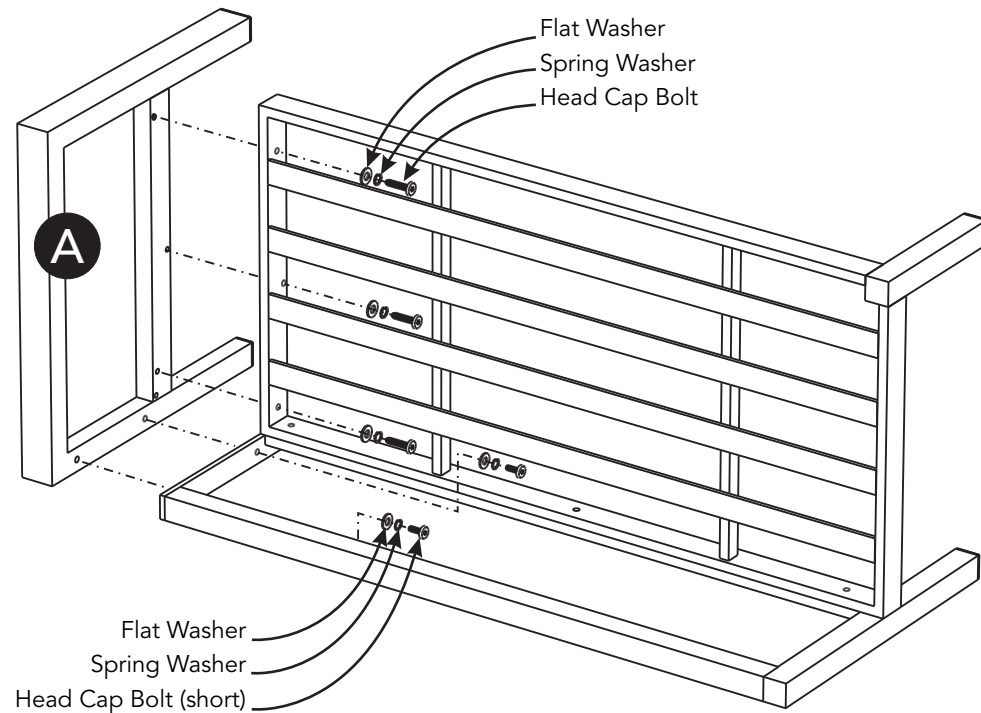
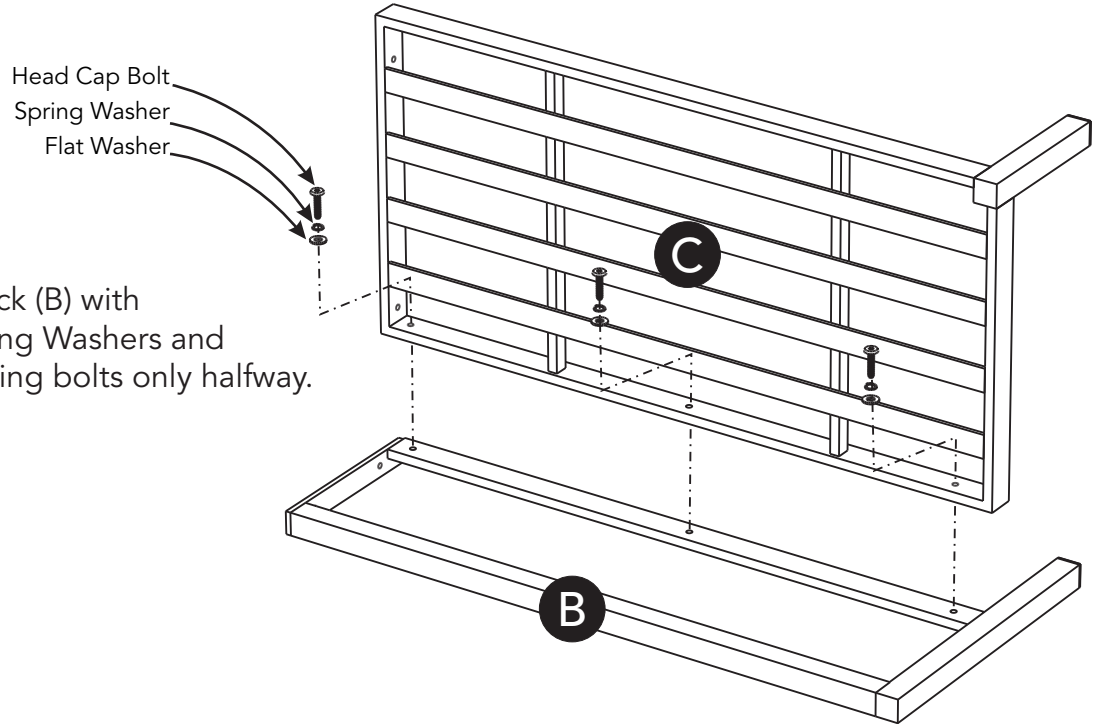

Figure 1



STEP 2

Attach Arm (A) to unit with Head Cap Bolts, Head Cap Bolts (short), Spring Washers and Flat Washers, tightening bolts only halfway.

Assembly Instructions 3/3

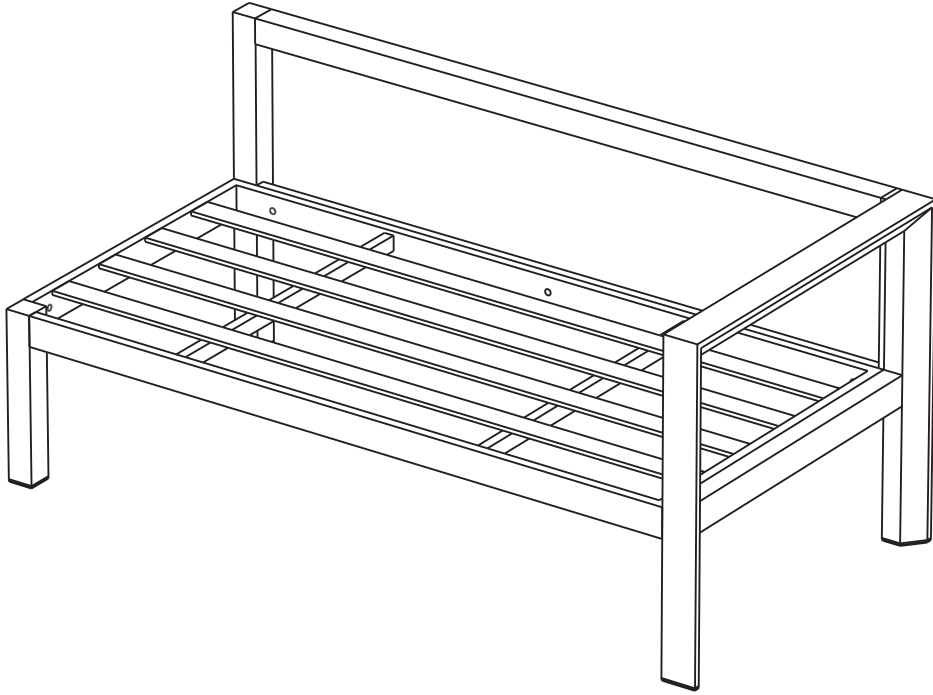

STEP 3

Tighten all bolts used in Steps 1 and 2.

Cover all Head Cap Bolts with Caps. (See Figure 2)

Turn unit to its upright position.

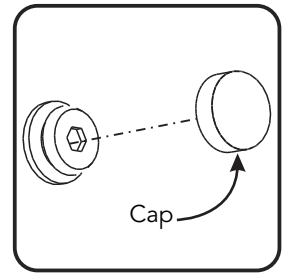

Figure 2

RAF Loveseat

IMPORTANT

Carefully remove all the parts from the carton and place them individually on a soft cloth to prevent scratches or other damage.

Carefully and strictly follow these assembly instructions to ensure a completed product as designed.

Do not use power tools above 8 volts to assemble.

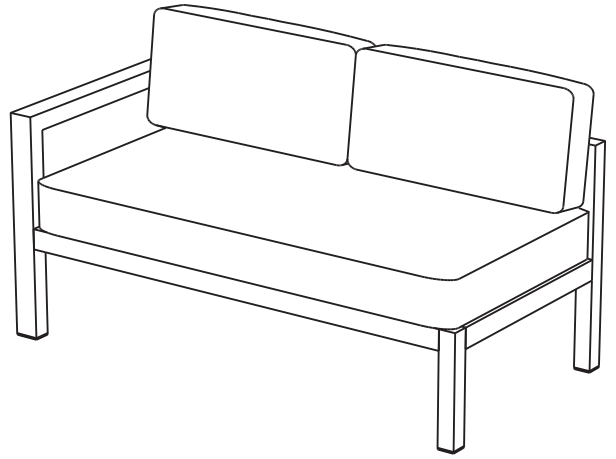

Part List

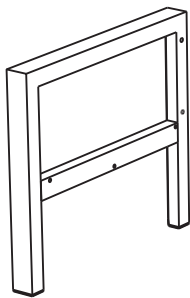

D.
Arm
1 pc.

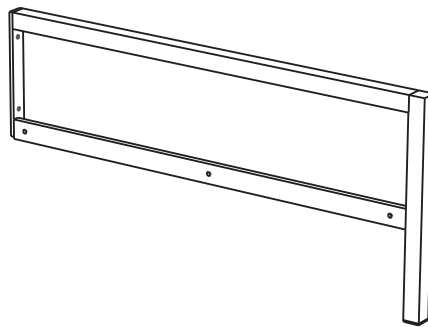

E.
Back
1 pc.

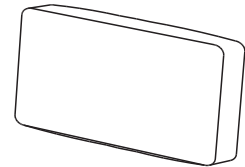

L.
Back Cushion
2 pcs.

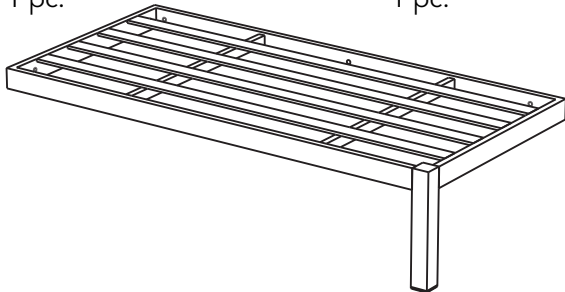

F.
Seat
1 pc.

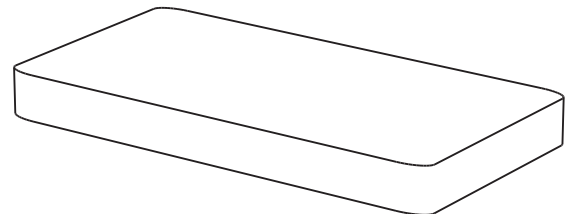

J.
Seat Cushion
1 pc.

Hardware List

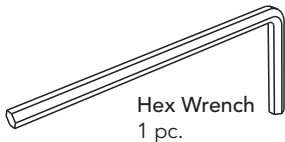

Hex Wrench
1 pc.

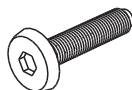

M6x25
Head Cap Bolt (short)
2 pcs. (+1 extra)



Spring Washer
8 pcs. (+1 extra)



Cap
8 pcs. (+1 extra)



Small
Hex Wrench
1 pc.

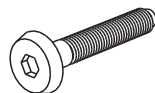

M6x35
Head Cap Bolt
6 pcs. (+1 extra)



Flat Washer
8 pcs. (+1 extra)

Assembly Instructions 2/3

IMPORTANT

- Use a soft cloth between these parts and the floor.
- Do not use power tools above 8 volts to assemble.
- Do not tighten all the bolts until each part is properly assembled.
- Keep Hex Wrench as the bolts may need to be tightened in the future.

Right Unit

STEP 1

Attach Seat (F) to Back (E) with Head Cap Bolts, Spring Washers and Flat Washers, tightening bolts only halfway. (See Figure 1)

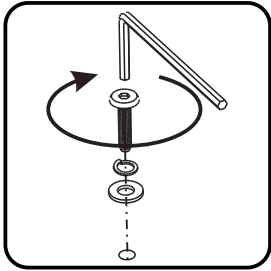
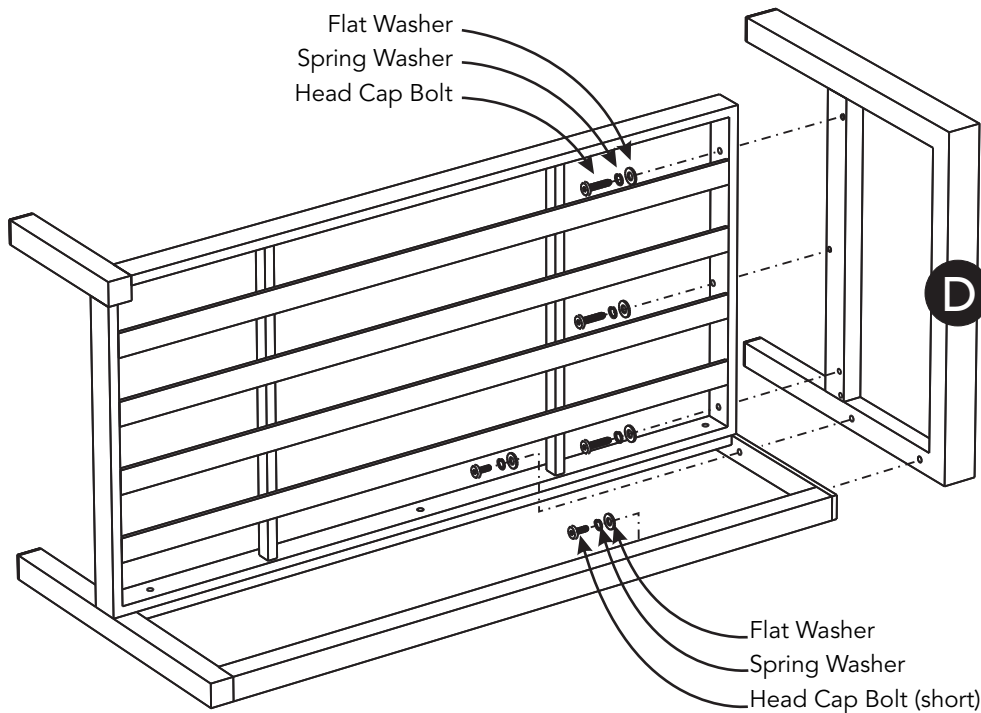
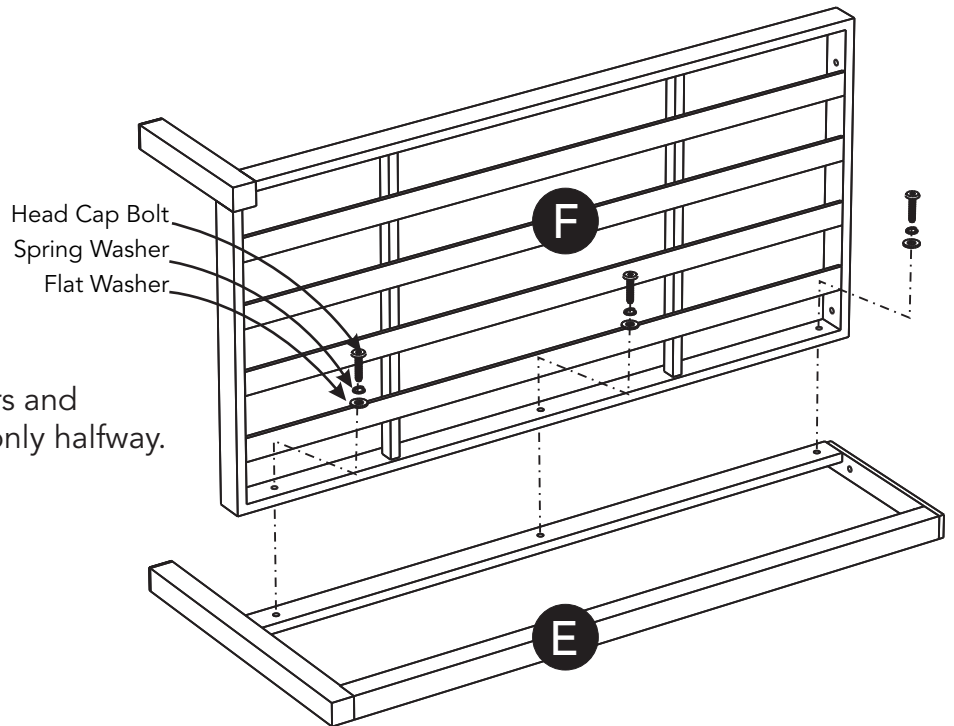

Figure 1



STEP 2

Attach Arm (D) to unit with Head Cap Bolts, Head Cap Bolts (short), Spring Washers and Flat Washers, tightening bolts only halfway.

Assembly Instructions 3/3

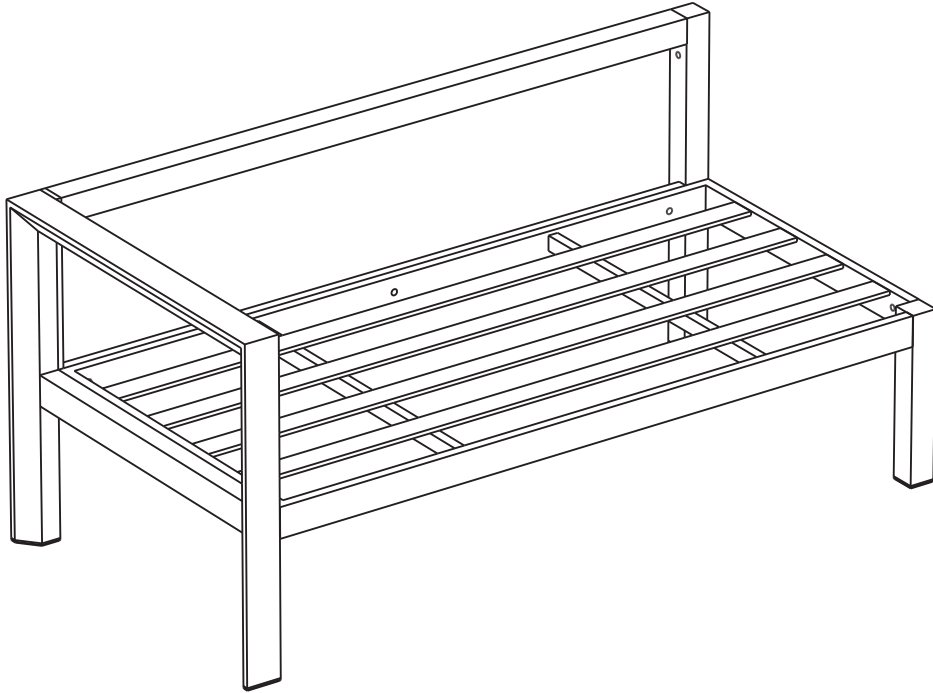

STEP 3

Tighten all bolts used in Steps 1 and 2.

Cover all Head Cap Bolts with Caps. (See Figure 2)

Turn unit to its upright position.

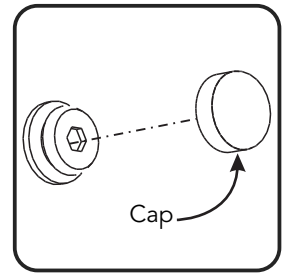

Figure 2

Corner Chair

IMPORTANT

Carefully remove all the parts from the carton and place them individually on a soft cloth to prevent scratches or other damage.

Carefully and strictly follow these assembly instructions to ensure a completed product as designed.

Do not use power tools above 8 volts to assemble.

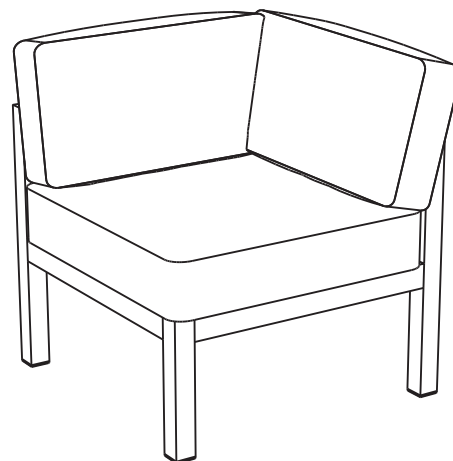

Part List

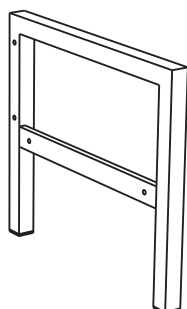

G.
Side
1 pc.

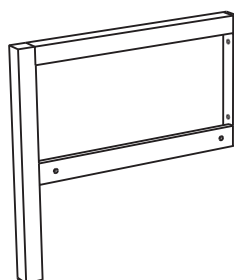

H.
Back
1 pc.

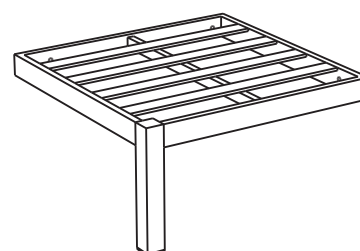

I.
Seat
1 pc.

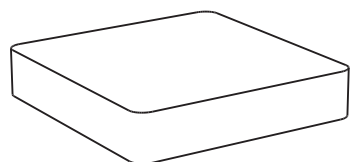

K.
Seat Cushion
1 pc.

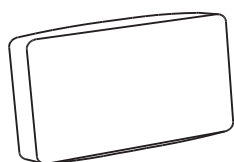

L.
Back Cushion
1 pc.

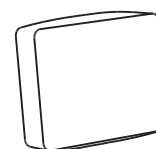

M.
Back Cushion
1 pc.

Hardware List

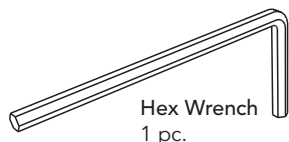

Hex Wrench
1 pc.

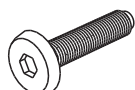

M6x25
Head Cap Bolt (short)
2 pcs. (+1 extra)



Spring Washer
6 pcs. (+1 extra)



Cap
6 pcs. (+1 extra)



Small
Hex Wrench
1 pc.

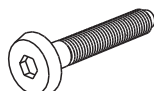

M6x35
Head Cap Bolt
4 pcs. (+1 extra)



Flat Washer
6 pcs. (+1 extra)



Clip
6 pcs. (+1 extra)

Assembly Instructions 2/4

IMPORTANT

- Use a soft cloth between these parts and the floor.
- Do not use power tools above 8 volts to assemble.
- Do not tighten all the bolts until each part is properly assembled.
- Keep Hex Wrench as the bolts may need to be tightened in the future.

Follow instructions in 6730-604, 605 cartons first, then proceed with Step 4.

Corner Unit

STEP 4

Attach Seat (I) to Back (H) with Head Cap Bolts, Spring Washers and Flat Washers, tightening bolts only halfway.

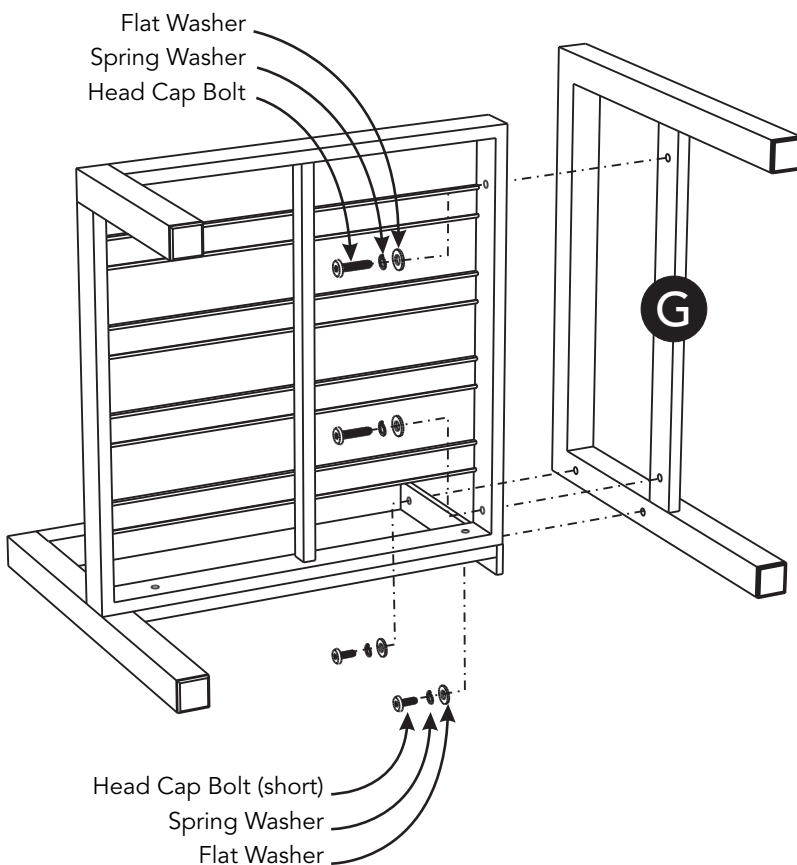
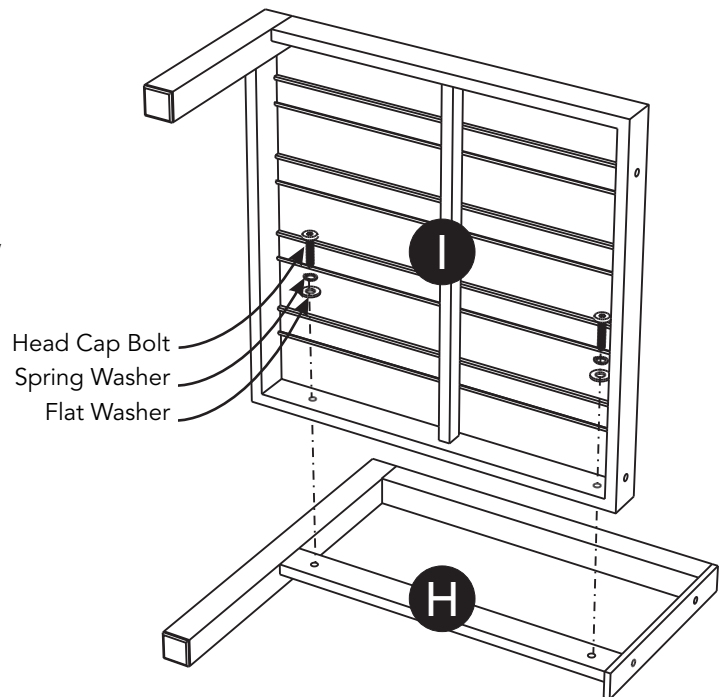

STEP 5

Attach Side (G) to unit with Head Cap Bolts, Head Cap Bolts (short), Spring Washers and Flat Washers, tightening bolts only halfway.

Tighten all bolts used.

Cover all Head Cap Bolts with Caps.

Turn unit to its upright position.

Assembly Instructions 3/4

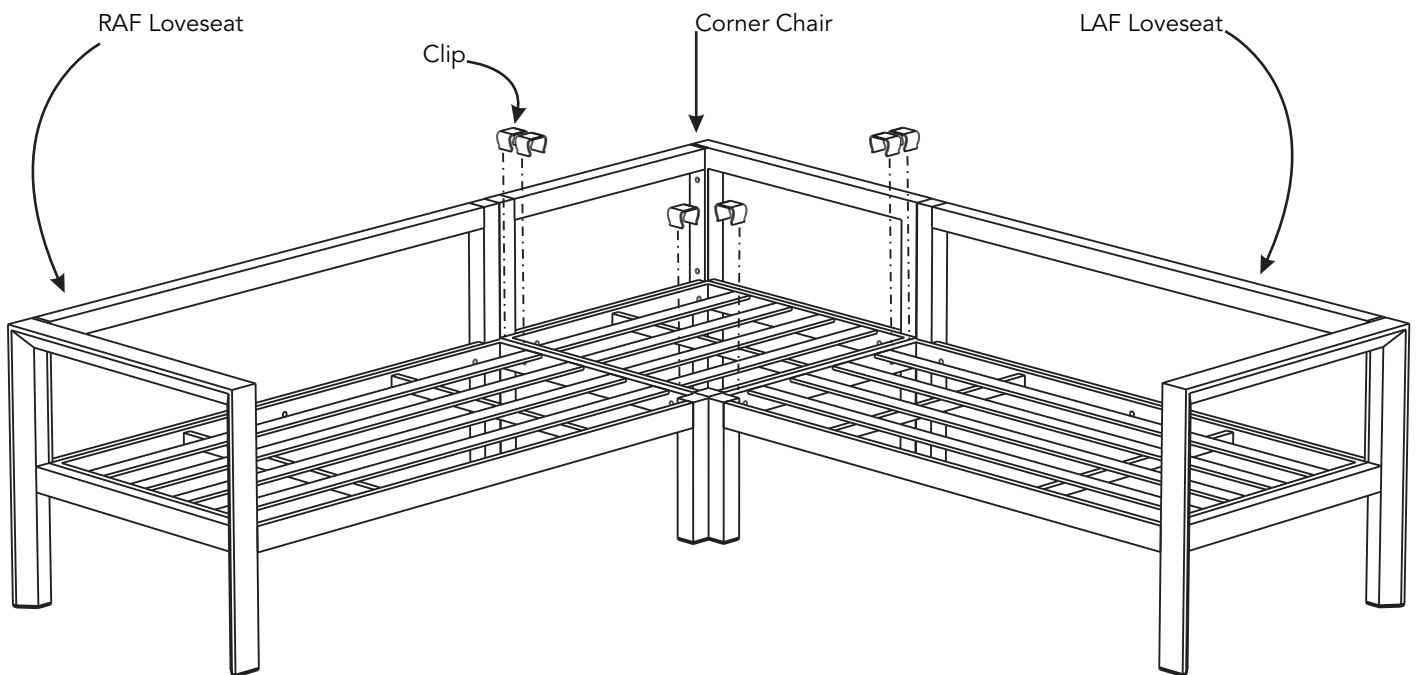

STEP 6

Attach RAF Loveseat and LAF Loveseat to Corner Chair with 6 pcs. of clips.

Hold Seat Frames of left unit and right unit together.

Ensure the legs straight and there is no gap.

Squeeze adjoining frames tightly together & hook one of the arms (of the clip) on the backside of the tube.

Spread the clip open by pushing it against and across the tubes so it captures both seat frames. (See Figures 3, 4 and 5)

Note : Do not use a tool to force the clips on

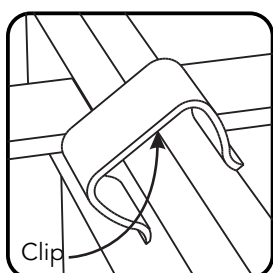

Figure 3

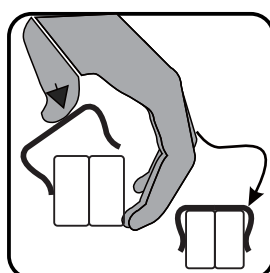

Figure 4

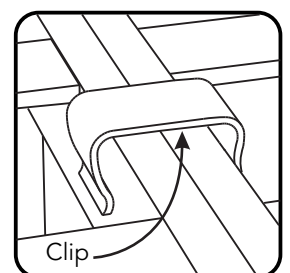
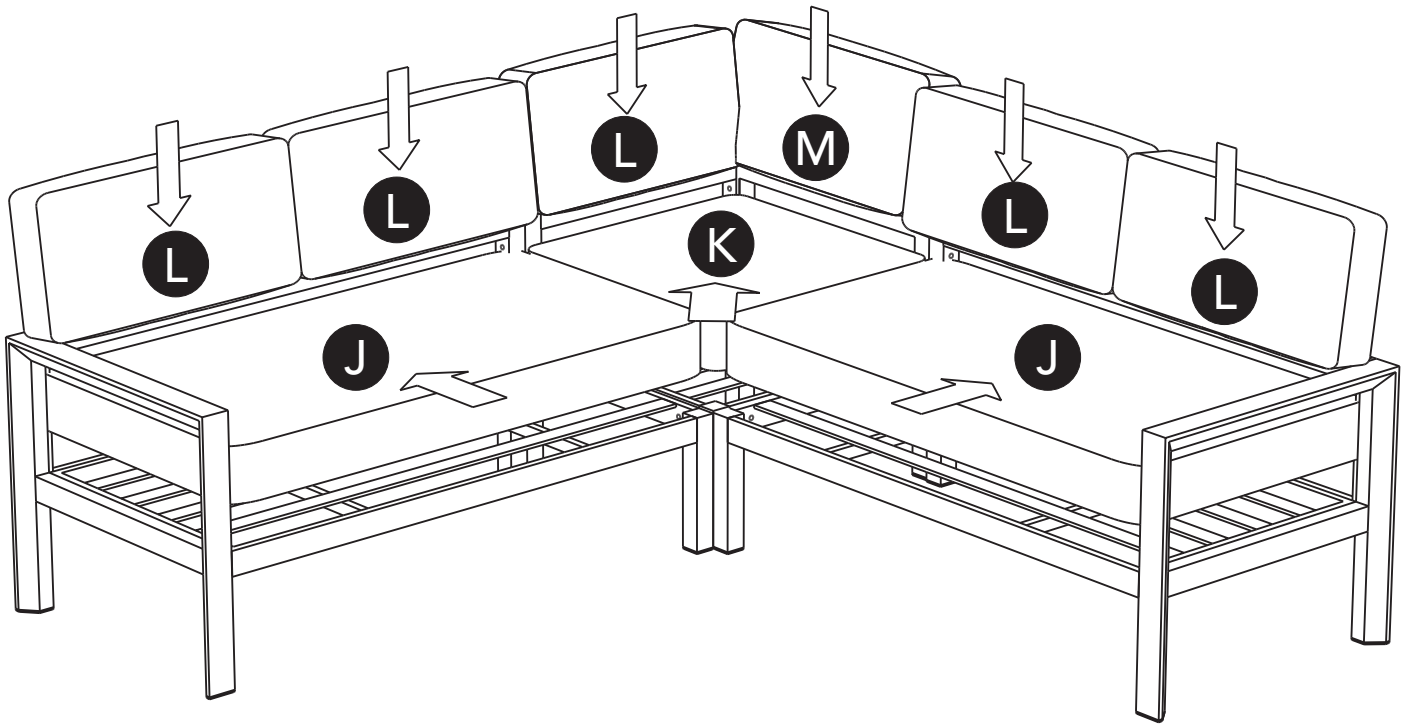

Figure 5



STEP 7

Slide Seat Cushions (J) and (K) into position.

Place Back Cushions (L) and (M) into position.

CARE INSTRUCTIONS

NEVER

allow liquids to remain on furniture.
Absorption causes parts to warp
and split and finishes to delaminate.

NEVER

use glass cleaners on
finished furniture. Ammonia
chemically attacks the finish.



Do not use power tools
above 8 volts to assemble.

**PREVENT
CRACKING**

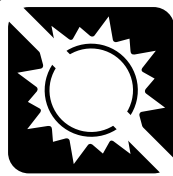

Do not place
in direct sunlight.

**PREVENT
FADING**



Do not write
directly on surface.

**PREVENT
MARKING**



Do not place hot
objects on surface.

**PREVENT
FINISH DAMAGE**

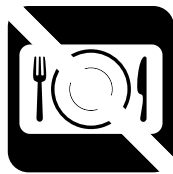

Do not use rubber
based placemats.

**PREVENT
DISCOLORING**



Do not use commercial
waxes and polishes.

**PREVENT
YELLOWING**

CLEAN

with a soft cloth moistened
in lukewarm soap and water.
Buff with a dry clean cloth.



We will provide replacements free of charge for missing or damaged parts within 1 year of purchase. Digital images of the defective parts may be required. If the product was not purchased from an authorized retailer.

We are under no obligation to provide replacement parts. Parts are not available for fully assembled items nor are parts available for sale. Replacements for missing or damaged parts may be requested via contact info below.