

# Emerson Mailbox System *Installation Instructions*

**ADDRESSES OF DISTINCTION**  
MAILBOXES + STREET SIGNS. INSTALLED.

**Tools Required:** phillips head screw driver, 7/16" wrench or pliers, and allen key.

## STEP 1

Place (2) 1/4"-20 x 1/2" Pan Head Bolts through the top of the Number Plate 8. Place number plate on top of the Mailbox 8 and place the bolts through the pre-drilled holes on top of the mailbox. See *Illustration A1*

*Illustration A1*

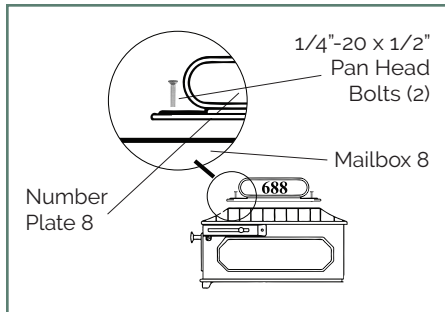

*Illustration A2*

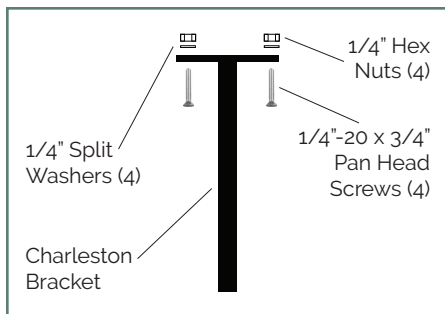

## STEP 2 (Fig 1)

Position the Charleston Bracket on the bottom of the mailbox. Insert (4) 1/4"-20 x 3/4" Pan Head Screws through the bottom of the Charleston Bracket into the pre-drilled holes on the Mailbox 8. Secure the Pan Head Screws using (4) 1/4" Split Washers and (4) 1/4" Hex Nuts. See *Illustration A2*

(Fig 1)

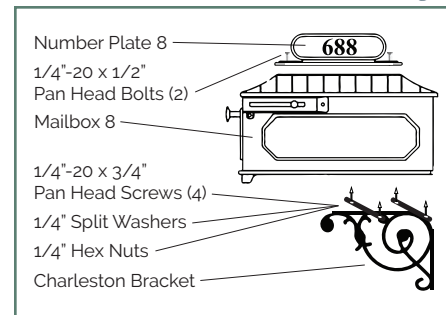

## STEP 3 (Fig 2)

Attach the mailbox and bracket assembly from Step 2 to the 2 1/2" Round Post using (2) 1/4" - 20 x 3" Hex Head Bolts.

## STEP 4 (Fig 2)

Finish the look of your mailbox by sliding the 2 1/2" Charleston Base onto bottom of the post. Insert the 2 1/2" Pineapple Finial on top of the post and secure with the (1) 1/4"-20 x 1/4" Set Screw. Secure the base with (3) 1/4"-20 x 3/8" Set Screws after the system is installed. Place the (1) Anti-Rotational Bolt near the bottom of the Post to secure in concrete. Your mailbox is ready to be installed in the ground.

(Fig 2)

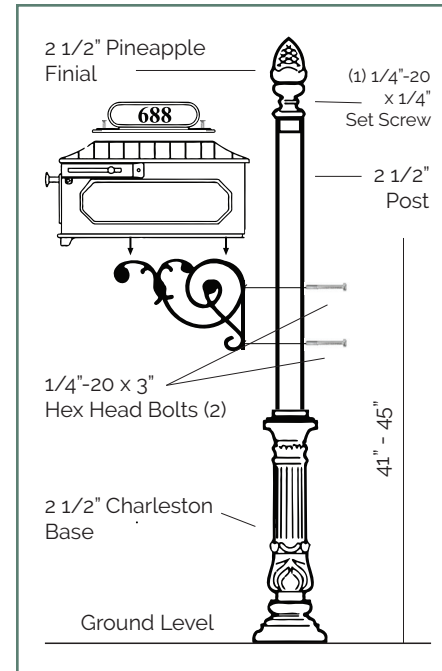

*Emerson Mailbox System*



## **YOUR MAILBOX PARTS**

2 1/2" Post  
2 1/2" Pineapple Finial  
2 1/2" Charleston Base  
Charleston Bracket

Number Plate 8  
Mailbox 8  
(1) 1/4 - 20 x 1/4" Set Screw  
(2) 1/4 - 20 x 3" Hex Head Bolts

(4) 1/4 - 20 x 3/4" Pan Head Screws  
(4) 1/4" Split Washers  
(4) 1/4 - 20 Hex Nuts  
(2) 1/4 - 20 x 1/2" Pan Head Bolts

(3) 1/4 - 20 x 3/8" Set Screws  
(1) Anti-Rotational Bolt

# SUPPORT + FAQs

For Installation Tips:  
[aodmailboxes.com/installvideo](https://aodmailboxes.com/installvideo)

If I have questions, who can help? Call us at **1-800-436-1647**  
or email us at [support@aodmailboxes.com](mailto:support@aodmailboxes.com).

## What's the story of your company?

Addresses of Distinction was founded by two brothers from Georgia over a decade ago. While shopping for a mailbox, they were surprised how difficult it was to find a high quality mailbox that could stand the test of time. This led them to create a line of mailboxes that created a long lasting, first impression. They make decisions based on one simple rule - Would they be proud selling the mailbox to their family or best friends?

## How do I care for my mailbox?

Occasionally your mailbox may need cleaning. We suggest washing it with a mild, non-abrasive soap using a soft cloth or brush. Make sure to thoroughly rinse all the soap off the mailbox. If you are using brass numbers, they may be cleaned with a brass cleaner such as Brasso.

## What if my mailbox is damaged at some future point?

All of our mailboxes are bolted together so parts can be easily replaced. Simply call the number on the inside of the door and our team will be happy to help you bring your mailbox back to life.

## Do you install with concrete?

All mailboxes installed by Addresses of Distinction are installed using concrete. We warranty all installations for a period of one year. When your mailbox is installed, please wait 24 hours before applying pressure to the post, as it takes some time for the concrete to fully cure.