

# ASSEMBLY INSTRUCTION

NO	PARTLIST	QTY
1	HEADBOARD	1PC
2	FOOTBOARD	1PC
3	LEG EXTENSION	2PCS
4	SIDE RAIL SUPPORT	1PC
5	SIDE RAIL	2PCS
6	SIDE RAIL	2PCS
7	LEG	2PCS
8	FINIALS	4PCS
9	CENTER LEG	1PC
10	SUPPORT LEG WITH ADJUSTABLE FEET	8PCS
11	CENTER SUPPORT	4PCS
12	SLAT	2SETS
ITEM	HARDWARE	QTY
A	JCBB SCREW M8 x 20MM	10PCS
B	JCBC SCREW M6 x 16MM	8PCS
C	JCBC SCREW M6 x 25MM	3PCS
D	SCREW M4 x 32MM	8PCS
E	L - KEY M4 x 65MM	1PC
F	L - KEY M5 x 65MM	1PC

STEP 1

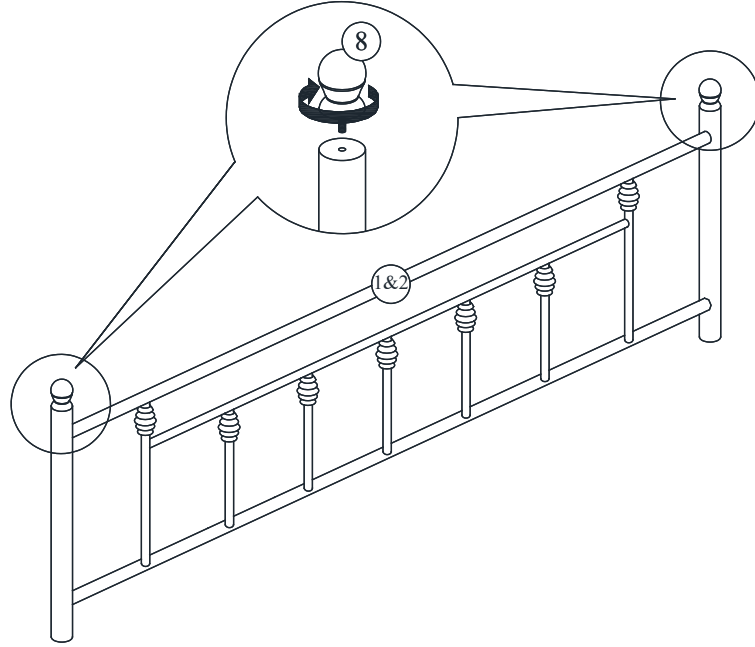

STEP 2

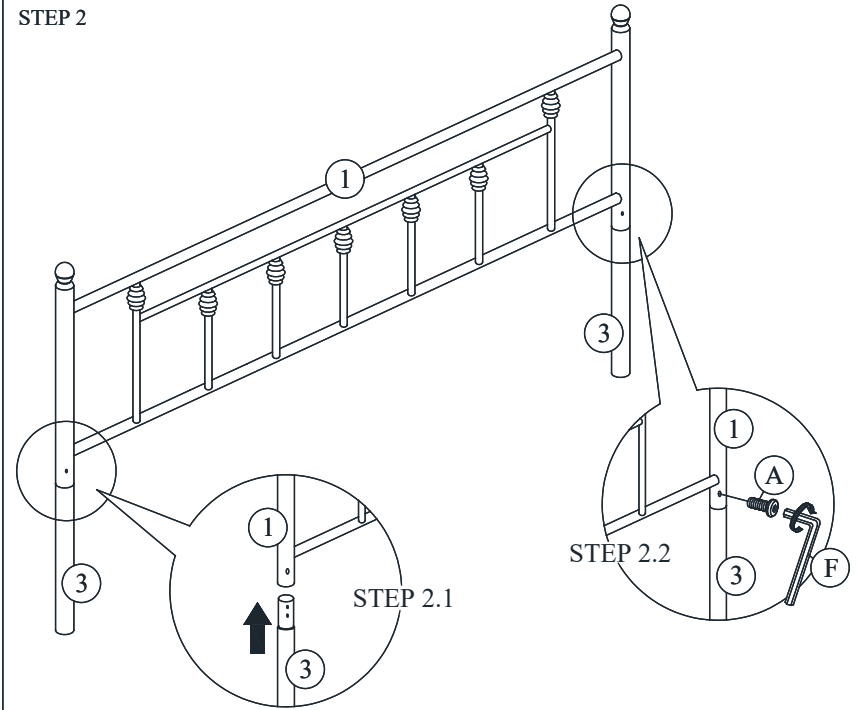

STEP 3

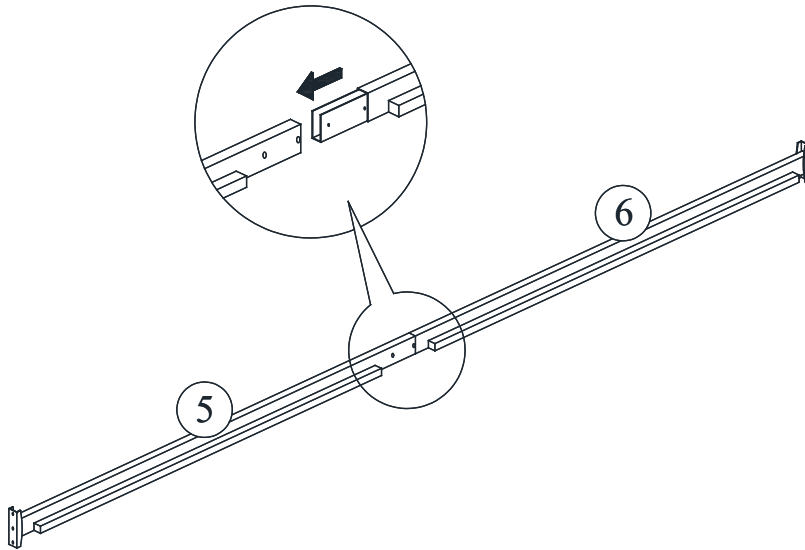

STEP 4

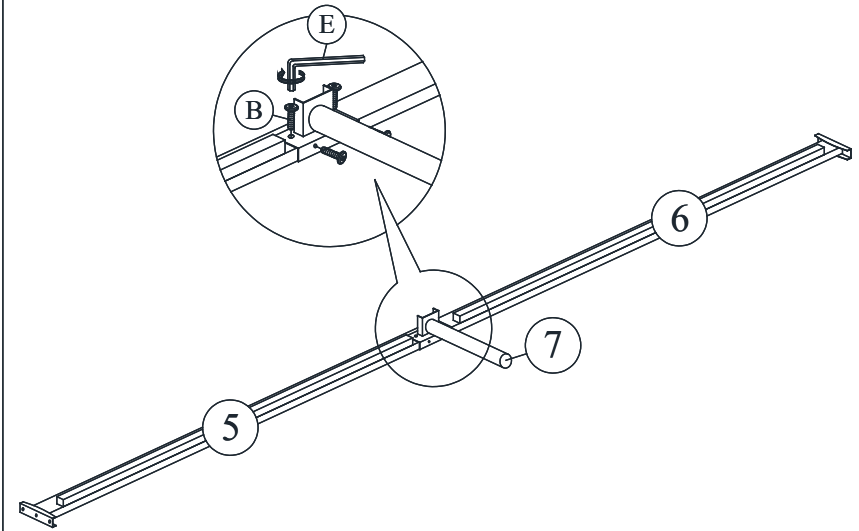

# ASSEMBLY INSTRUCTION

STEP 4

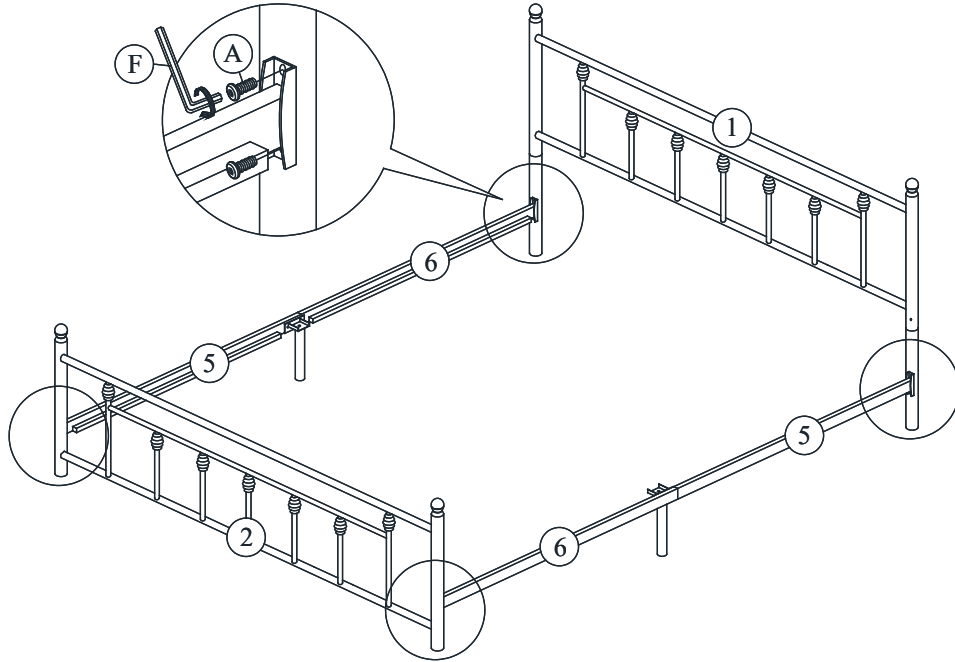

STEP 5

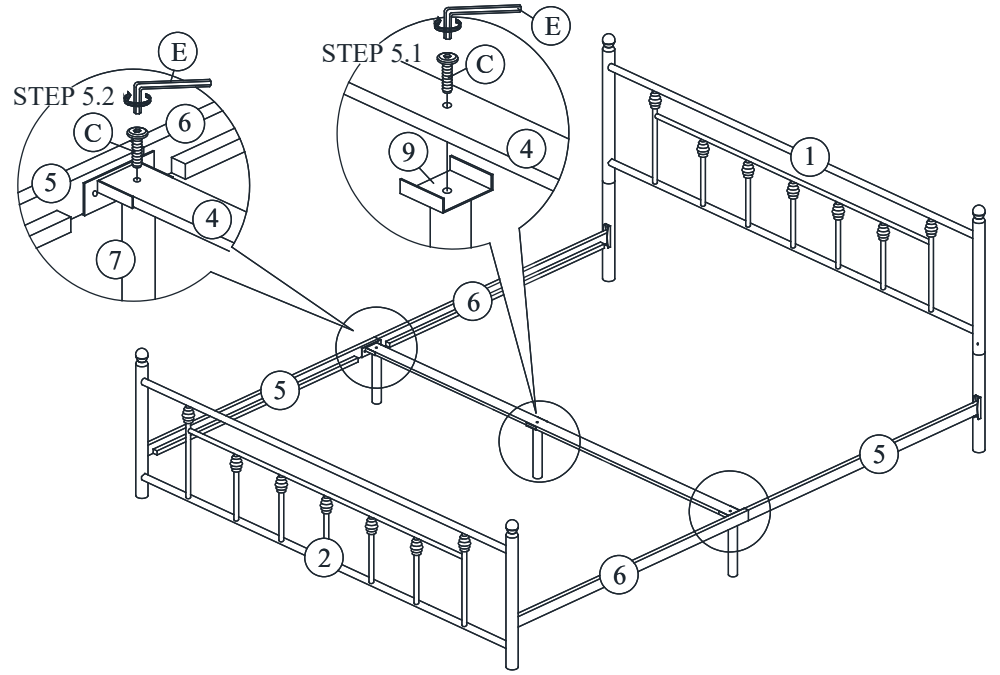

STEP 6

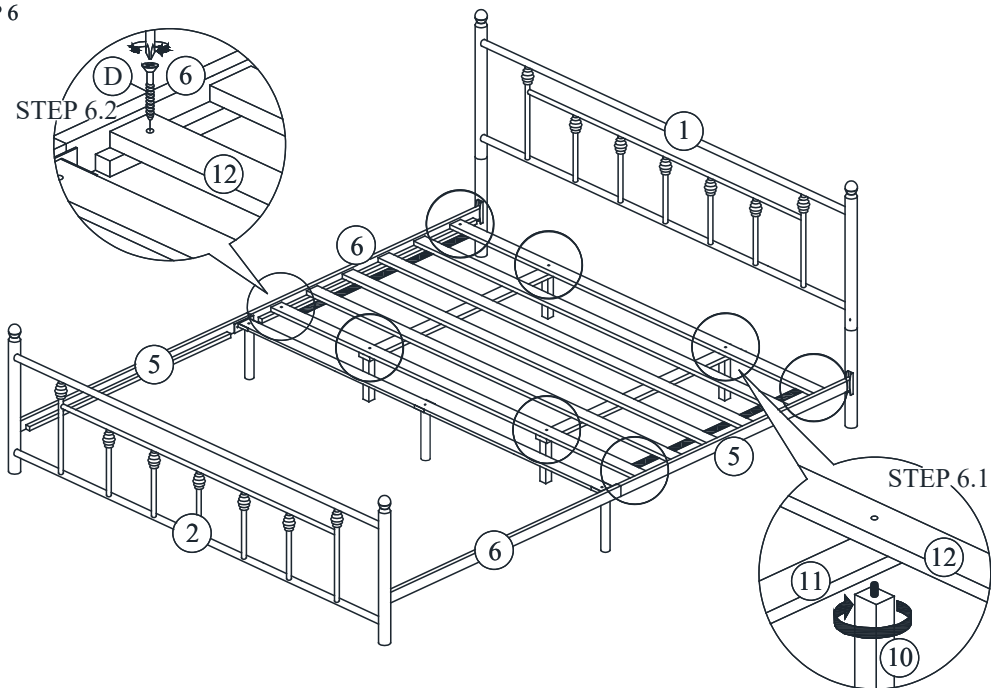

STEP 7

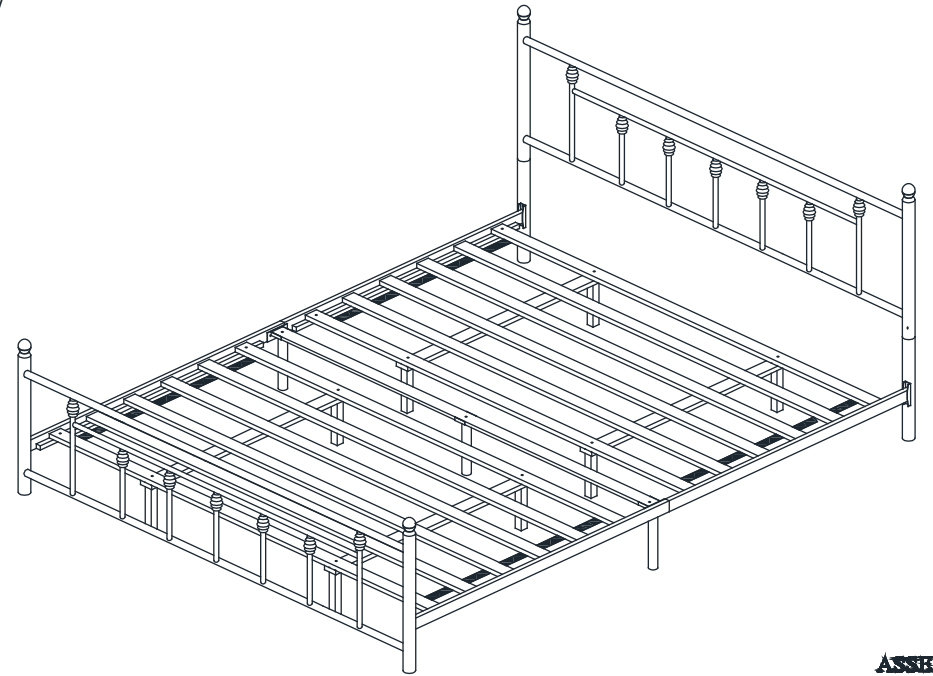

ASSEMBLY  
COMPLETED