



**Vestil Manufacturing Company**  
 2999 North Wayne Street, P.O. Box 507, Angola, IN 46703  
 Telephone: (260) 665-7586 -or- Toll Free (800) 348-0868  
 Fax: (260) 665-1339  
[www.vestil.com](http://www.vestil.com)      [info@vestil.com](mailto:info@vestil.com)

## CL-Series Cargo Bars



### RECEIVING INSTRUCTIONS

After delivery, remove the packaging from the product. Inspect the product closely to determine whether it sustained damage during transport. If damage is discovered, record a complete description of it on the bill of lading. If the product is undamaged, discard the packaging.

**NOTE:** The end-user is solely responsible for confirming that product design, use, and maintenance comply with laws, regulations, codes, and mandatory standards applied where the product is used.

### TECHNICAL SERVICE & REPLACEMENT PARTS

For answers to questions not addressed in these instructions or to order replacement parts, labels, and accessories, contact our Technical Service and Parts Department at (260) 665-7586. You can also reach the department online at <https://www.vestil.com/page-parts-request.php>.

### ELECTRONIC COPIES OF INSTRUCTION MANUALS

Additional copies of this instruction manual can be downloaded from <https://www.vestil.com/page-manuals.php>.

Table of Contents		Page
Introduction.....		2
Specifications.....		2
Standards and Regulations.....		3
Signal Words.....		3
Safety Instructions.....		4
Record of Satisfactory Condition.....		4
Cargo Bar Components.....		5
Using the Cargo Bar.....		6 - 7
Inspecting and Maintaining the Cargo Bar.....		7
CL-16 View and Bill of Materials.....		8
CL-17 View and Bill of Materials.....		9
Labels.....		10
Limited Warranty.....		11

## INTRODUCTION

This manual provides instructions for the safe use and maintenance of Vestil CL-16 and CL-17 cargo bars. These cargo bars are designed to secure cargo in trailers and prevent shifting during transport. Users are responsible for ensuring compliance with all applicable federal, state, and local regulations, including those outlined in the [STANDARDS AND REGULATIONS](#) section on p. 3. For additional information or technical support, contact Vestil Manufacturing at (260) 665-7586 or [info@vestil.com](mailto:info@vestil.com).

## SPECIFICATIONS

For the most up-to-date specifications, technical drawings, and additional information on the CL-16 and CL-17 cargo bars, please visit the Vestil Manufacturing Company webpage for Cargo Bars at <https://www.vestil.com/product.php?FID=72> or contact Vestil at (260) 665-7586. The following table outlines the specifications for the models covered by this instruction manual.

Model	Description	Material	Square Tubing Size	Tubing Thickness	End Plate Size	Service Range	Weight
CL-16	Galvanized, One-Piece Cargo Bar	Galvanized Steel Frame; Vulcanized Rubber Foot Pads	1-1/2 in.	14 gauge steel	4 x 4 in.	87-119 in.	18.7 lbs
CL-17	Steel, Two-Piece Folding Cargo Bar	Galvanized Steel Frame; Vulcanized Rubber Foot Pads	1-1/2 in.	14 gauge steel	4 x 4 in.	88-116 in.	19.0 lbs

**Note:** Dimension tolerance is ± 1/4 in. Weights do not include packaging.

For detailed technical drawings, please refer to the following links:

- [CL-16 View and Bill of Materials](#)
- [CL-17 View and Bill of Materials](#)

## STANDARDS AND REGULATIONS

The use of cargo bars for securing cargo in commercial motor vehicles is subject to regulations set forth by the Federal Motor Carrier Safety Administration (FMCSA) under 49 CFR Part 393, Subpart I - Protection Against Shifting and Falling Cargo. These regulations establish minimum standards for cargo securement devices and systems to ensure the safe transportation of cargo on public highways.





Specifically, cargo bars, also known as shoring bars, must be in proper working order with no damaged or weakened components that could adversely affect their performance, as per [49 CFR § 393.104](#). The securement system, which may include cargo bars, must prevent the cargo from shifting or falling from the vehicle, meeting the performance criteria outlined in [49 CFR § 393.102](#).

For detailed information, users can access the FMCSA regulations at FMCSA Cargo Securement Rules or the Electronic Code of Federal Regulations at [49 CFR Part 393](#). Additionally, industry best practices for cargo securement can be found in [ASTM D5728 - Standard Practices for Securement of Cargo in Intermodal and Unimodal Surface Transport](#), available for purchase from ASTM International.

It is the responsibility of the user to ensure that the cargo bars are used in compliance with all applicable federal, state, and local regulations. For non-commercial use, following these standards is recommended to ensure safety.

## SIGNAL WORDS

This manual uses SIGNAL WORDS to indicate the likelihood of personal injuries, as well as the probable seriousness of those injuries, if the product is misused. Other signal words call attention to uses of the product likely cause property damage. The following signal words might appear in this manual.

	<b>Identifies a hazardous situation which, if not avoided, <u>WILL</u> result in DEATH or SERIOUS INJURY. Use of this signal word is limited to the most extreme situations.</b>
	<b>Identifies a hazardous situation which, if not avoided, COULD result in DEATH or SERIOUS INJURY.</b>
	<b>Indicates a hazardous situation which, if not avoided, COULD result in MINOR or MODERATE injury.</b>
	<b>Identifies practices likely to result in product/property damage, such as operation that might damage the crane.</b>

## SAFETY INSTRUCTIONS

Exercise sound judgment when assembling, using, inspecting, and maintaining this cargo bar. **Keep a copy of this manual with the device, if possible, at all times. Otherwise, it should be kept in a location known by, and accessible to, all persons who might use it.**

### WARNING

- Read and understand this manual before using the cargo bar.
- Inspect the cargo bar before each use. Do not use if damaged or if parts are loose.
- Ensure the cargo bar is properly adjusted and solidly engages the walls of your trailer before transporting the trailer.
- Do not exceed the capacity of the cargo bar with heavy loads.
- Be aware of dynamic loading; sudden stops or turns can increase effective load weight.
- Use only in designed vehicles, such as trailers with adequate wall strength.
- Keep the cargo bar clean and free of debris.
- Store properly when not in use.
- Follow all applicable regulations for securing cargo, e.g. 49 CFR Part 393 and relevant state and local requirements.
- Do not use for top-heavy or stacked loads; cargo bars are designed to prevent horizontal movement, not to support vertical loads.
- Ensure the rubber foot pads are clean and in good condition which is necessary to ensure adequate grip.
- Position the cargo bar at an appropriate height to effectively secure the cargo.
- For model CL-17, ensure the bar is extended and properly unfolded before use.
- Do not use the cargo bar for any purpose other than securing cargo.
- Keep hands and fingers clear of moving parts when adjusting the cargo bar.
- Maintain labels for model identification and safety information.
- Do not modify the cargo bar without manufacturer approval. Unapproved modifications may void the [LIMITED WARRANTY](#) and compromise safety.
- Do not remove or obscure any labels or markings on the cargo bar.

## RECORD OF SATISFACTORY CONDITION

After removing the cargo bar from its packaging and before using the cargo bar for the first time, thoroughly inspect it to ensure it is in satisfactory condition. Document this condition by taking photographs/videos and making notes of the cargo bar's state. Include close-range photographs of the main bar, both rubber pads (be sure to image the entire face of each pad), ratchet mechanism, all pins and fasteners, formed coupler (CL-17), and all labels or markings applied to it. Collect all writings and photos/videos in a file. This file is a record of the cargo bar in satisfactory condition. The record serves as a baseline for future inspections to determine if the cargo bar remains in satisfactory condition. Do not use the cargo bar unless it is in satisfactory condition.

# CARGO BAR COMPONENTS

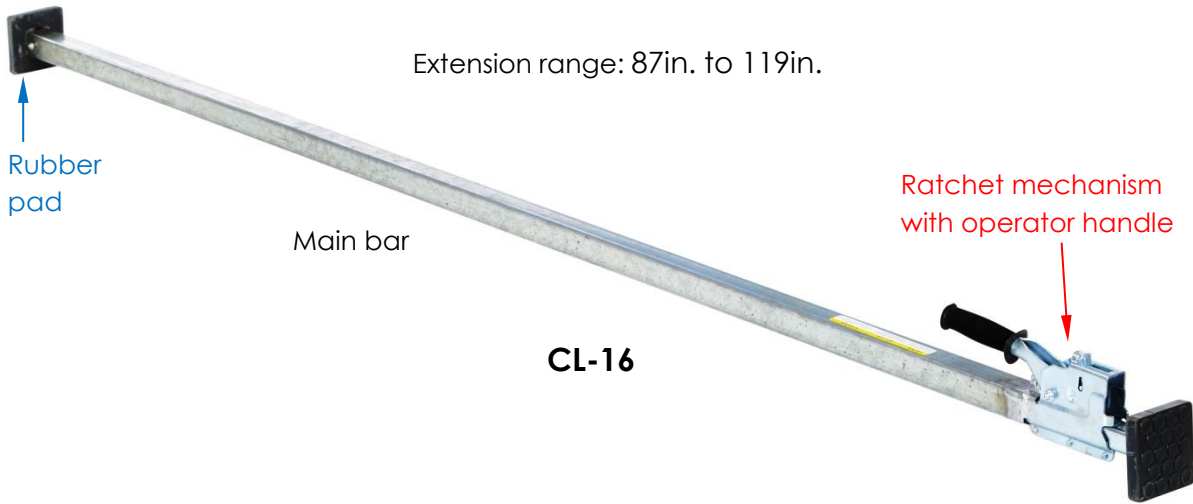

- **Main Bar:** Constructed of 1-1/2 in. galvanized square steel tubing for strength and durability.
- **End Plates:** Articulating steel plates with vulcanized rubber pads for secure gripping.
- **Locking Mechanism:** Ratcheting action allows the cargo bar to solidly engage the side walls of a trailer. Use of a ratchet system prevents vibration loosening.
- **Two-Piece Design:** Folding design provides compact configuration for storing the cargo bar when not in use.

# USING THE CARGO BAR

NOTE: A second person can make cargo bar installation significantly easier.

1. **Determine Placement:** Identify the optimal location in the trailer to secure cargo effectively.
2. **Put CL-17 model Cargo Bar into Use Configuration (not applicable to model CL-16):** Model CL-17 can be folded when not in use to reduce the space necessary for it to be stored. To unfold CB-17, remove the **wing-head bolt** from the third bolt hole of the formed coupler.

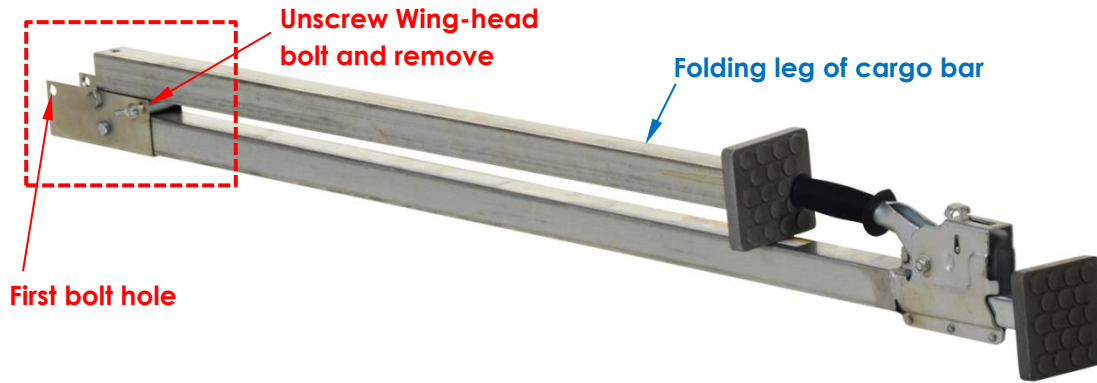

Unfold the **folding leg** of the cargo bar; then install the wing-head bolt into the first bolt hole. Tighten by turning the bolt clockwise until the connection is snug.



**Wing-head bolt installed in first bolt hole**

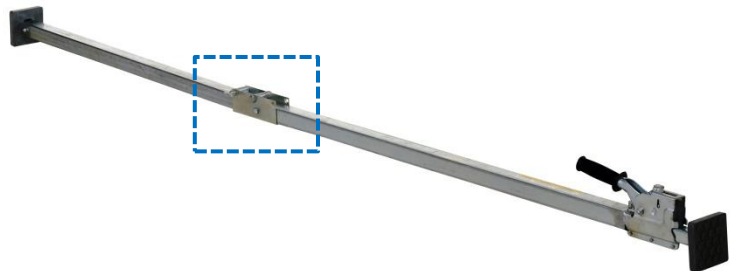

3. **Position the Bar:** Orient the cargo bar with the ratchet handle on top. Place the cargo bar between trailer walls. If more than 1 cargo bar will be used, set the lowest bar first. Applying a cargo bar at floor level is an effective method for restraining pallets/skids.

4. **Adjust Length:** Set the cargo bar on the floor of the trailer. Adjust the length of the bar to be just a little bit shorter than the trailer width. To do this, put the **Direction Selector Switch** in the “**Extend**” Position. The ratchet mechanism can be operated in either of 2 modes: Extend or Retract. In **EXTEND** mode, moving the operator handle back-and-forth causes the cargo bar to extend (lengthen). Push the selector switch forward to put the ratchet in **RETRACT** mode. In **RETRACT** mode, the cargo bar shortens as the operator moves the handle. Retract mode is used to release the cargo bar from the trailer walls. In the diagram to the right, the switch is shown in **EXTEND** position.

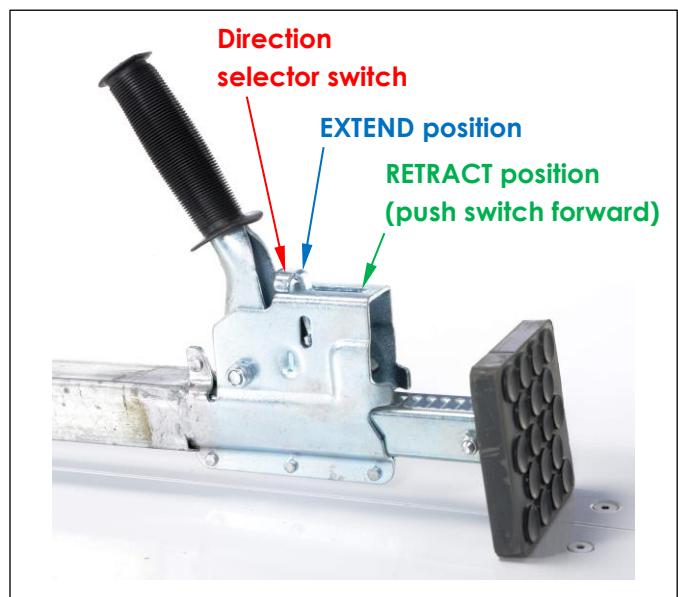

5. **Deploy the Cargo Bar:** Use the (ratchet) operator lever to extend the cargo bar until the rubber pads solidly engage both trailer walls. Be careful not to overextend the bar and cause damage to the trailer.
6. **Verify Stability:** Ensure the cargo bar solidly engages the trailer walls. The rubber feet should not move/slide if slight pressure is applied to the cargo bar.
7. **Apply additional cargo bars as needed to adequately restrain your cargo:** Bars can be deployed horizontally (as shown in the photo) as well as vertically. Applying a cargo bar at floor level is an effective method for restraining pallets/skids.
8. **Removal:** Release the cargo bar by putting the direction selector switch in the **RETRACT** position. Apply slight pressure to one of the rubber pads while operating the lever, i.e. press the pad away from the trailer wall. Without applying pressure, the ratcheting mechanism will not retract the bar.
9. **Return the cargo Bar to its Storage Location:** If you are using a CL-17 bar, fold the bar for easy storage when not in use. Fold the bar by reversing the process described in Step 2.



## INSPECTING AND MAINTAINING THE CARGO BAR

Inspections and repairs should only be performed by qualified persons. Compare the results of each inspection to the [RECORD OF SATISFACTORY CONDITION](#). Do not continue to use the cargo bar unless all parts are in satisfactory condition. Replace parts that are not in satisfactory condition before returning the unit to regular service. Never make temporary repairs of damaged or missing parts. Only use manufacturer-approved replacement parts to restore the unit to satisfactory condition. If you have any questions about the condition of your cargo bar, contact the [TECHNICAL SERVICE](#) department at (260) 665-7586.

- **Regular Inspection:** Visually inspect the cargo bar for wear, damage, or corrosion before each use. Compare the current condition to the [RECORD OF SATISFACTORY CONDITION](#) to identify any changes or damage.
  - NOTE: as required by [49 CFR § 393.104\(b\)](#) states: "All tiedowns, cargo securement systems, parts and components used to secure cargo must be in proper working order when used to perform that function with no damaged or weakened components, such as, but not limited to, cracks or cuts that will adversely affect their performance for cargo securement purposes, including reducing the working load limit."
- **Rubber Pads:** Inspect for significant wear, cuts, tears, or other damage that might affect the pads ability to resist movement when solidly pressed against a trailer wall. Replace a pad if necessary for it to be able to maintain grip.
- **Ratchet Mechanism:** Ensure it functions properly in both directions (extend and retract; see [USING THE CARGO BAR](#) on p. 6-7). Remove debris from the surfaces of the cargo bar that might interfere with ratchet operation.
- **Cleaning:** Remove dirt or debris from the surfaces of the cargo bar.
- **Labels and Markings:** Check that all labels and markings are in place, easily readable from a reasonable distance, and undamaged.
- **Replacement Parts and Labels:** Use only manufacturer-approved replacement parts. Contact Vestil at (260) 665-7586 or [info@vestil.com](mailto:info@vestil.com) for assistance.
- **Store Properly:** Store the cargo bar in a dry, protected area when not in use to prevent damage from weather or environmental factors.

# CL-16 VIEW AND BILL OF MATERIALS

## 44-001-045

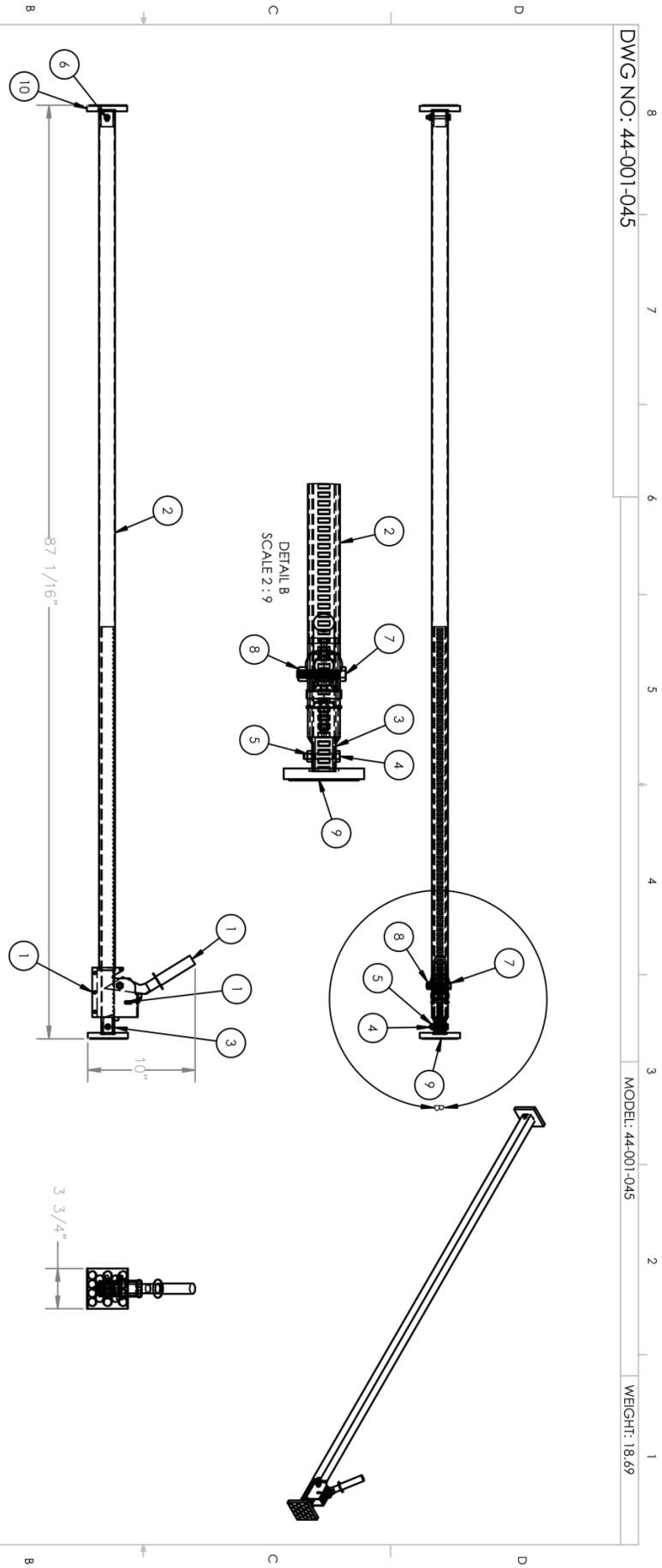

ITEM NO.	PART NUMBER	DESCRIPTION	QTY.
1	44-001-045-G	HANDLE GRIP	1
2	44-001-045-B	FRAME, TUBE	1
3	44-001-045-H	JACK	1
4	11009	HEX BOLT, GRADE A, ZINC PLATED, 1/4"-20 X 1-1/2"	1
5	36102	HEX NUT, GRADE A, ZINC PLATED, 1/4-20	2
6	11011	HEX BOLT, GRADE A, ZINC PLATED, 1/4"-20 X 2"	1
7	11111	HEX BOLT, GRADE A, ZINC PLATED, 3/8" - 16 X 2"	1
8	37024	NYLON INSERT LOCK NUT, GRADE 2, ZINC FINISH, 3/8"-16	1
9	23-037-026	CARGO BAR PAD, Ø13/16" POST	1
10	23-037-027	CARGO BAR PAD, Ø1 1/8" POST	1



**PROPERTY AND COMMERCIAL**  
DRAWING IS THE SOLE PROPERTY OF  
VESTIL MANUFACTURING CO. ANY  
REPRODUCTION OR TRANSMISSION OF  
THIS DRAWING WITHOUT THE WRITTEN PERMISSION OF  
VESTIL MANUFACTURING CO. IS  
PROHIBITED.

**UNLESS OTHERWISE SPECIFIED:**

REMOVE ALL BURRS AND SHARP EDGES	
DIMENSIONS ARE IN INCHES	
CONCENTRIC	±.006 TIR
ANGLES	±.060 TIR
DECIMALS	XXXX ±.005
FRACTIONS	XX ±.005
TOLERANCES	±.005
COMMENTS:	

DO NOT SCALE DRAWING

**Vestil Manufacturing Co.**

DESCRIPTION: **FINAL ASSEMBLY W/O SHIPPING**

MODEL NO: CL-16

DRAWN BY: [ ] DATE: 07/2025

MATL: AS LISTED

DWG. NO: **44-001-045**

SCALE: BARGE SIZE **B**

# CL-17 VIEW AND BILL OF MATERIALS

## 44-001-037

DWG NO.: 44-001-037

MODEL: 44-001-037

WEIGHT: 19.02

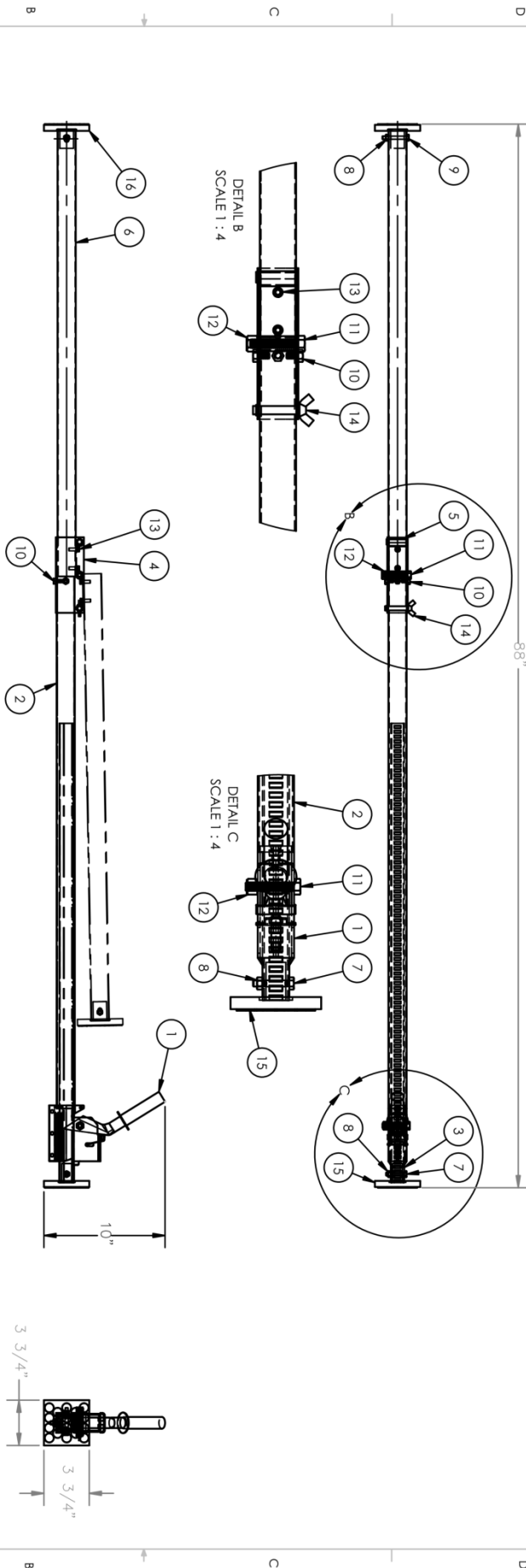

ITEM NO.	PART NUMBER	DESCRIPTION	QTY.
1	44-001-037-G	HANDLE GRIP	1
2	44-001-037-B	FRAME TUBE	1
3	44-001-037-H	JACK	1
4	44-001-037-D	FORMED CHANNEL BRACKET	1
5	44-001-037-F	RECTANGULAR TUBE	1
6	44-001-037-A	HEX BOLT, GRADE A, ZINC PLATED, 1/4"-20 X 1-1/2"	1
7	11009	HEX BOLT, GRADE A, ZINC PLATED, 1/4"-20	2
8	36102	HEX BOLT, GRADE A, ZINC PLATED, 1/4"-20 X 2"	1
9	11011	HEX BOLT, GRADE A, ZINC PLATED, 1/4"-20 X 1/2"	3
10	11111	HEX BOLT, GRADE A, ZINC PLATED, 3/8" - 16 X 2"	2
11	37024	NYLON INSERT LOCK NUT, GRADE 2, ZINC FINISH, 3/8"-16	2
12	39566	SHCS, METRIC UTILITY GRADE M6-1.0 X 1.6MM	2
13	44-001-037-I	BOLT, STAMPED WING HEAD	1
14	23-037-026	CARGO BAR PAD, Ø1 3/16" POST	1
15	23-037-027	CARGO BAR PAD, Ø1 1/8" POST	1
16			1



**vestil**  
MANUFACTURING CO.

THE INFORMATION CONTAINED IN THIS DRAWING IS THE SOLE PROPERTY OF VESTIL MANUFACTURING CO. ANY REPRODUCTION OR TRANSMISSION OF THIS DRAWING WITHOUT THE WRITTEN PERMISSION OF VESTIL MANUFACTURING CO. IS PROHIBITED.

**UNLESS OTHERWISE SPECIFIED:**

REMOVE ALL BURS AND SHARP EDGES

DIMENSIONS ARE IN INCHES

CONCENTRIC .006 IN

ANGLES 3:0' 3:05

DECIMALS ±.005

FRACTIONS ±.005

TOLERANCES MATCH

WELDMENT

COMMENTS:

DESCRIPTION: **Vestil Manufacturing Co. FINAL ASSEMBLY W/O SHIPPING**

MODEL NO: CL-17

DRAWN BY: DATE: 7/8/2014

MAT'L: AS LISTED

DWG. NO. **44-001-037**

SCALE: PAGE: 1 OF 1

SIZE: **B**

# LABELING DIAGRAM

Each cargo bar is labeled as shown in the diagram. However, Vestil continually evaluates the adequacy of the content of its labels. Consequently, label content and location are subject to change and your product might not be labeled exactly as shown. Compare the diagram below to your RECORD OF SATISFACTORY CONDITION. If there are any differences between actual labeling and this diagram, contact TECHNICAL SERVICE.

Replace labels that are damaged, missing, or not easily readable (e.g. faded). To order replacement labels or to inquire whether your unit is properly labeled, contact the technical service and parts department online at <https://www.vestil.com/page-parts-request.php> or by calling (260) 665-7586 and asking for the Parts Department.

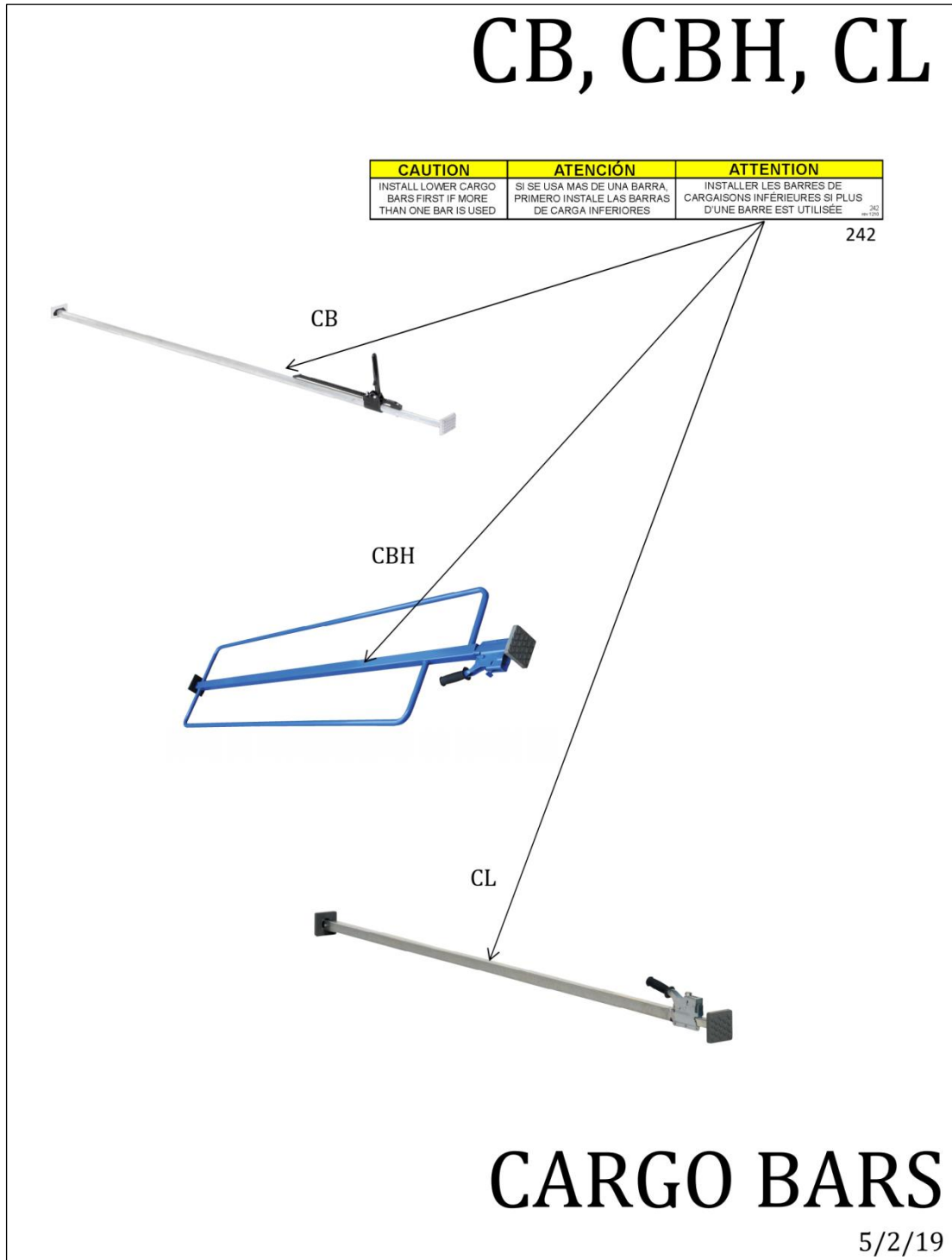



## LIMITED WARRANTY

Vestil Manufacturing Company ("Vestil") warrants HM-B series trailer dollies to be free of defects in material and workmanship during the warranty period. Our warranty obligation is to provide a replacement for a defective, original part covered by the warranty after we receive a proper request from the Warrantee (you) for warranty service.

### Who may request service?

Only a warrantee may request service. You are a warrantee if you purchased the product from Vestil or from an authorized distributor AND Vestil has been fully paid.

### Definition of "original part"?

An original part is a part used to make the product as shipped to the Warrantee.

### What is a "proper request"?

A request for warranty service is proper if Vestil receives: 1) a photocopy of the Customer Invoice that displays the shipping date; AND 2) a written request for warranty service including your name and phone number. Send requests by one of the following methods:

<u>US Mail</u>	<u>Fax</u>	<u>Email</u>
Vestil Manufacturing Company	(260) 665-1339	<a href="mailto:info@vestil.com">info@vestil.com</a>
2999 North Wayne Street, PO Box 507	<u>Phone</u>	Enter "Warranty service request" in subject field.
Angola, IN 46703	(260) 665-7586	

In the written request, list the parts believed to be defective and include the address where replacements should be delivered. After Vestil receives your request for warranty service, an authorized representative will contact you to determine whether your claim is covered by the warranty. Before providing warranty service, Vestil will require you to send the entire product, or just the defective part (or parts), to its facility in Angola, IN.

### What is covered under the warranty?

The warranty covers defects in the following original, dynamic parts: motors, hydraulic pumps, motor controllers, and cylinders. It also covers defects in original parts that wear under normal usage conditions ("wearing parts"), such as bearings, hoses, wheels, seals, brushes, and batteries.

### How long is the warranty period?

The warranty period for original dynamic components is 30 days. For wearing parts, the warranty period is 30 days. Both warranty periods begin on the date Vestil ships the product to the Warrantee. If the product was purchased from an authorized distributor, the periods begin when the distributor ships the product. Vestil may, at its sole discretion, extend a warranty period for products shipped from authorized distributors by up to 30 days to account for shipping time.

### If a defective part is covered by the warranty, what will Vestil do to correct the problem?

Vestil will provide an appropriate replacement for any covered part. An authorized representative of Vestil will contact you to discuss your claim.

### What is not covered by the warranty?

The Warrantee (you) are responsible for paying labor costs and freight costs to return the product to Vestil for warranty service.

### Events that automatically void this Limited Warranty.

- Misuse;
- Negligent assembly, installation, operation or repair;
- Installation/use in corrosive environments;
- Inadequate or improper maintenance;
- Damage sustained during shipping;
- Collisions or other accidents that damage the product;
- Unauthorized modifications: Do not modify the product IN ANY WAY without first receiving written authorization from Vestil.

### Do any other warranties apply to the product?

Vestil Manufacturing Co. makes no other express warranties. All implied warranties are disclaimed to the extent allowed by law. Any implied warranty not disclaimed is limited in scope to the terms of this Limited Warranty. Vestil makes no warranty or representation that this product complies with any state or local design, performance, or safety code or standard. Noncompliance with any such code or standard is not a defect in material or workmanship.