

Thank you for purchasing. We hope you get years of enjoyment from your new bed. The unique brushing process highlights the woods natural grain. All our wood is planta on grown. No two pieces of wood are the same, enjoy the natural beauty of wood, every piece of wood has unique grain and color and knots, these differences in texture and color create the look only solid wood provides.

The success or failure of a product sold on the internet is a direct reflection of positive or negative reviews. We would be grateful if you could post a positive review and help this products success, thank you for your help.

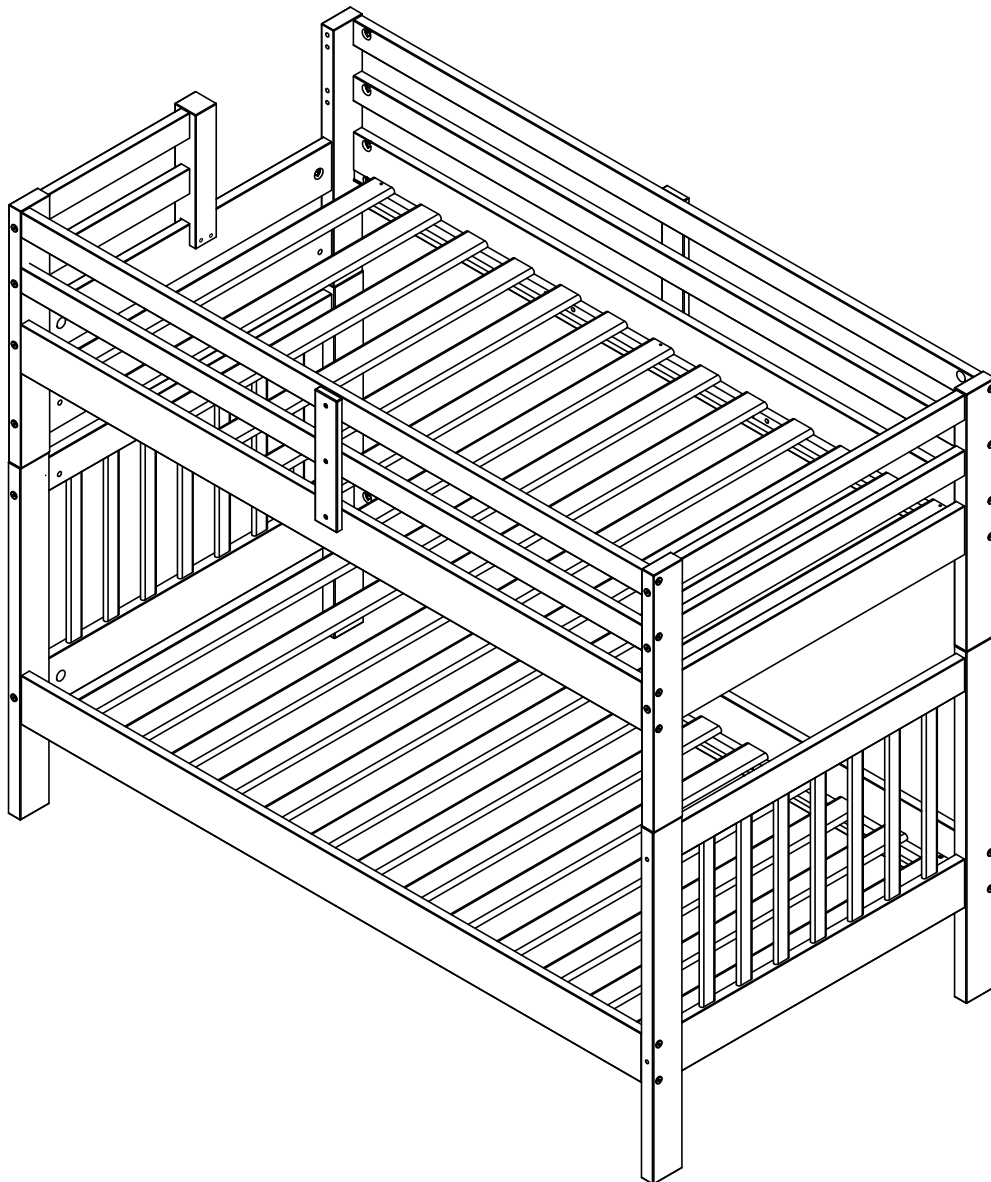



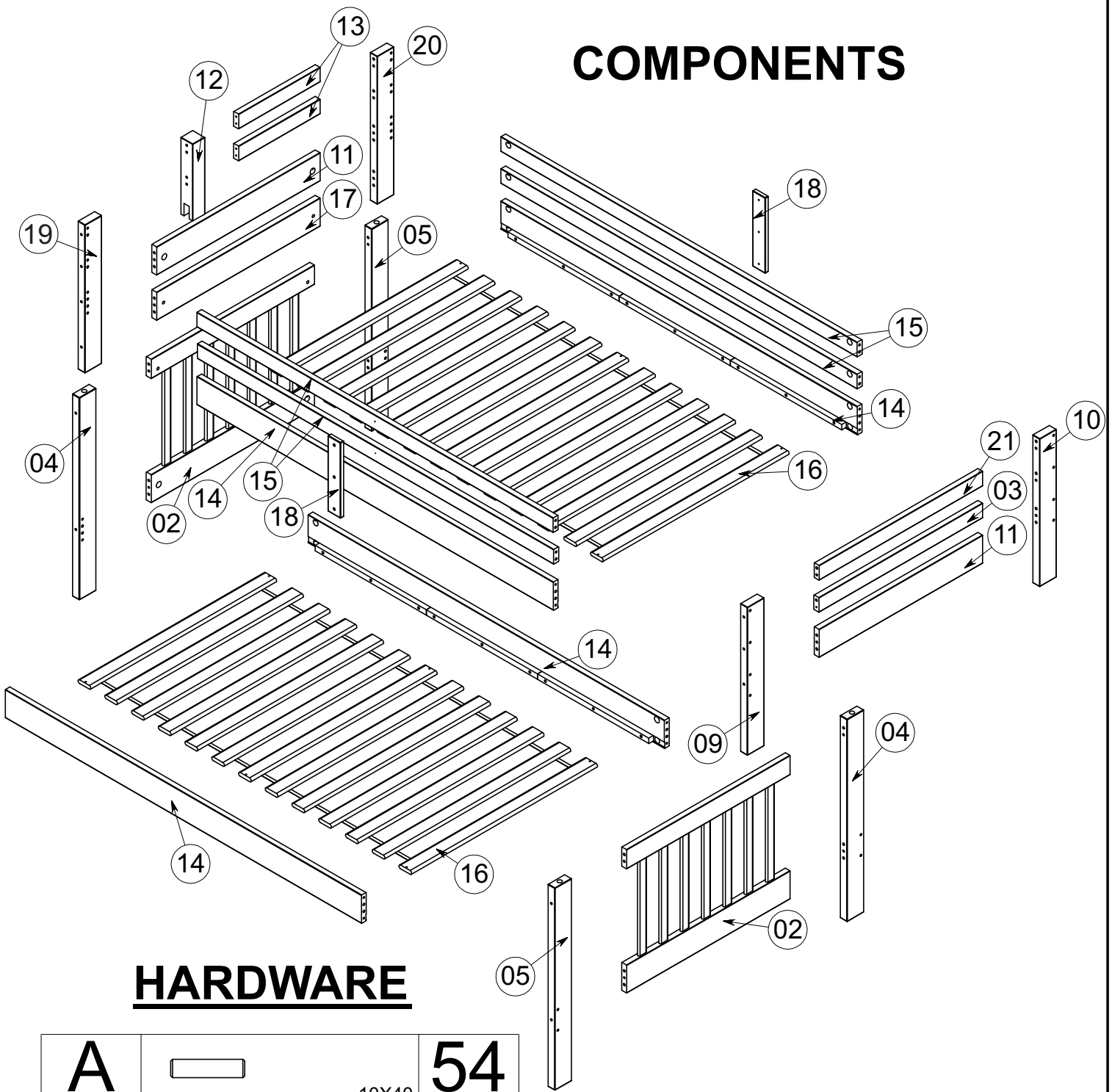

BUNK BED



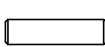

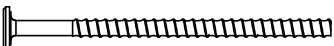
COMPONENTS

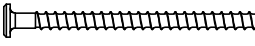

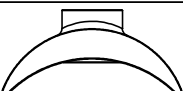
HARDWARE

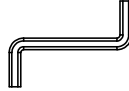
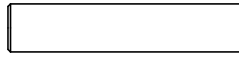
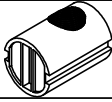
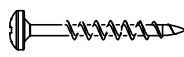
A	 10X40	54
B	 (17) - 1/4X130	16
C	 (17) - 7X130	04
D	 (17) - 1/4X80	24
E	 (17) - 7X100	04
F	 CC 4X35	14
G		32

H		02
I	 19X90	04
J	 19X11	08
K	 CP 4X30	06
L	 (17) 3/16X12	04
M	 3/16X78	02

STEP 1

REMOVE PACKING BOARDS

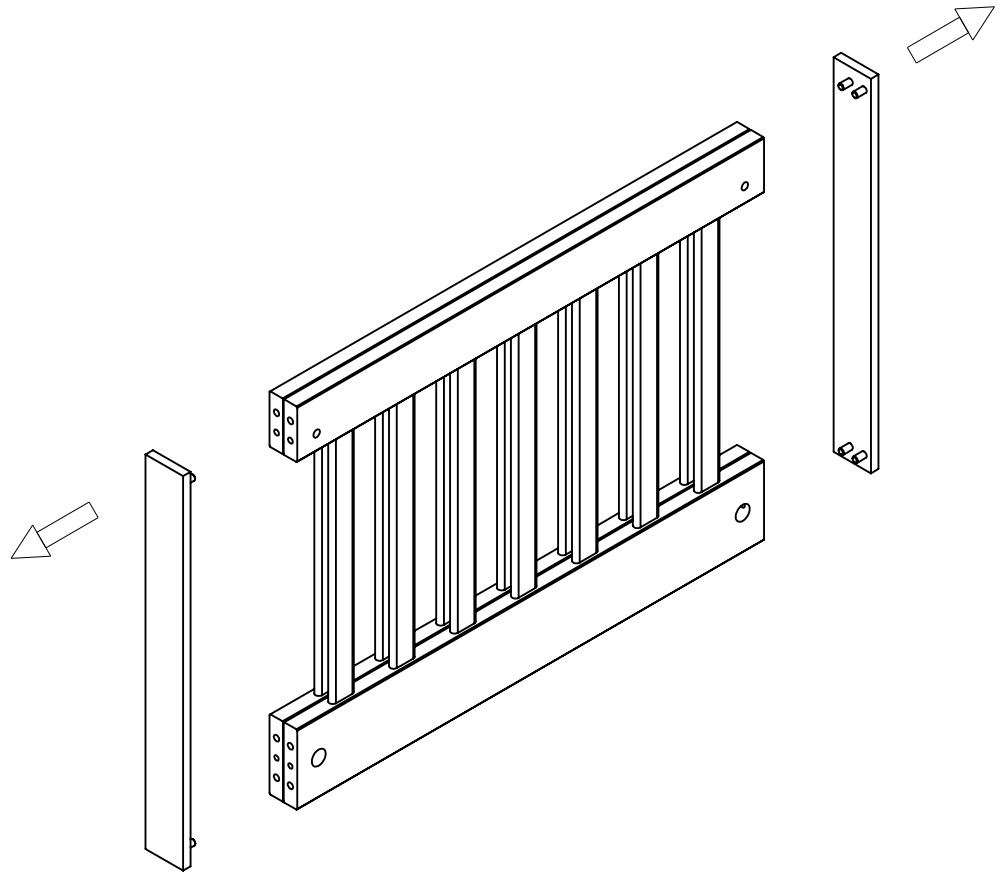

STEP 2

INSERT DOWEL (A) TO ALL COMPONENTS SHOWN BELOW

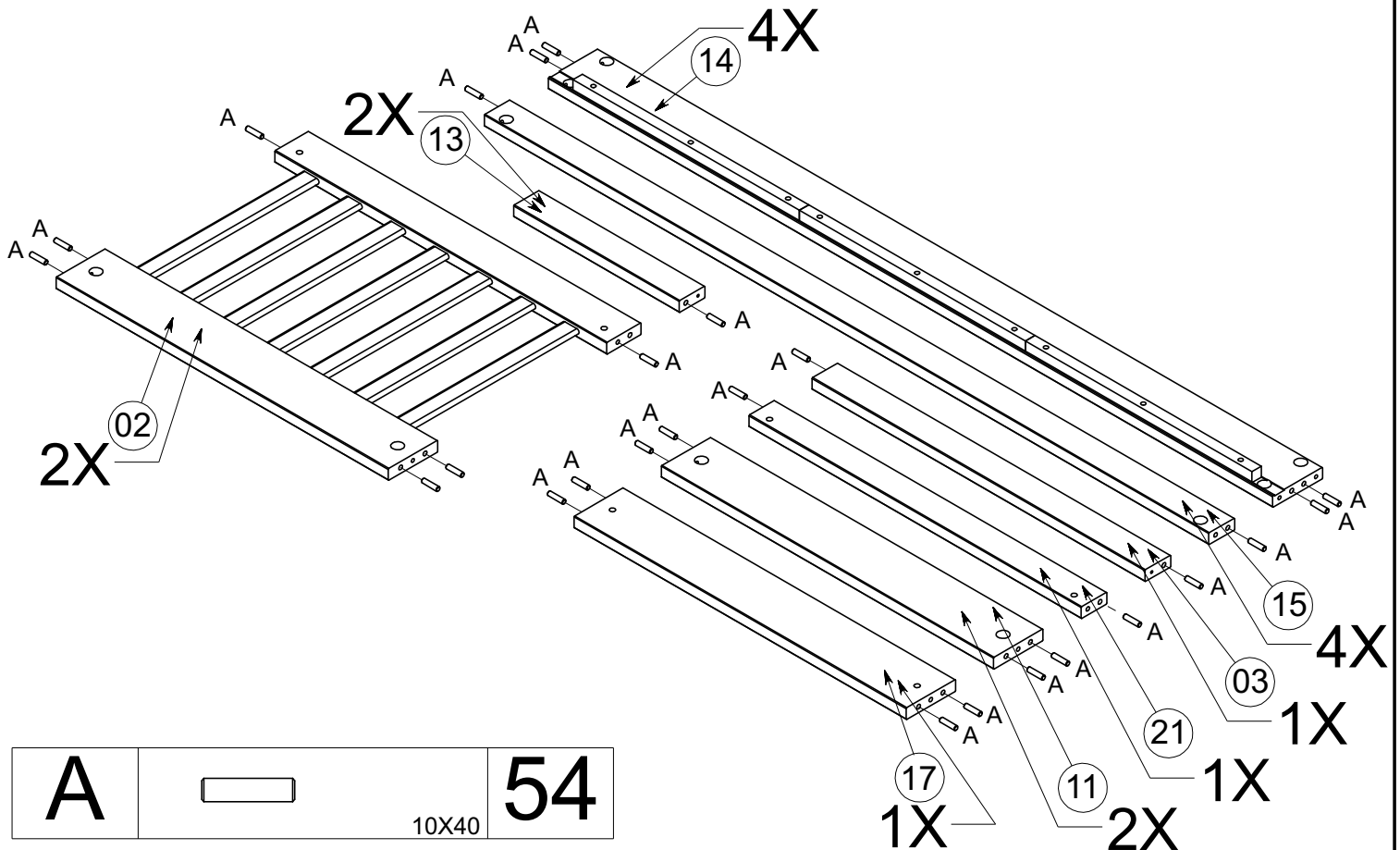

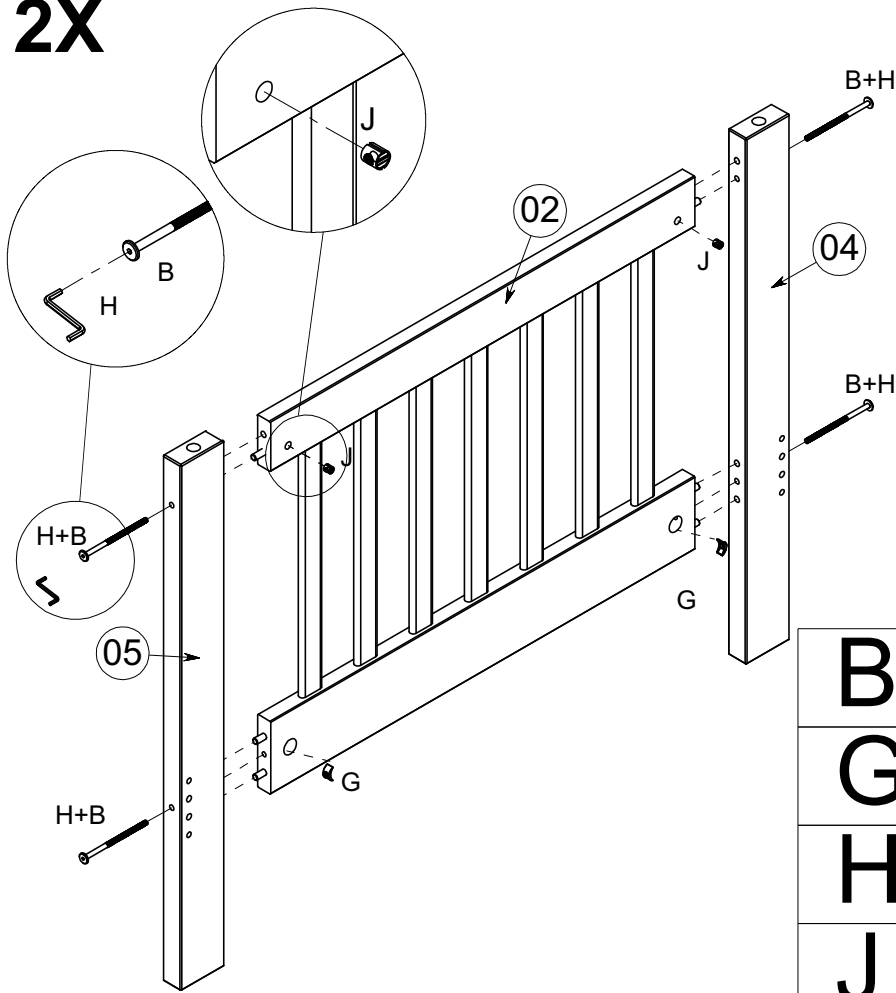

2X



STEP 3

Headboards x2

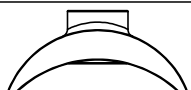
INSERT CROSS BOARDS
PANEL (02) TO POSTS (04, 05)
TIGHTEN BOTTOM CROSS BOARD
(02) USING BOLT (B) & NUT (G)
TIGHTEN TOP CROSS BOARD (02)
USING BOLT (B) & NUT (J)
REPEAT FOR SECOND
HEADBOARD

B	 (17) - 1/4X130	08
G		04
H		01
J	 19X11	04

STEP 4

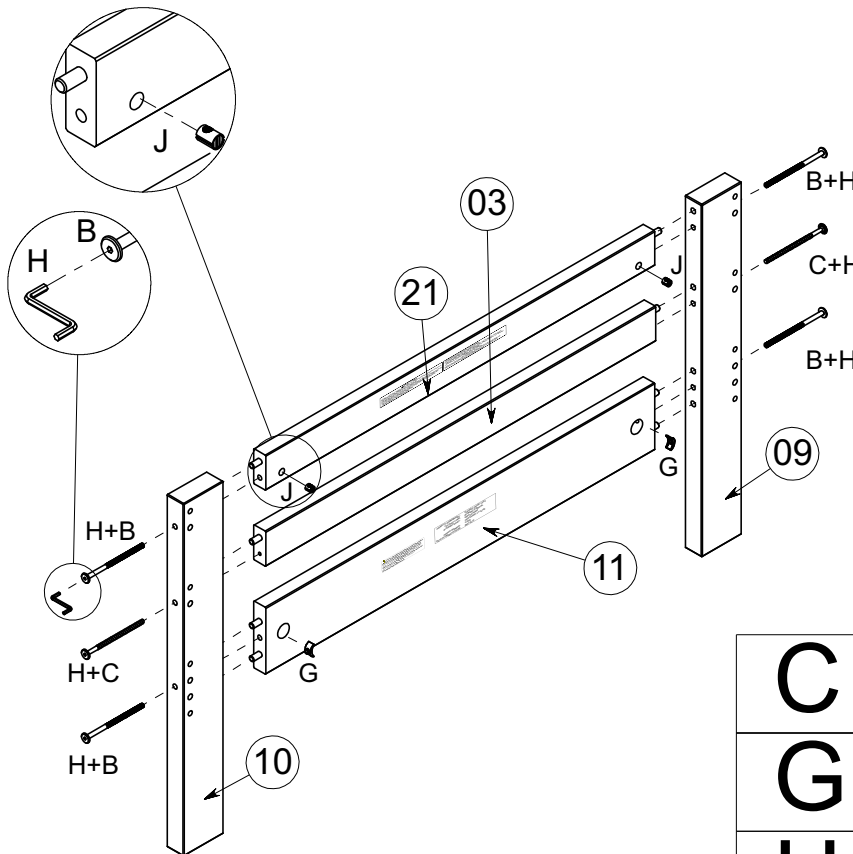



INSERT CROSS BOARDS (21, 03, 11)
TO POSTS (09, 10)

TIGHTEN CROSS BOARD (21) USING
BOLT (B) & NUT (J)

TIGHTEN CROSS BOARD (03)
USING LAG BOLT (C)

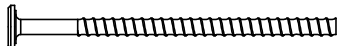
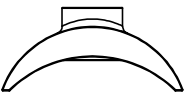
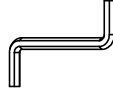
TIGHTEN CROSS BOARD (11)
USING BOLT (B) & NUT (G)

C	 (17) - 7X130	02
G		02
H		01
J	 19X11	02

B	 (17) - 1/4X130	04
----------	---	-----------

STEP 5

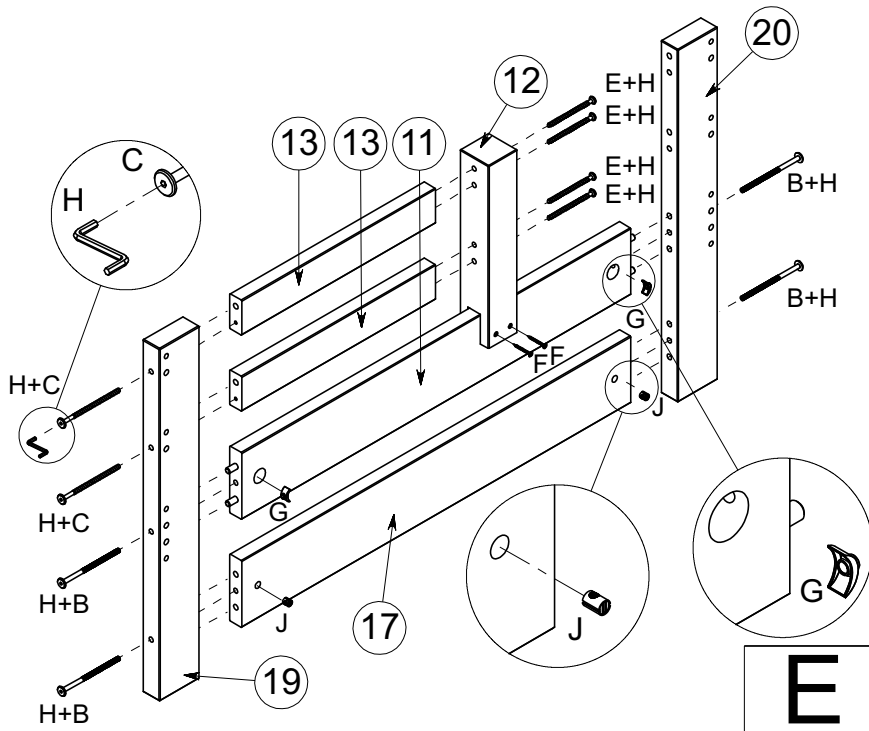





INSERT CROSS BOARDS (11, 17) TO POSTS (19, 20)

TIGHTEN CROSS BOARD (11) USING BOLTS (B) & NUTS (G)

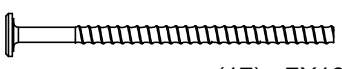
TIGHTEN CROSS BOARD (17) USING BOLTS (B) & NUTS (J)

ATTACH BOARDS (13X2) TO POST (12) USING LAG BOLTS (E) THEN ATTACH ASSEMBLED PIECES (13X2, 12) TO EITHER POST (19) OR POST (20) (DEPENDING ON THE SIDE YOU CHOOSE THE LADDER or STAIRCASE TO ATTACH) USE LAG BOLTS (C)

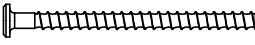
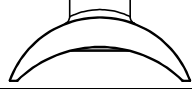
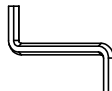
B	 (17) - 1/4X130	04
C	 (17) - 7X130	02
F	 CC 4X35	02

E	 (17) - 7X100	04
G		02
H		01
J	 11X11	02

STEP 6

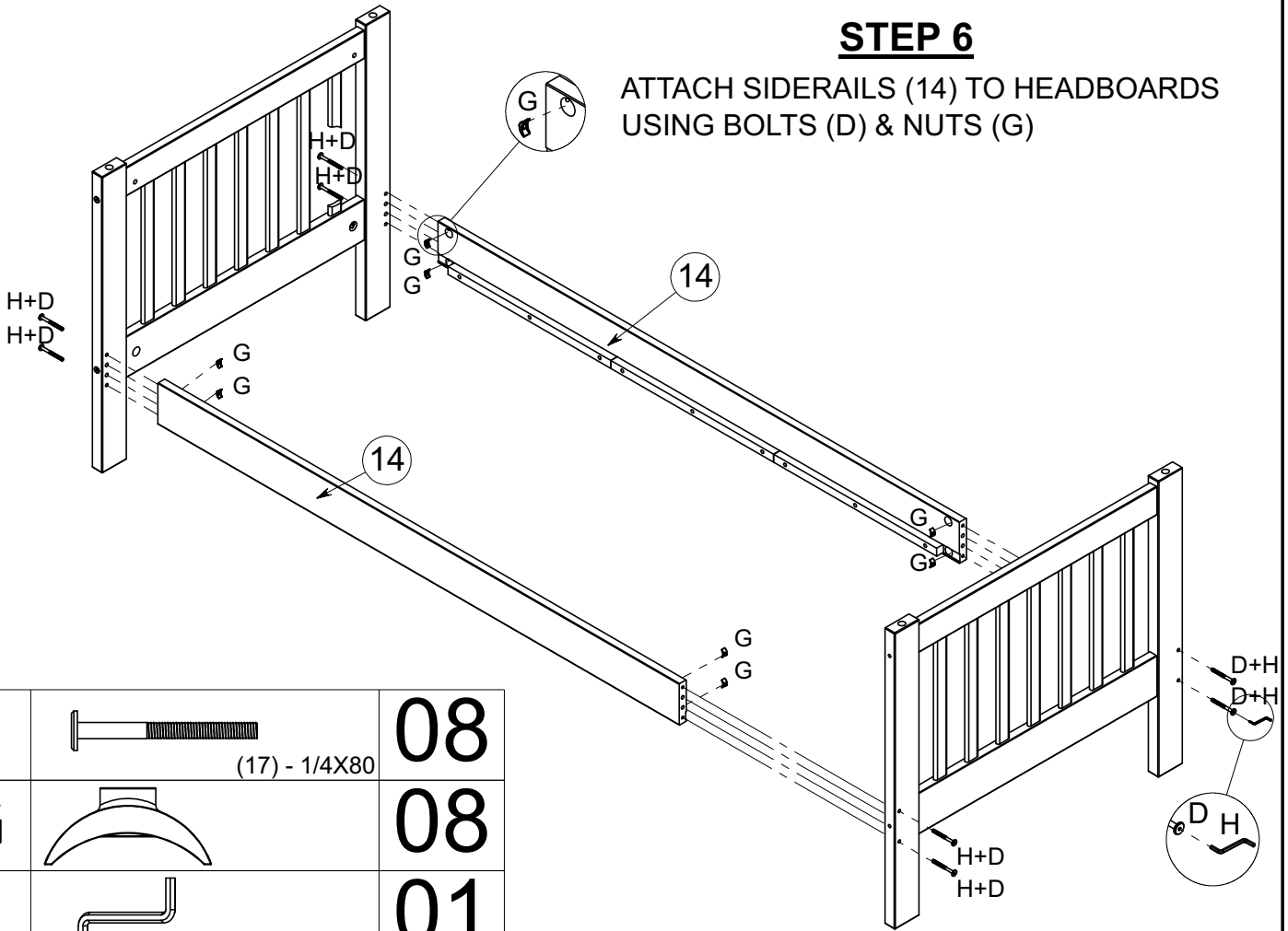

ATTACH SIDERAILS (14) TO HEADBOARDS USING BOLTS (D) & NUTS (G)

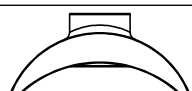
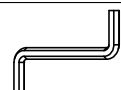
D	 (17) - 1/4X80	08
G		08
H		01

STEP 7

INSERT LARGE DOWELS (I) IN THE TOP OF HEAD BOARDS

LAY OUT SLAT KIT (16) ON THE CLEAT OF SIDERAILS (14).
 **BE SURE THE END SLAT ARE FLUSH WITH THE END OF THE CLEAT.

ATTACH BOTH END SLAT BOARDS & MIDDLE SLAT BOARD WITH SCREWS (F)

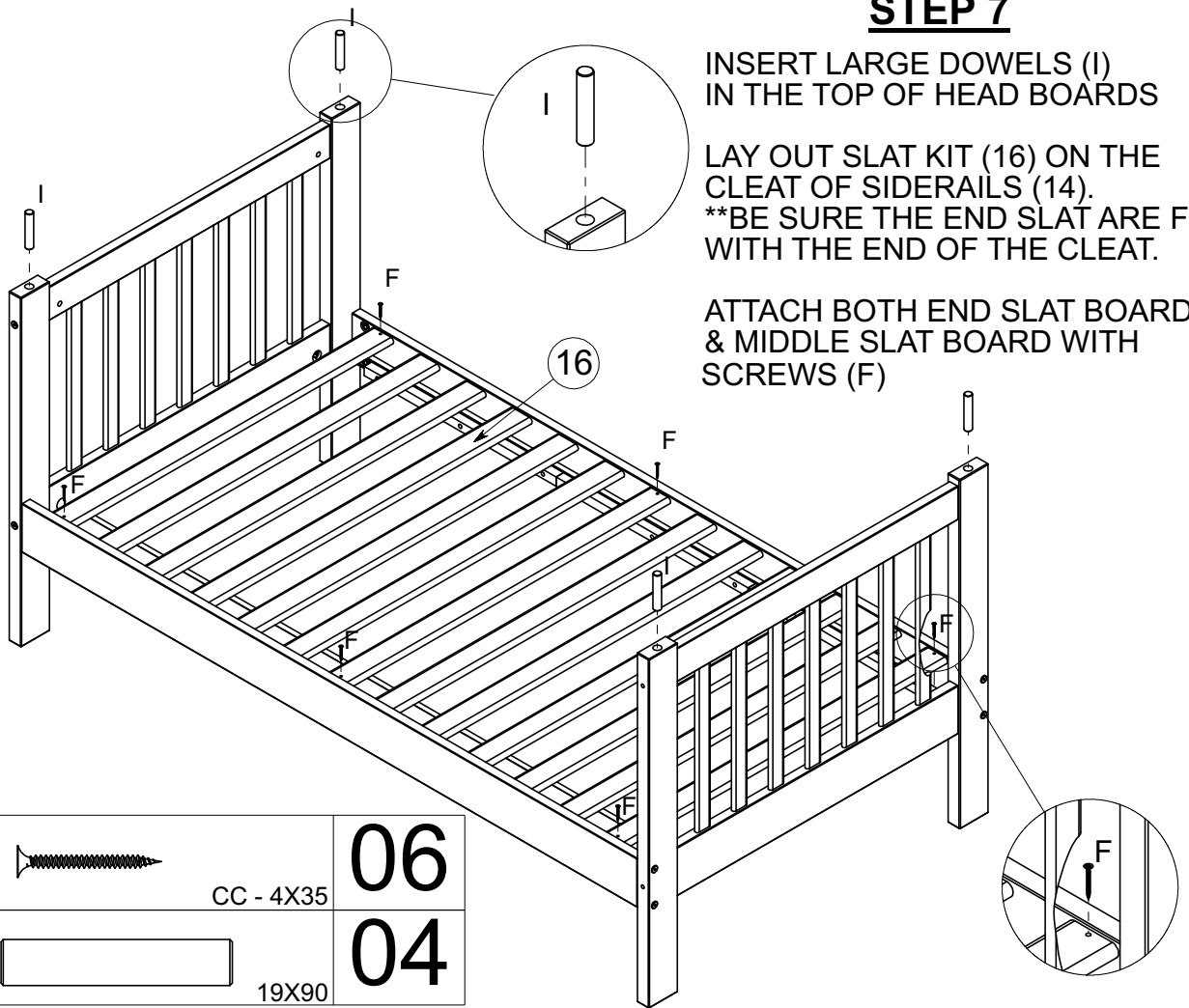

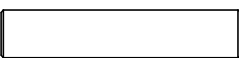
F	 CC - 4X35	06
I	 19X90	04

STEP 8

ATTACH SIDERAILS (14) & GUADRAILS (15) TO FOOTBOARDS USING BOLTS (D) & NUTS (G)

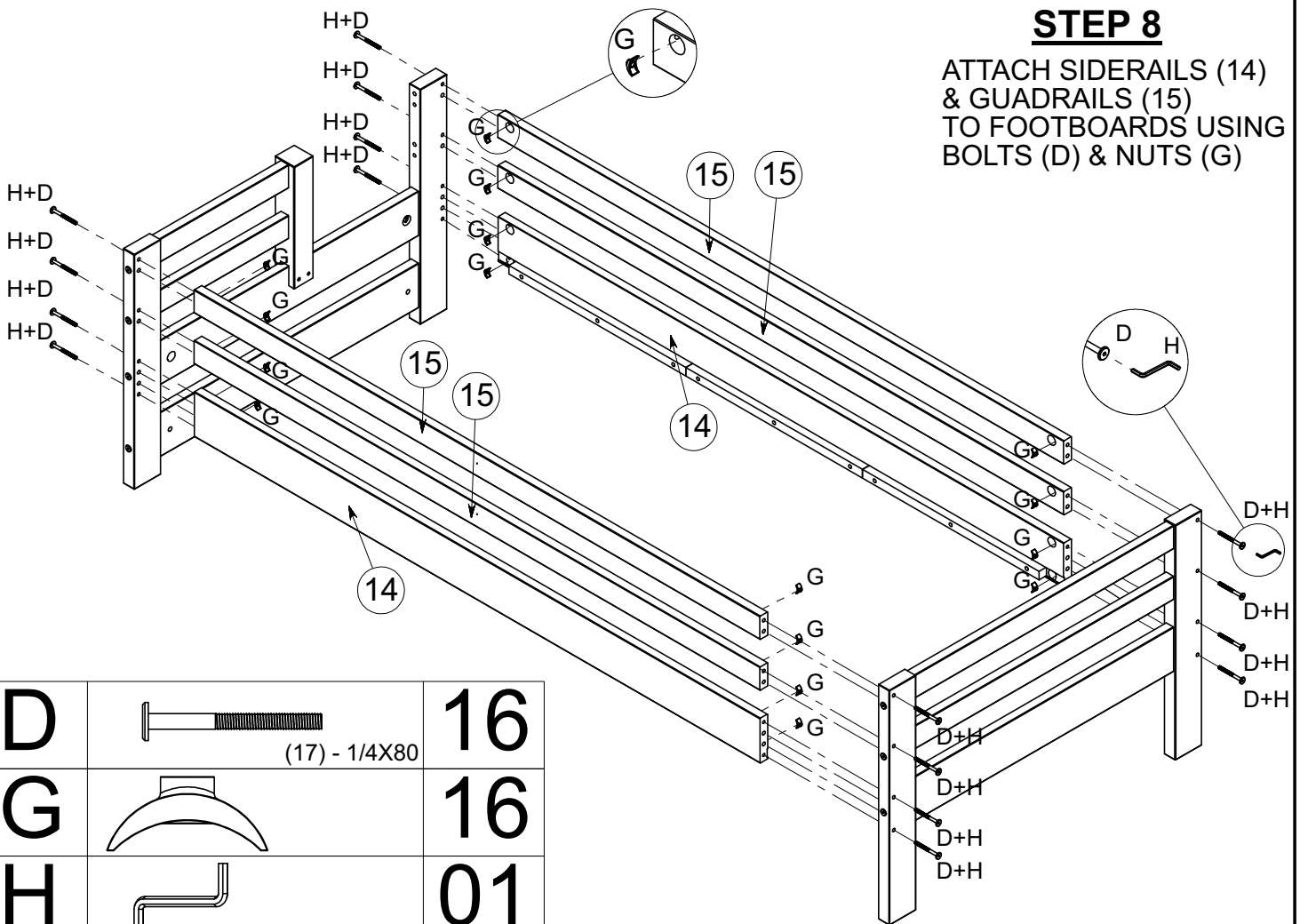

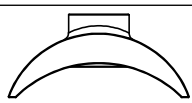
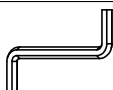
D	 (17) - 1/4X80	16
G		16
H		01

STEP 9

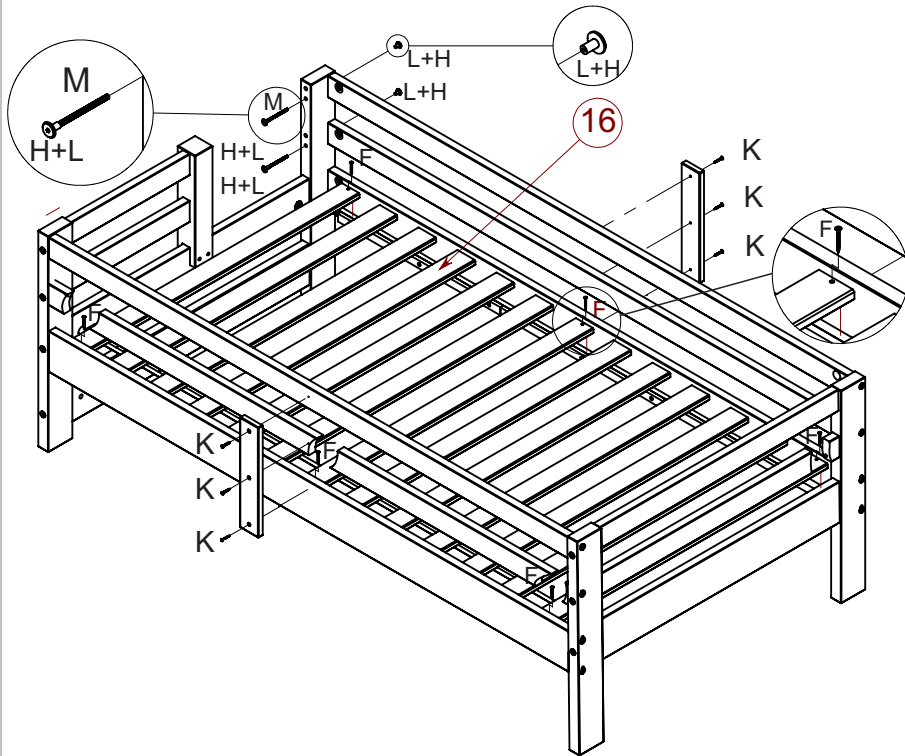



LAY OUT SLAT KIT (16) ON THE CLEAT OF SIDERAILS (14).
****BE SURE THE END SLAT ARE FLUSH WITH THE END OF THE CLEAT.**

ATTACH BOTH END SLAT BOARDS & MIDDLE SLAT BOARD WITH SCREWS (F)

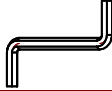
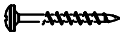
CENTER BOARDS (18) ON GUARDRAILS AND SIDERAILS. ATTACH USING SCREWS (K)

F		CC - 4X40	06
H			02
K			06

L		(17) 3/16X12	02
M		3/16X78	01

STEP 10

WITH TWO PEOPLE, LIFT THE TOP SECTION & PLACE ON THE HEADBOARDS, INSERTING LARGE DOWELS (I) INTO THE BOTTOM OF FOOTBOARDS.

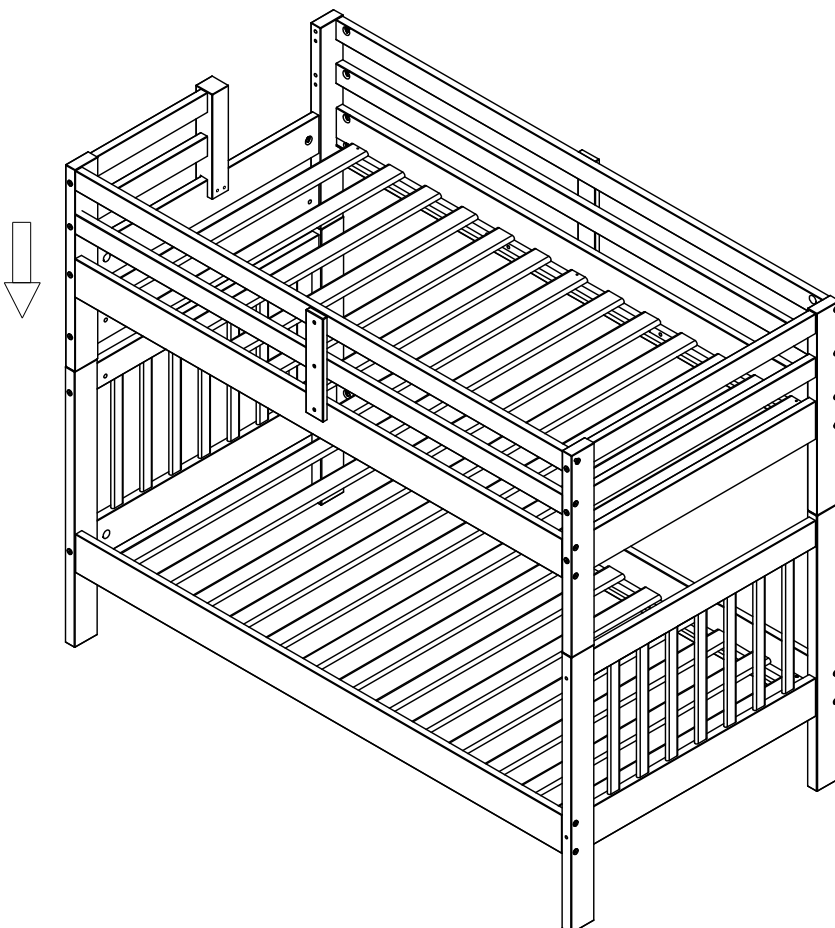

BUNK BED ASSEMBLY

SIZE OF MATTRESS

THIS BED IS DESIGNATED TO USE A MATTRESS (74" TO 75") LONG, AND (37-1/2" TO 38-1/2") IN WIDTH AND THE ENCLOSED SLAT KIT SYSTEM. THE TOTAL THICKNESS OF MATTRESS AND FOUNDATION MUST NOT EXCEED 9 1/4". NOTE: THERE MUST BE AT LEAST 5" FROM MATTRESS SLEEPING SURFACE TO TOP EDGE OF GUARDRAIL.

SAFETY WARNINGS

1. FOLLOW THE INFORMATION ON THE WARNINGS APPEARING ON THE UPPER BUNK END STRUCTURE AND ON THE CARTON. DO NOT REMOVE WARNING LABEL FROM BED.
2. ALWAYS USE THE RECOMMENDED SIZE MATTRESS OR MATTRESS SUPPORT, OR BOTH, TO HELP PREVENT THE LIKELIHOOD OF ENTRAPMENT OR FALLS.
3. SURFACE OF MATTRESS MUST BE AT LEAST 5 INCHES BELOW THE UPPER EDGE OF GUARDRAILS.
4. DO NOT ALLOW CHILDREN UNDER 6 YEARS OF AGE TO USE THE UPPER BUNK.
5. PERIODICALLY CHECK AND ENSURE THAT THE GUARD RAIL, LADDER, AND OTHER COMPONENTS ARE IN THEIR PROPER POSITION, FREE FROM DAMAGE, AND THAT ALL CONNECTORS ARE TIGHT.
6. DO NOT ALLOW HORSEPLAY ON OR UNDER THE BED AND PROHIBIT JUMP ON THE BED.
7. ALWAYS USE THE LADDER FOR ENTERING OR LEAVING THE UPPER BUNK.
8. DO NOT USE SUBSTITUTE PARTS. CONTACT MANUFACTURER OR DEALER FOR REPLACEMENT PARTS.
9. USE OF A NIGHT LIGHT MAY PROVIDE ADDED SAFETY PRECAUTION FOR A CHILD USING THE UPPER BUNK.
10. ALWAYS USE GUARD RAILS ON BOTH LONG SIDES OF THE UPPER BUNK.
11. IF THE BUNK BED WILL BE PLACED NEXT TO A WALL, THE GUARD RAIL THAT RUNS THE FULL LENGTH OF THE BED SHOULD BE PLACED AGAINST THE WALL TO PREVENT ENTRAPMENT BETWEEN THE BED AND THE WALL.
12. PROHIBIT MORE THAN ONE PERSON ON THE UPPER BUNK.
13. THE USE OF WATER OR SLEEP FLOTATION MATTRESSES IS PROHIBITED.
14. KEEP THESE INSTRUCTIONS FOR FURNITURE REFERENCE.

STRANGULATION HAZARD – NEVER ATTACH OR HANG ITEMS TO ANY PART OF THE BUNK BED THAT ARE NOT DESIGNATED FOR USE WITH THE BED: FOR EXAMPLE, BUT NOT LIMITED TO HOOKS, BELTS, AND JUMP ROPES.