

ASSEMBLY INSTRUCTIONS

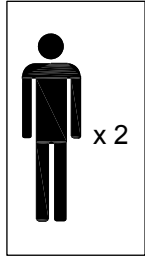
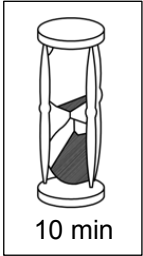

USEFUL HINTS BEFORE YOU START:

1. Read each step carefully before starting.
2. It is important that each step is performed in correct order to avoid difficulties.
3. Identify, sort and count the parts before assembly.
4. Assemble the product on packaging cardboard to prevent scratch or damage.
5. Using incompatible hardware might cause damage to the product.

IMPORTANT NOTES:

1. DO NOT FULLY-TIGHTEN the nut until all nuts are ready assembled.
2. DO NOT OVER-TIGHTEN the nut to avoid causing damages to the thread.
3. Keep all hardware parts out of reach of children.



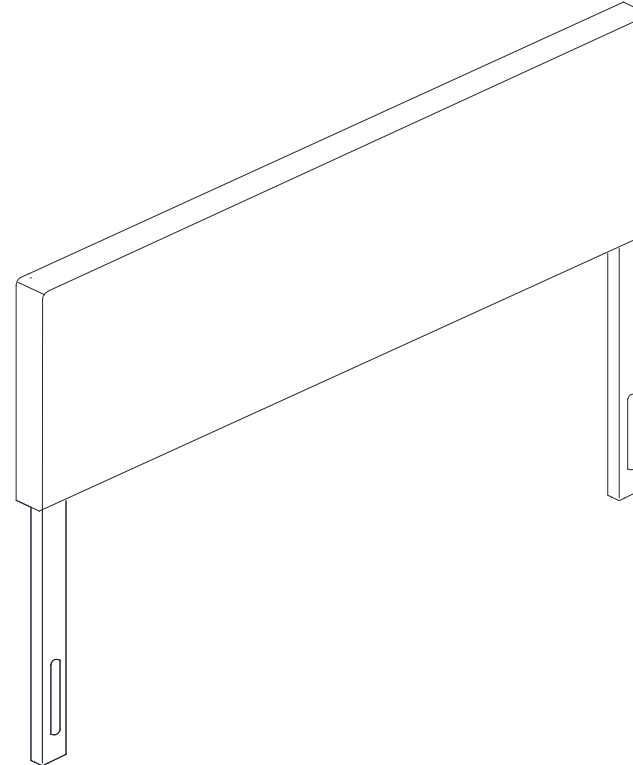



NEED HELP? For replacement requests or product inquiries, please contact our Customer Service Team by emailing us. Thank you for selecting!



PLAIN HEADBOARD

ASSEMBLY INSTRUCTION

STEP 1

NO	PART LIST	QTY
1	 HEADBOARD CUSHION 1PC	1PC
2	 HEADBOARD LEG 2PCS	2PCS
NO	HARDWARE LIST	QTY
A	 JCBC SCREW M8 X 50 4 PCS	4 PCS
B	 SPRING WASHER 4PCS	4PCS
C	 FLAT WASHER SMALLER 4PCS	4PCS
D	 L - KEY M5 X 65mm 1PC	1PC

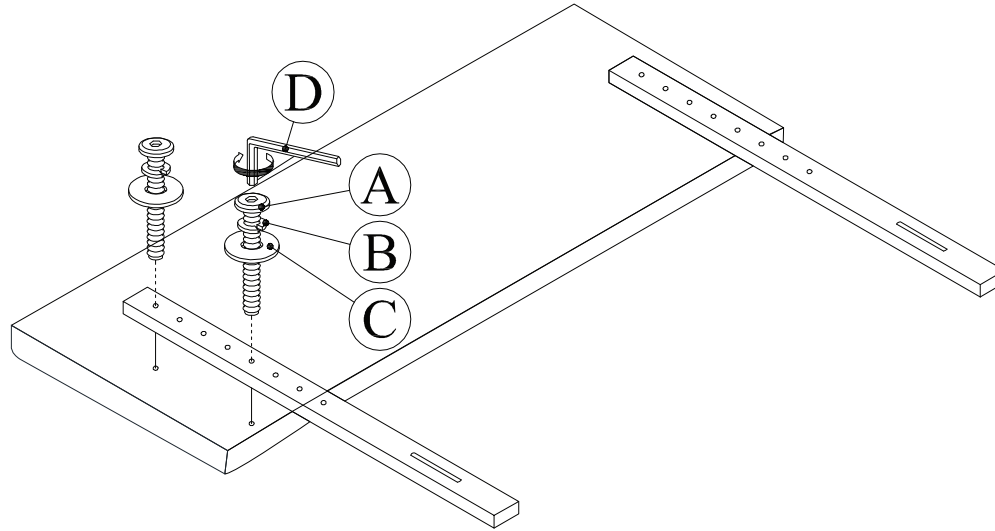

STEP 2

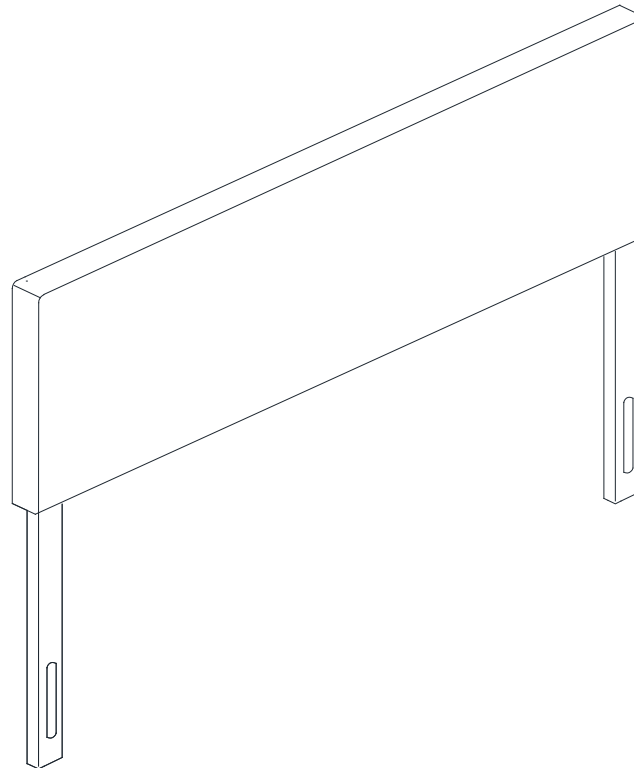

ASSEMBLY
COMPLETED