

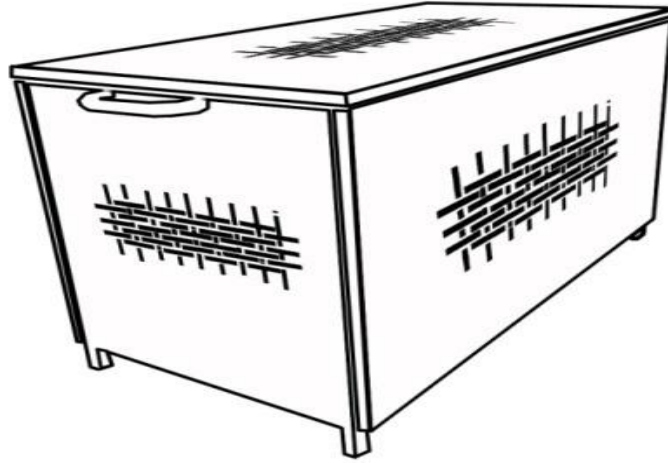



Assembly Instructions

Caution : You must read this before you proceed



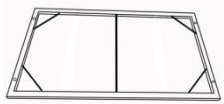
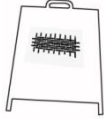

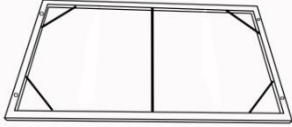
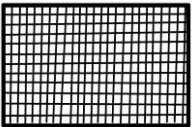

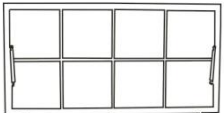

User Reminder : DO NOT PLACE heavy loads on the LID Cover. DO NOT SIT on this Trunk Storage.

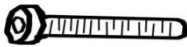

Parts List

Label	Picture	Description	QTY
A		SIDE PANEL with Hinge Joints TO CONNECT THE TOP LID	1
B		PANEL	1
C		PANEL WITH WHEELS	1
D		SIDE PANEL	1
E		BASE PANEL	1
F		TRUNK - INNER LINING	1
G		LID - TOP PANEL with pressure hinge	1

Hardware

Label	Picture	Description	QTY
1		M8*40 SCREW	10
2		M6*25 SCREW	8
3		M6*50 SCREW	4
4		M8 Washer Ring	14
5		M6 Washer Ring (PVC gasket)	6
6		M6 Washer Nut	3
8		Wrench	1
9		M4 Allen key	1
10		M5 Allen key	1

Assembly Preparation

Before Beginning Assembly:

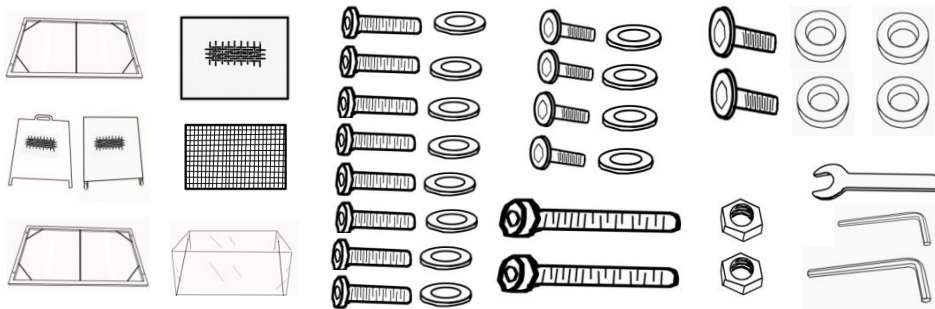

- Read instructions, cover to cover-



- Have 2 adults on hand for assembly-



- Do not assemble on flooring or carpet-



- Assemble on a clean non-marring surface (packing foam)-



- Save all packaging until finished-

Assembly Steps

Step 1

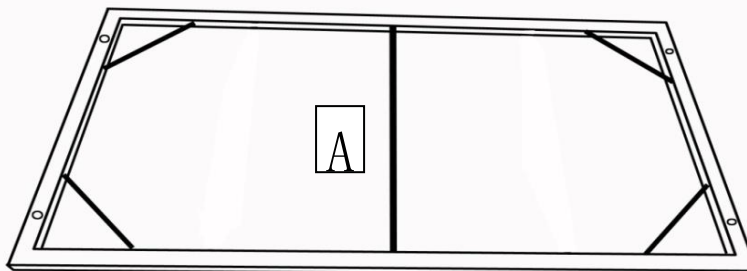

Open the carton and place SIDE PANEL A onto a clean and soft surface.

Step 2

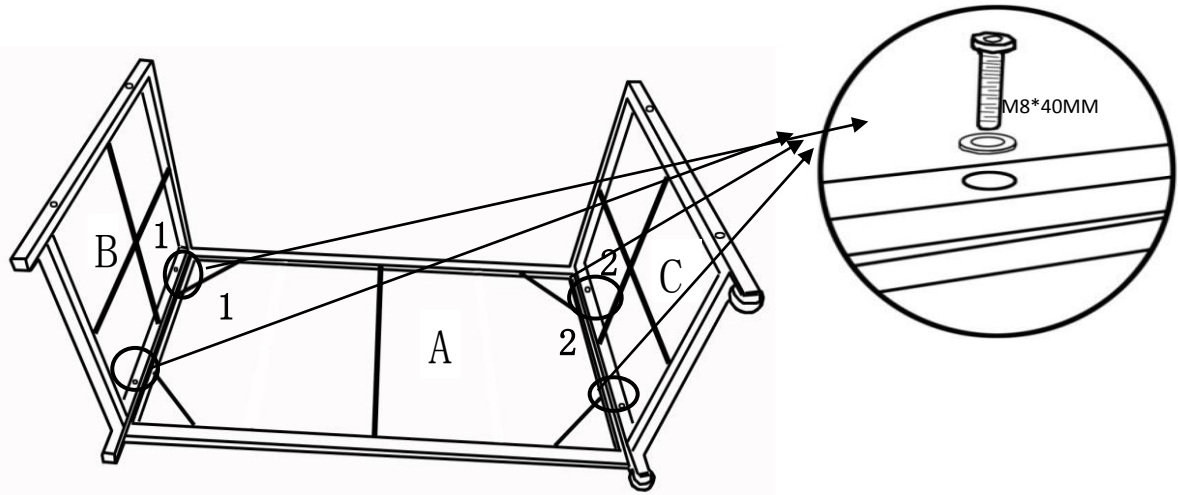

Affix the mounting points #1 in Panel(A) and Panel B.
Then, repeat the same process with mounting points #2, as depicted in picture Step 2, above.
As indicated above, use 4 Bolts (M8*40MM) to attach these mounting points.
DO NOT OVERTIGHTEN any of these 4 Bolts.

Step 3

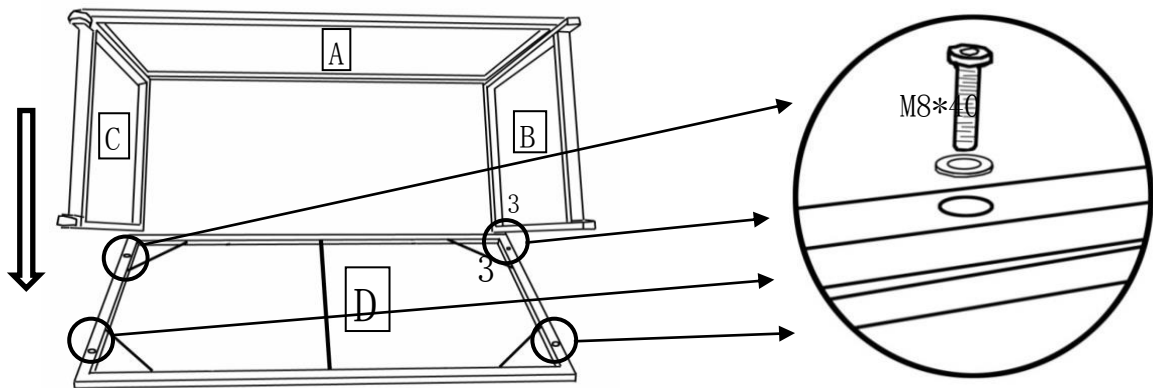

At this stage, turn over the above preattached ABC panels.
Assemble Panel D to the preattached Panels B & C.
Ensure the mounting points of site #3 on the Panel B matches to the mounting points on Panel D;
As indicated in the above, use 4 Bolts (M8*40MM) to attach these mounting points .
DO NOT OVERTIGHTEN any of these 4 Bolts.

Step 4

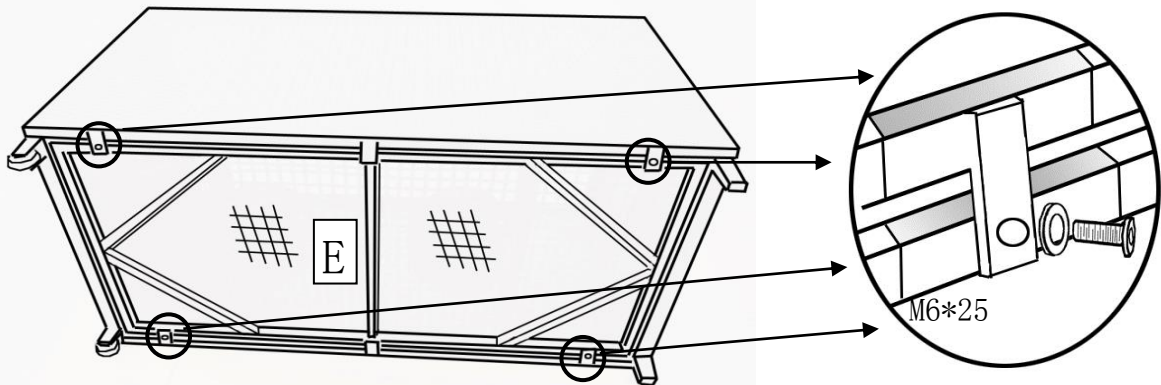

As the above picture shows in Step 4, place Base Panel (E) to the bottom of the Storage Trunk.
Use 4 x(M6*25MM bolts into the mounting points.
Now proceed to secure and tighten these 4 bolts.

Step 5

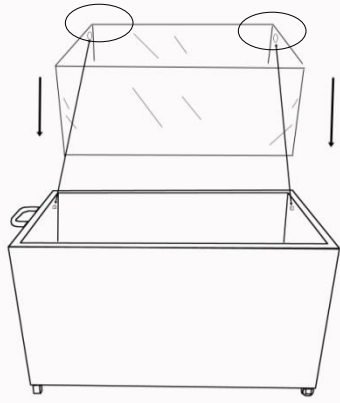

Spread out the Trunk Inner Lining (F).

Set as shown into the box.

Then smooth out the corresponding Velcro tapes till all tapes meets and seals tightly.

There are 02 holes in the Lining that shall be aligned into the pressure hinge mounting point.

Step 6

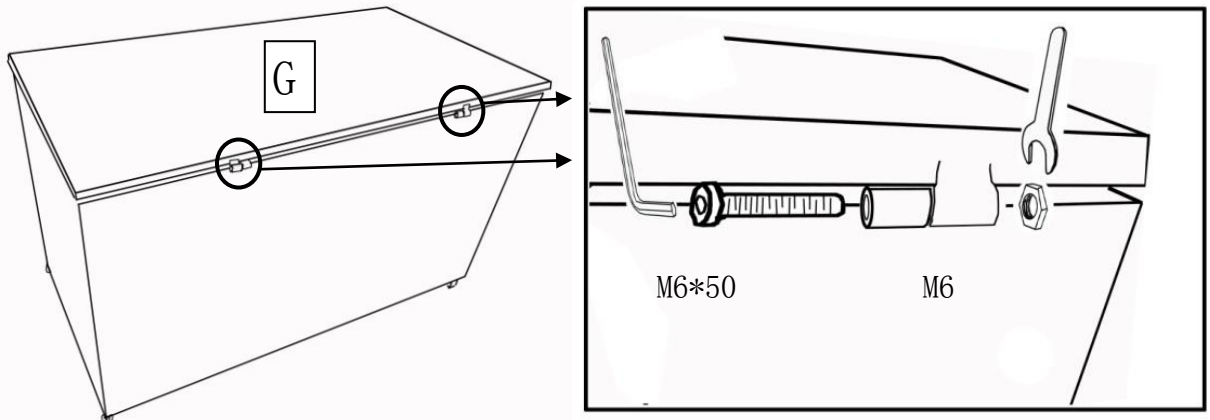

Put the LID TOP PANEL (G) as shown above.

Match the two hinge points.

Once the hinge points matches, place Screw M6*50 through.

Secure and lock in place with M6 washer-nut.

DO NOT OVERTIGHTEN these washer-nuts.

Step 7

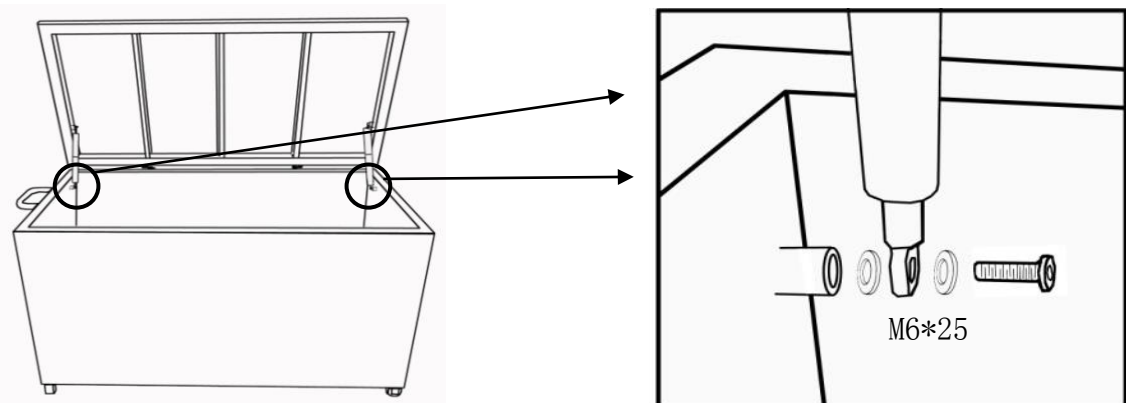

Turn in and lock the screw as shown in picture.

Both sides of the pressure hinge arm, would require 02 PVC Gasket (5).

Upon completion of tightening in the screw, close the lid.

Step 8

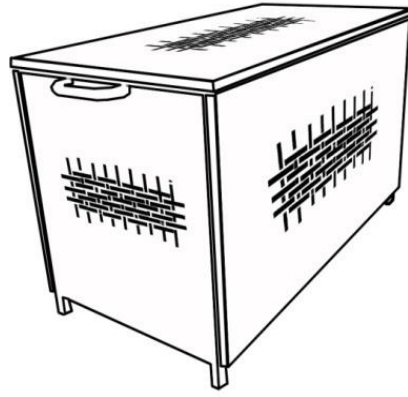

Now go back to all the Nuts and Bolts and Screws that are previously attached.
Once all Screws and Bolts are fully tighten in.

In a sequential manner, fully secure and tighten up all nuts and bolts and screws.

Place the Trunk Lining into the storage.

Spread out the Trunk Inner Lining (F).

Smooth out the corresponding Velcro tapes till all tapes meets and seals tightly.

The Trunk Storage is ready for use.

Care & Maintenance



● Do not put **HOT** items directly on furniture surface.

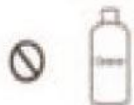

● Do not clean furniture with **HARSH** cleansers or polish.



● To prolong product lifetime, **AVOID** placing furniture under direct sunlight.



● Do not place furniture near **heating or cooling** vents.



● Do not write on furniture without a padded barrier to protect the surface.



● To prolong the product lifetime, avoid extended and lengthy exposure to rain and sunshine. Where possible, place under covers and or patio and or awnings.



● For residential use only. Not for commercial use.



● Stains may be removed with mild soap solution and damp cloth.



● Dust and pick-up spills using a clean, non-colored, lint-free cloth.