

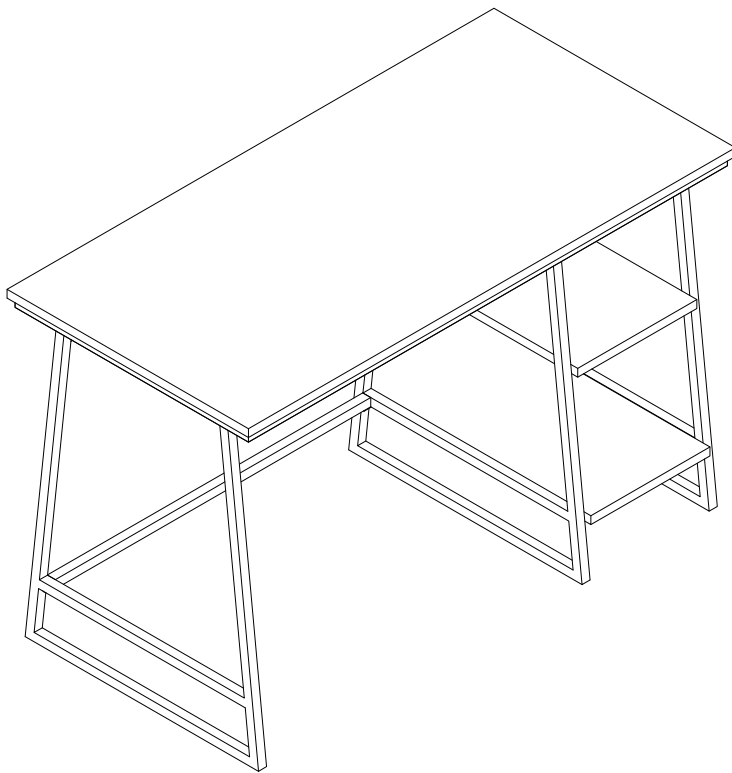

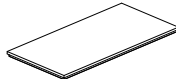

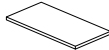

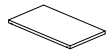
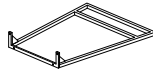
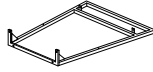

Note:

A packet with complete set of hardware can be found by pulling the red ribbon that's easily visible upon opening the box.

Assembly Instructions, REVERSIBLE TIER SHELF DESK



A	Top Panel		1
B	Bottom Shelf		1
C	Middle Shelf		1
D	Left Side Frame		1
E	Right Side Frames		2
F	Metal Rail		1
G	Long Bolts		12
H	Short Bolts		2
I	Lock Washers		14
J	Flat Washers		14
K	Allen Wrench		1
L	Shelf Supports		4
M	Screws		4

Step 1

1.1 Put the top panel (A) upside down on a soft surface, place two right side frames (E) with L-brackets and tabs facing each other. Fasten with 8 long bolts (H), lock washers and flat washers. Do not tighten.

1.2 Place the left side frame (D) with L-brackets facing inward, fasten with 4 long bolts (H) & lock washers and flat washers. Do not tighten.

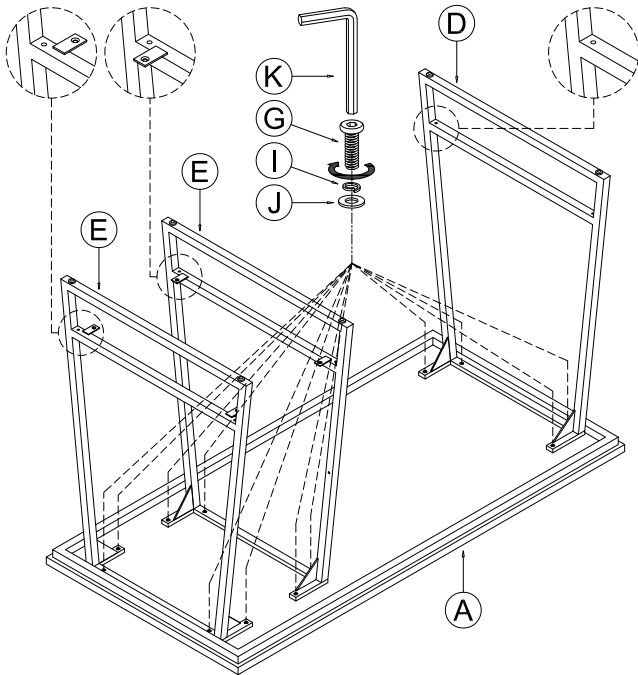

Step 2

2.1 Fasten the metal rail (F) onto left side frame and right side frame with 2 short bolts & lock washers and flat washers. Push frames onto metal rail without gap to tighten two bolts. The metal rail can be either fasten on the front or back.

2.2 Slide bottom shelf (B) into metal frames, hold the panel to screw four screws through metal frames' tabs into the plastic inserts. Tighten all four screws for pushing metal frames to bottom panel without gap.

2.3 Tighten all bolts on step 1.1 and 1.2.

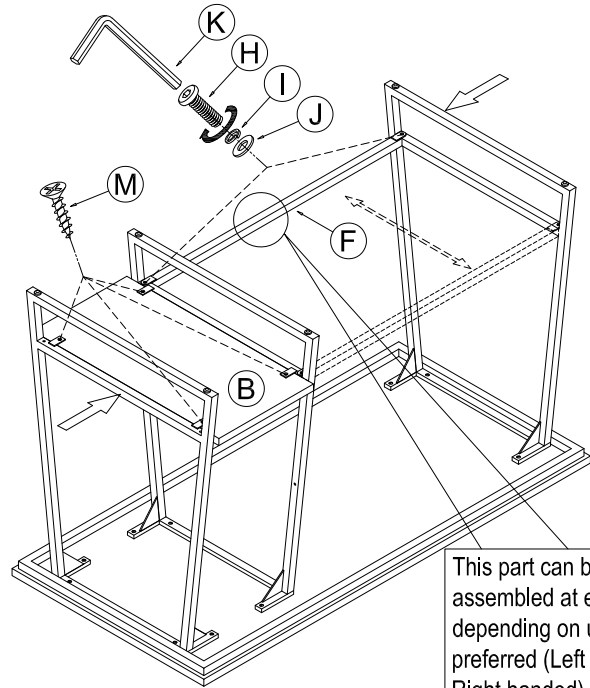

This part can be assembled at either side depending on user's preferred (Left handed or Right handed) desk orientation.

Step 3

3.1 Place the writing desk upright. Screw-in shelf supports on side frames and place the middle shelf (C) on.

3.2 Adjust the levelers on the bottom of side frames if needed.

3.3 If you prefer the shelf tier on the left side, you only need to switch and fasten the metal rail on the front, then rotate the desk into 180 degrees before step 3.

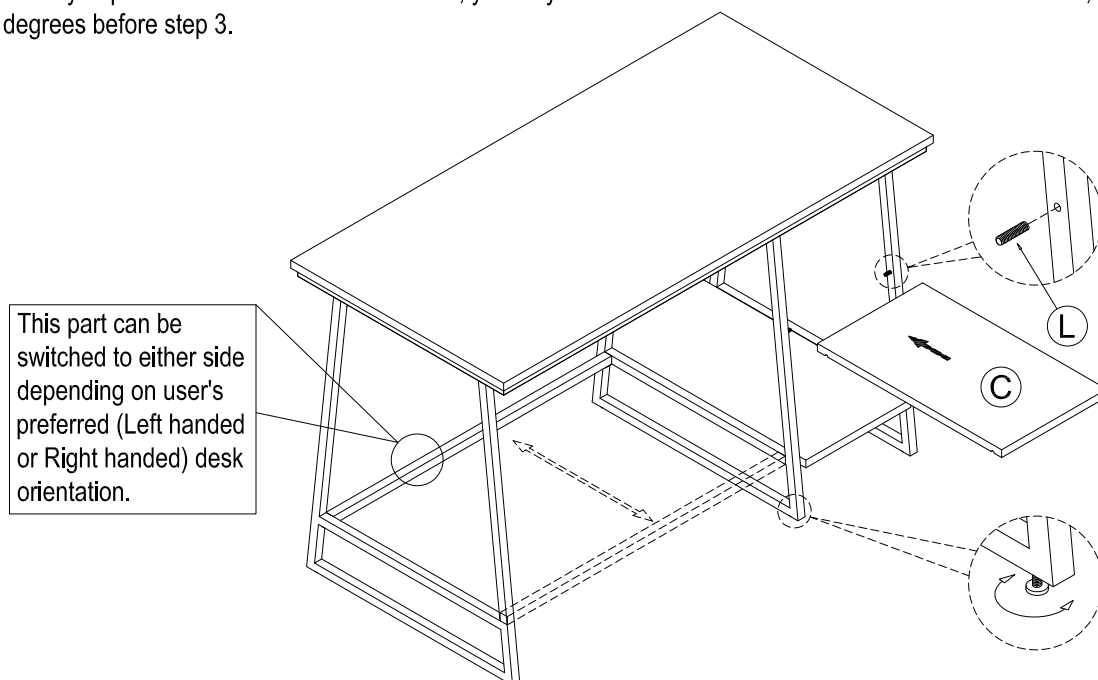

This part can be switched to either side depending on user's preferred (Left handed or Right handed) desk orientation.