

INSTRUCTIONS
 INSTRUCTION
 ANWEISUNG
 사용설명서
 取扱説明書
 ISTRUZIONI PER L'INSTALLAZIONE
 LIBRO DE INSTRUCCIONES



Product Name: Dog cage

A*2

HINTERTÜR
 背板
 PORTE ARRIÈRE
 BACK STEEL PANEL
 후문
 Pannello posteriore
 Panel trasero

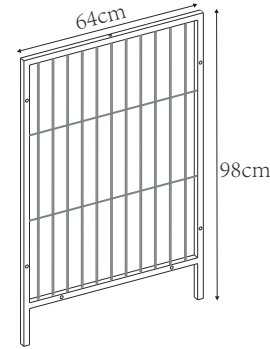

B*4

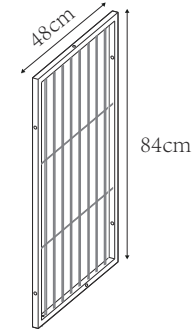

C*2

UNTERE TÜR
 底板
 PORTE DU BAS
 BOTTOM PANEL
 밑판
 Pannello inferiore
 Panel inferior

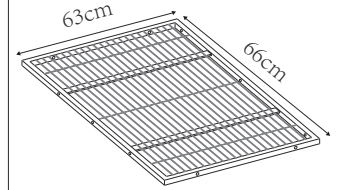

D*1

HAUSTÜR 1
 ドア 1
 PORTE D'ENTRÉE 1
 FRONT DOOR 1
 정문 1
 Porta anteriore 1
 Puerta frontal 1



E*1

HAUSTÜR 2
 ドア 2
 PORTE D'ENTRÉE 2
 FRONT DOOR 2
 정문 2
 Porta anteriore 2
 Puerta frontal 2

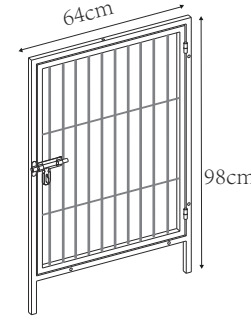

F*2

OBERE TÜR
 天板
 PORTE DU HAUT
 TOP PANEL
 정수리
 Pannello superiore
 Panel superior

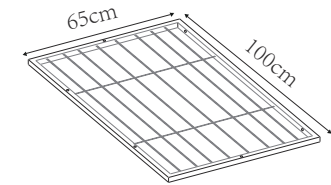

G*2

TRENNTÜR
 仕切り
 SÉPARATEUR
 DIVIDER
 격자문
 Pannello divisorio
 Panel divisorio

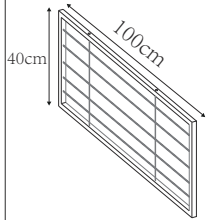

H*2

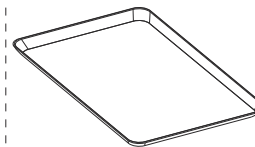

I*2



J*2

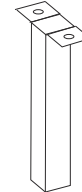

K*48

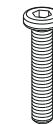

M6 *30mm

L*40



M6 *18mm

M*8



M6

N*1

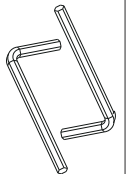

O*1



1

1. 金網が外に向けてください、底板の金網が上に向けてください

1. 철망이 밖으로 향하십시오, 바닥판의 철망이 위로 향하세요

1. Bitte Installieren Sie das Drahtgeflecht nach au B en
Bitte Installieren Sie das Drahtgeflecht der Bodenplatte nach oben

1. Install the metal wire mesh to the outward
Install the bottom plate wire mesh upwards

1. Installez la grille métallique vers l'extérieur
Installez la grille métallique de la plaque inférieure vers le haut

1. La rete metallica rivolta verso l'esterno, la rete metallica sul pavimento rivolta verso l'alto

1. La malla de alambre hacia afuera, la malla de alambre en el piso hacia arriba

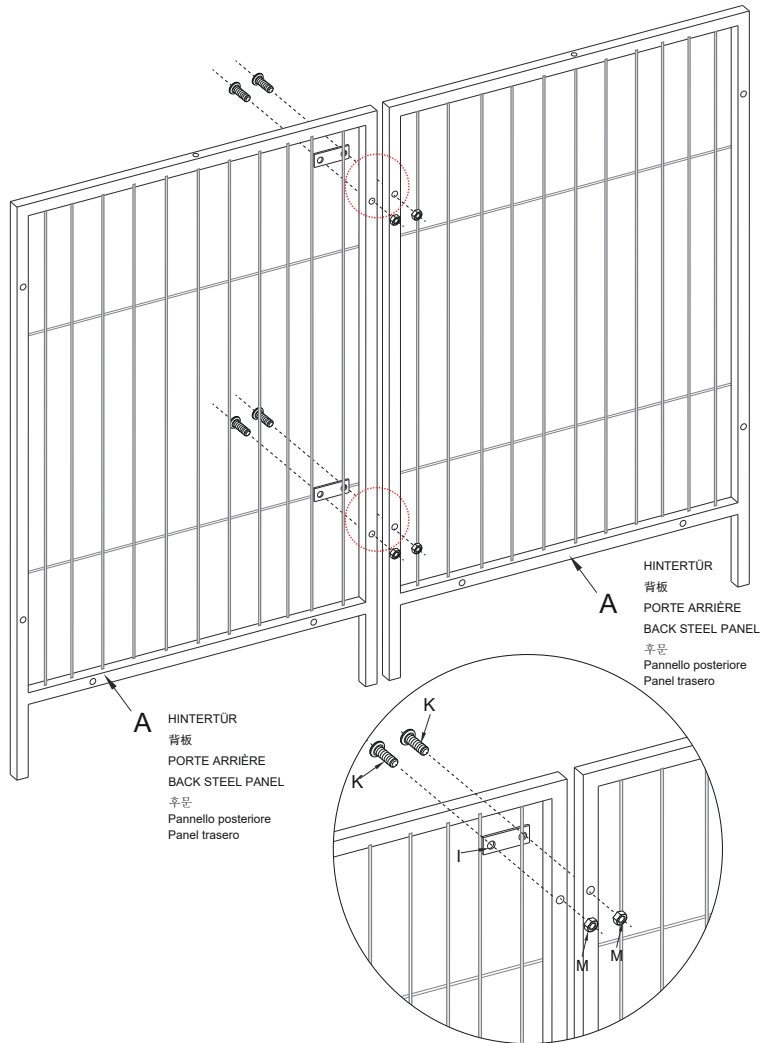
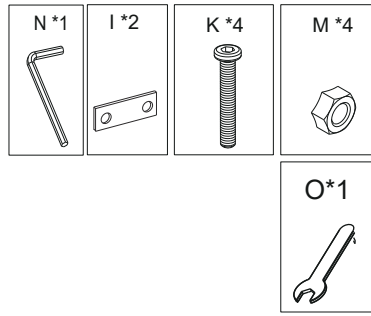

2

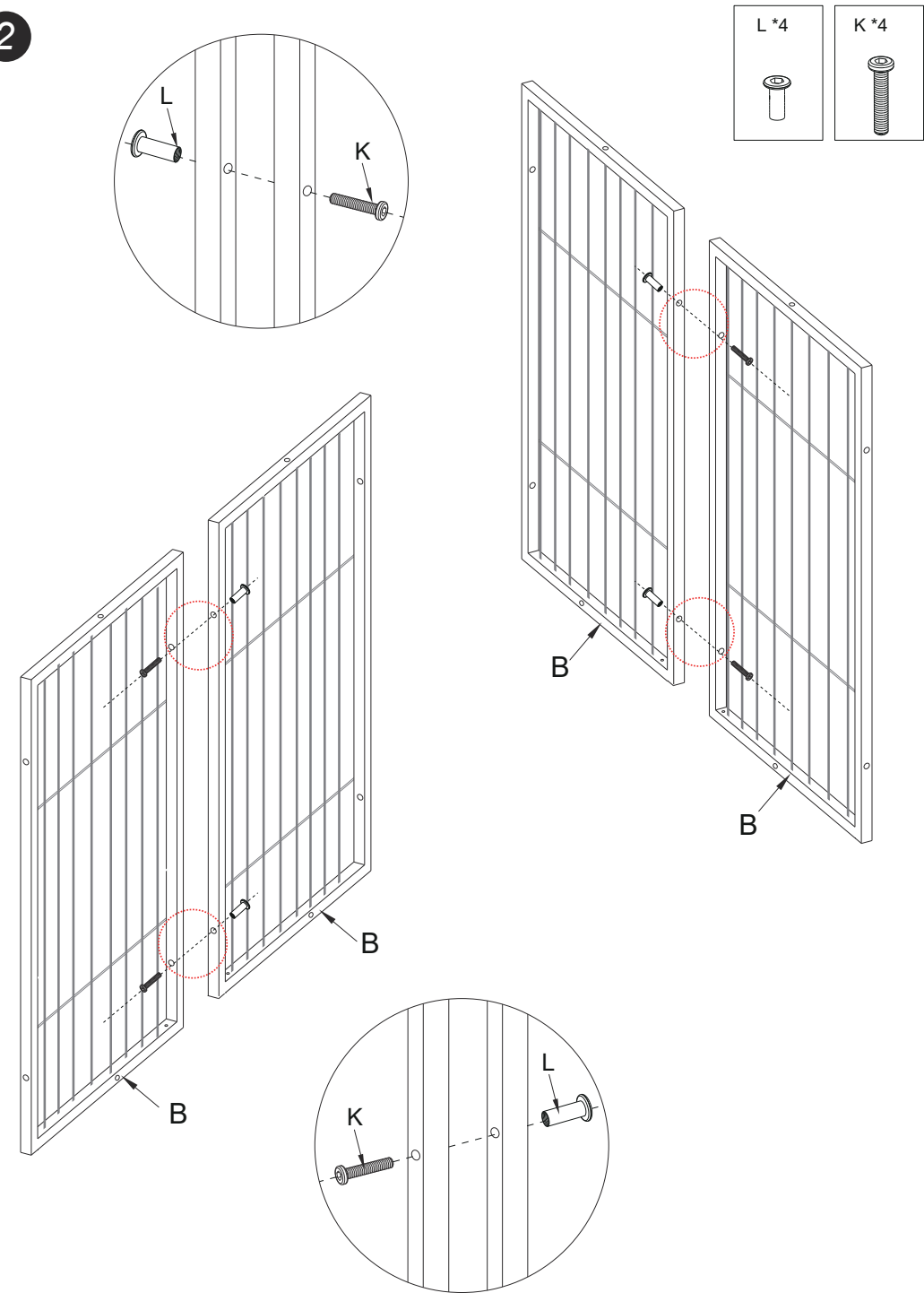

3

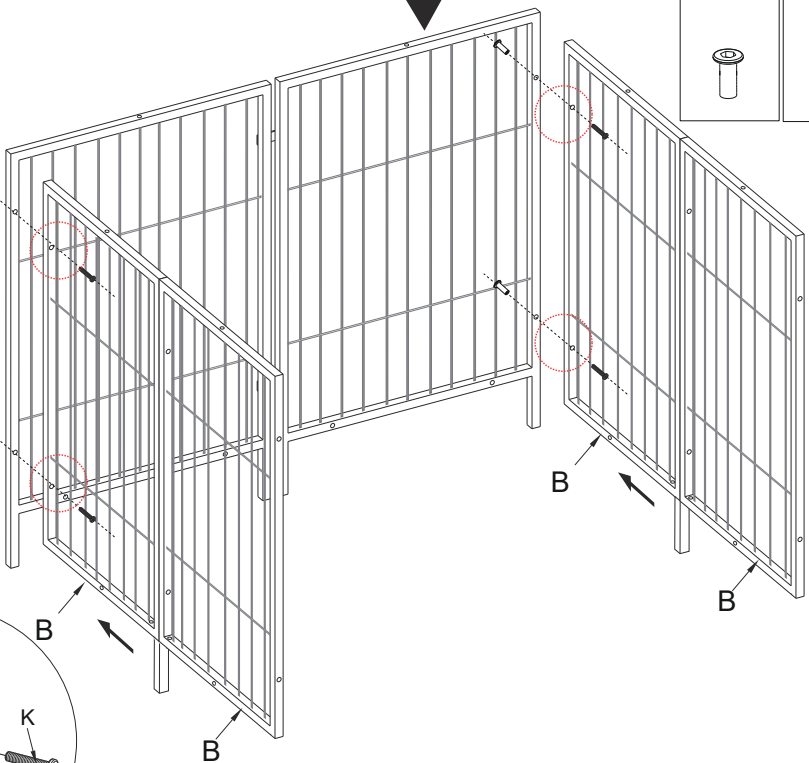
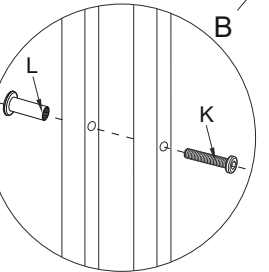
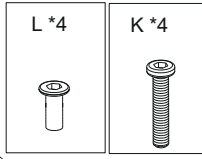
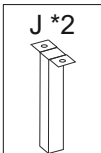
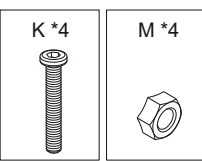
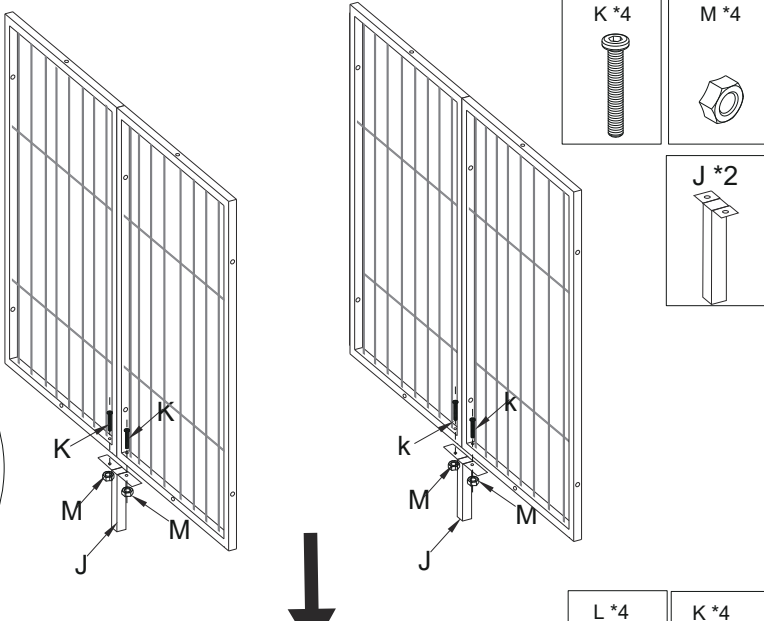
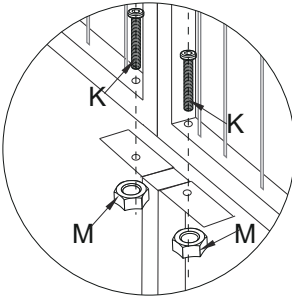

4

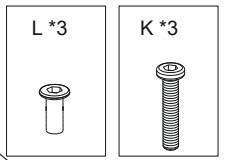
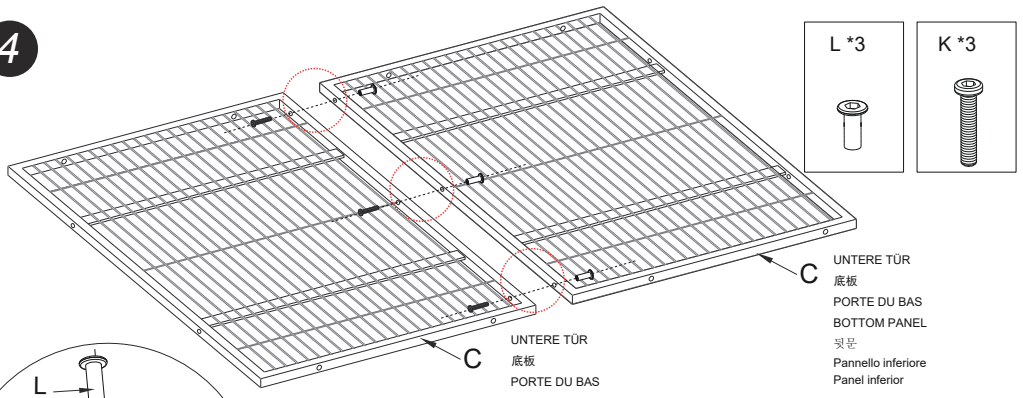
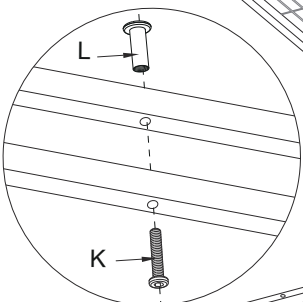

UNTERE TÜR
 底板
 PORTE DU BAS
 BOTTOM PANEL
 底板
 Pannello inferiore
 Panel inferior

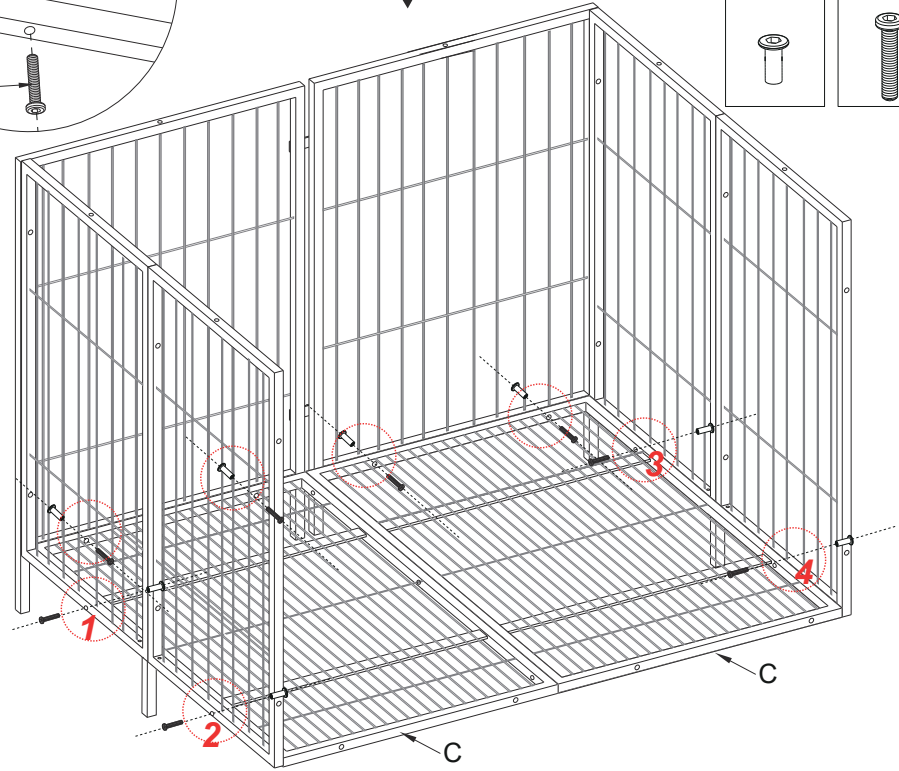
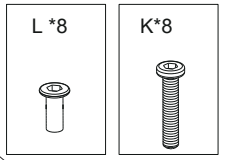

INSTALLIEREN SIE ZUERST DIE VIER ECKEN GEMÄß DER SERIENNUMMER
 上図のように、1~4の順に板をそれぞれ取り付けてください
 INSTALLEZ SELON LES ÉTAPES DU NUMÉRO
 INSTALL THE SIDES FIRST ACCORDING TO THE NUMBERS
 번호에 따라 네가지 모서리를 설치하십시오.
 Come mostrato in figura, installare i pannelli secondo l'ordine ①-④
 Como se muestra en la figura, instala los paneles en el orden ①-④

5

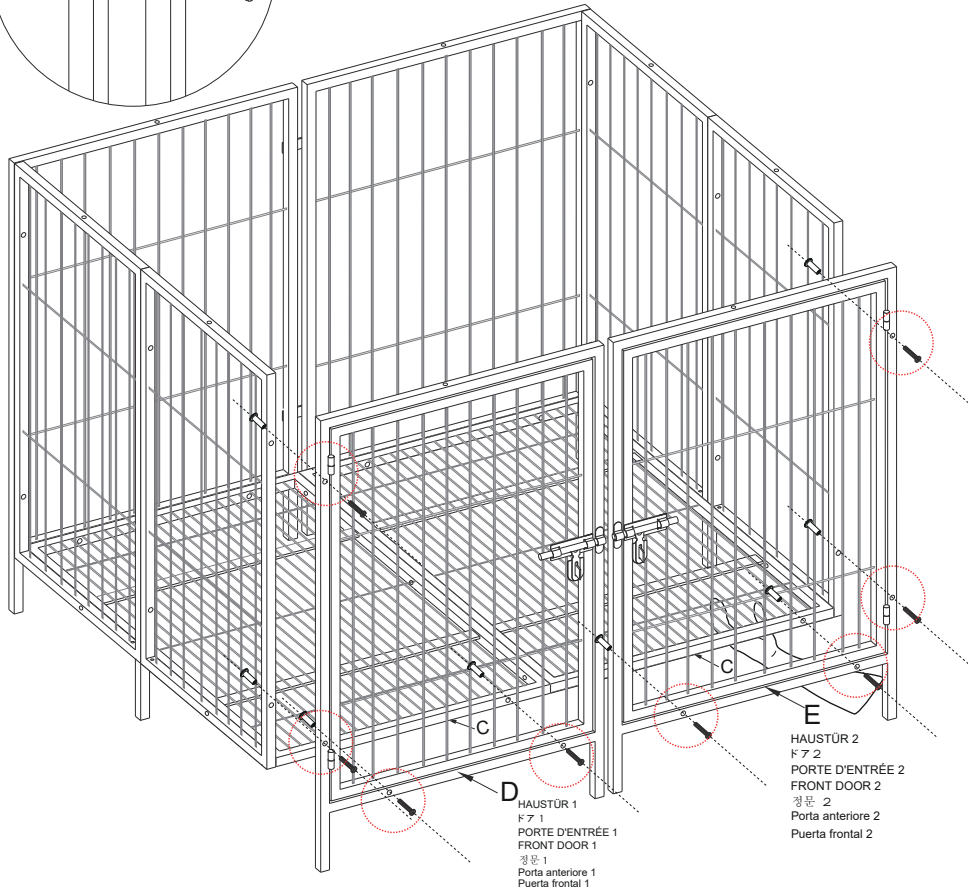
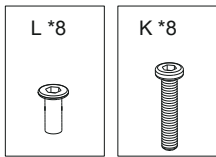
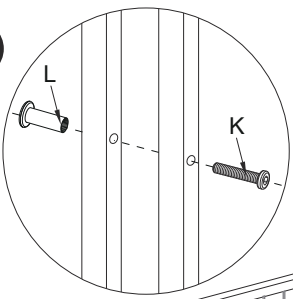

▶Attention: Please holding the C fitting with hands so as to make sure the hole positions are aligned when assembling the D and E fittings.

▶Hinweis: Bei der Montage der Teile D und E bitte Teil C mit den Händen abstützen, um sicherzustellen, dass die Löcher ausgerichtet sind.

▶注意: 部品Dと部品Eを取り付けるとき、ネジ穴を合わせるため、手で部品Cを支えてください。

▶Remarque: Lors de l'installation des pièces D et E, veuillez soutenir la pièce C avec vos mains pour vous assurer que les trous sont alignés.

▶주의하세요: D, E 부품을 설치할 때 C와 구멍을 맞춘 후 진행하십시오.

▶Nota: durante l'assemblaggio dei componenti D ed E, sorreggere il componente C con la mano per allineare i fori.

▶Nota: Durante el ensamblaje de los componentes D y E, sostén el componente C con la mano para alinear los orificios.

6

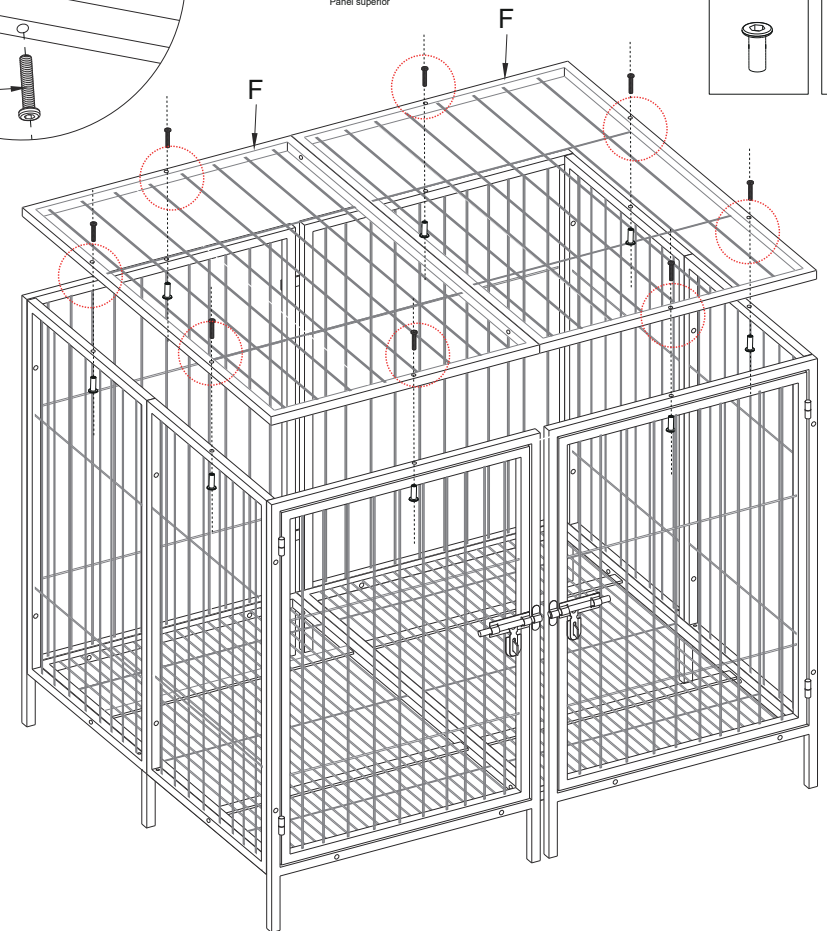
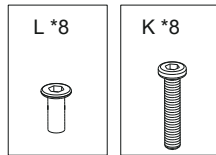
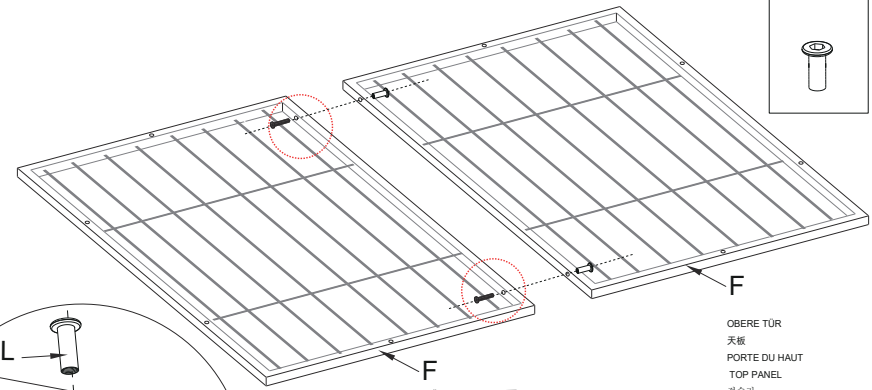
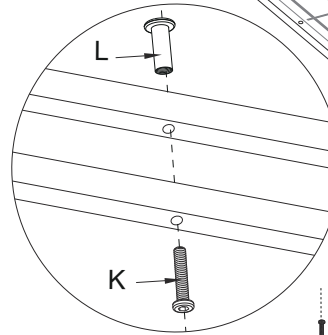
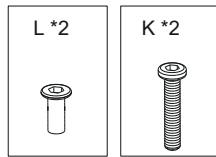

7

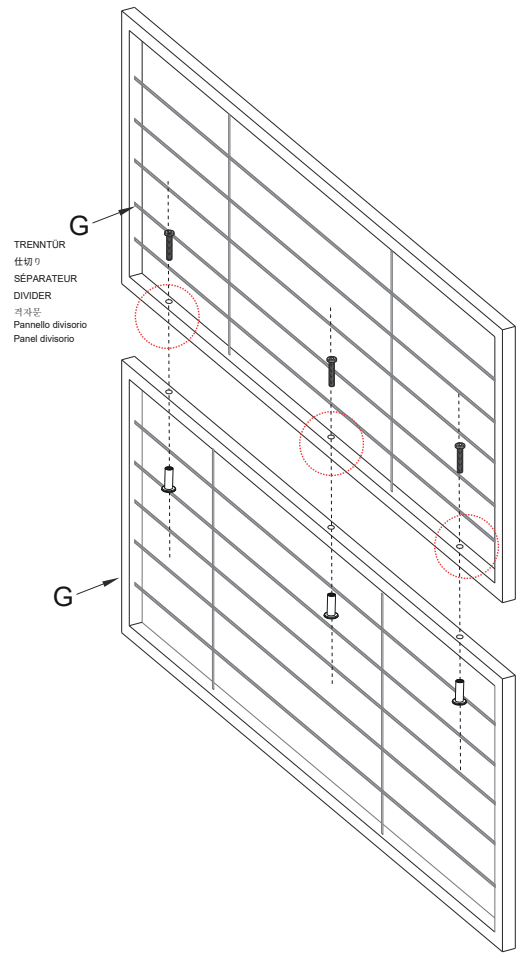
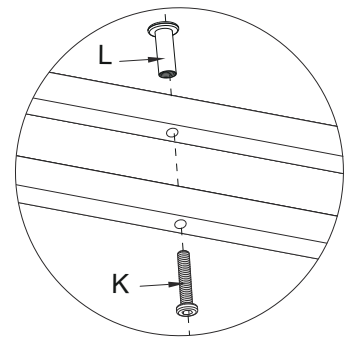
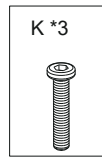
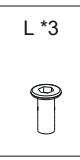

8

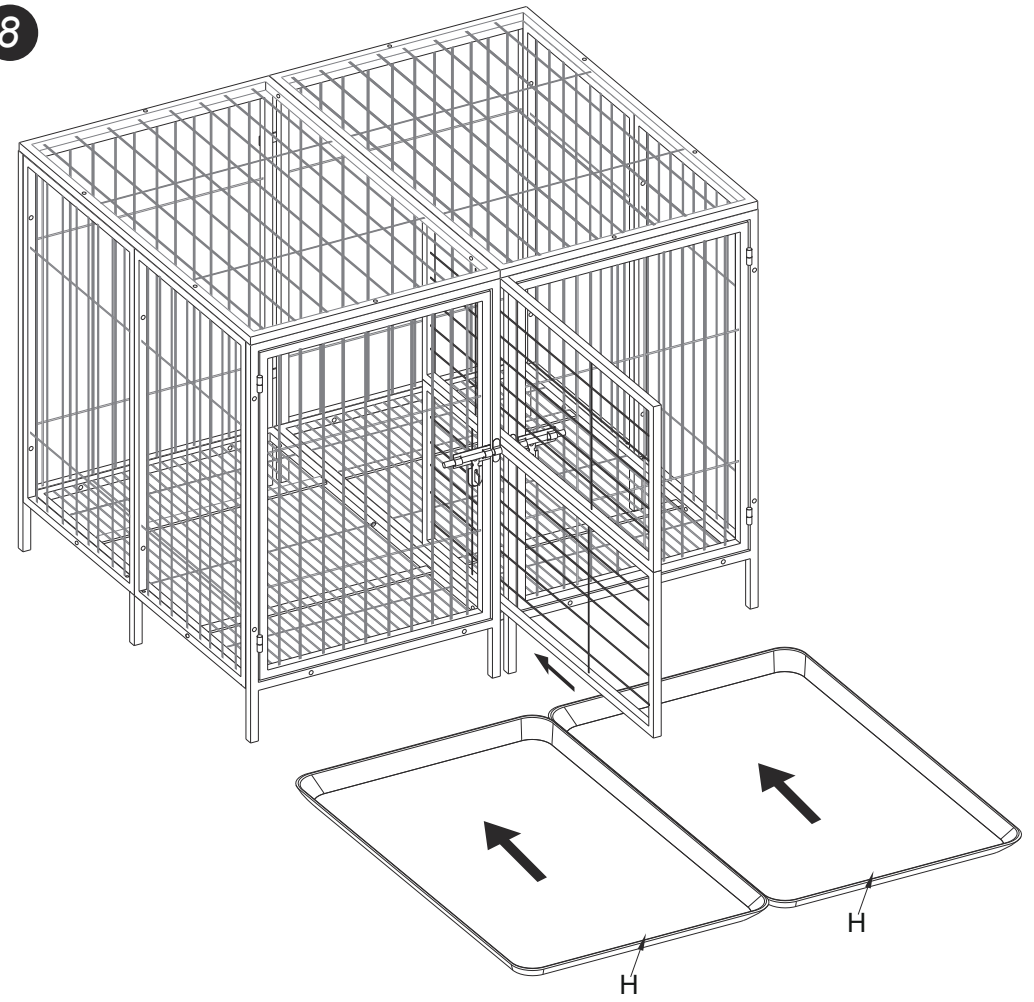

- ▶ Please place some toys to comfort the pets if they can't get used to the cage at first.
- ▶ Haustiere können sich zunächst nicht daran gewöhnen. Bitte bereiten Sie Spielzeug vor, um den Hund zu trösten.
- ▶ 注意：ペットの匂いや飼い主さんの匂いが付いているタオルや玩具などを中に入れておくと、安心して使ってくれるようになるかもしれません。
- ▶ Si les chiens ne peuvent pas s'y habituer dans le cage au début, veuillez préparer des jouets pour les reconforter.
- ▶ 주의：애완동물 냄새나 주인 냄새가 묻어 있는 수건이나 장난감 등을 안에 넣어두면 애완동물에게 안심감을 주고 사용해 줄 수도 있습니다.
- ▶ Se il tuo animale domestico non si adatta immediatamente alla gabbia, prova a mettere alcuni giocattoli per confortarlo.
- ▶ Si tu mascota no se adapta de inmediato a la jaula, intenta poner algunos juguetes para consolarla.