

NOTE:

This brochure contains IMPORTANT safety info. Please read and keep for future reference.

MAINTENANCE AND WARNING

- 1.Keep furniture away from heat sources.
- 2.Do not clean furniture with harsh cleaner or polishes.Do not use detergents,solvents,abrasives,spray packs or leather cleaner. Use non-color mild soa with warm water to clean spills(Mix 1:10 soap to water).
- 3.Do not place furniture under direct sunlight,material will possibly fade over time.
- 4.Do not use on site dry cleaning machine.Children should not climb or jump on the furniture.
- 5.Do not write on furniture that is not protectedby a padded barrier.
- 6.Not for commercial use,only for residential use.



Weight Limitation

40 LBS



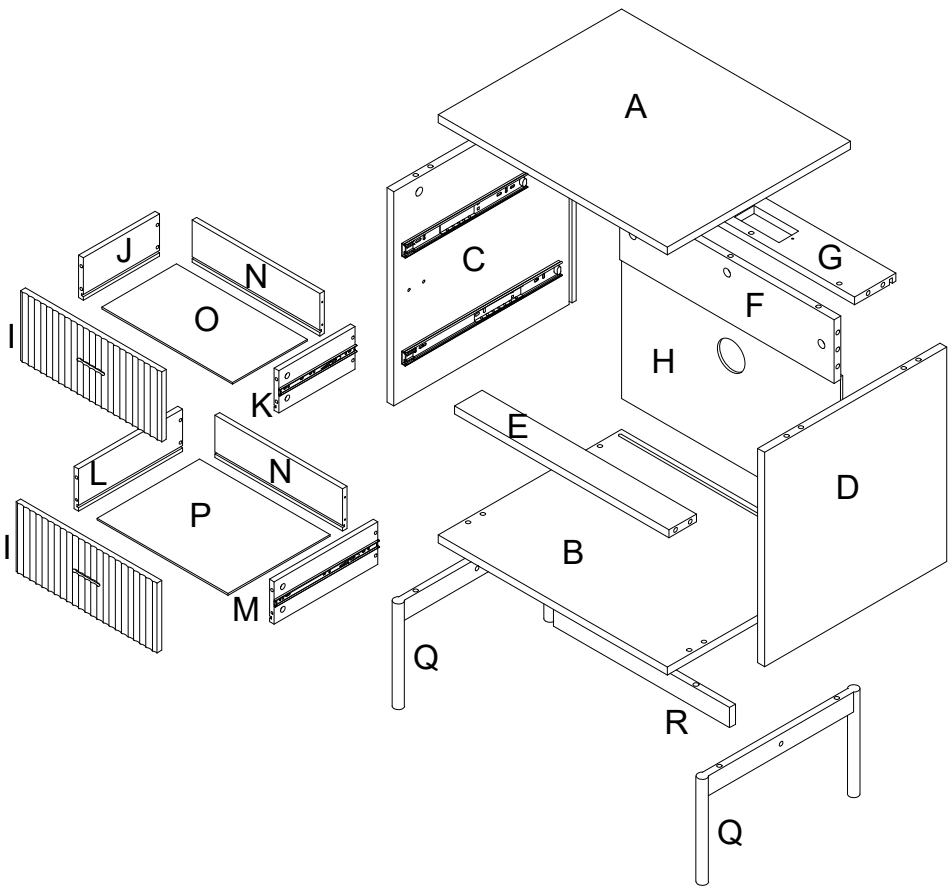



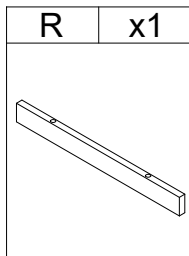
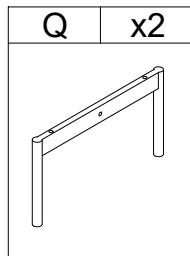
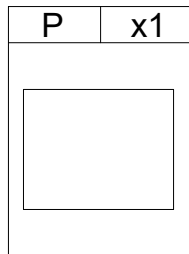
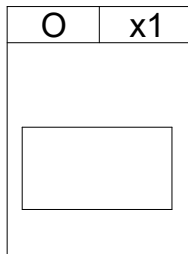
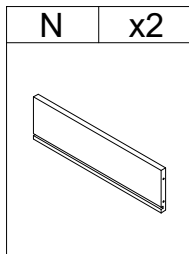
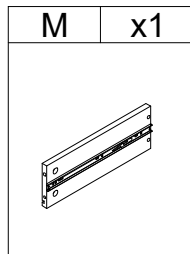
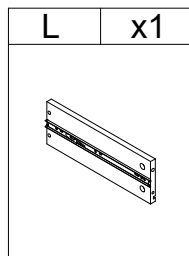
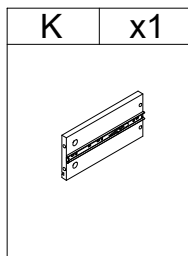
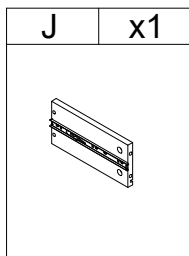
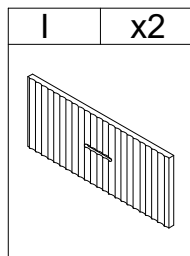
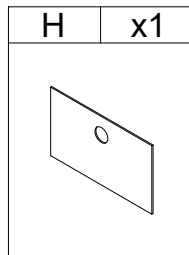
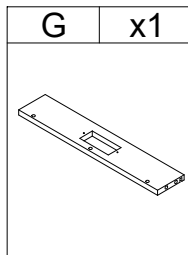
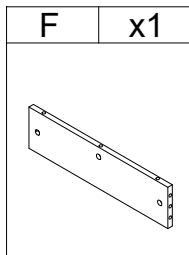
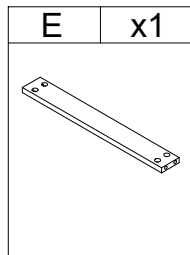
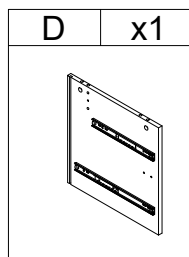
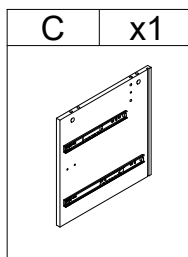
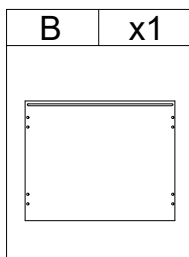
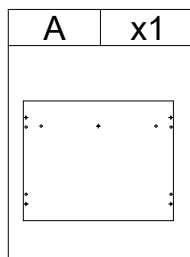



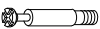





EXPLOSIVE VIEW





PARTS LIST



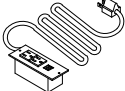



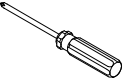

HARDWARE LIST

#1	x21	#2	x21	#3	x4	#4	x16	#5	x8	#6	x4
											
M6*35mm		Ø15mm		M7*50mm		Ø8*30mm		Ø3.5*14mm			
#7	x13	#8	x1	#9	x2	#10	x2	#11	x2	#12	x6
											
Ø4*35mm								M6*35mm		M6*50mm	
#13	x6	#14	x21	#15	x4	#16	x2	#17	x1		
											
Ø13*Ø6.5*1											

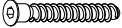
TOOL LIST

#19	x1	#20	x1
			
		M4	

HARDWARE SPARE LIST

#1	x2	#3	x1	#5	x1	#7	x1	#11	x1
									
M6*35mm		M7*50mm		Ø3.5*14mm		Ø4*35mm		M6*40mm	
#12	x1	#15	x1						
									
M6*50mm									

ASSEMBLY INSTRUCTIONS

STEP-1

1. Insert bolt #1 into the corresponding hole of drawer front(I), tighten bolt #1 with screwdriver #19.

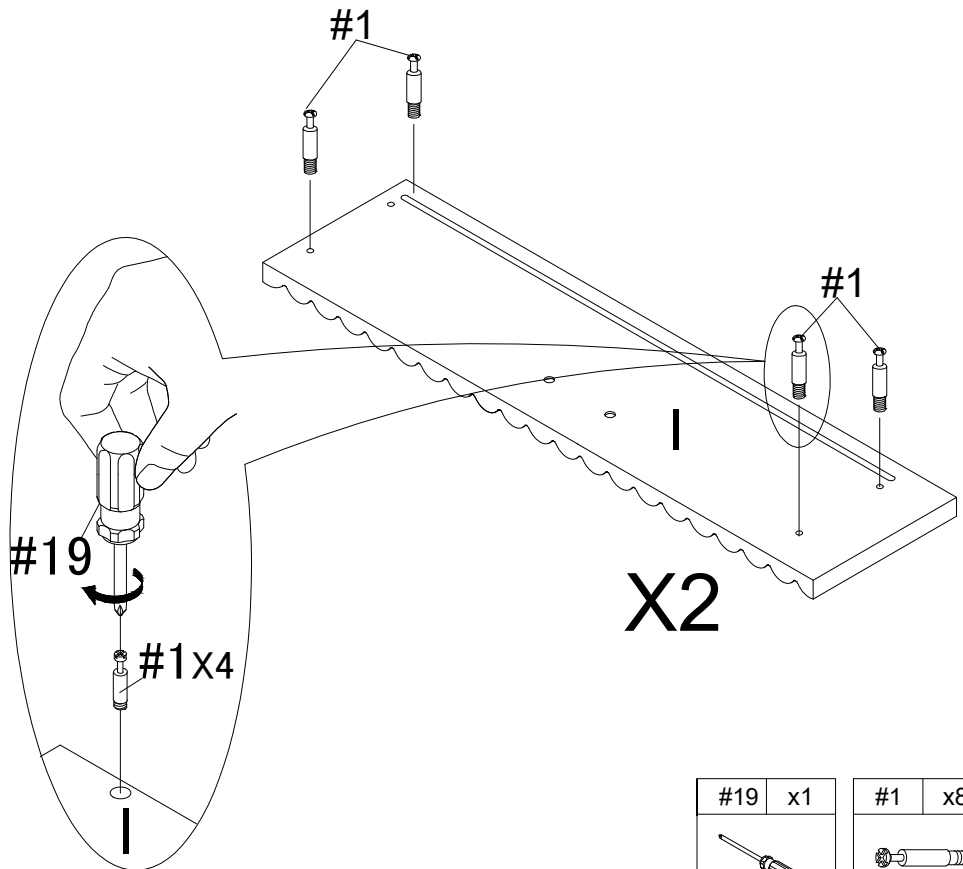

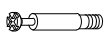
#19	x1	#1	x8
			
		M6*35mm	



ASSEMBLY INSTRUCTIONS

STEP-2

Use bolt #7 to attach drawer side (K) & (J) to drawer back (N), tighten bolt #7 with screwdriver #19, and slide in the part O into the groove in part J, K. make sure they are also in groove in part N.

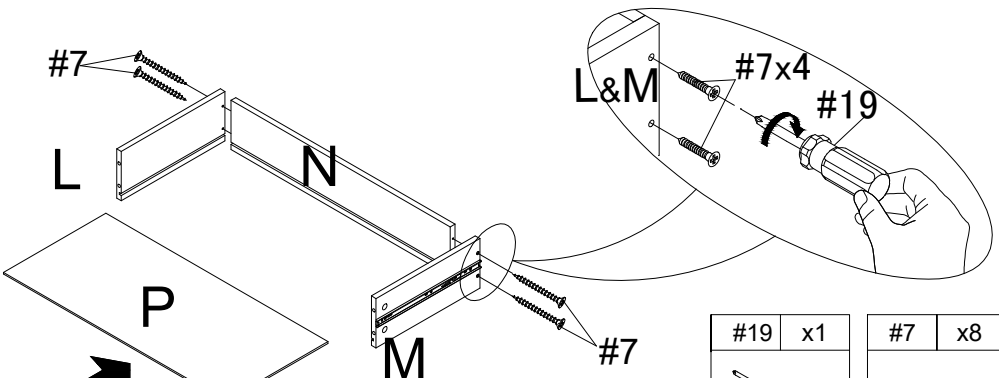
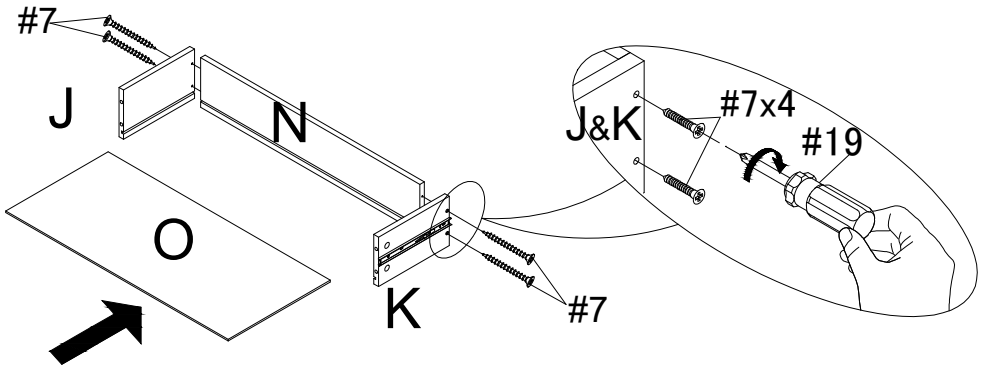
Use bolt #7 to attach drawer side (L) & (M) to drawer back (N), tighten bolt #7 with screwdriver #19, and slide in the part P into the groove in part L, M. make sure they are also in groove in part N.



#19	x1	#7	x8
			
ø4*35mm			

ASSEMBLY INSTRUCTIONS

STEP-3

Insert drawer front (I) into preassembly step 2, make sure all holes aligned and insert cam bolt #2 into the corresponding hole of drawer side panel K&J&L&M, tighten cam bolt #2 with screwdriver #19. after installation, cover the screw holes with #14.

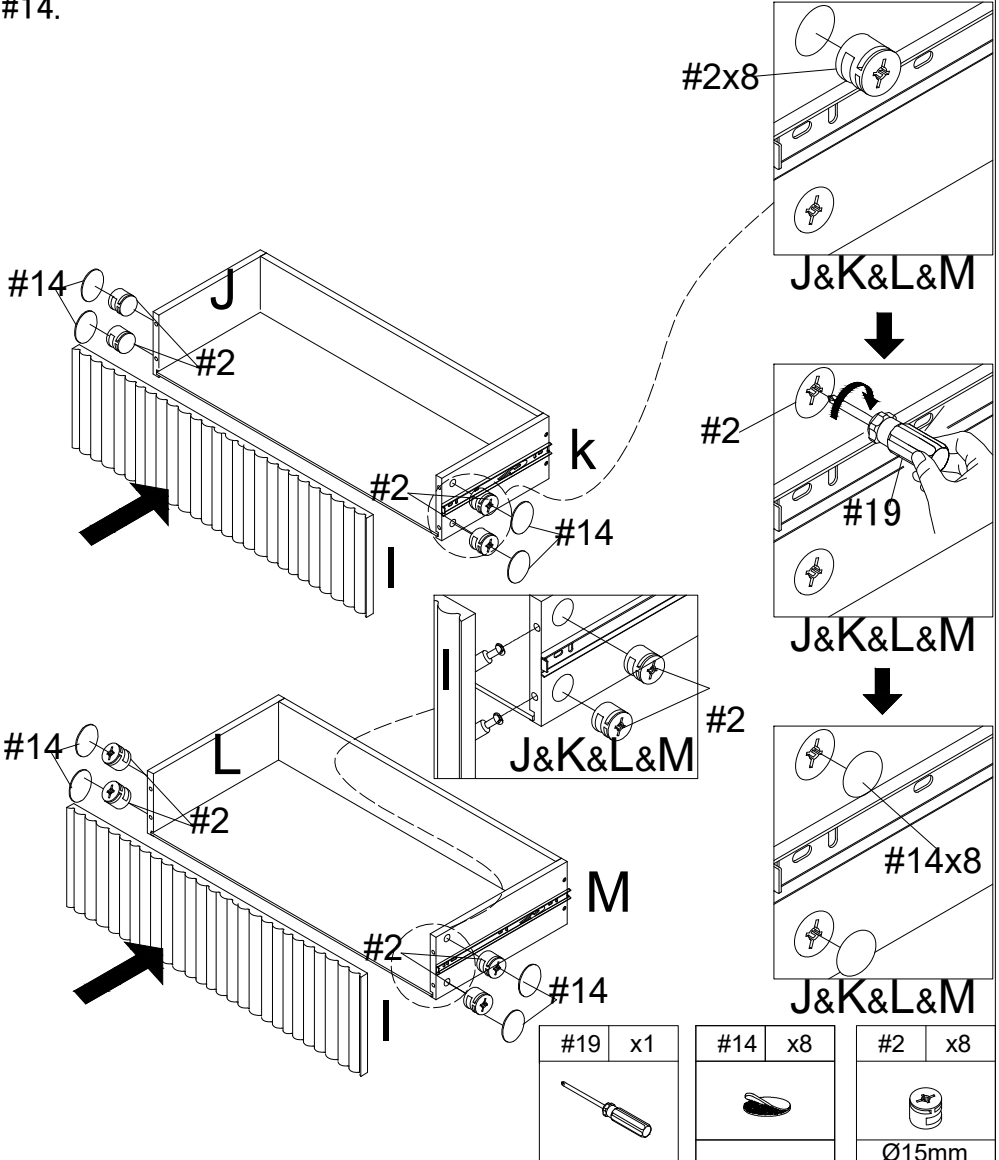



ASSEMBLY INSTRUCTIONS

STEP-4

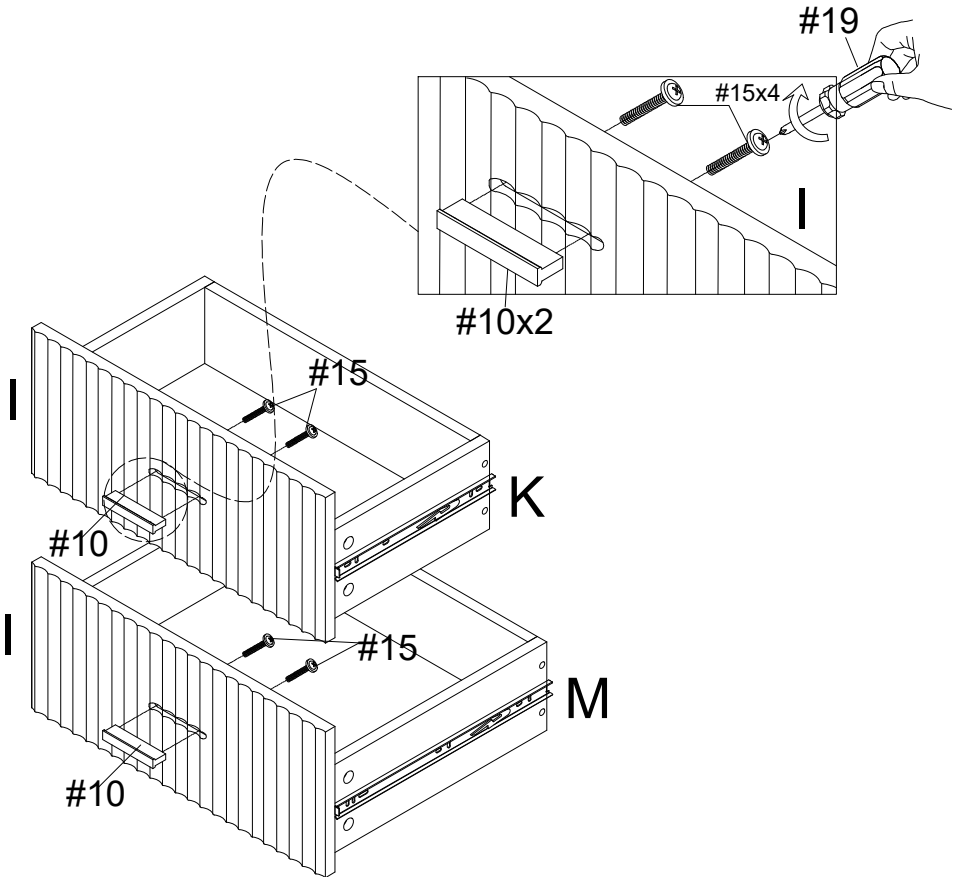
Use bolt #15 to attach handle #10 to drawer front (I), tighten bolts #15 with screwdriver #19.







#19	x1	#15	x4	#10	x2
					

ASSEMBLY INSTRUCTIONS

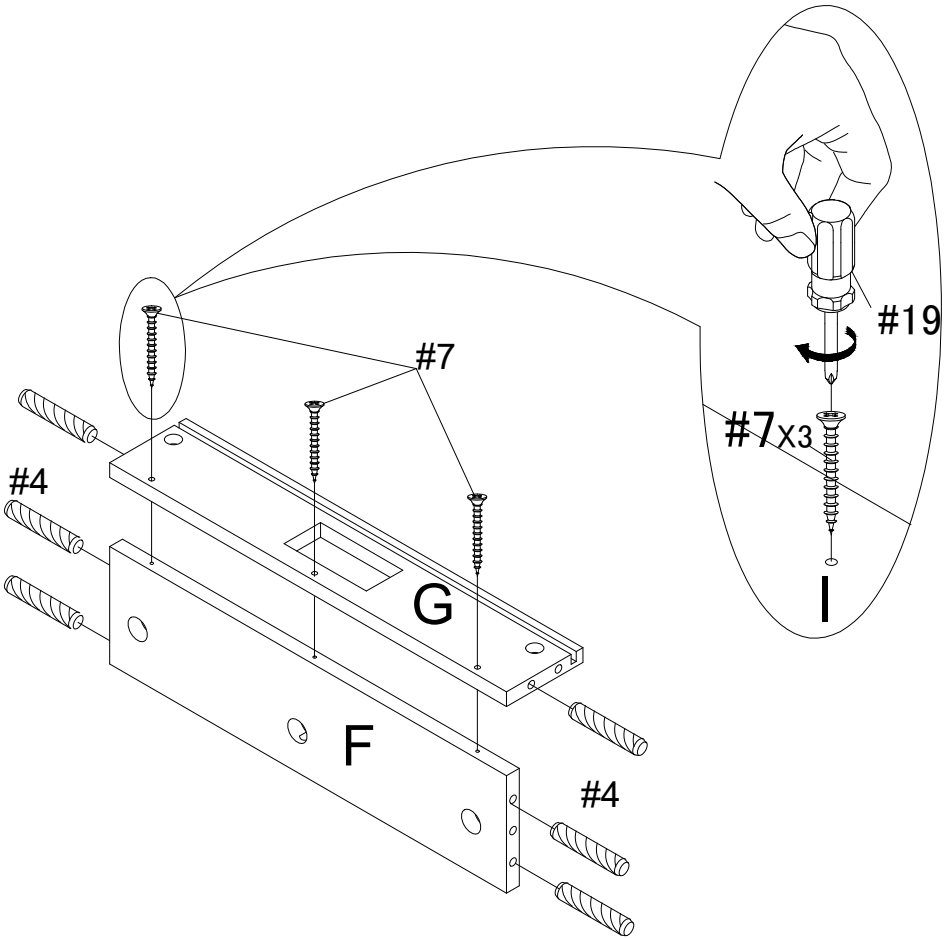
STEP-5

Align the holes of the G part with the holes of the F part, insert the screw #7, and tighten the screw #7 with the screwdriver #19. and insert wooden dowel #4 by hand.





#19	x1	#4	x6	#7	x3
					
		Ø8*30mm		Ø4*35mm	

ASSEMBLY INSTRUCTIONS

STEP-6

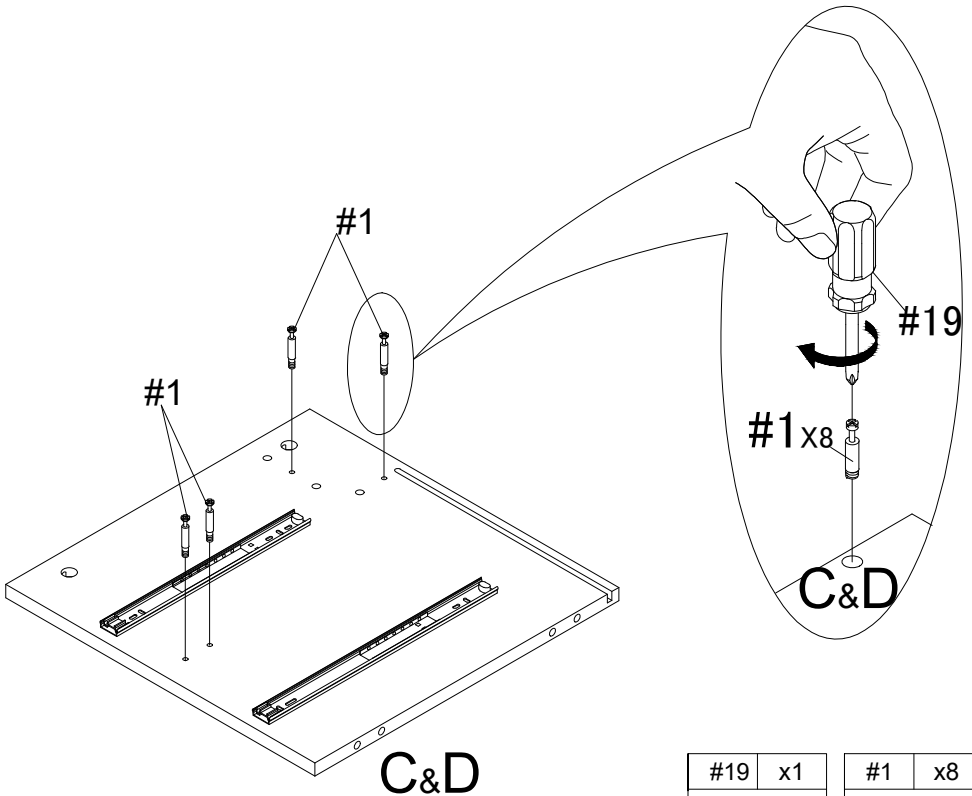
Insert bolt #1 into the corresponding hole of side panel(C&D), tighten bolt #1 with screwdriver #19.



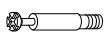



#19	x1	#1	x8
			
		M6*35mm	

ASSEMBLY INSTRUCTIONS

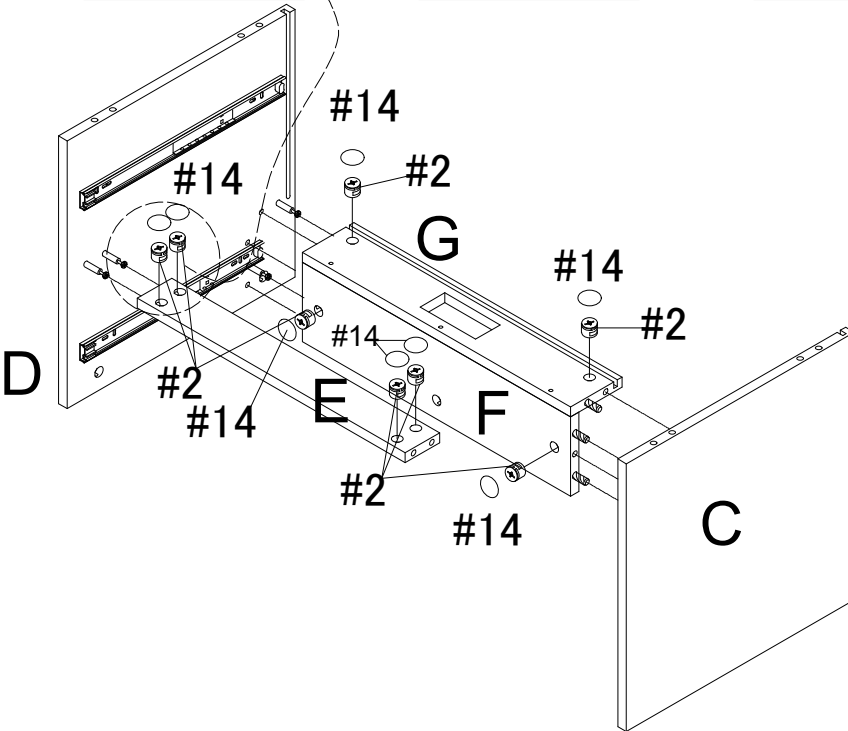
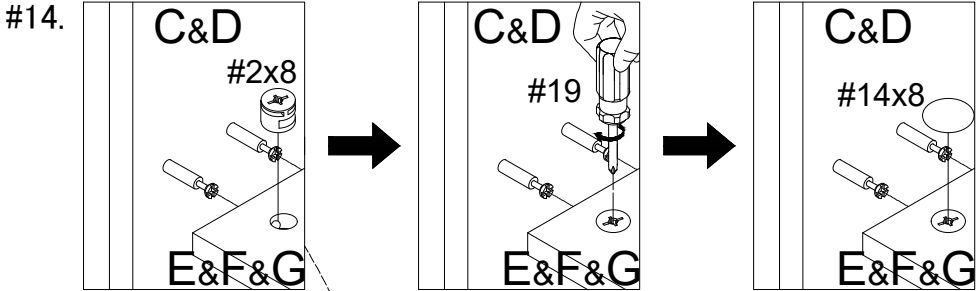
STEP-7

Insert the parts (G&F&E) into the side panels (C&D), make sure all holes aligned and insert cam bolt #2 into the corresponding hole of panel (E&F&G), tighten cam bolt #2 with screwdriver #19. after installation, cover the screw holes with #14.





#19	x1	#2	x8	#14	x8
					
		Ø15mm			

ASSEMBLY INSTRUCTIONS

STEP-8

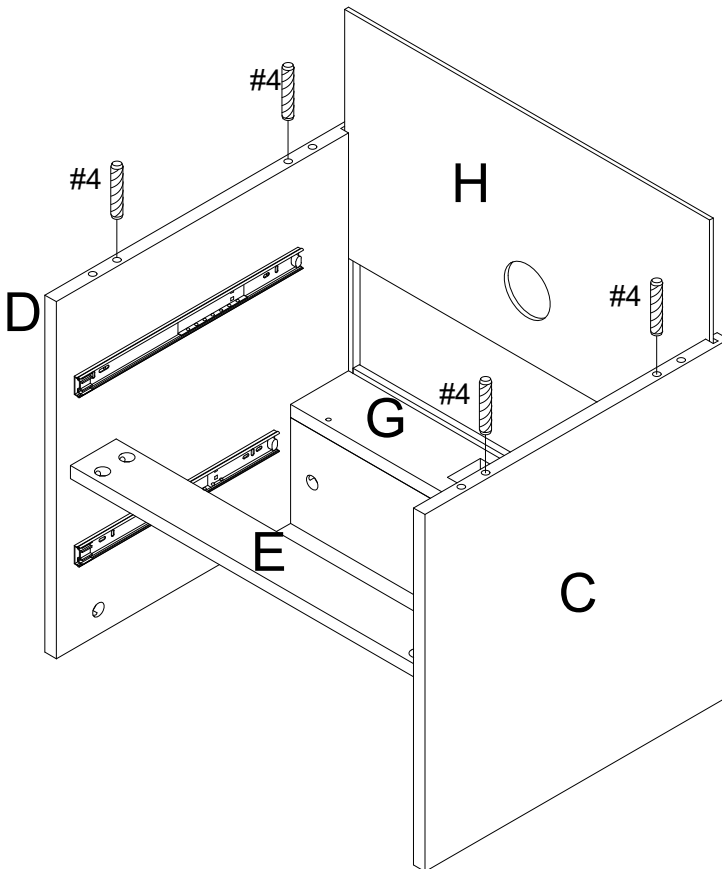
slide in the part (H) into the groove in part (C&D) . make sure they are also in groove in part G.And insert wooden pin #4 to side panel C&D by hand.





#4	x4
	
Ø8*30mm	

ASSEMBLY INSTRUCTIONS

STEP-9

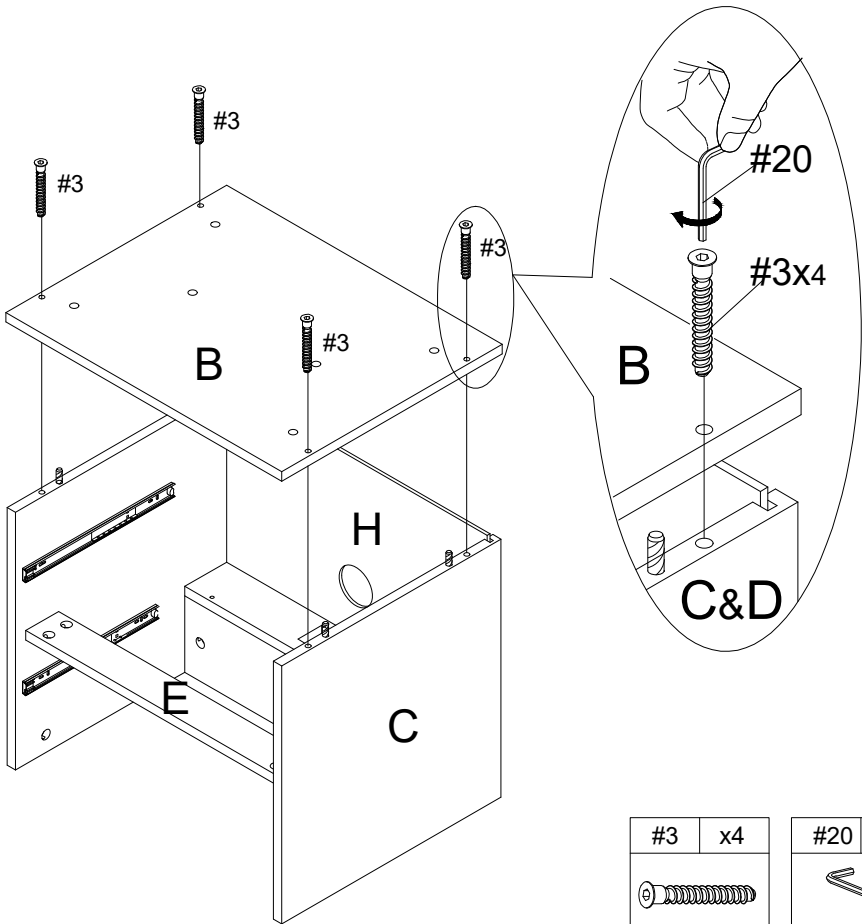
Then align the holes in part B, Insert screw #3 and push it down so that it connects to parts (C&D&H). Next, and tighten the screw #3 with an Allen key #20.





#3	x4	#20	x1
			
M7*50mm		M4	

ASSEMBLY INSTRUCTIONS

STEP-10

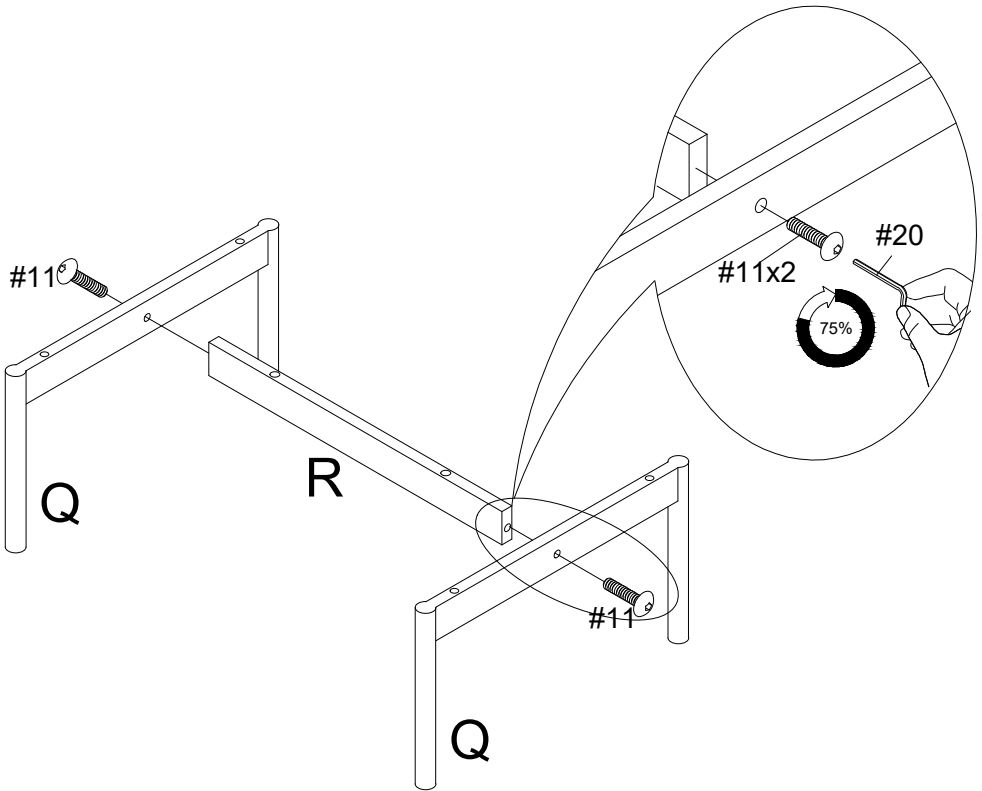
Prepare the leg racks. Align the holes of the Q part with the holes of the R part, insert the screw #11, and tighten the screw #11 with the allen key #20.





#11	x2	#20	x1
			
M6*35mm		M4	

ASSEMBLY INSTRUCTIONS

STEP-11

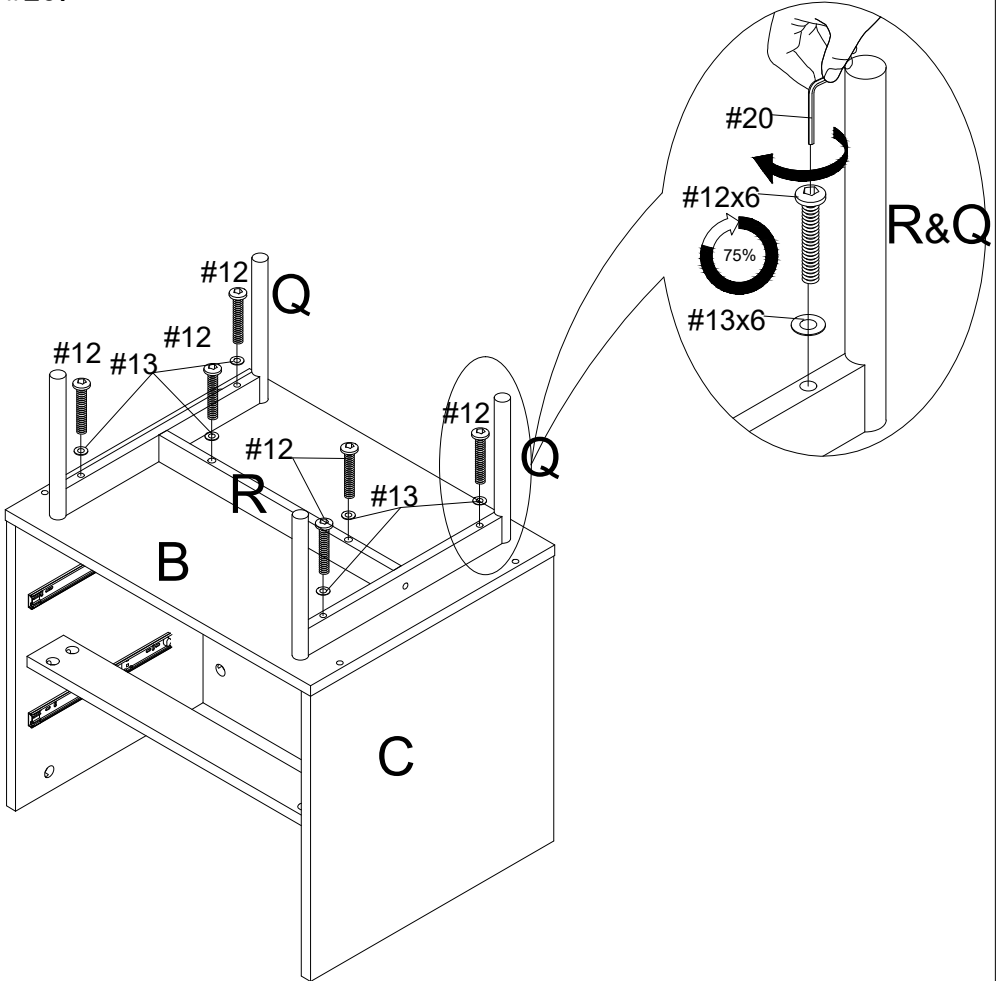
Insert gasket #13 into bolt #12, connect the leg frame to the cabinet. Attach the leg frame to the pre-assembled unit in step 9 with a screw #12 and tighten #12 with a allen key #20.



#13	x6
	
Ø13*Ø6.5*1	

#12	x6
	
M6*50mm	

#20	x1
	
M4	

ASSEMBLY INSTRUCTIONS

STEP-12

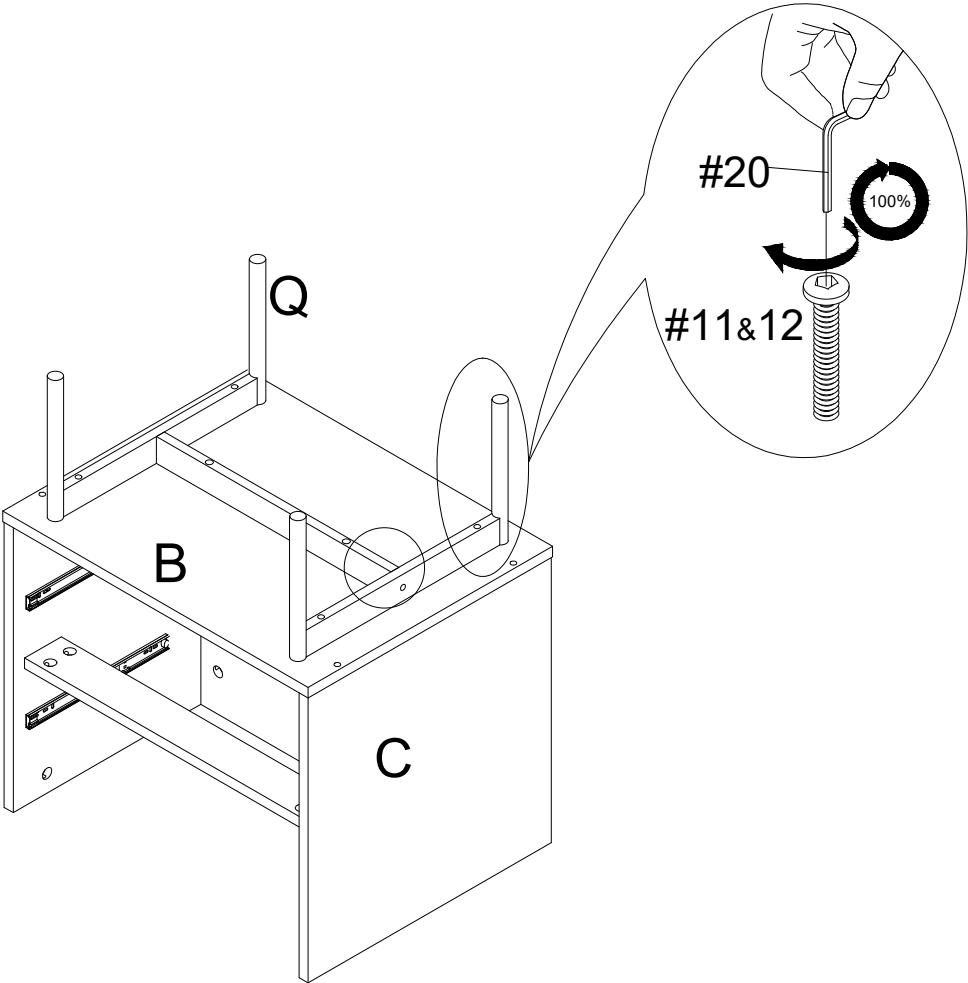



ASSEMBLY INSTRUCTIONS

STEP-13

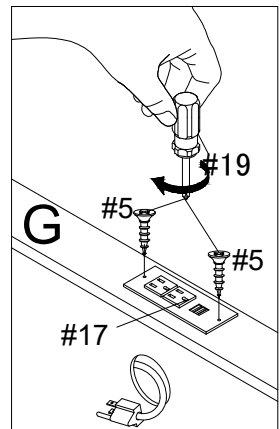
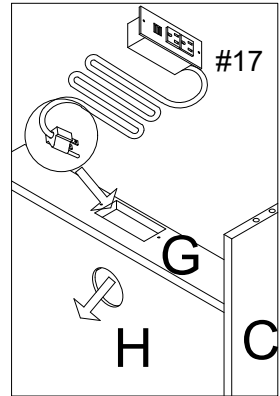
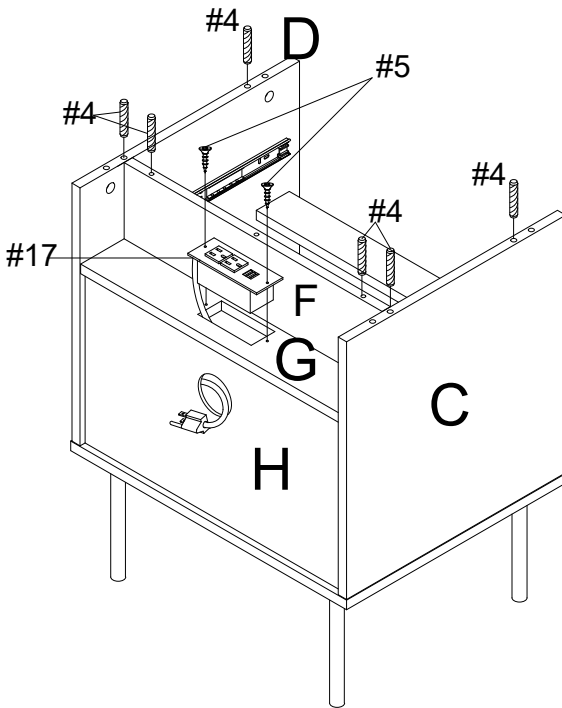
Insert wooden pin #4 to side panel (C&D&F) by hand. Connect socket #17 to part G using screw #5. and tighten it with screwdriver #19.



#19	x1
	

#4	x6
	
Ø8*30mm	

#5	x2
	
Ø3.5*14mm	

#17	x1
	

ASSEMBLY INSTRUCTIONS

STEP-14

Insert bolt #1 into the corresponding hole of top panel (A), tighten bolt #1 with screwdriver #19.

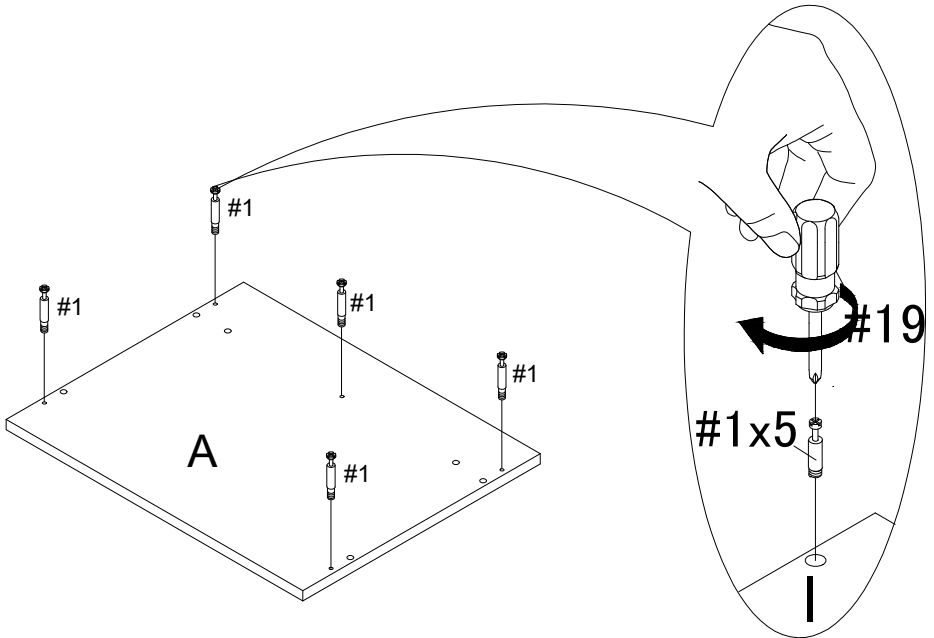

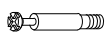

#19	x1	#1	x5
			
		M6*35mm	

ASSEMBLY INSTRUCTIONS

STEP-15

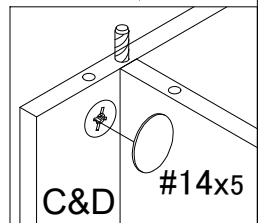
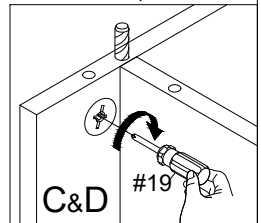
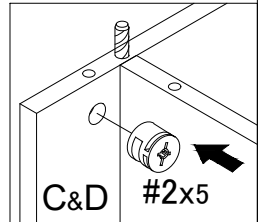
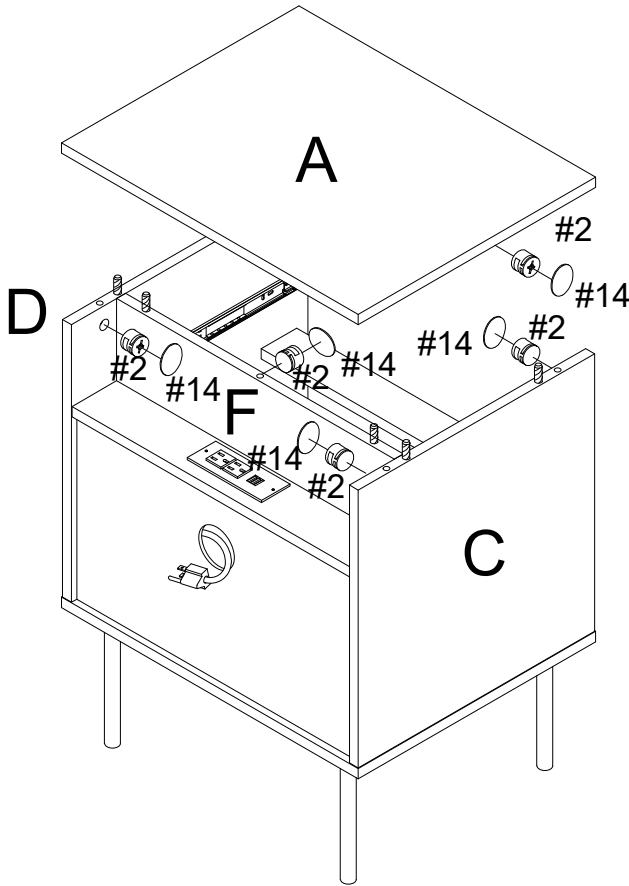
Insert the top panel (A) into the side panels (C&D&F), make sure all holes aligned and insert cam bolt #2 into the corresponding hole of panel (C&D&F), tighten cam bolt #2 with screwdriver #19. after installation, cover the screw holes with #14.



#19	x1
	

#14	x5
	

#2	x5
	
Ø15mm	





ASSEMBLY INSTRUCTIONS

STEP-16

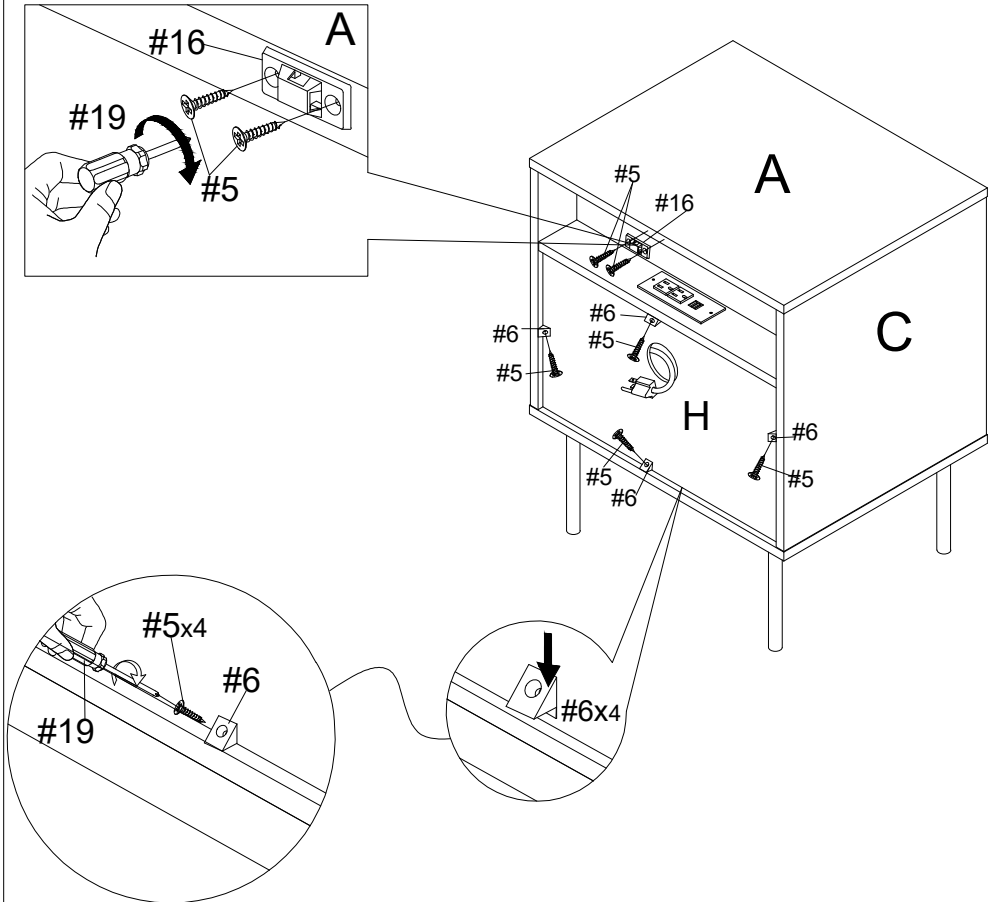
Use screw #5 to attach plastic bracket #16 to panel (A), make sure all holes aligned and tighten screw #5 with screwdriver #19

Insert hardware #6 into part H as shown, screw in screw #5 using screwdriver #19 and tighten fully.



#19	x1	#16	x1	#5	x6	#6	x4
							
				Ø3.5*14mm			

ASSEMBLY INSTRUCTIONS

STEP-17

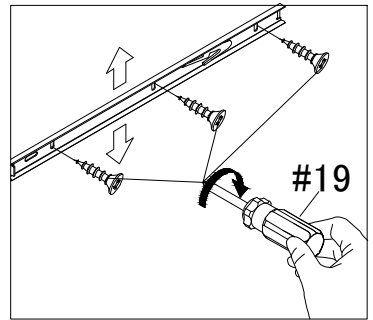
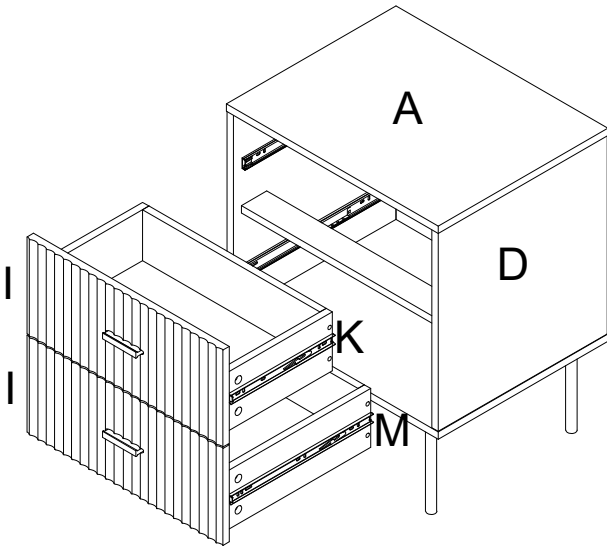

Slide rail adjustment
legend !!!

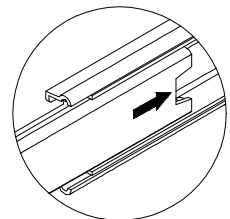
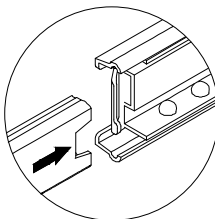
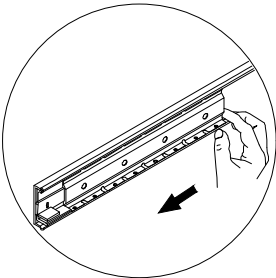

ASSEMBLY INSTRUCTIONS

STEP-18





Mark the position on the wall, that corresponds to the location of part #16 on the top panel A; Drill and insert the expandable screw #9 by hammer.

Assemble the part #16 to the wall. Align the hole in the part #16 with the expandable screw #9, use screw #7 to attach it and tighten by screwdriver 19.

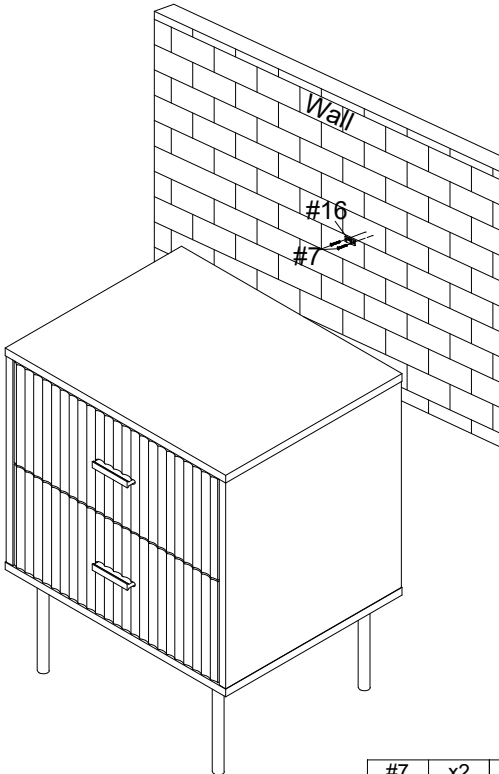
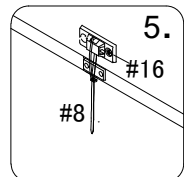
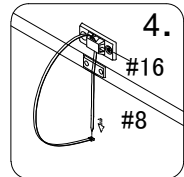
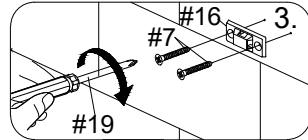
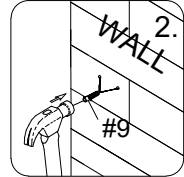
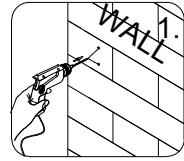
Let the plastic belt #8 pass through the both part #16 and pull tightly.

NOT PROVIDED

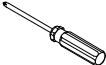

#7	x2	#8	x1	#9	x2	#16	x1	#19	x1
									
M4x35mm									

WARRANTY

1. We strive to offer high-quality products, and we also try our best to satisfy each and every customer that orders from us with product or service as needed.
2. We provide 30 days warranty starting from the time you receive the item. Each customer must provide a record of their order such as the order number, or item receipt for any items that are out of the warranty period you may also still receive.
3. Replacement parts by purchasing them with our company if they are available.