

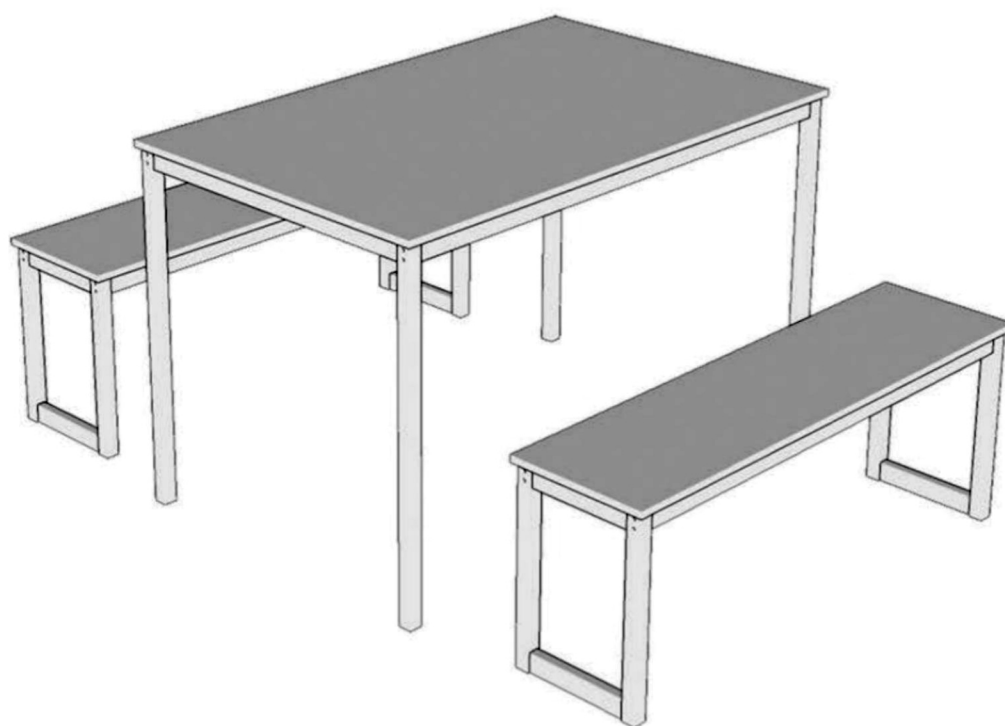

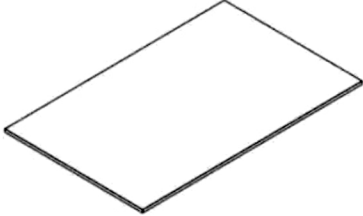

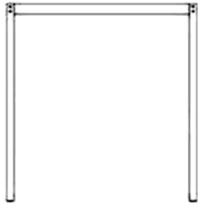

Assembly Instruction



PART LIST

| | | |
|---|--|-----|
| A |  | x1 |
| B |  | x2 |
| C |  | x2 |
| D |  | x2 |
| E |  | x4 |
| F |  | x4 |
| ① |  (M6x50) | x36 |
| ② |  (M6x35) | x6 |
| ③ |  | x1 |
| ④ |  | x4 |

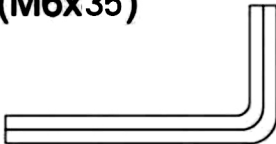
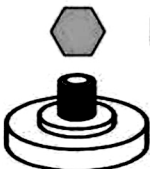
● Weight Capacity for Table: 100 LBS

● Weight Capacity for Each Bench: 300 LBS

1

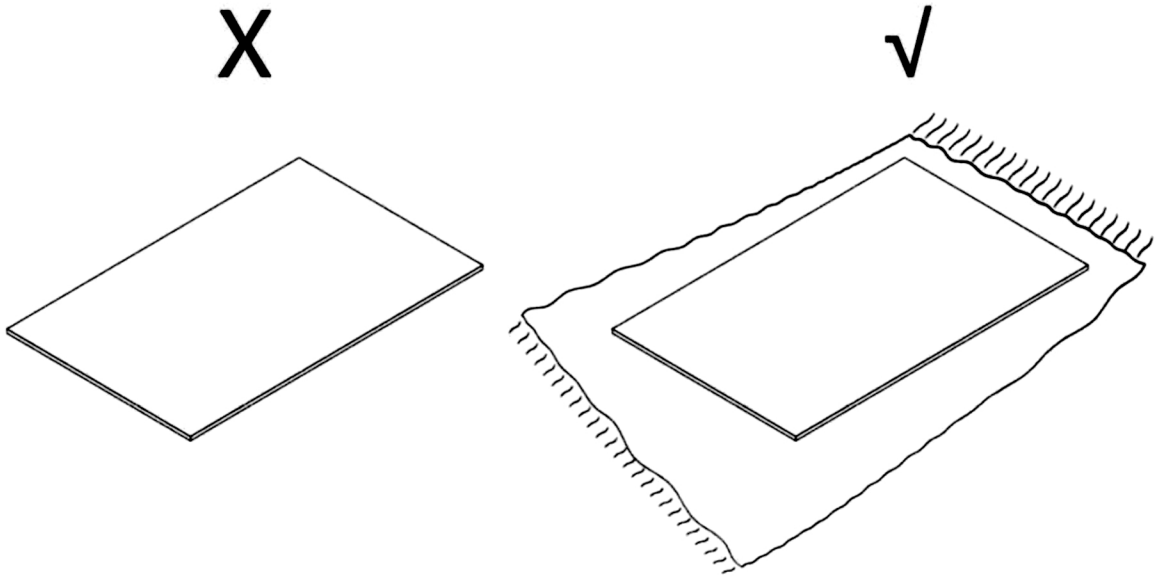

- Please put the tabletop on a smooth surface for assembly in case of accidental scratches.

2

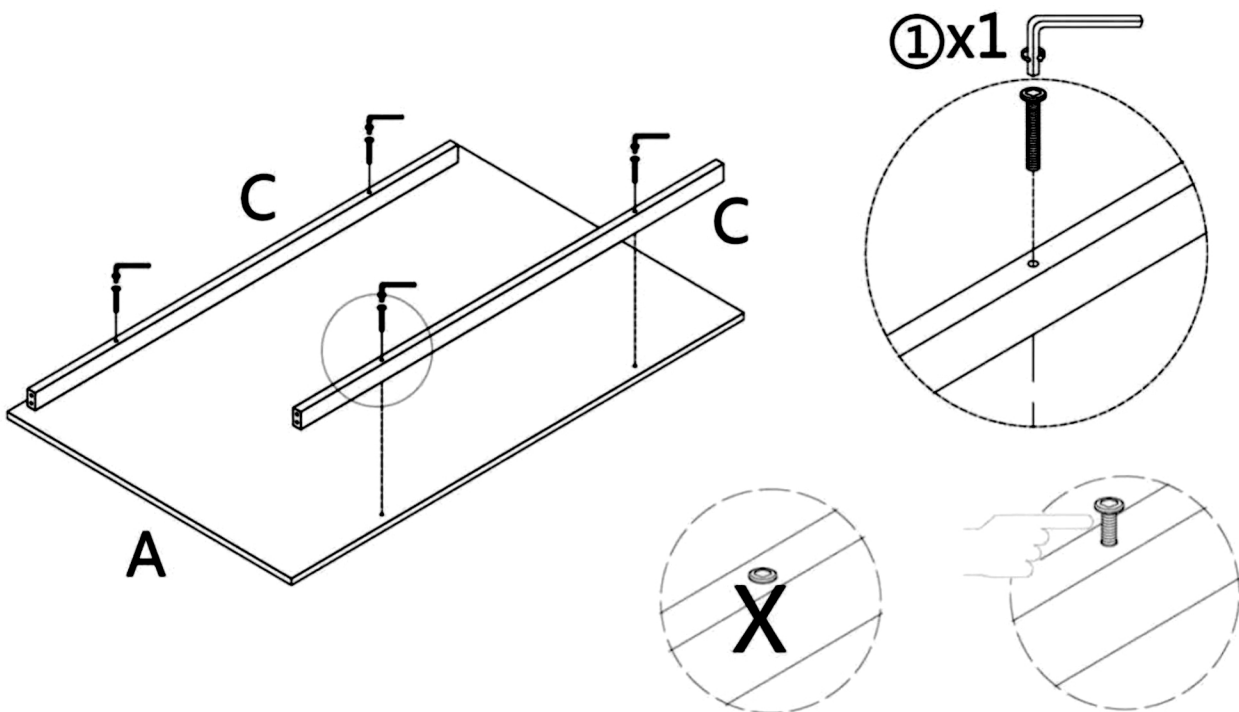

- Do not fully tighten the screws.

2

3

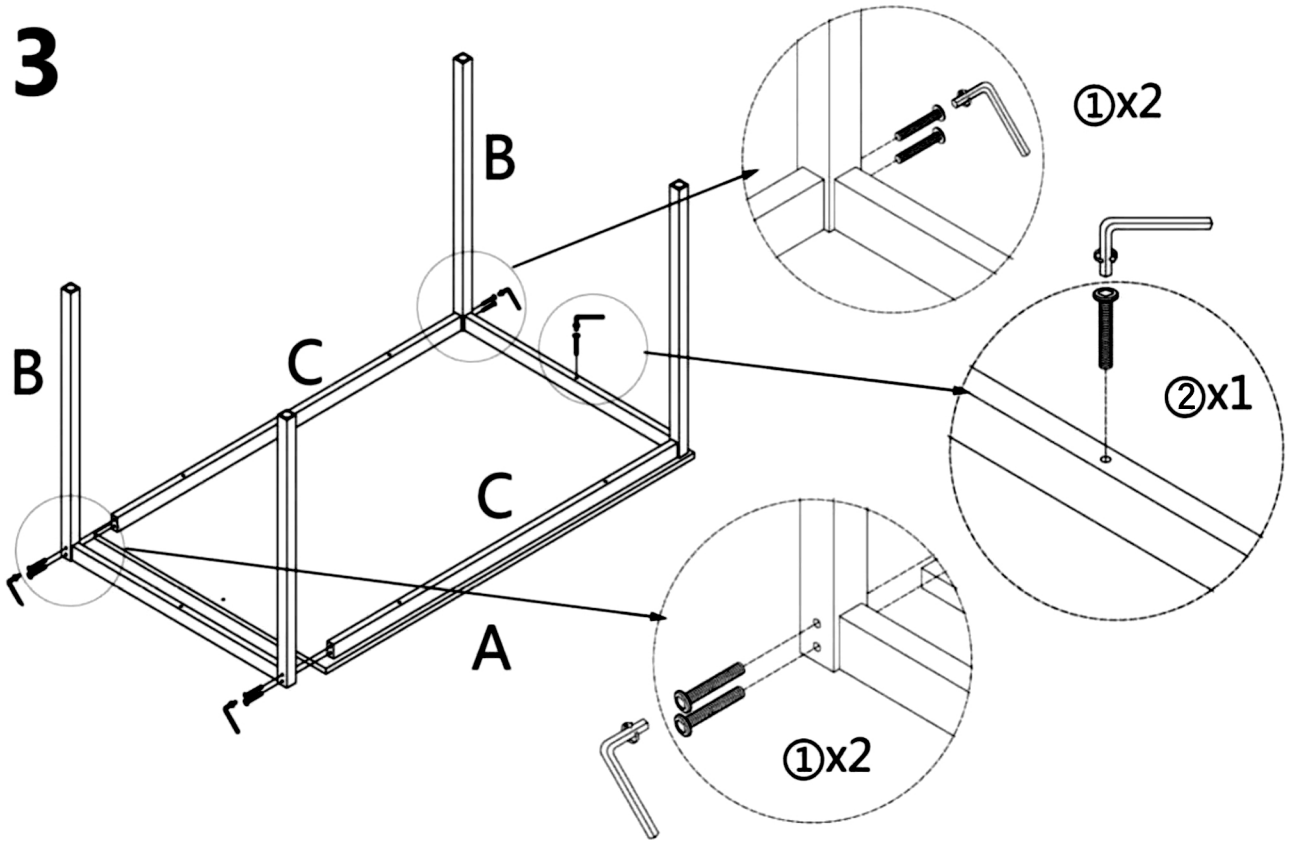

4

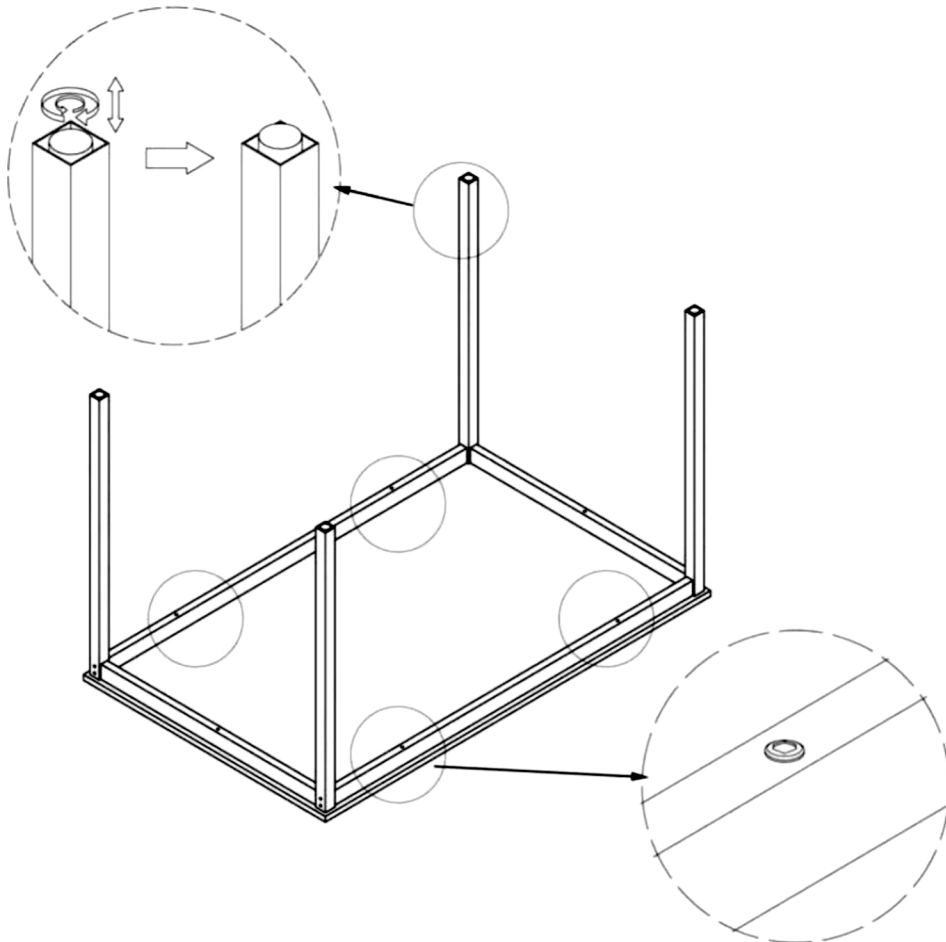

● Fully Tighten the screws. **3**

5

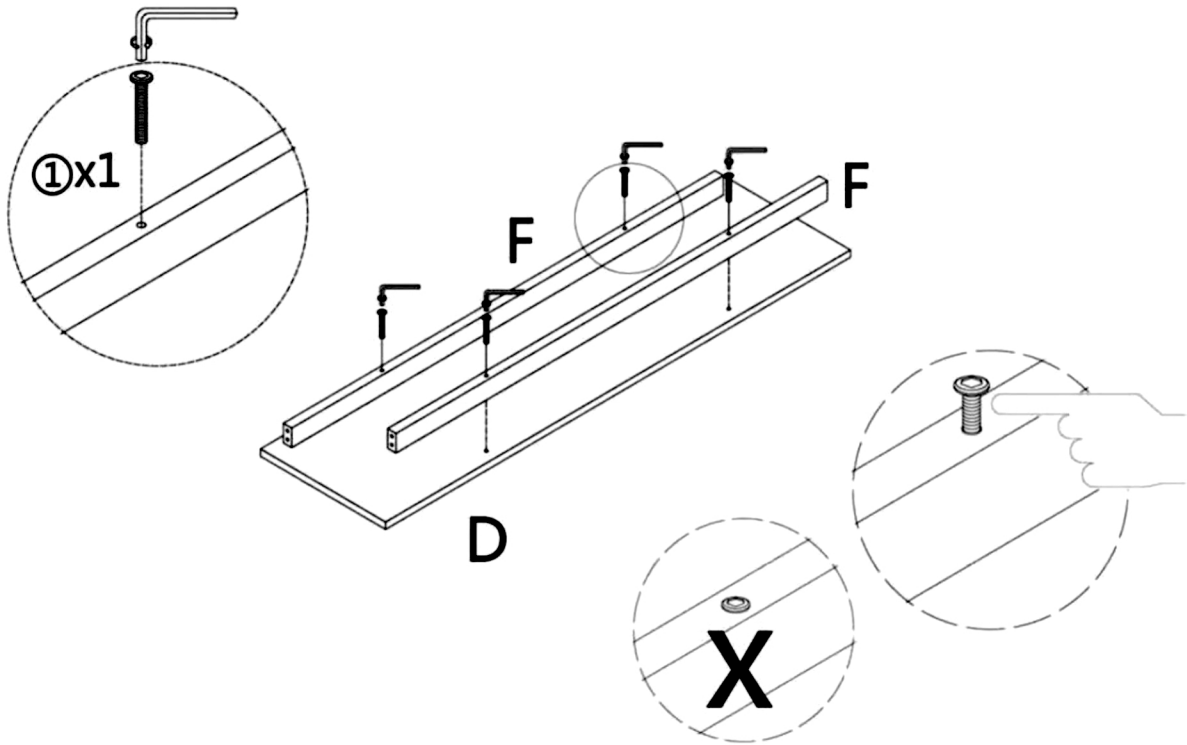

●Do not fully tighten the screws.

6

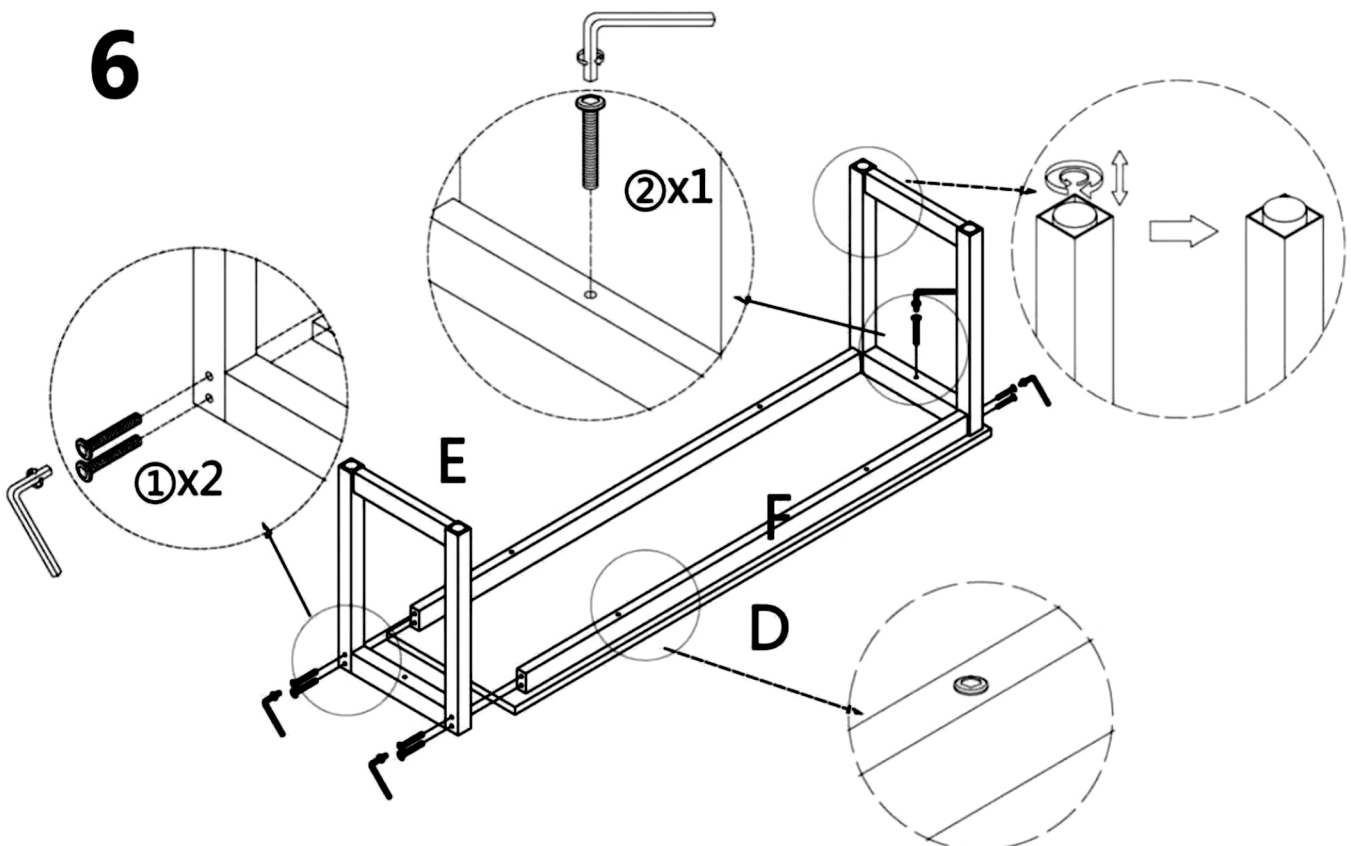

●Fully Tighten the screws.