

L A **Z** B O Y[®]
Live life Comfortably.

ASSEMBLY
Instructions

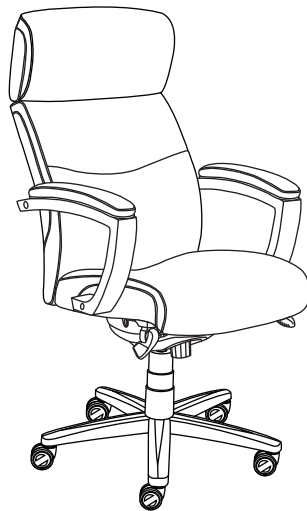

Executive Chair

Model: CHR10086A-C

Should you prefer to
speak with a customer
service representative,
you may call toll free :

1-855-372-2315 U.S. 6am - 5pm PST,
0-800-051-6775 U.K. 2pm - 1am

Guidelines

FAILURE TO FOLLOW THESE WARNINGS WHEN IN USE COULD RESULT IN INJURY

- Do not stand on the item or use as a step ladder.
- The piece has been tested and approved for users weighing up to 275 lbs (125kg) per seat.
- Do not use this item unless all bolts and screws are firmly secured and fastened.
- Check all bolts and screws every 90 days. As necessary tighten if any are loose.
- Lift up then move. Pushing over or dragging this product can result in an injury or cause damage to the floor and piece.

Pre-Assembly Preparation:

Please read through this instruction booklet before beginning assembly of this item.

Two adults are recommended for assembly.

- Clear out the space for assembly and lay out all parts on Parts List, extra room will allow you to easily determine if all the pieces are present.
- Save all packing materials until assembly is complete to avoid accidentally discarding smaller parts or hardware.
- Keep small parts and pieces away from children and pets until fully assembled.
- Please check for any loose screws and tighten them before you use.

WARNING : DO NOT LET CHILDREN PLAY IN OR AROUND THE UNIT DUE TO THE POSSIBLE RISK OF INJURY.

Parts List



A
Casters
Quantity: 5

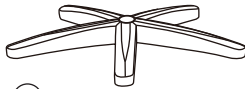

B
Star Base
Quantity: 1



C
Gas Lift with Telescoping Cover
Quantity: 1

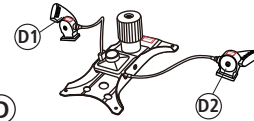

D
Seat Plate
Quantity: 1



E
Arms
Quantity: 2



F
Seat Cushion
Quantity: 1



G
Back Cushion
Quantity: 1



H
Plastic Shroud
Quantity: 1



I
1-1/2" Screws
Quantity: 2



J
1" Screws
Quantity: 2



K
1-1/4" Screws
Quantity: 4



L
2-1/2" Screws with Spring Washers
Quantity: 4



M
Plastic Caps
Quantity: 4



N
Allen Key
Quantity: 1

Step 1

Place the Star Base (B) upside down and insert 5 Casters (A) into the holes on the Star Base (B).

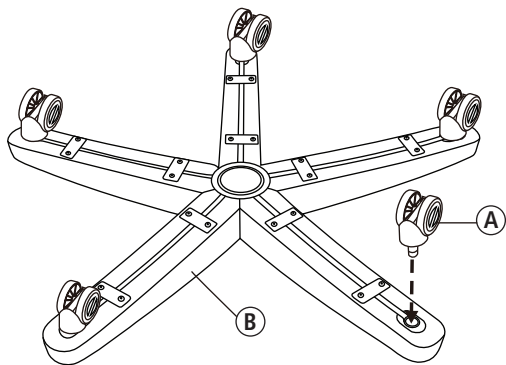

Step 2

Turn the Star Base (B) over and insert the Gas Lift with Telescoping Cover (C) through the center hole on top of Star Base (B).

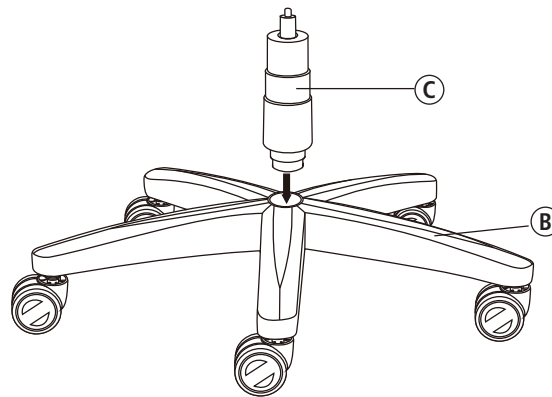

Step 3

Attach Seat Plate (D) to the bottom of the Seat Cushion (F) (with the front of the seat plate facing the front of seat cushion). Attach by using 1-1/2" Screws (I) for the front holes of the Seat Plate (D) and 1" Screws (J) for the rear holes of the Seat Plate (D) and tighten screws.

*Note: Tighten the screws completely.

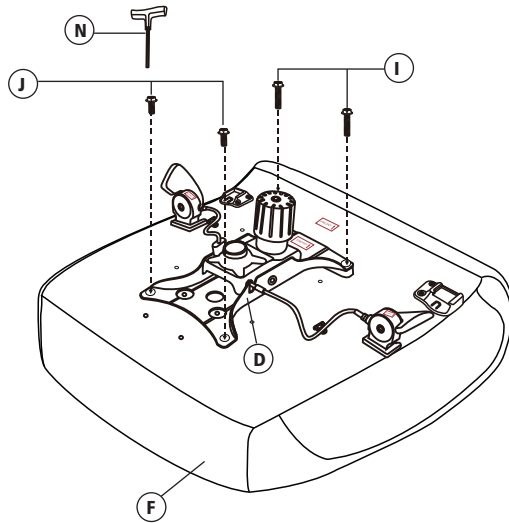

Step 4

Insert Levers (D1 & D2) of Seat Plate (D) to the pre-attached cable lever receivers on the underside of Seat Cushion (F) (with the front of the levers facing the front of seat cushion). Push down the key on the receivers to pull out the levers.

*Note: Fix the cable for the seat plate into the plastic clips attached to the bottom of the seat cushion.

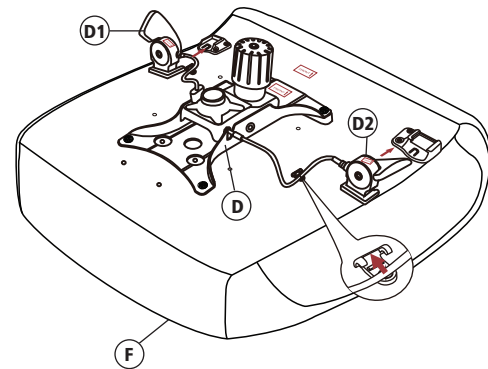
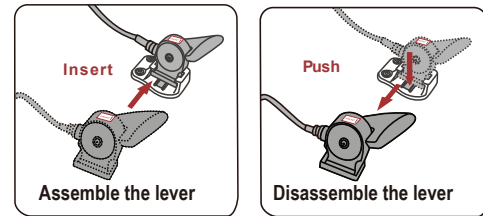

Step 5

Attach the Back Cushion (G) to the Seat Cushion (F) by positioning the back support plate over the Seat Plate (D) with 1-1/4" Screws (K).

*Note: Do not tighten the screws completely.

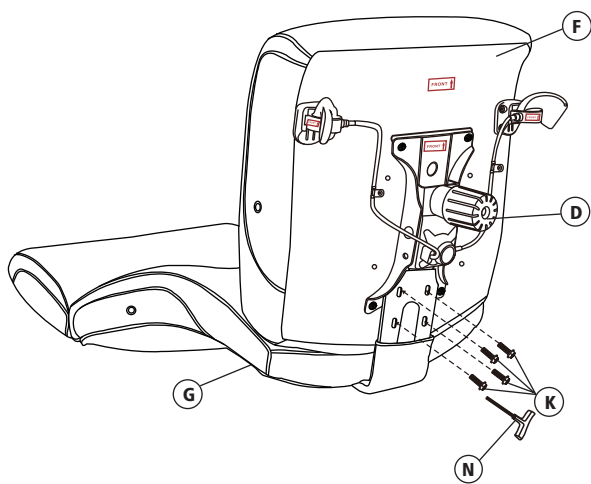

Step 6

Insert 2-1/2" Screws with Spring Washers (L) into arm holes, attaching Arms (E) (with the front of arms facing the front of seat cushion) to sides of Seat Cushion (F) and Back Cushion (G).

*Note: Tighten all the screws completely. Remember to tighten the back support plate screws.

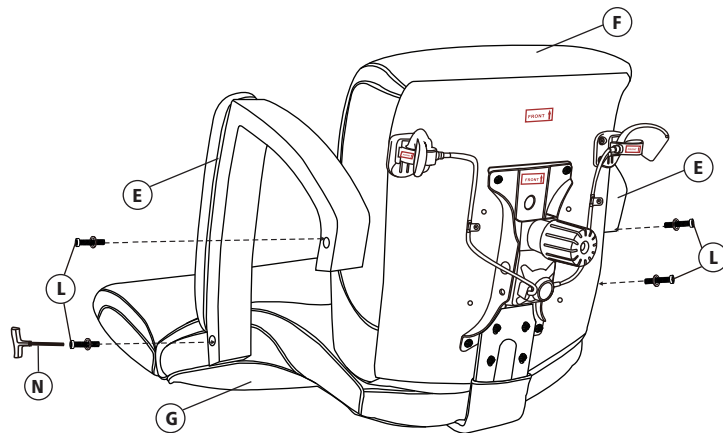

Step 7

Put the Plastic Shroud (H) over the Seat Plate (D) (with the front of plastic shroud facing the front of seat cushion). Align shroud posts to holes on bottom of Seat Cushion (F) and press into position.

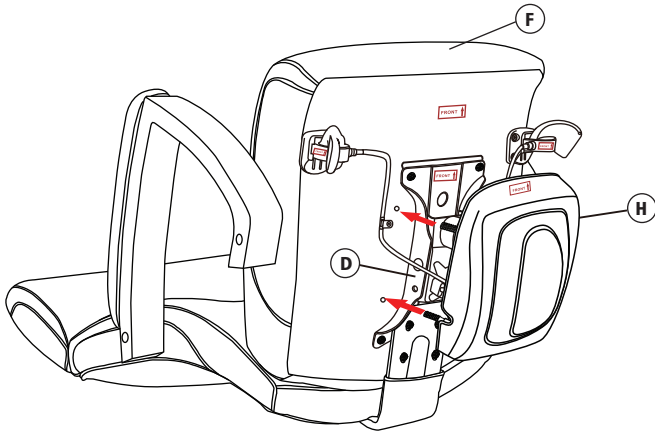

Step 8

Position the assembled chair upright with the seat plate facing down. Insert the Gas Lift with Telescoping Cover (C) into the center hole of the Seat Plate (D).

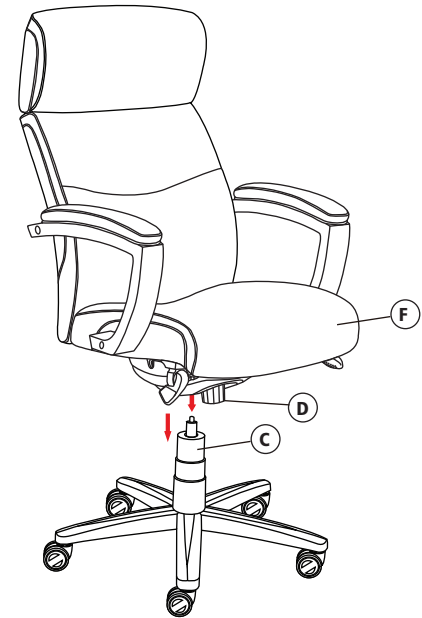

Step 9

Press the Plastic Caps (M) into armrest holes once all screws have been tightened.



Operating Instructions

Function Instruction - 1

To Adjust Seat Height:

While seated, lean forward and reach under the right side of the chair to find the lever. Lift the lever and raise your body up slightly to allow the chair to rise to the desired height. Once desired height is reached, release lever to lock chair at desired height. To lower the seat, lift the lever while seated. The chair will descend until the lever is released or the chair reaches the bottom position.

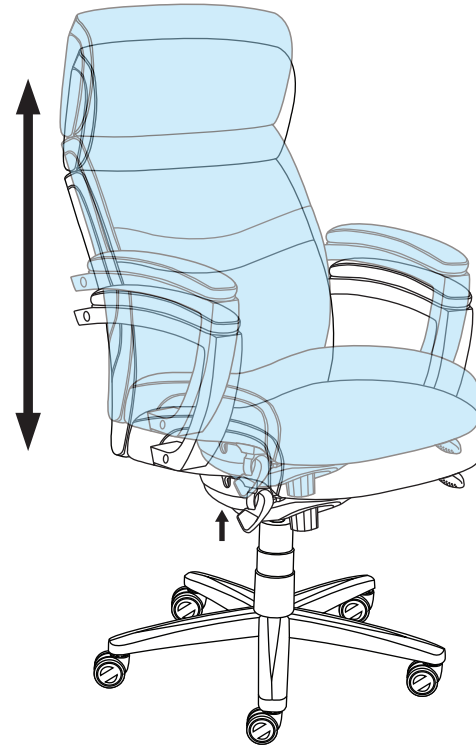

Function Instruction - 2

To Operate Tilt Lockout:

While seated, reach under the left side of the chair to find the lever. Push down the lever and lean back to allow the chair to tilt backwards. To lock the chair in the upright or vertical position, sit upright and pull the lever to the up position.

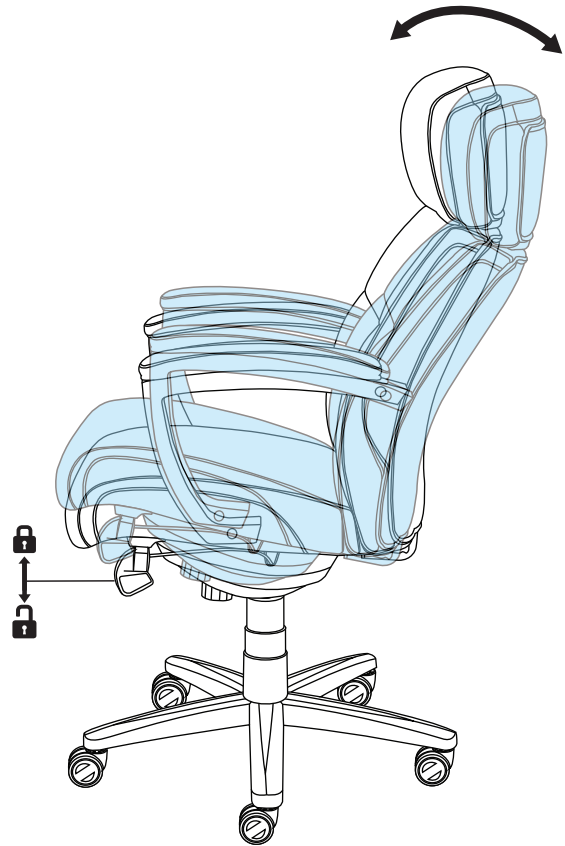

Function Instruction - 3

To Adjust Tension On The Tilt:

Reach under the front center of the chair, grasp the round knob (R) and turn it counter - clockwise to stiffen the tilt mechanism for a heavier user. Turn the knob (R) clockwise to loosen the tilt mechanism for a lighter user. Rotate the knob (R) until the desired resistance is reached.

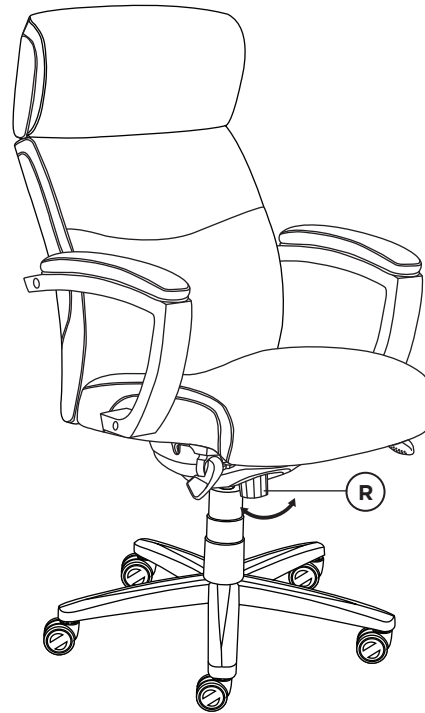

Function Instruction - 4

360° Swivel:

360° seat swivel.



Limited Warranty

The product you have purchased is warranted against defects in material and workmanship while owned by the "Original Purchaser". The term "Original Purchaser" is defined as that party or entity which purchases these products from an authorized dealer or retailer as shown by the original sales receipt. This warranty does not apply to "as is" or previously owned products.

The manufacturer warrants its products to be free from defects in materials and workmanship (normal wear and tear, fading and stretching excepted), for one year from the date of purchase, except as provided below under the limited warranty.

This warranty gives you specific rights, and you may also have other rights, which vary from state to state (or country to country). All warranties are limited to the original purchaser for normal use by a maximum of two users. Total weight capacity per chair is 275 pounds for a single user.

The exceptions or exclusions to this warranty are:

- Upholstery material and foam cushion material is warranted against defects in material and workmanship for a period of one year, beginning on the date of purchase as shown on the original sales receipt.
- Any warranty claim that is submitted after the limited warranty period, or without proper proof of purchase will not include the cost of parts, labor, or delivery on the warranted parts within a reasonable amount of time. We reserve the right to require damaged parts to be returned to us upon request. Natural markings such as scars, brands, grain variations, wrinkles, color variations, etc. will be considered normal characteristics and not construed as defects.
- For claims or questions concerning this warranty, please contact the Customer Service Department on the web at www.truecustomersupport.com. Be prepared to provide your name, address, daytime phone number, the model and purchase order number of the product, date of purchase, and the store where it was purchased. The manufacturer requires that the original sales receipt be submitted with all requests to confirm that you are the original purchaser according to our written warranty.

L A Z B O Y[®]

Live life Comfortably.[®]