

30029-LOVE SEAT ASSEMBLY INSTRUCTION

Thank you for purchasing this quality product. Be sure to check all packing material carefully for small parts which may have come loose inside the carton during shipment. Separate, identify and count all parts and hardware. Compare with the parts list to be sure all parts are present.

IMPORTANT : PLEASE READ INSTRUCTION BEFORE STARTING THE ASSEMBLY.

"DO NOT TIGHTEN SCREWS UNTIL COMPLETELY ASSEMBLED"

"DO NOT OVERTIGHT ANY HARDWARE"

WARNING : SMALL PARTS AND HARDWARE NOT FOR CHILDREN UNDER 3 YEARS. ADULT ASSEMBLY REQUIRED.

TABLE OF CONTENTS

HARDWARES LIST	PAGE 2
PARTS LIST	PAGE 3
PARTS' LOCATION	PAGE 4
ASSEMBLY STEPS	PAGE 5 - 6
ASSEMBLY COMPLETED	PAGE 7

ASSEMBLY TOOLS REQUIRED

1. Screwdriver (not provide)

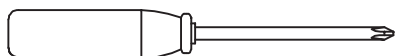

2. Hammer (not provide)

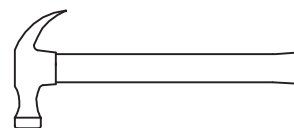

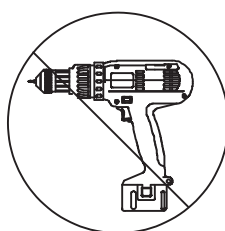

Skip the power drill this time.

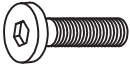

30029-LOVE SEAT ASSEMBLY INSTRUCTION

HARDWARES LIST

ITEM	DESCRIPTION	DRAWING	QTY
A	JCBB SCREW M6 x 15MM	 A technical drawing of a JCBB screw, showing a hexagonal head with a central hole and a threaded shaft.	12 PCS
B	M4 ALLEN KEY (65MM)	 A technical drawing of an M4 Allen key, showing a long shaft with a hexagonal end.	1 PC

30029-LOVE SEAT ASSEMBLY INSTRUCTION

PARTS LIST

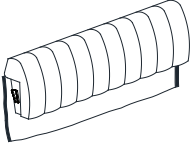
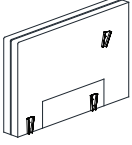
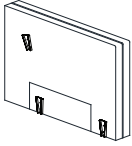
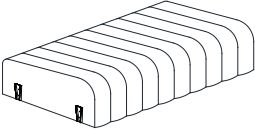
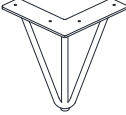
ITEM	DESCRIPTION	DRAWING	QTY
1	BACK PANEL		1 PC
2	SIDE PANEL (L)		1 PC
3	SIDE PANEL (R)		1 PC
4	BOX SEAT		1 PC
5	LEG		4 PCS

30029-LOVE SEAT ASSEMBLY INSTRUCTION

PARTS ' LOCATION

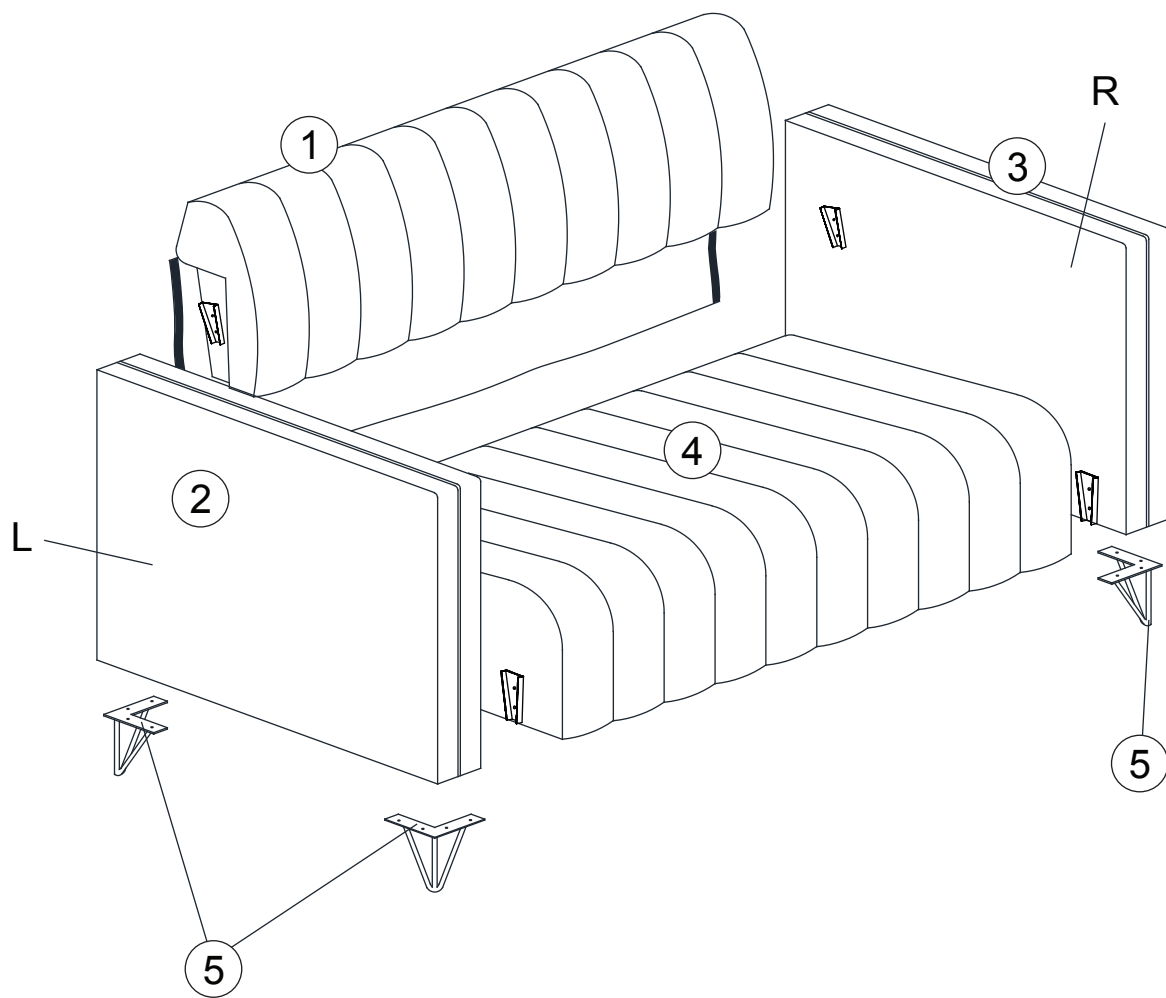

30029-LOVE SEAT ASSEMBLY INSTRUCTION

STEP 1

Get Side Panel from compartment of seat body

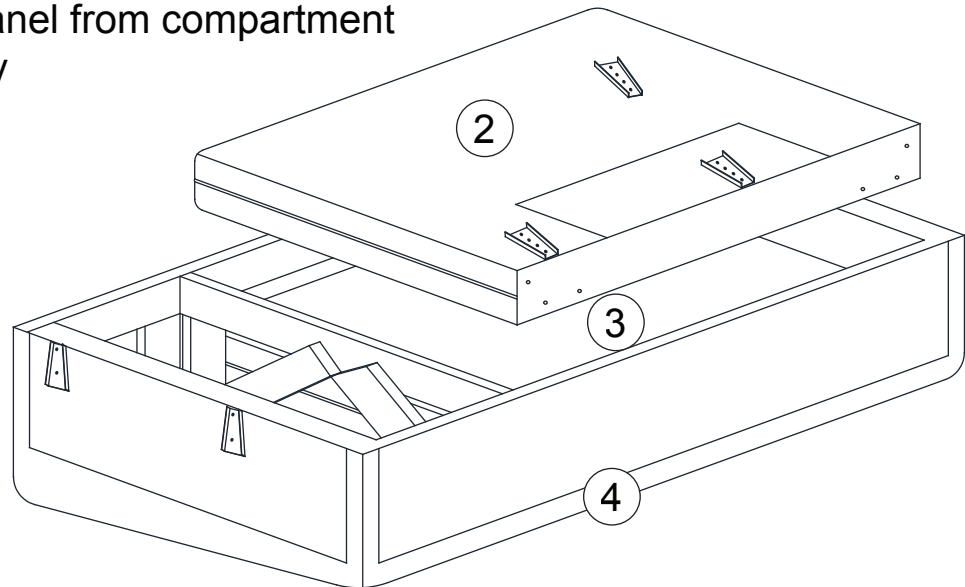

STEP 2

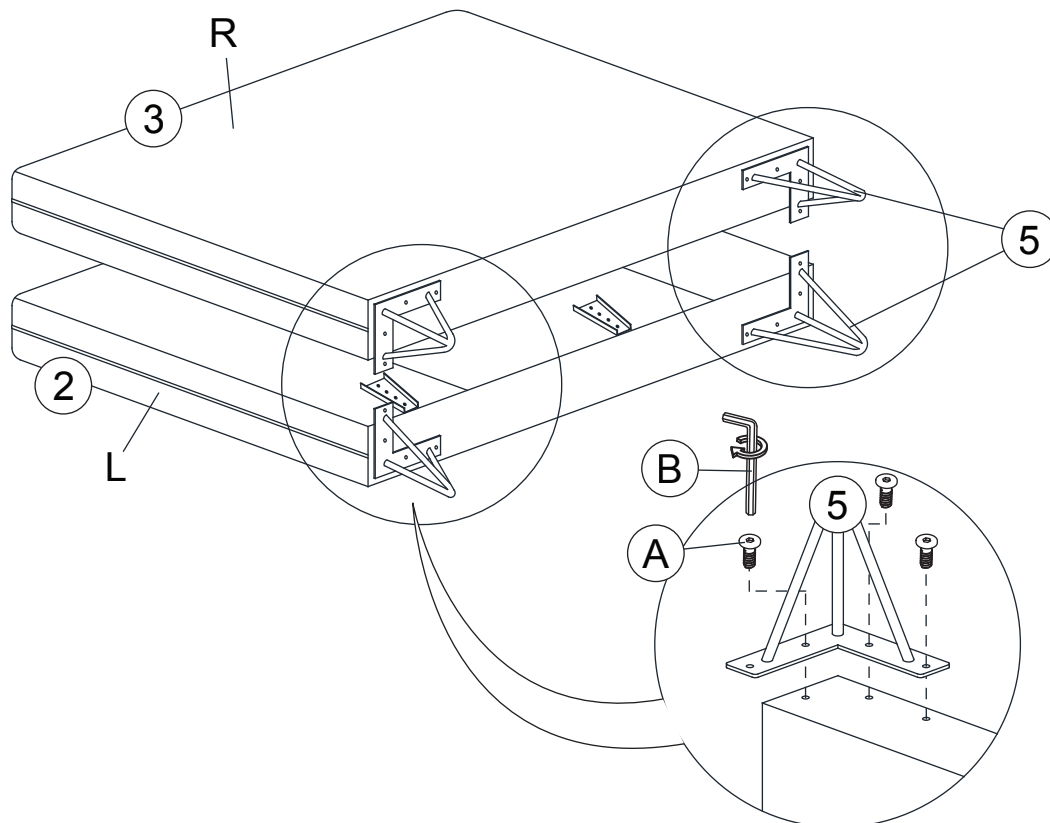

30029-LOVE SEAT ASSEMBLY INSTRUCTION

STEP 3

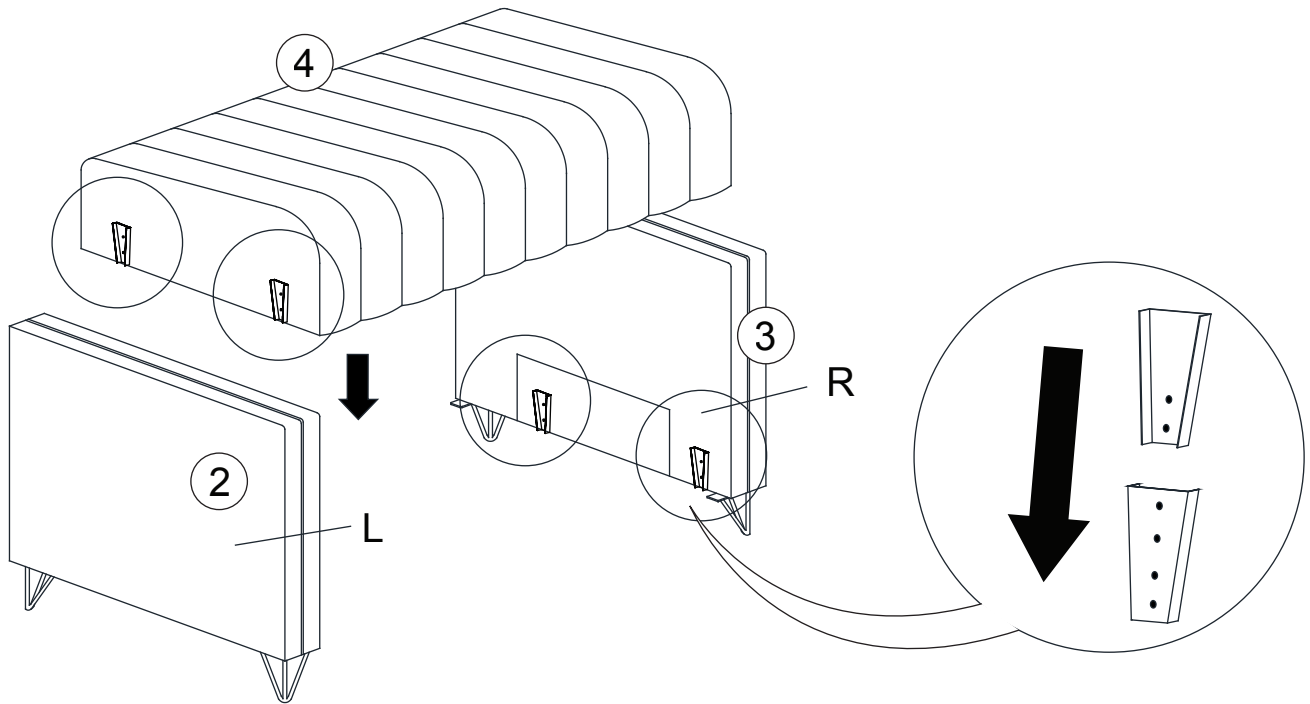

STEP 4

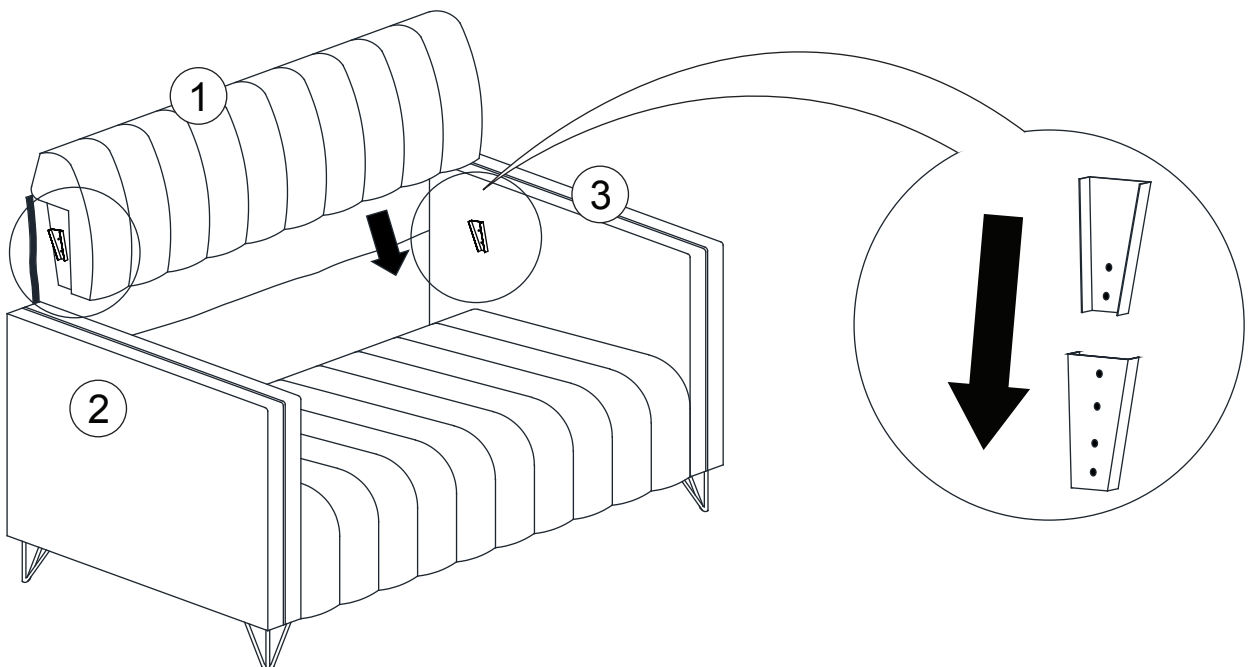

30029-LOVE SEAT ASSEMBLY INSTRUCTION

STEP 5

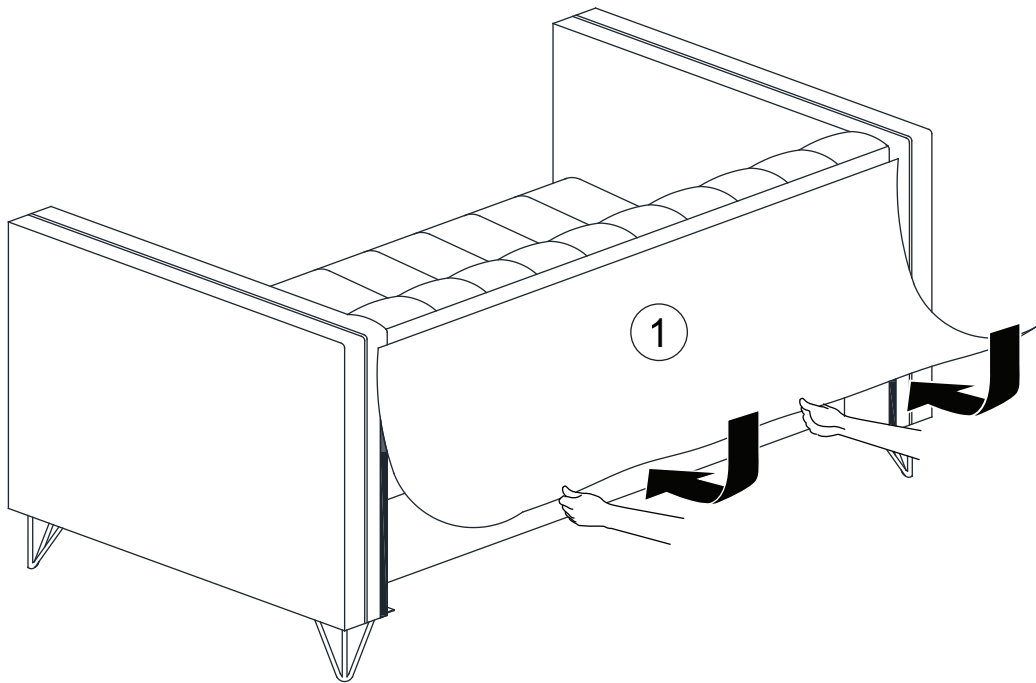

STEP 6

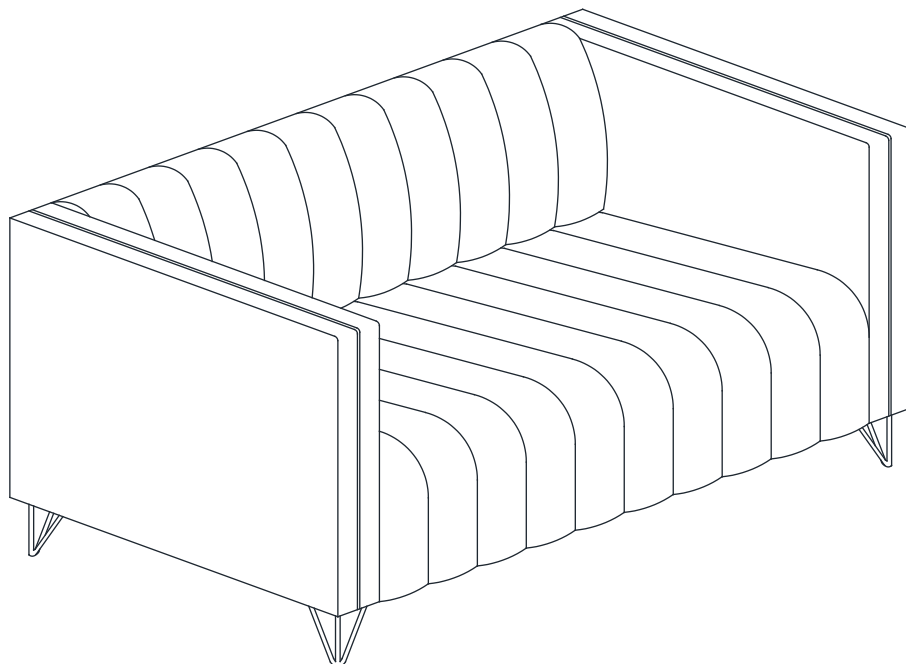

ASSEMBLY COMPLETED