



Anatomy of a Fire Pit

Production:

All merchandise sold by Patina Products is unconditionally guaranteed to be free from defects in material and workmanship. However, logos and images are cut into the sides of our fire pits using a CNC Plasma Cutter and the finished product is 100% hand welded and hand finished. As such, slight variations in patina finish, as well as resolution and detail of customer art work, and/or custom logos are normal, and may vary due to the nature of our manufacturing process. Variations include, but are not limited to patina (rust) finish, logo, image or text placement, quality (thickness, resolution) of line art, cut, and weld penetration and uniformity.

Patina Products Five Year Limited Warranty: Fire Pit drum (fire box) is guaranteed not to rust or burn through for a period of five years or we will replace it at no charge to the customer. You can find complete warranty information at our website by visiting this link: www.patinaproducts.com/firepit_warranty.html

Anatomy of a Fire Pit:

We have dissected our fire pit so that you can see what makes them so special. With an emphasis on quality, safety, and style, the Patina Products Fire Pit is an example of uncompromising design and craftsmanship.

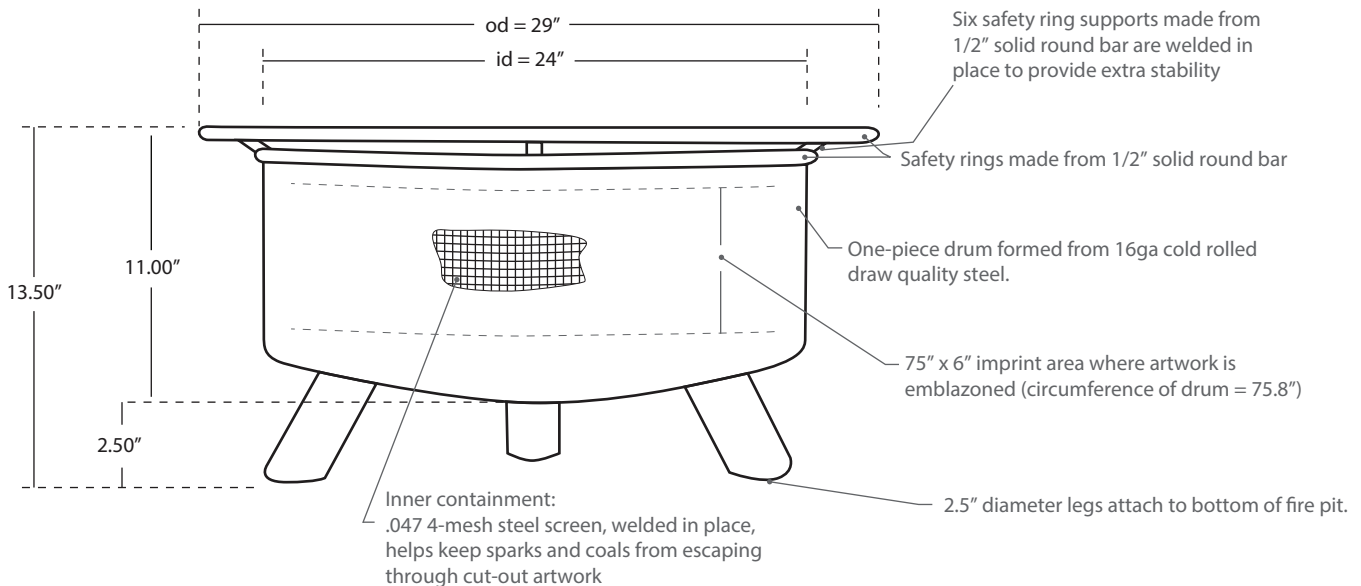

SPARK SCREEN: Black Painted 0.28 8-mesh steel screen
3/8" solid steel round bar frame construction

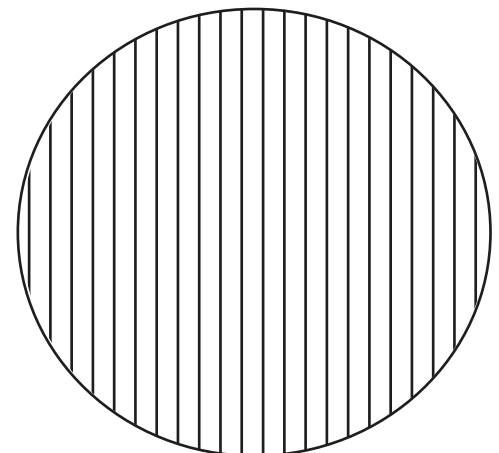
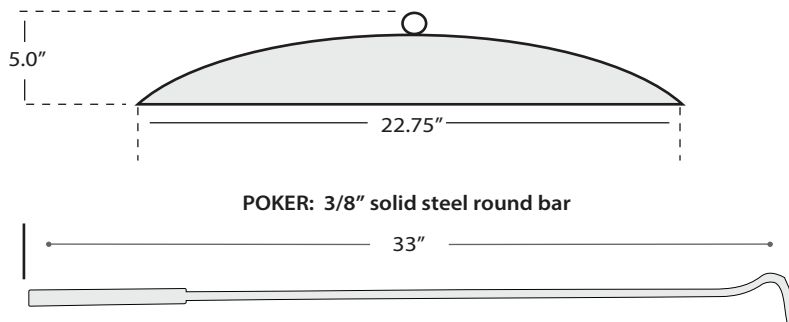

BBQ GRILL: Nickle plated steel 21.5" dia