

INDUSTRIAL WRITING DESK

ASSEMBLY INSTRUCTIONS

Thank you for purchasing our product

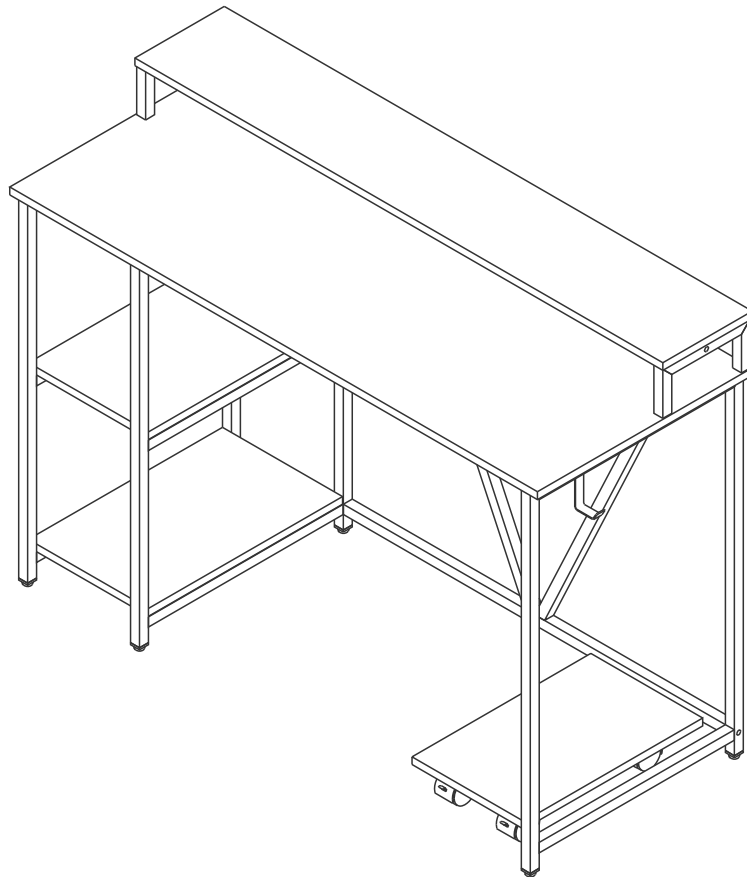

- Do not discard this manual or any of the packaging material until the unit has been completely assembled.



- Please read carefully the assembly instructions before the installation.



- The assembly might require of 2 persons for certain steps. Before you start the installation, make sure there is someone else nearby to help you.



- After the item is assembled, you can use rubbing alcohol to erase or remove the visible part numbers printed or labeled on the pieces.

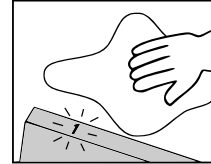

- Please be kind to our planet, when done with the assembly, recycle any of the packaging materials that is accepted by your city or recycling service.



Thank you!



Do a quick inventory of all the parts and hardware listed below



Missing, damaged and defective parts can be replaced at no cost to you. Please refer to the last pages on this manual.



The replacement parts service is limited to the 48 contiguous United States. If you reside in AK, HI, PR, U.S. territories or other countries, please contact the supplier from where the unit was purchased.







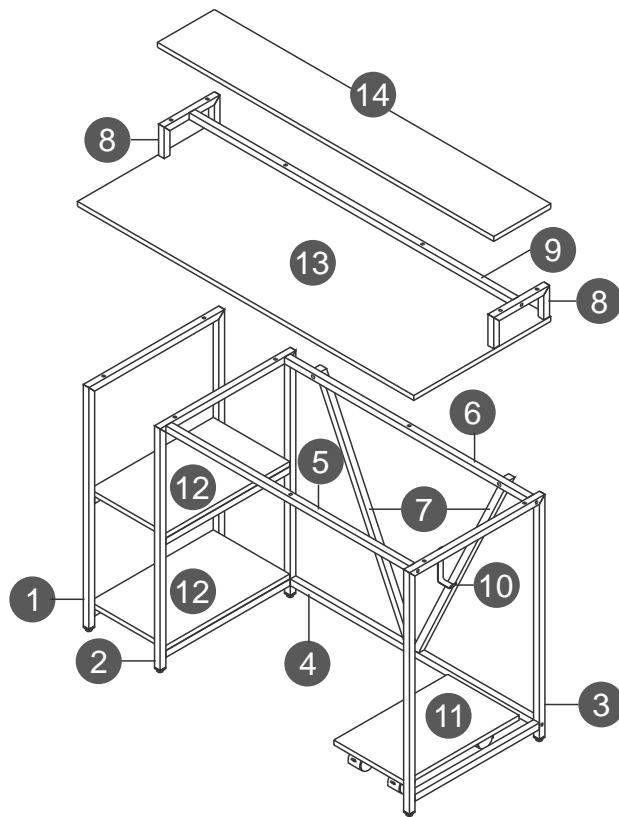

MAIN PARTS LIST

| | | | |
|---|---|---|--|
| <p>1 Left frame x1</p> | <p>2 Middle frame x1</p> <p>Frame #2 has more holes than frame #1</p> | <p>3 Right frame x1</p> | <p>4 Bottom tube x1</p> <p>33.5"</p> <p>2 holes on same side</p> |
| <p>5 Top-front tube x1</p> <p>33.5"</p> <p>1 hole</p> | <p>6 Top-back tube x1</p> <p>33.5"</p> <p>2 holes on same side, 1 hole on opposite side</p> | <p>7 Back support tube "V" x2</p> <p>30"</p> <p>1 hole by the end</p> | <p>8 Top shelf support tube x2</p> |
| <p>9 Top shelf horizontal tube x1</p> <p>44.6"</p> | <p>10 Headphones hook x1</p> | <p>11 CPU Panel x1</p> | <p>12 Left shelf panel x2</p> |
| <p>13 Main panel x1</p> | <p>14 Top shelf panel x1</p> | | |

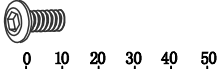
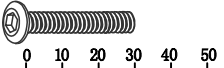

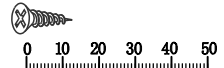
MAIN PARTS LAYOUT (For reference)



HARDWARE LIST

| PART | QTY | SIZE | ITEM |
|------|-----|--------------------|---|
| A | 1 | M6x12 |  |
| B | 28 | M6x30 |  |
| C | 10 | M6x45 |  |
| D | 16 | M3.5x12 |  |
| E | 2 | M6, 10x11mm |  |
| F | 2 | Locking caster |  |
| G | 2 | Non-locking caster |  |

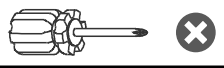
INCLUDED TOOLS

| | | |
|---|----------------------|---|
| 1 | Phillips Screwdriver |  |
| 1 | M4 Allen Wrench |  |
| 1 | M10 Spanner |  |

BEFORE YOU START THE ASSEMBLY, PLEASE READ THE FOLLOWING TIPS AND WARNINGS.

- Do not discard this manual or any of the packaging material until the unit has been completely assembled.



- If during assembly you find an issue or need clarification, please contact our Customer Service for assistance. Please refer to the last pages on this manual.



- On each step read the instructions thoroughly and analyze the illustrations before proceeding to do the assembly.
- Follow the instructions step by step and do not skip any unless our Customer Service advises it is OK to do so.



- Make sure you understand which hardware will be used on each step. Using the wrong size of screw, bolt or pin might strip the threads or cause damage to the part in which it is being used.

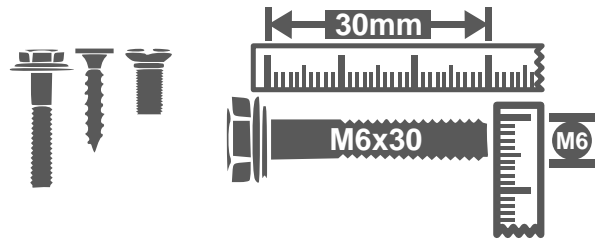

- To avoid misalignments, always leave the screws loose and tighten them until all pieces are positioned correctly.

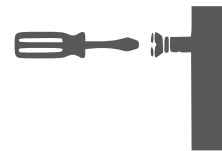

- Do not overtighten or force the screws as they might break, strip, damage the threads of the holes or get stuck inside the part.

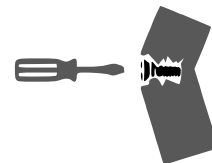

- If the hole seems too small for the screw, make sure you are using the correct size of screw and/or that you are installing it in the correct hole.



- Sometimes on the panels the laminate or material might be covering the hole partially or entirely. If there is no visible hole or it seems too small, pass and press the tip of your finger over the area where the hole should be located to feel its indentation, and once found, carefully pierce the laminate to uncover the hole underneath.



ASSEMBLY STEPS

STEP 1

Hardware

| | | |
|----------|---|-----|
| B |  | 4 |
| | M6x30 | Pcs |

Tools (included)

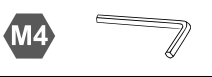

Assemble the first left shelf **12** to the middle bars on the frames **1** and **2** with screws **B** from underneath.

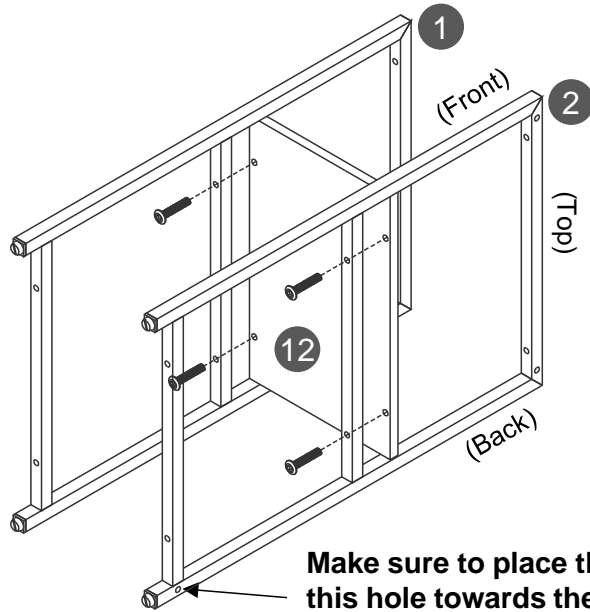

Make sure to place the frame with this hole towards the back of the unit, it is needed for step 3.

STEP 2

Hardware

| | | |
|----------|---|-----|
| B |  | 4 |
| | M6x30 | Pcs |

Tools (included)



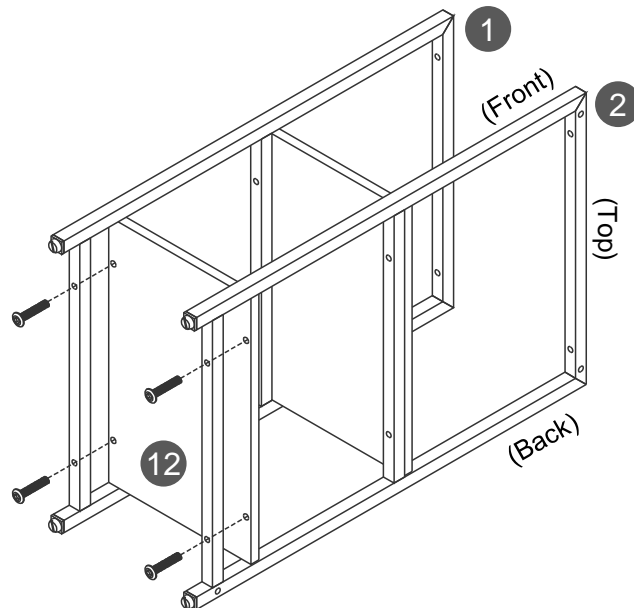

Assemble the second left shelf **12** to the bottom bars on the frames **1** and **2** with screws **B** from underneath.



STEP 3

This step requires of 2 persons

Hardware

| | | |
|----------|---|-------|
| A |  M6x12 | 1 Pc |
| C |  M6x45 | 6 Pcs |

Tools (included)



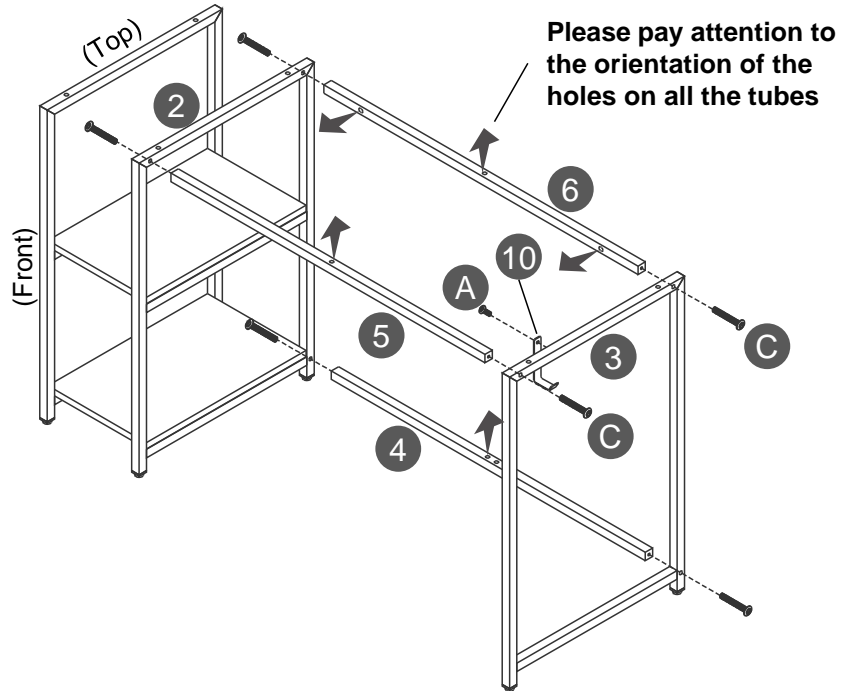

Bring the cabinet built in step 2 to the upright position, then with the help of another person:

- Assemble the tubes **4**, **5** and **6** to the middle frame **2** in their respective positions with screws **C**.
- Assemble the right frame **3** to the tubes **4**, **5** and **6** with screws **C**.
- Attach the hook **10** to the frame **3** with screw **A** from the inside.



STEP 4

Hardware

| | | |
|----------|---|-------|
| B |  M6x30 | 2 Pcs |
| C |  M6x45 | 2 Pcs |

| | | |
|----------|--|-------|
| E |  M6 | 2 Pcs |
|----------|--|-------|

Tools (included)

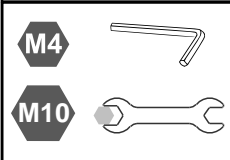

- Assemble the support tubes **7** to the top tube **6** on the back of the unit with screws **C** from outside and nut caps **E** from inside.
- Assemble the support tubes **7** to the bottom tube **4** with screws **B** from underneath.

Note: If you don't see holes for the screws on the tubes **4** and **6**, review step **3** for the correct assembly of those tubes.

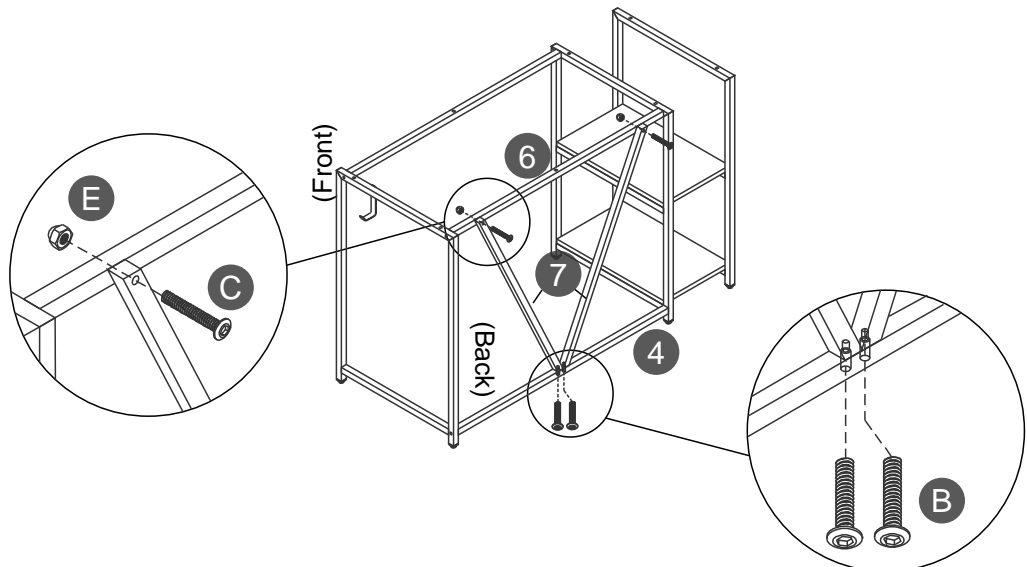

STEP 5

Hardware

| | | |
|----------|---|-----|
| C |  | 2 |
| | M6x45 | Pcs |

Tools (included)

| | |
|-----------|---|
| M4 |  |
|-----------|---|

Assemble the top shelf support tubes **8** to the shelf horizontal tube **9** with screws **C**.

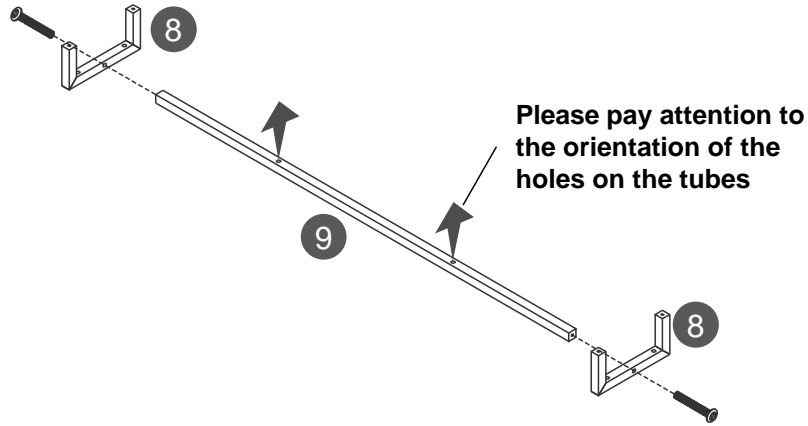

STEP 6

Hardware

| | | |
|----------|---|-----|
| B |  | 6 |
| | M6x30 | Pcs |

Tools (included)

| | |
|-----------|---|
| M4 |  |
|-----------|---|

Assemble the tubes **8** and **9** to the top shelf panel **14** with screws **B**.

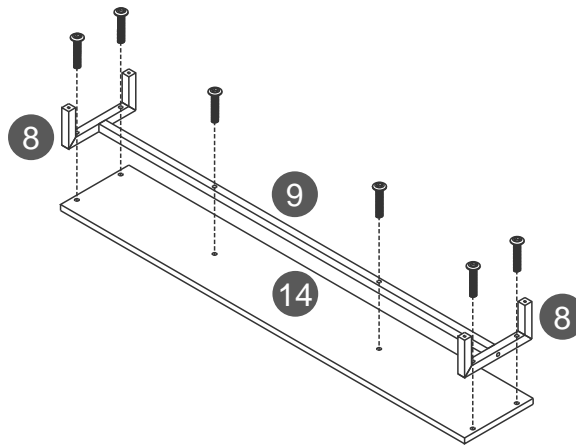

STEP 7

This step requires of 2 persons 

Hardware

| | | |
|----------|---|-----|
| B |  | 4 |
| | M6x30 | Pcs |

Tools (included)

| | |
|-----------|---|
| M4 |  |
|-----------|---|

With the help of another person, assemble the main panel **13** to the tubes **8** with screws **B** making sure the bottom surface faces **UP** like shown in the illustration.

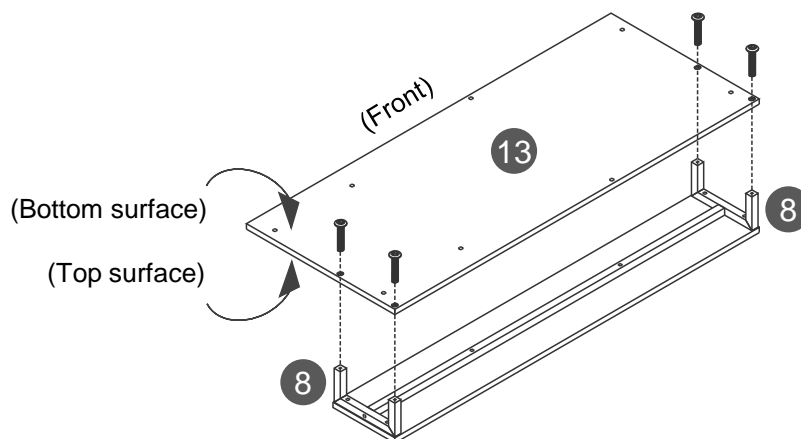

STEP 8

This step requires of 2 persons 

Hardware

B  8 Pcs
M6x30

Tools (included)

M4 

With the help of another person, assemble the main panel **13** to the frames **1**, **2** and **3** and to the tubes **5** and **6** with screws **B** from underneath.

Note: If you don't see holes for the screws on the tubes **5** and **6**, review step **3** for the correct assembly of those tubes.

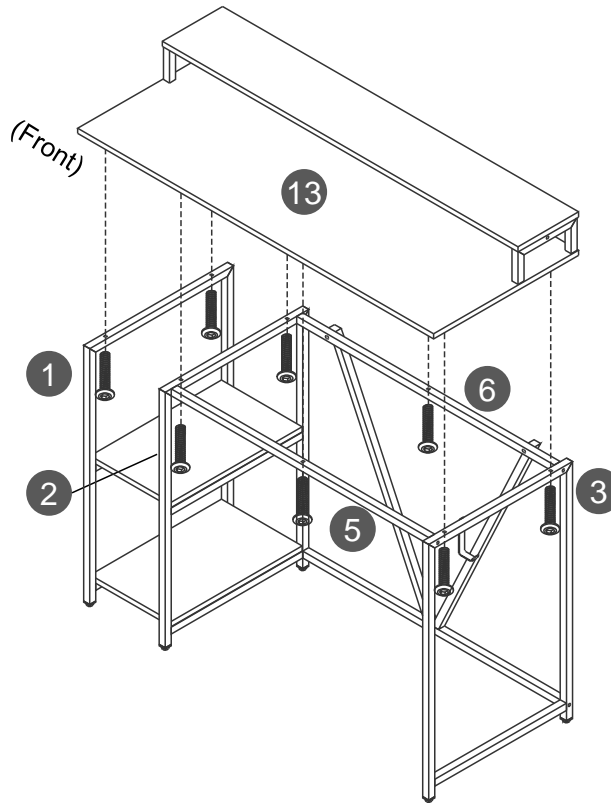

STEP 9

Hardware

D  16 Pcs
M3.5x12

F  2 Pcs
Locking

G  2 Pcs
Non-locking

Tools (included)

Assemble the casters **F** and **G** to the CPU panel **11** with screws **D**, making sure the Locking casters **F** are attached on the same side that will be considered the **FRONT** of the cart.

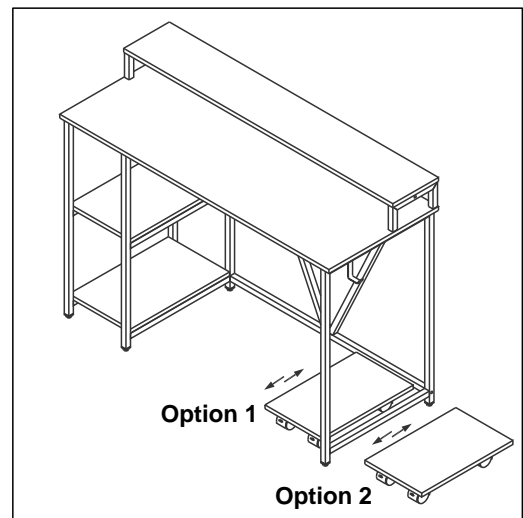
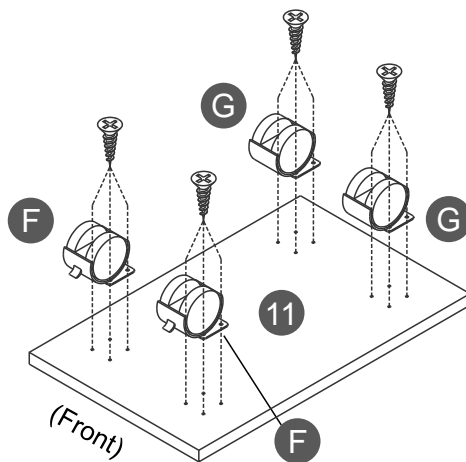

WEIGHT LIMITS**WARNINGS**

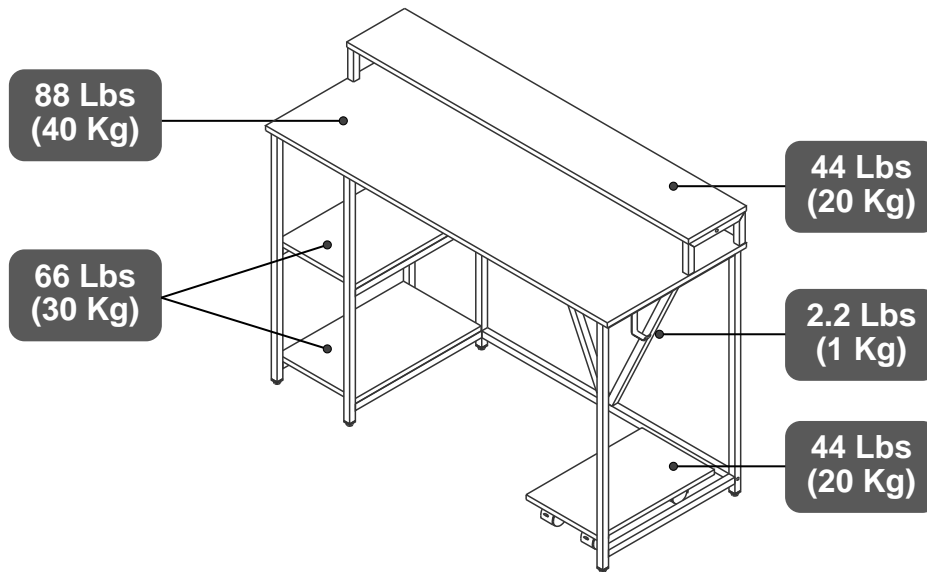
- Do not exceed the indicated weight limits.
- Do not expose the surfaces to direct sunlight or to extreme environmental conditions.
- Do not use solvents or abrasive materials to clean the unit.
- Do not sit on the unit or lean against it.
- Do not allow small children to play under or over the unit.
- Do not allow small children to play with the CPU cart as a moving vehicle.
- Do not pull, push or drag the unit to move it for more than 1 feet. The unit must be lifted by at least 2 persons when moving in the same or adjacent rooms.
- Before moving the unit, make sure to secure or remove any object that is heavy or might fall off.
- When lifting the unit, use both hands and bend your knees, not your backs.

CARE AND MAINTENANCE

- Clean the surfaces preferable with a clean cloth damped in a solution of mild soap and water, then dry with a clean towel.
- If you decide to use a cleaning agent, test first on an area hidden from view such as underneath the tabletop.
- Every 4 months, inspect the unit completely and make sure that all screws are tighten.
- When transporting the unit to places far away, protect and secure the unit to avoid damage in transit.
- Shall any part of the unit become defective during the warranty period, replacement parts might be available to you at no charge. Please refer to the last pages on this manual.
- The warranty does not extend to regular wear and tear, nor the manufacturer assumes liability for damages or consequences due to accidents, incorrect assembly, negligence, improper use, modifications, or not heeding the above warnings.

TECHNI MOBILI WARRANTY**DESKS/LAPTOP CARTS/FILE CABINETS: LIMITED 5-YEAR WARRANTY**

We warrant to the Original Purchaser who acquired a new product from Techni Mobili or its authorized resellers that this product will be free from defects in its workmanship and materials, under normal use and service conditions, as described herein. "Defects" as used in this warranty, is defined as any imperfections that impair the use of the furniture or product. We will replace any defective part, at its discretion, and without charge to the original purchaser other than the freight from the end consumer to Techni Mobili.

Replacement parts can only be supplied if parts are available. Items out of production may be unavailable. This warranty will be effective for the applicable time period beginning the date of purchase on your original sales receipt. Techni Mobili's obligation under this warranty is limited to repairing or replacing products or parts as provided herein. This product has been designed for and is intended for office and home-office use only. This warranty is Original Purchaser's sole remedy for product defects, and this warranty does not extend to any product, or damage to any product, caused by or attributed to abuse or misuse, products used for commercial or rental purposes, use modifications of, or attachments to the product, and products or parts not used, maintained, or extended hereunder is in lieu of any and all other warranties, express or implied, including without limitations any implied warranty or merchantability or of fitness for a particular purpose. Please note, all desks made with PVC Laminate surface should not be exposed to direct sunlight, as it may damage the material. Damage of this nature is not covered under this warranty.

We will not be responsible for indirect, special, incidental or consequential damages. This warranty is limited to merchandise purchased in the Continental United States, excludes AK, HI and PR. Some States do not allow the exclusion or limitation of incidental or consequential damages, so the above limitations or exclusions may not apply to you. This warranty gives you specific legal rights. You may also have other rights that may vary from state to state.

We will advise you of the procedure to follow in making warranty claims. The following are the procedures for warranty claims:

- a. Call us to explain the defect and give your name, address and phone number. Please have ready the model number of our product, date and place of purchase. You can also write to us by e-mail and include the same information.
- b. If we determine that replacement will remedy the situation, and in order to determine the extent or the cause of the defect, purchaser will need to send the part in question at purchaser's expense. Once we receive the part, we will examine it and determine whether the claim is valid (or not), and then proceed to send the replacement. We will ship the replacement at our expense.