

Assembling Instruction

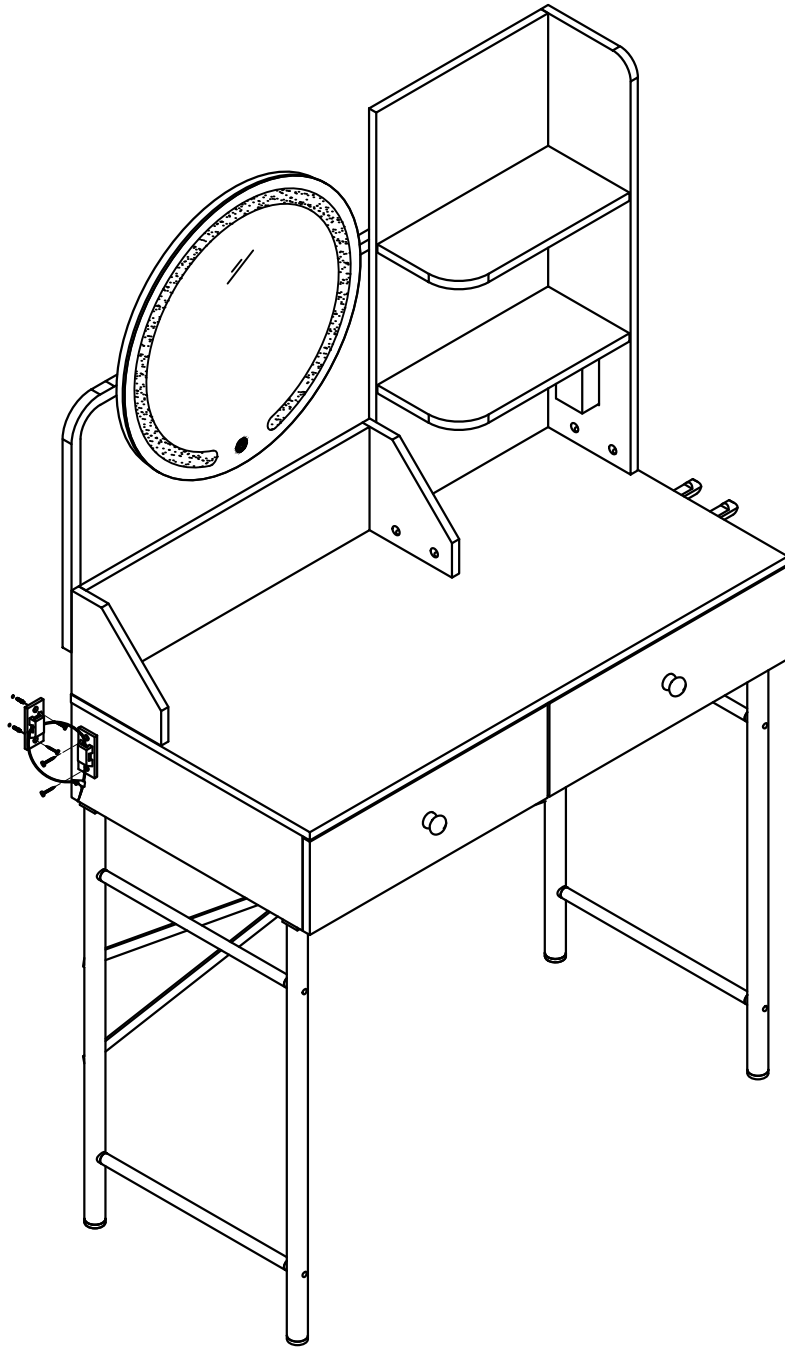

PRODUCT DIMENSIONS
800MM*400*1360MM

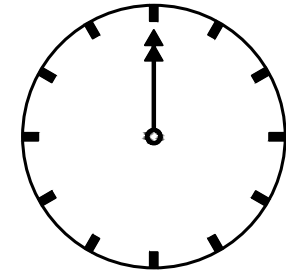

60 MIN

APPROXIMATE ASSEMBLY TIME

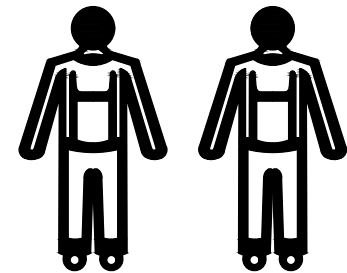

1~2

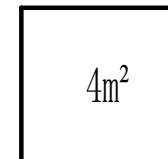

4m²

FLOOR AREA 2M*2M

REQUIRED ASSEMBLY SPACE

General Guidelines – Important Notice

● General Guidelines – Important Notice

Before starting assembly, be sure to read these instructions in full.

Please keep this manual and hand it over when transferring the product. This summary may not cover all variants or every detail of the steps to be considered. If you have any questions during installation, please contact us and we will provide assistance within 24 hours.

● Precautions

This product is for indoor use only. Assembly and use must be carried out in accordance with the instructions.

To avoid damaging your product, ensure that your electric drill is set to a low-torque mode.

Do not expose the product to humid environments for extended periods to prevent mold growth. During assembly, first align all screws with their corresponding pre-drilled holes, then tighten them one by one.

Check the screws regularly; they may loosen after long-term use. Retighten them if necessary to ensure stability and safety.

The seller shall not be liable for any damage or injury caused by improper assembly or use.

● Warnings

Children must not assemble this product. During assembly, keep children and pets away from the work area. Keep all small parts out of children's reach to prevent fatal risks from swallowing or inhalation. Children must not stand on, climb on, or play on the product to avoid serious bodily injury from product tipping. Keep plastic packaging bags out of children's reach to prevent potential suffocation hazards. Avoid contact between sharp objects, corrosive chemicals and the product to prevent product damage or bodily injury.

● Tip-over Warning!

Tipping furniture can cause serious or fatal crushing injuries. To prevent tipping, be sure to use the included wall anchoring device (if the product is not equipped with one). Purchase a wall anchoring device that matches your wall size. If in doubt, seek professional advice. Read and follow each step in the instructions carefully.

Do not allow children to climb on the furniture or hang items on it

Do not open multiple drawers at once

Do not place heavy objects in the top drawer

Do not place heavy objects on top of the furniture

Note that only the anti-tip nails are provided.

You will also need to prepare wall plugs and screws suitable for your wall type.

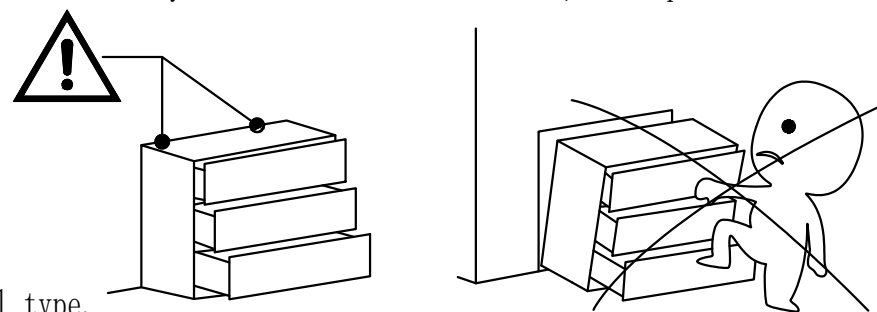

● Maintenance and Care

Clean the device only with a damp cloth. Inspect it regularly and use mild detergent; do not use bleach or abrasive cleaners to avoid damaging the device.

This device should not be disposed of with household waste and must be taken to a local government waste disposal center.

Tools required

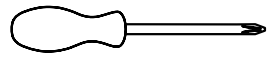

Phillips screwdriver

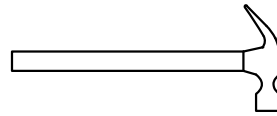

Hammer

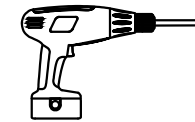

Electric drill

Ruler - Use this ruler to help correctly identify the screws

A horizontal ruler with markings from 0 to 170 millimeters. Major markings are every 5 mm, and minor markings are every 1 mm. The numbers 0, 5, 10, 15, 20, 25, 30, 35, 40, 45, 50, 55, 60, 65, 70, 75, 80, 85, 90, 95, 100, 105, 110, 115, 120, 125, 130, 135, 140, 145, 150, 155, 160, 165, and 170 are printed along the top edge.

0 5 10 15 20 25 30 35 40 45 50 55 60 65 70 75 80 85 90 95 100 105 110 115 120 125 130 135 140 145 150 155 160 165 170



The screws length is measured from the head to the point (30mm screw shown).

Note: be sure to use the proper screws to avoid damaging the parts.

Using Camlocks

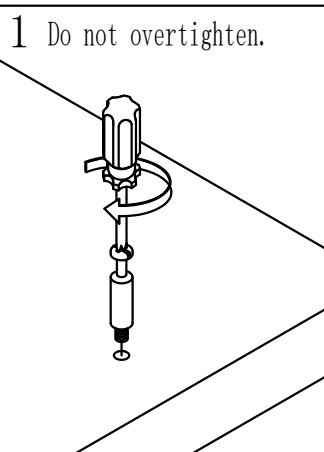

Step 1: Following the assembly instructions, use a screwdriver to connect the cam dowel.

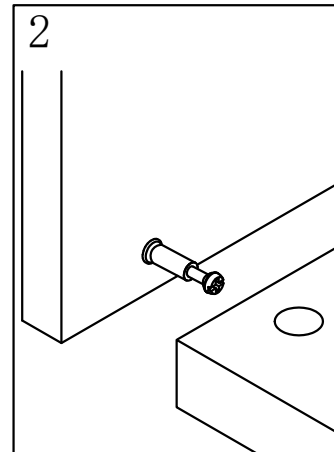

Step 2: Insert the cam dowel into the entry hole

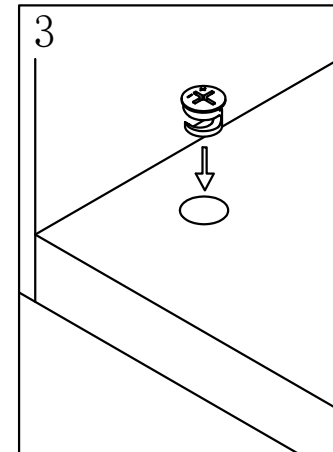

Step 3: Insert the cam lock as shown. Make sure the arrow on top of the cam lock points toward the opening where the dowel enters.

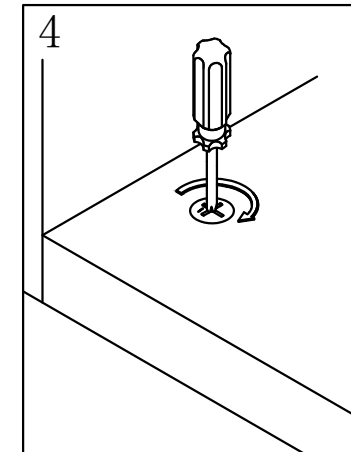

Step 4: Turn the cam lock clockwise with a screwdriver. You will hear a click when it is fully locked. The joint is now secured.

Main parts list (1)

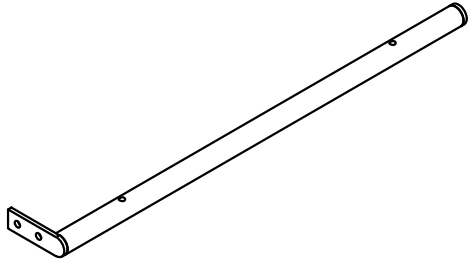

① X1

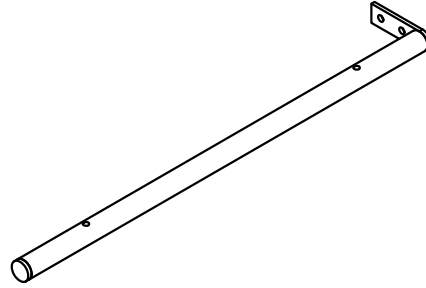

② X1

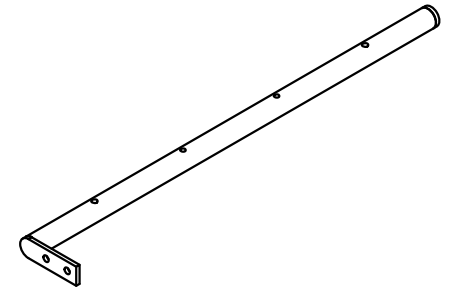

③ X1

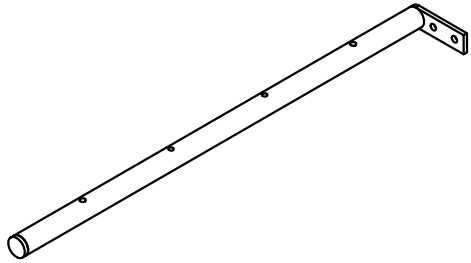

④ X1

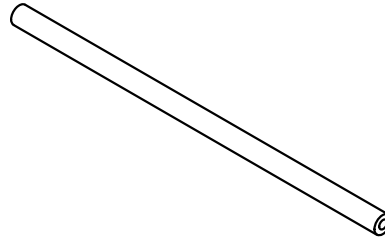

⑤ X4

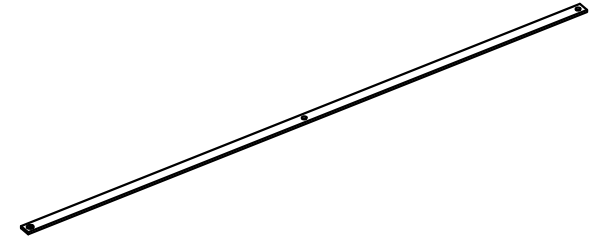

⑥ X2

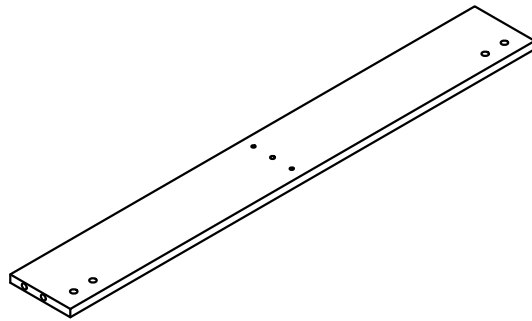

⑦ X1

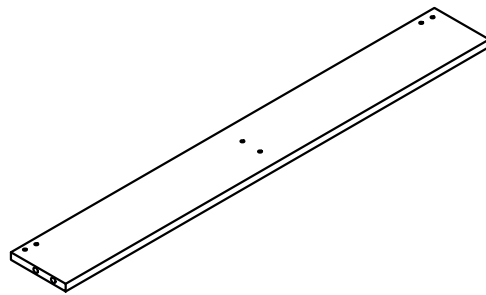

⑧ X1

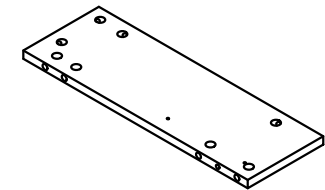

⑨ X1

Main parts list (2)

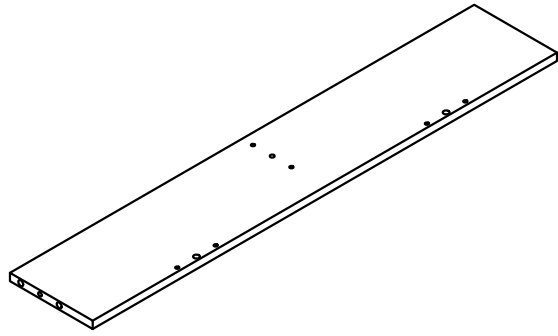

⑩ ×1

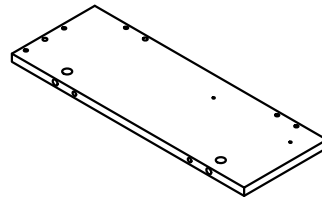

⑪ ×1

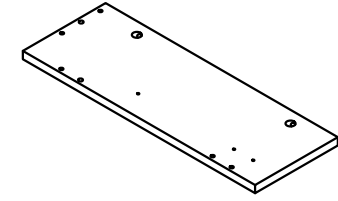

⑫ ×1

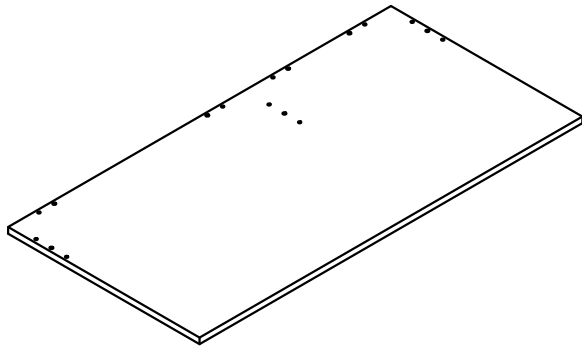

⑬ ×1

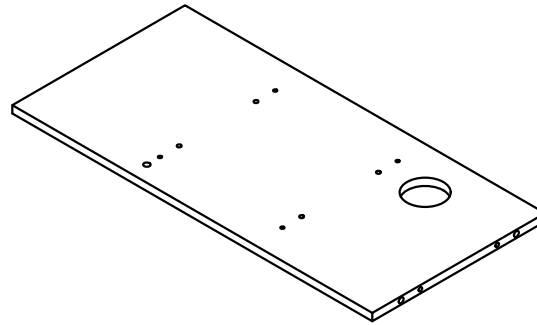

⑭ ×1

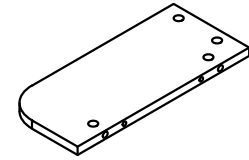

⑮ ×2

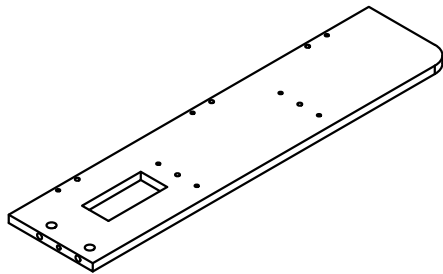

⑯ ×1



⑰ ×1

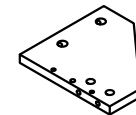

⑱ ×1

Main parts list (3)

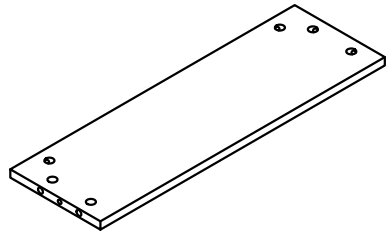

⑲ × 1

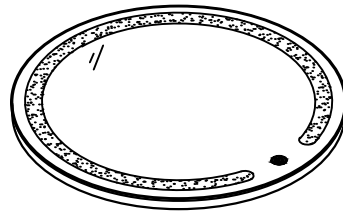

⑳ × 1

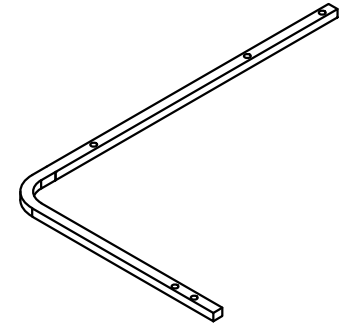

㉑ × 1

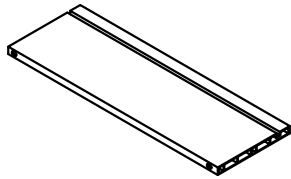

㉒ × 2

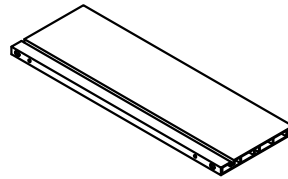

㉓ × 2

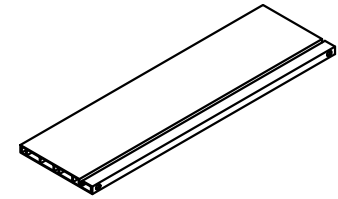

㉔ × 2

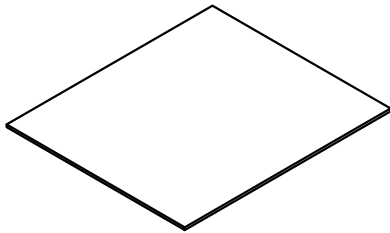

㉕ × 2

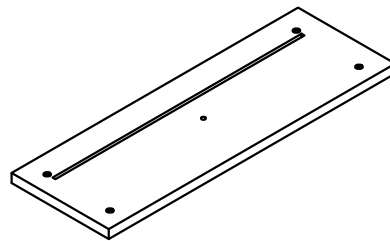



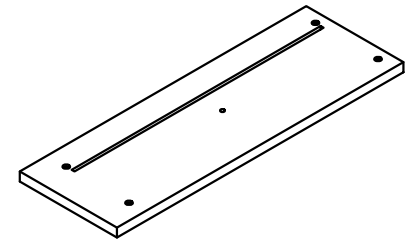



㉖ × 1

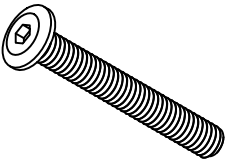
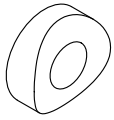

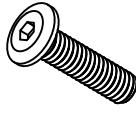
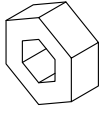
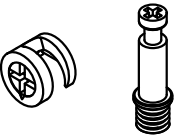
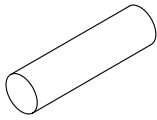

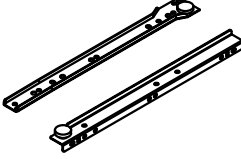
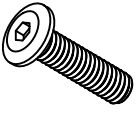
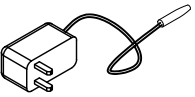

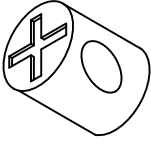
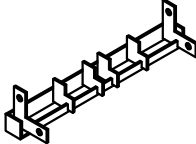
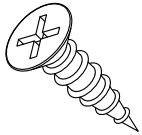
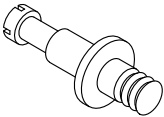
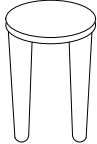
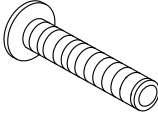
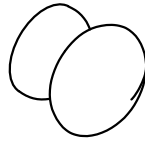
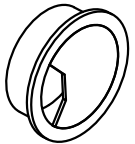
㉗ × 1

Accessories List(1)

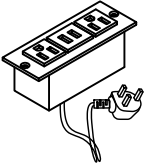
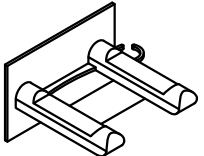
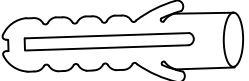
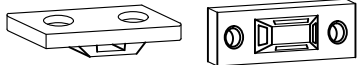
<p>(A) X8</p>  <p>M6*50</p>	<p>(B) X8</p>  <p>φ16</p>	<p>(C) X1</p>  <p>S=4</p>	<p>(D) X13</p>  <p>M6*16</p>	<p>(E) X1</p>  <p>10*5-M6</p>
<p>(F) X58+5</p>  <p>20mm</p>	<p>(G) X32</p>  <p>φ6*30</p>	<p>(H) X36+3</p>  <p>φ 3.5*12</p>	<p>(I) X2</p>  <p>300MM</p>	<p>(J) X3</p>  <p>M6*25</p>
<p>(K) X1</p>  <p>152*30*7</p>	<p>(L) X2</p>  <p>φ 5*45</p>	<p>(M) X2</p>  <p>φ 9*9</p>	<p>(N) X4</p>  <p>100MM</p>	<p>(O) X36+3</p>  <p>φ 3*12</p>
<p>(P) X8</p>  <p>φ 7.5*24.5</p>	<p>(Q) X8</p>  <p>φ 8*11</p>	<p>(R) X2</p>  <p>M4*20</p>	<p>(S) X2</p>  <p>φ 24</p>	<p>(T) X1</p>  <p>φ 60</p>

Accessories List(2)

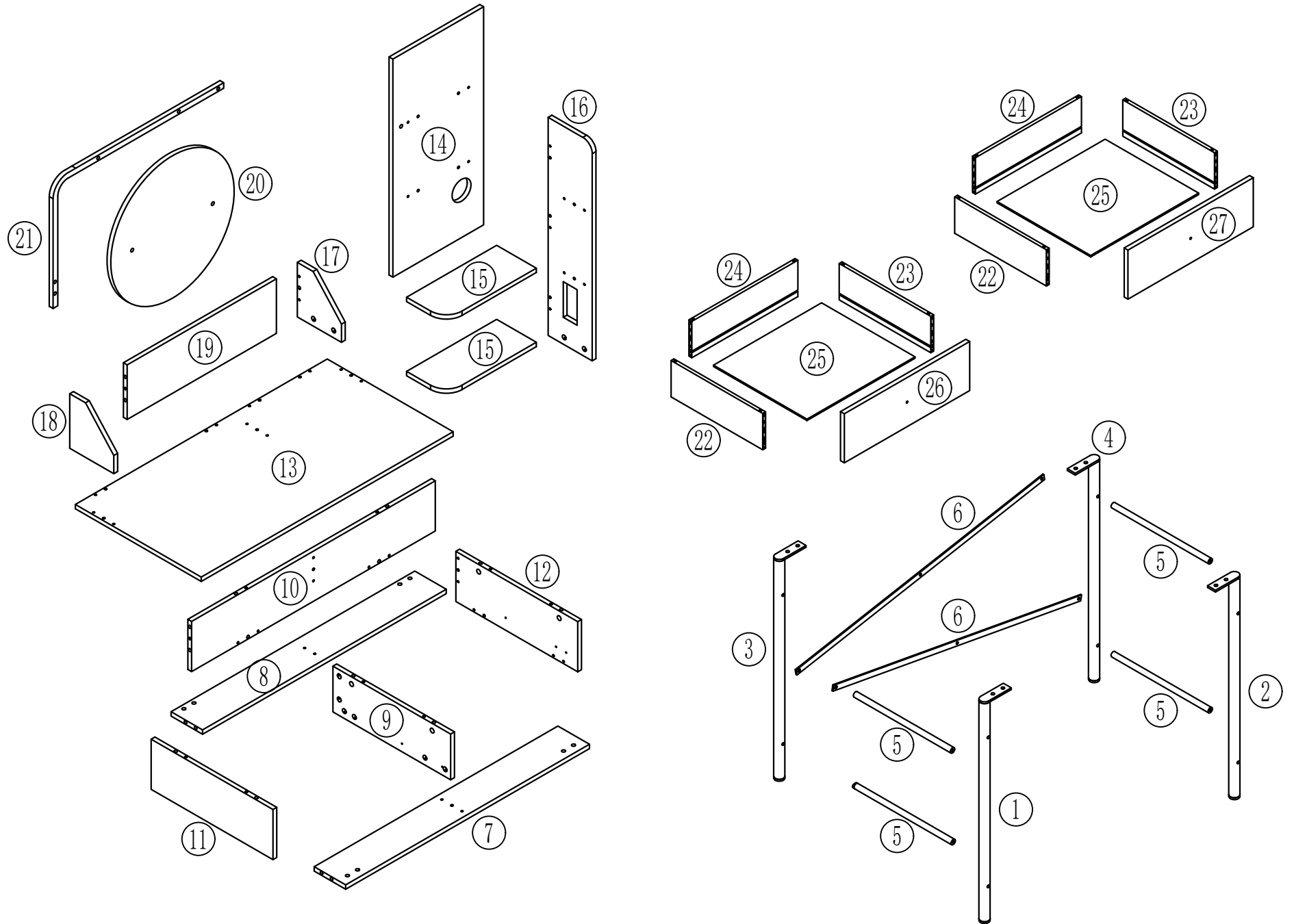

U	X1	V	X1	W	X4	X	X2	Y	X4
									
123*46*44		95*50*75		$\phi 8*34$		19*42*8		ST4*35	
Z	X4	A1	X2						
									
$\phi 3.5*12$		245*7*1							

Assembling Instruction



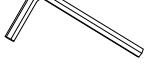

Assembling Instruction

Step 1

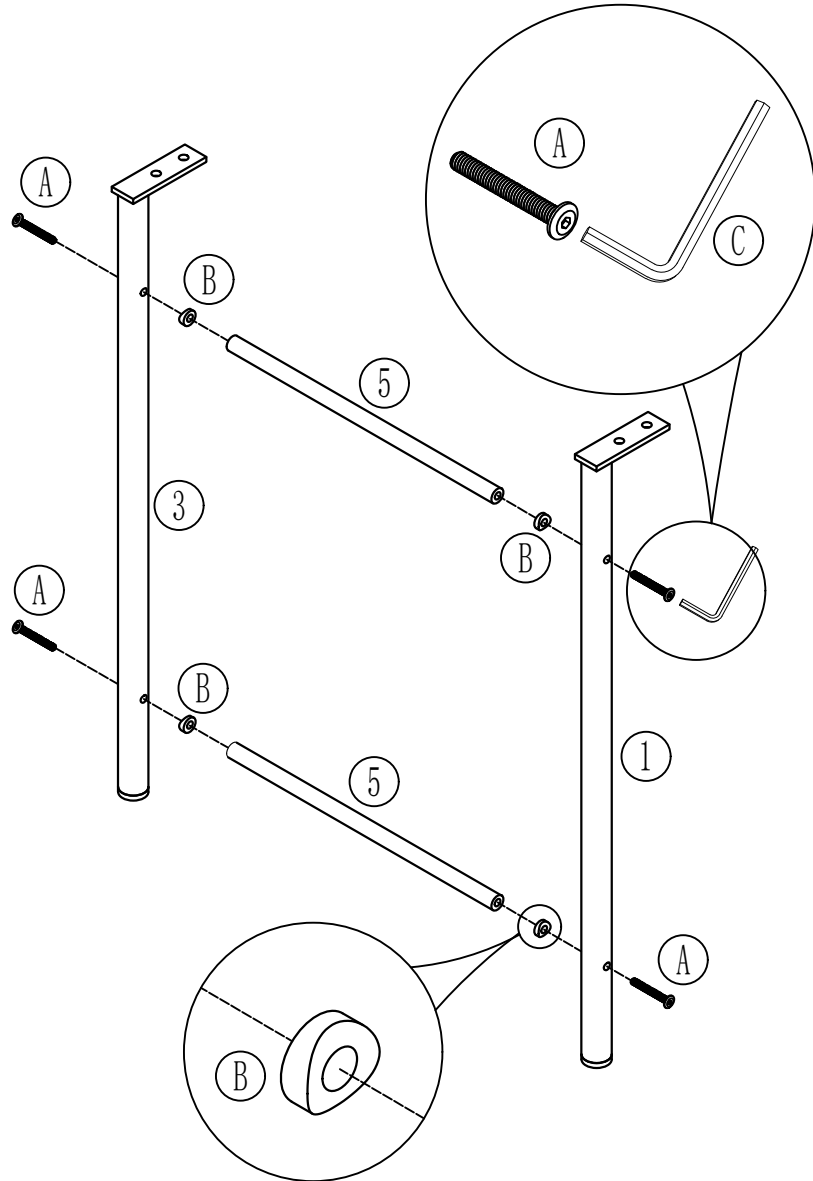
(A)	X4	(B)	X4	(C)	X1
					
M6*50		φ16		S=4	



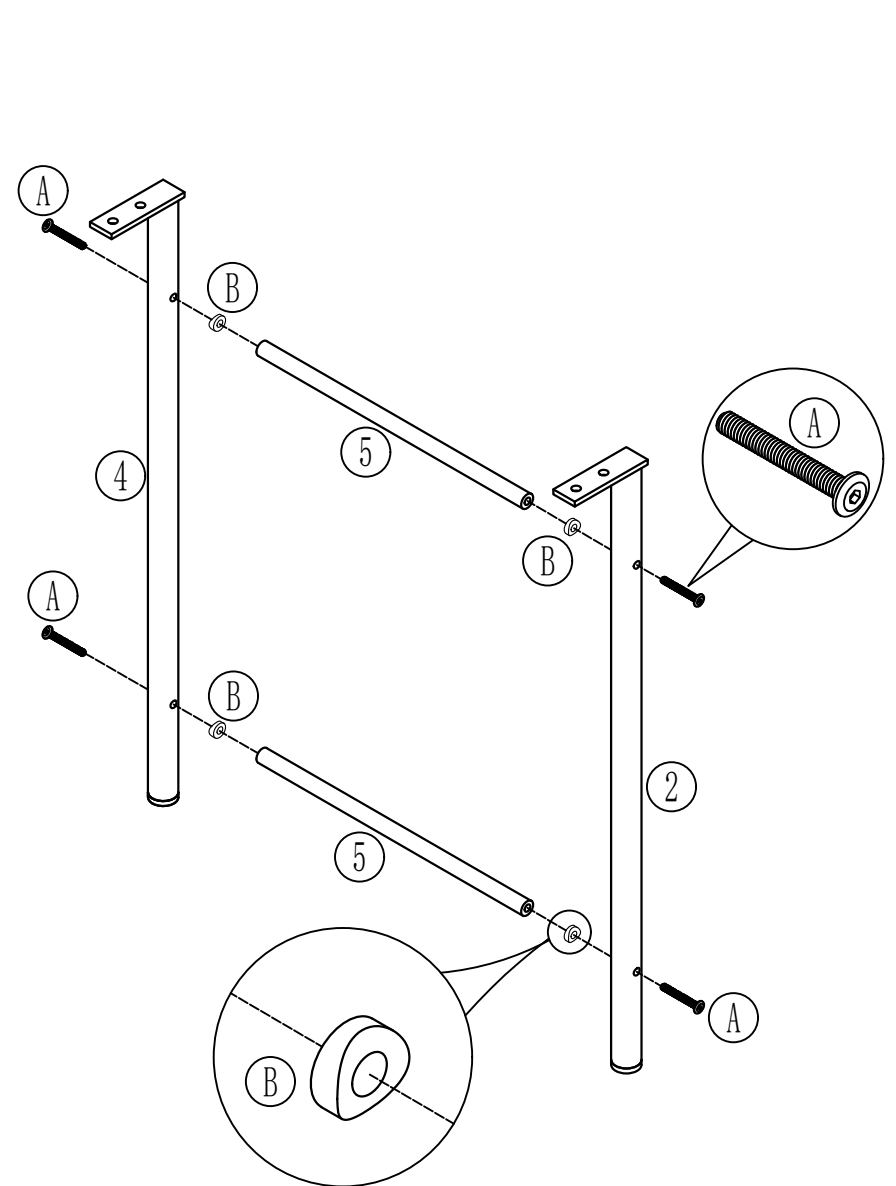

Step 2

(A)	X4	(B)	X4
			
M6*50		φ16	



Assembling Instruction

Step 3

(D)	X5	(E)	X1
			
M6*16		Ø10*5-M6	

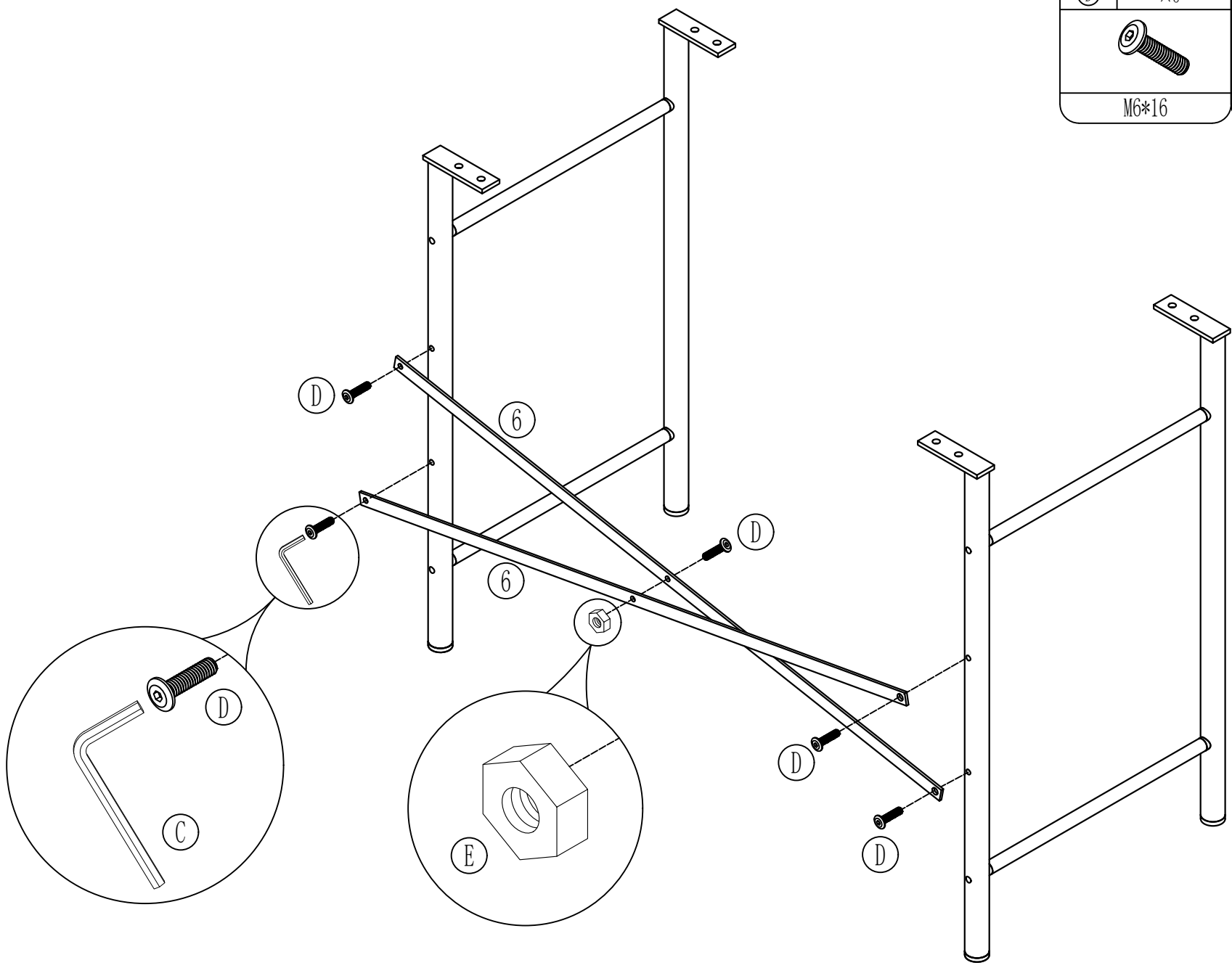

Assembling Instruction

Step 4

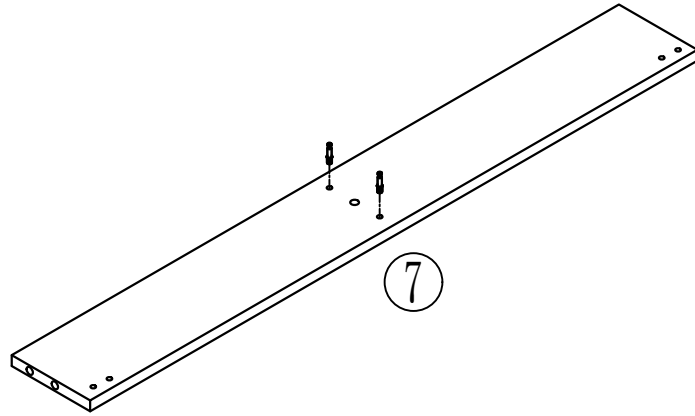
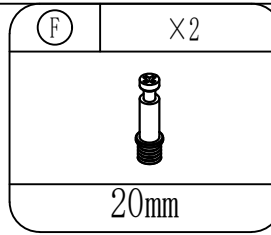

Step 5

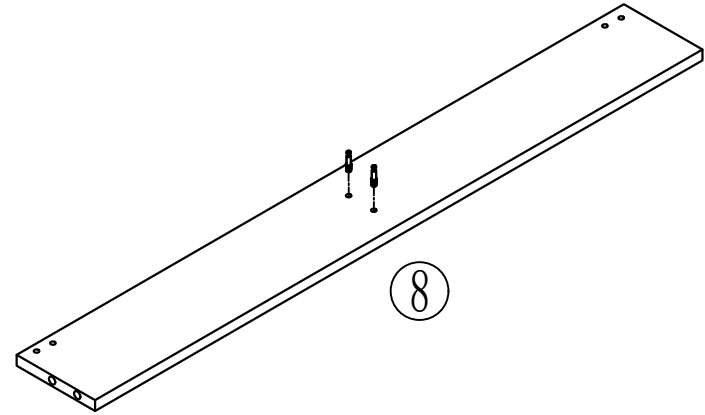
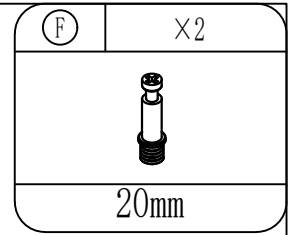

Step 6

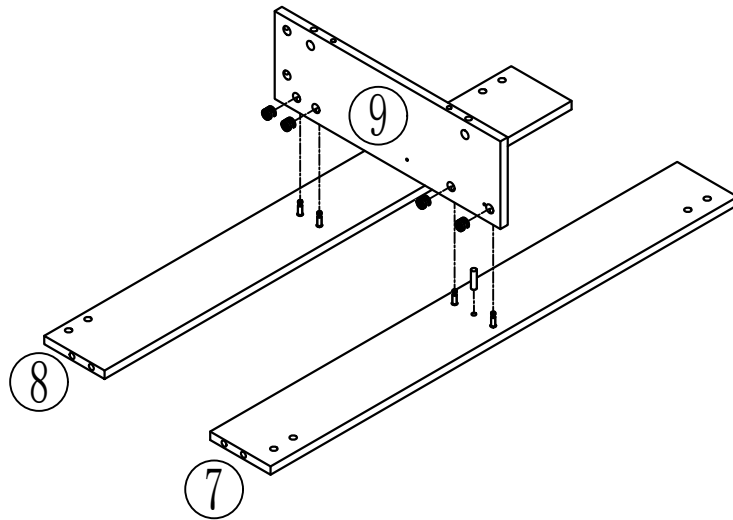
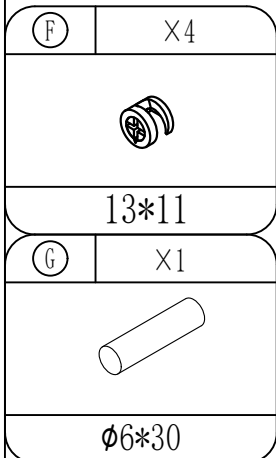

Step 7

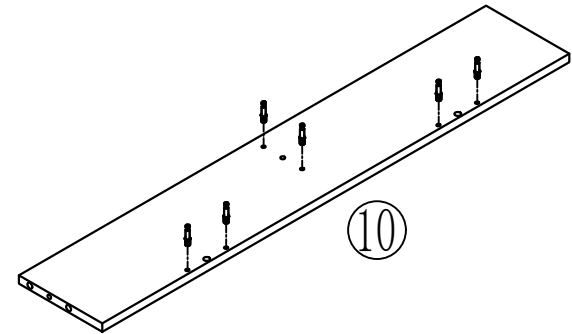
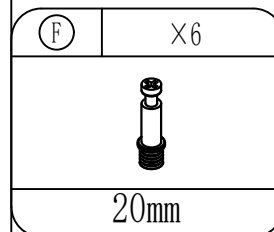

Assembling Instruction

Step 8

(F)	X4	(G)	X1
13*11		ø6*30	

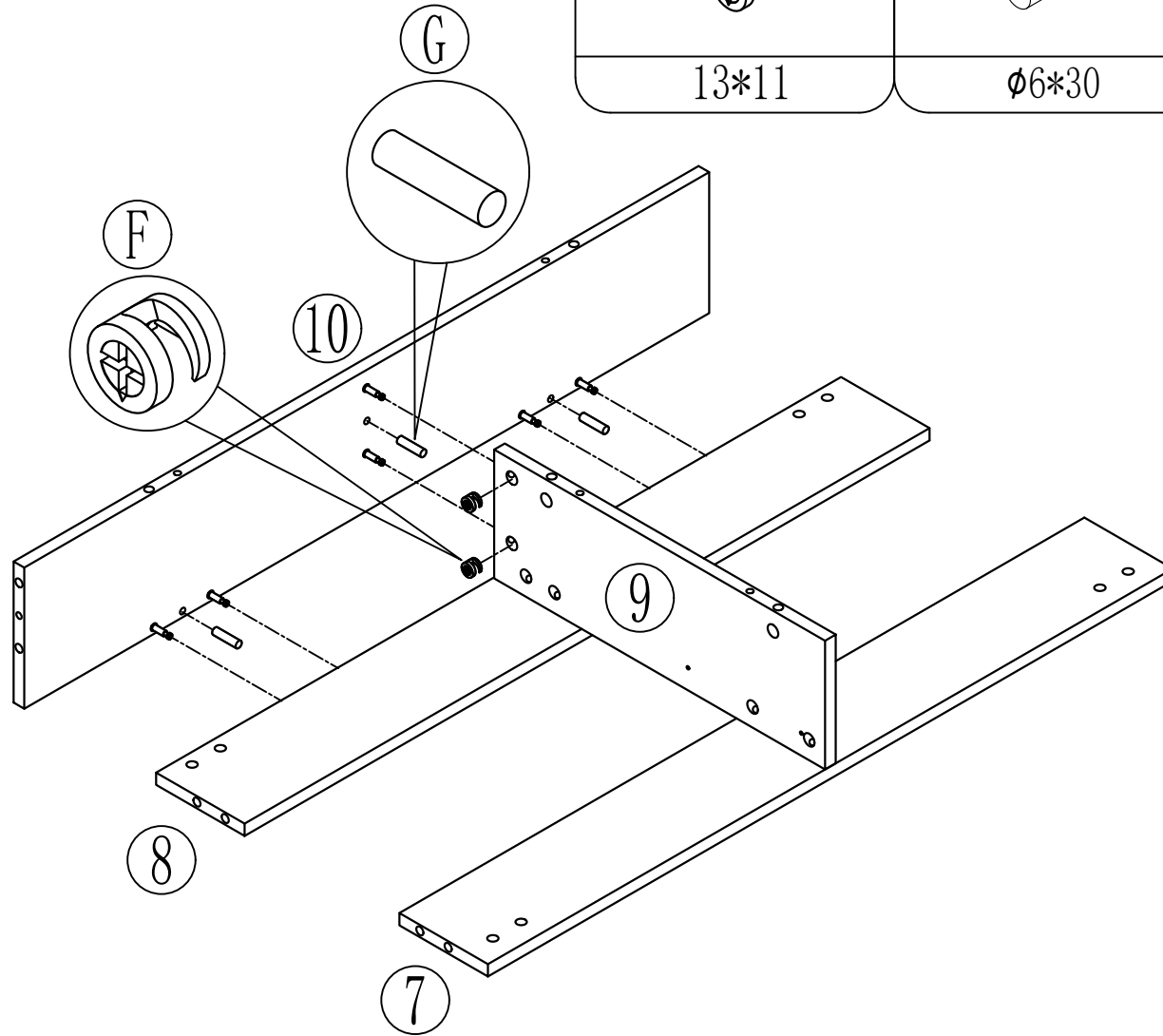

Step 9

(F)	X6
20mm	

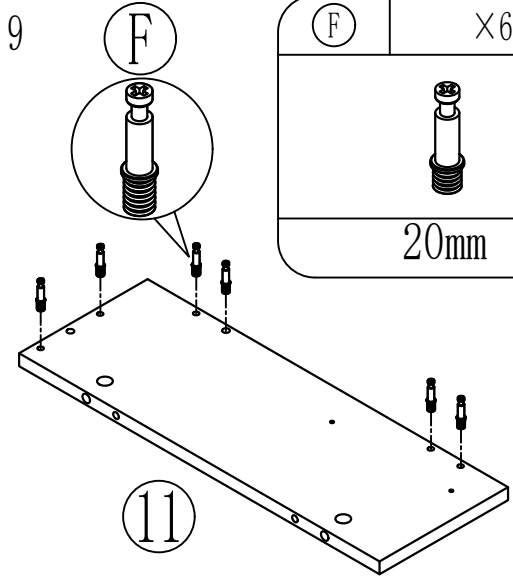

Step 10

(F)	X6
20mm	

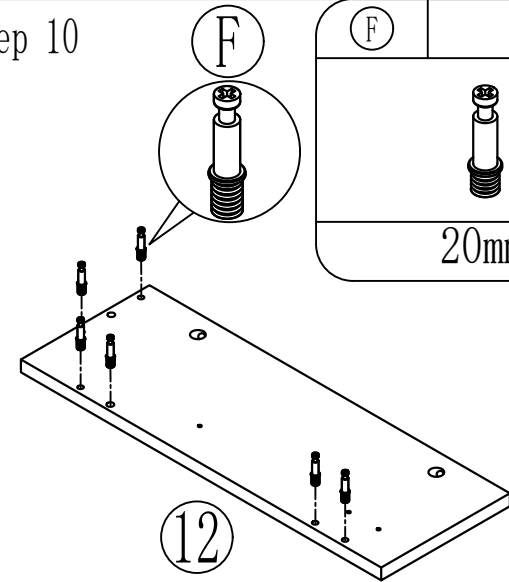

Assembling Instruction

Step 11

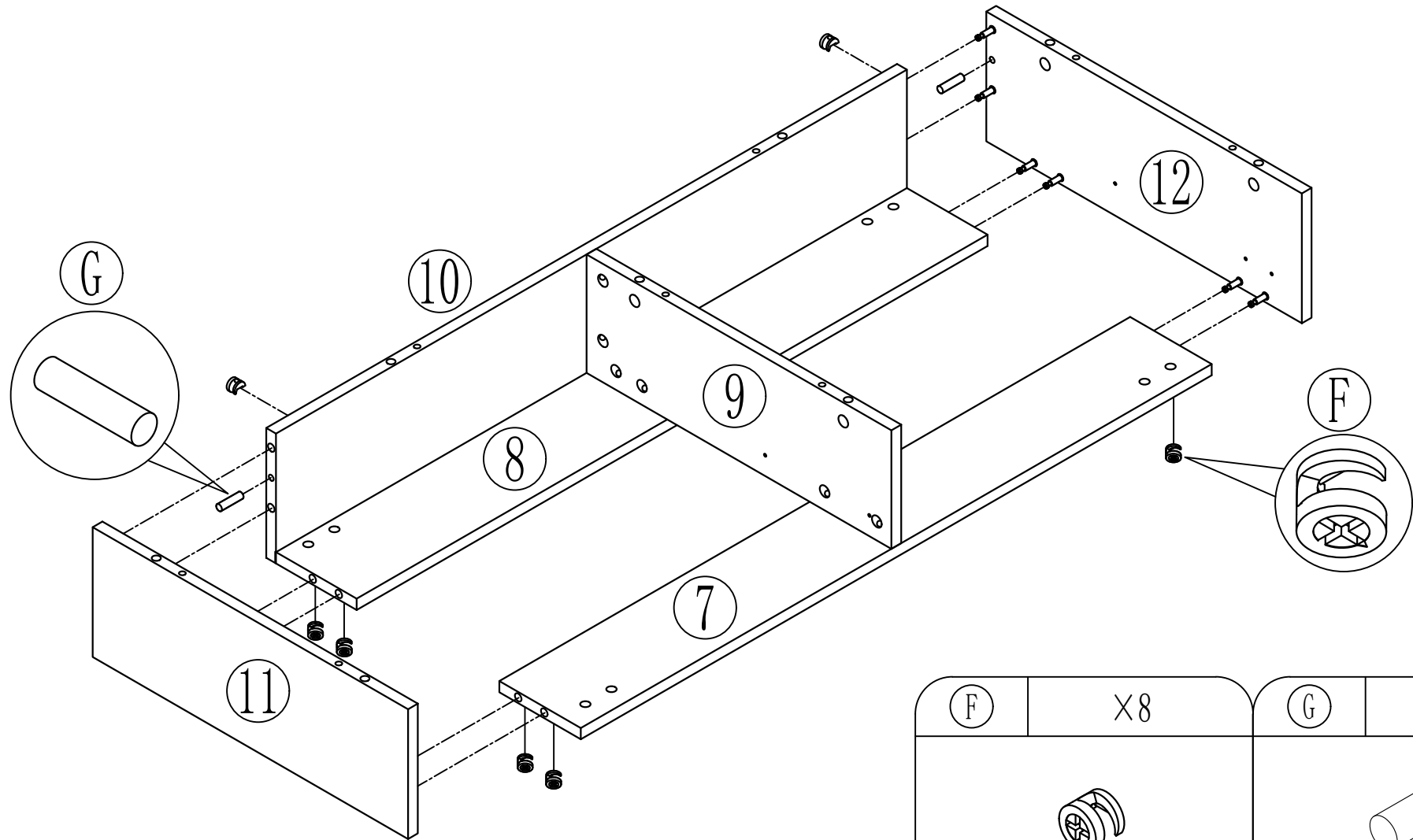

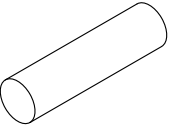
(F)	X8	(G)	X2
			
13*11		Ø6*30	

Assembling Instruction

Step 12

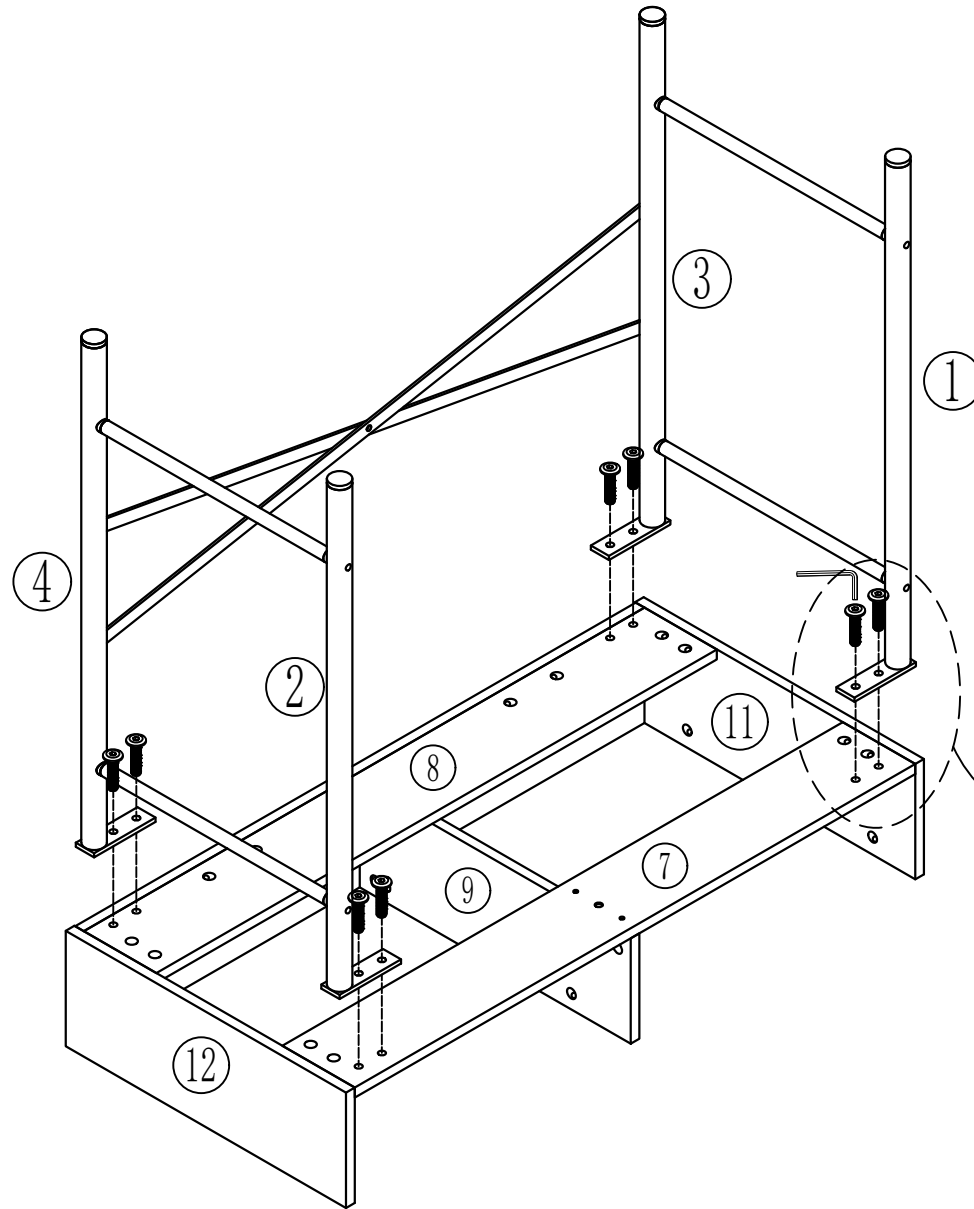

(C)	X1	(D)	X8
S=4		M6*16	

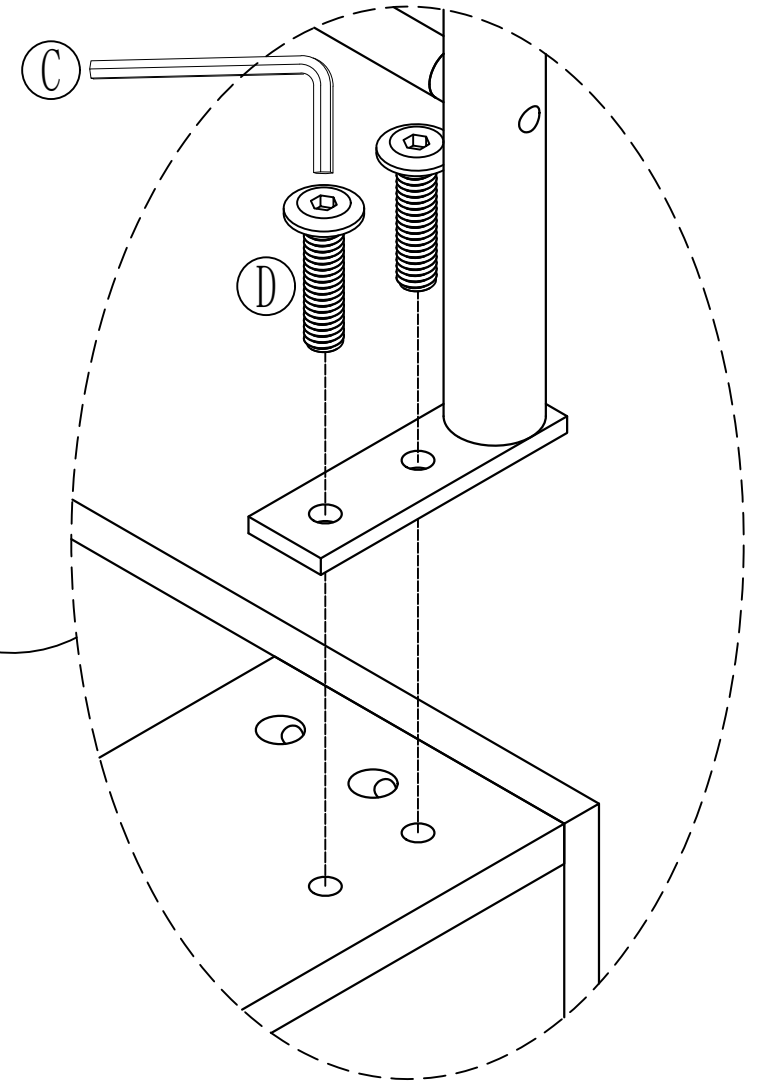

Assembling Instruction

Step 13

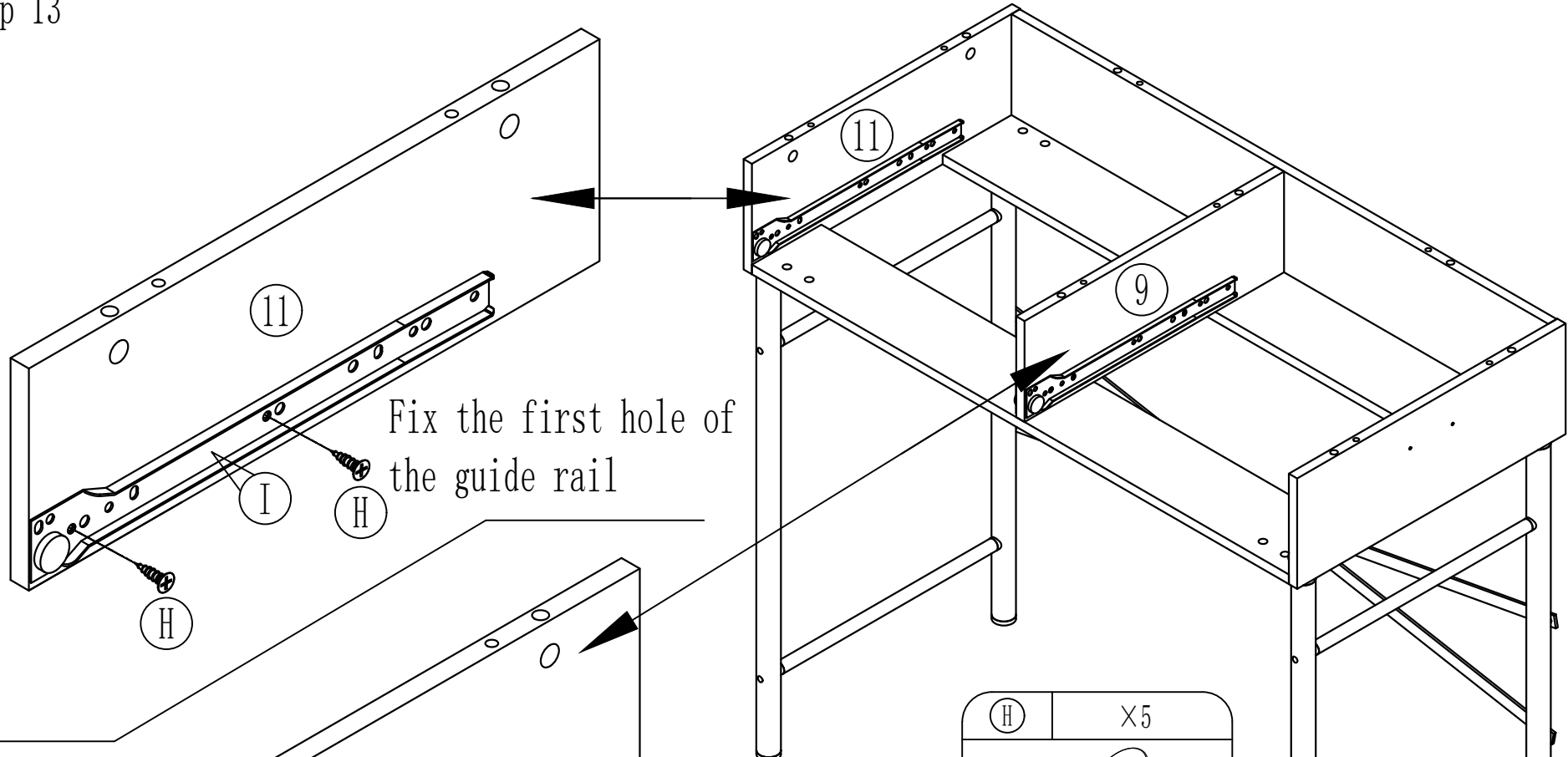

Fix the first hole of the guide rail

Step 14

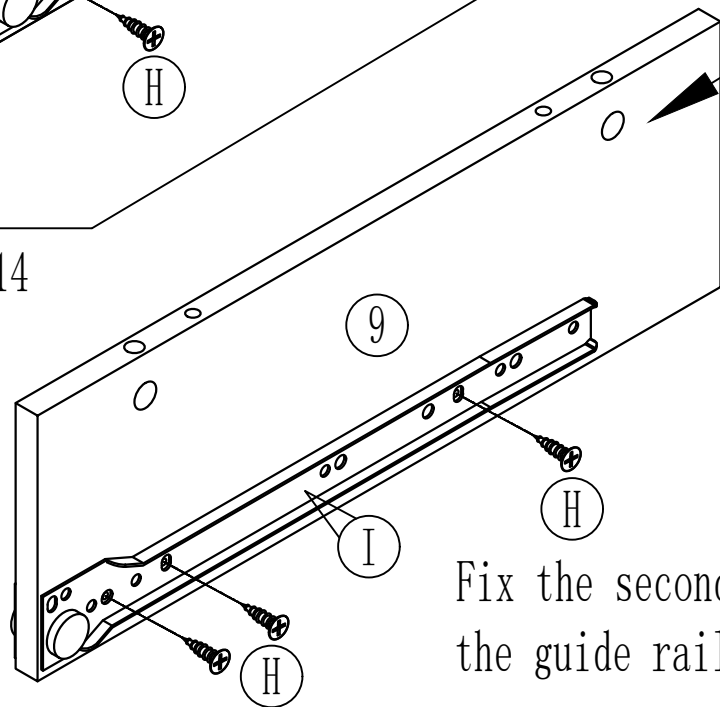

Fix the second hole of the guide rail

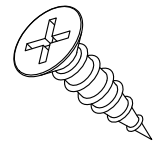
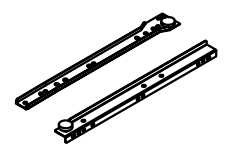
(H)	X5
	
φ 3.5*12	
(I)	X2
	
300MM	

Assembling Instruction

Step 15

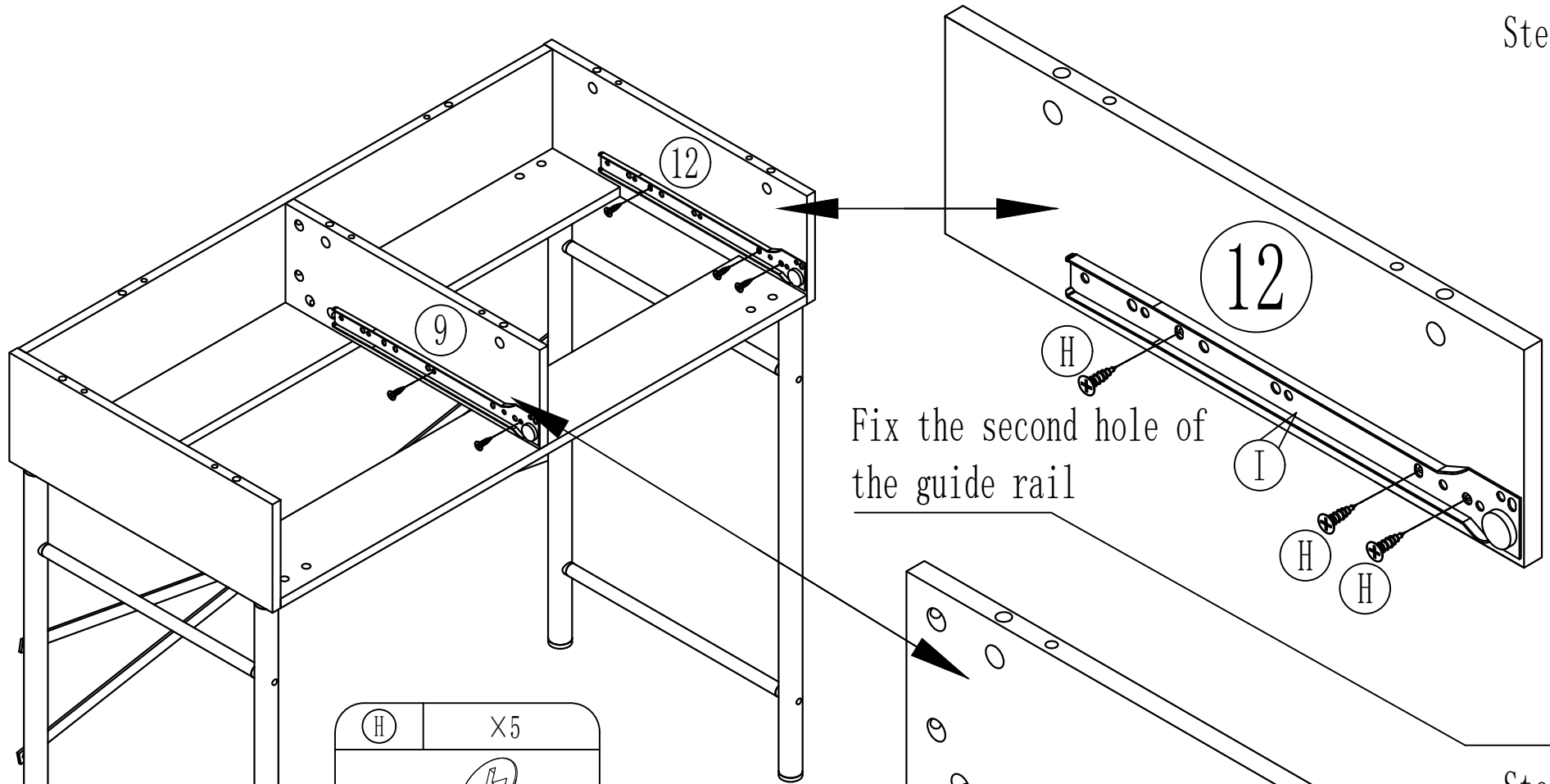

Fix the second hole of the guide rail

Step 16

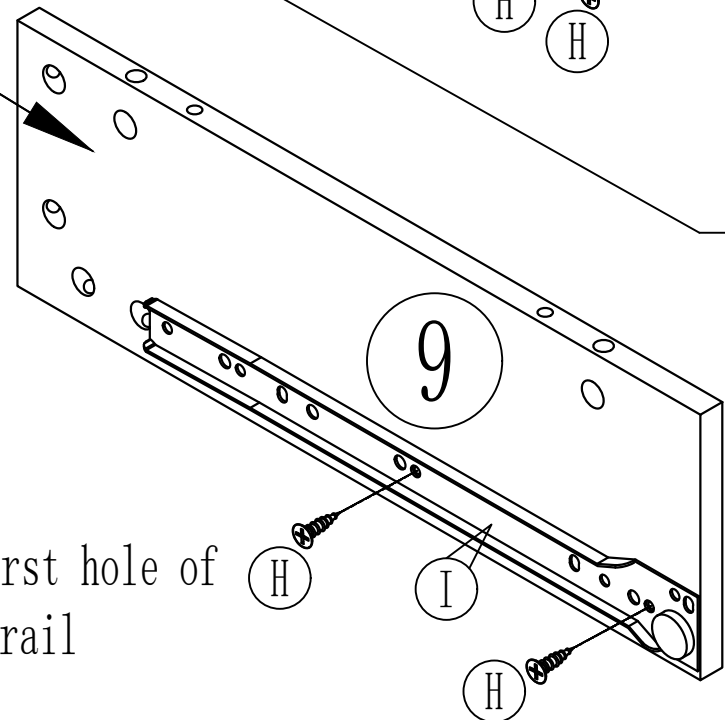

Fix the first hole of the guide rail

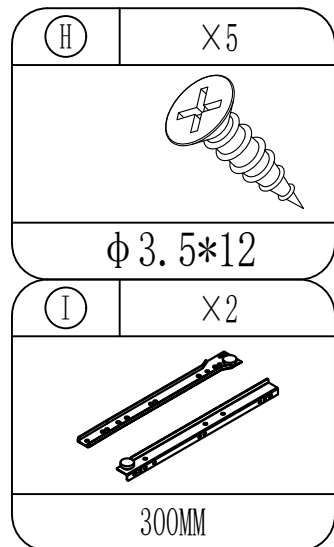

Assembling Instruction

Step 17

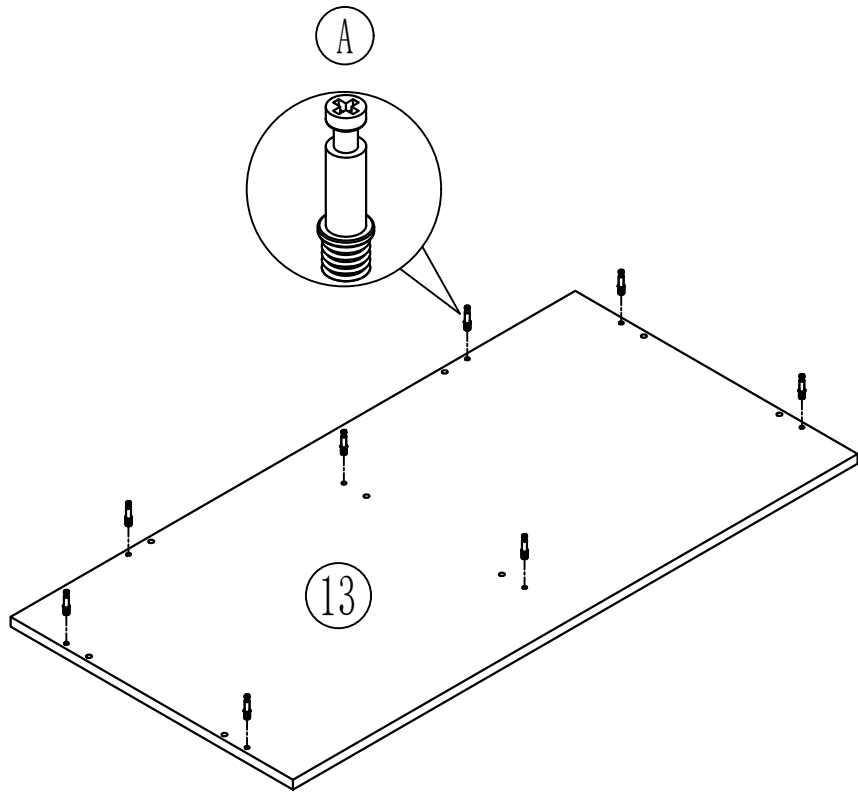

(F)	X8
20MM	

Step 18

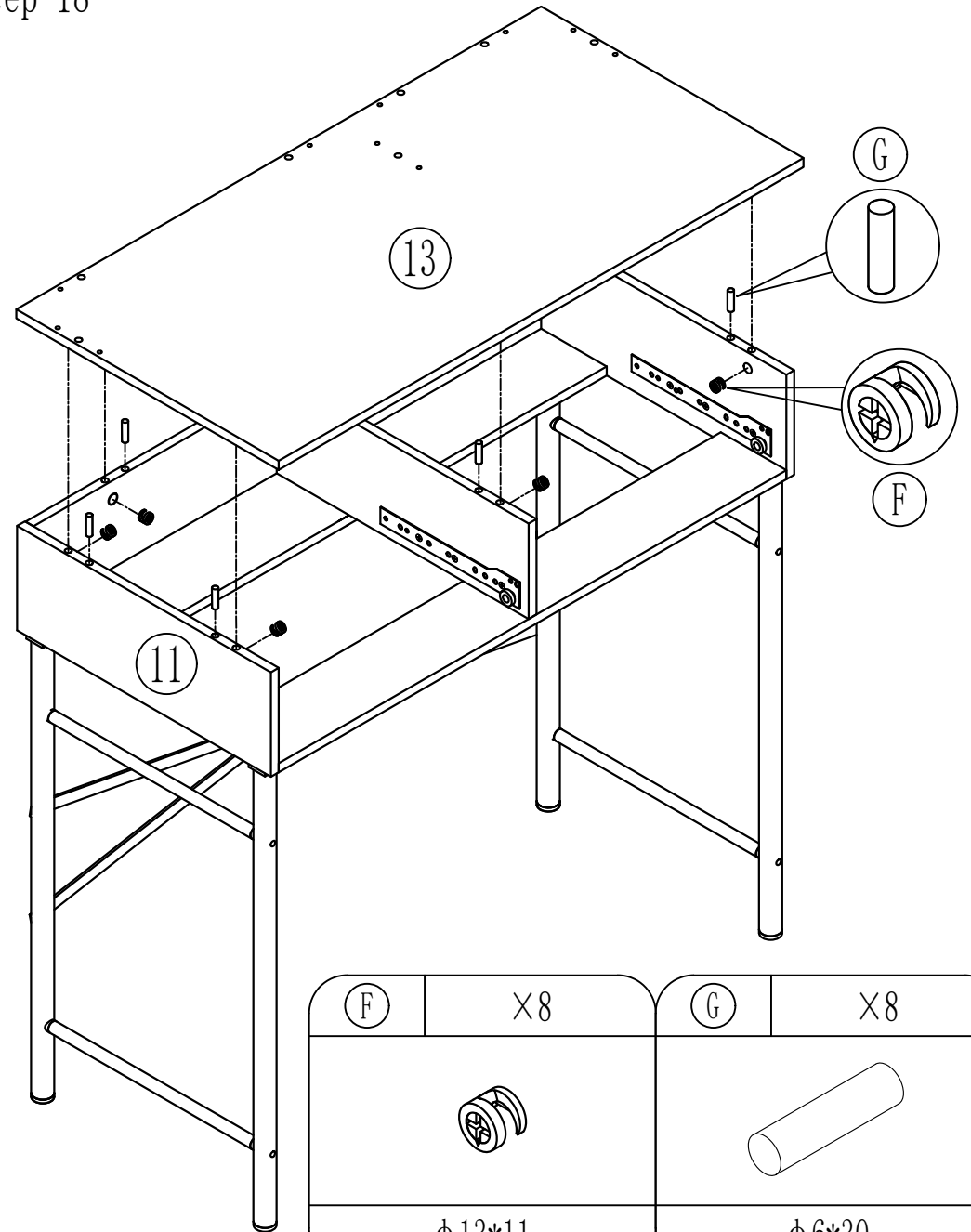

(F)	X8
φ 13*11	

(G)	X8
φ 6*30	

Assembling Instruction

Step 19

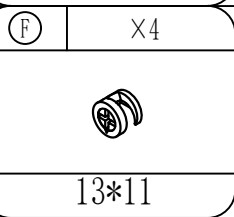
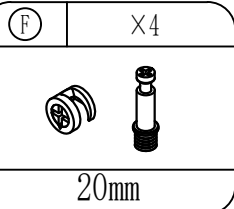
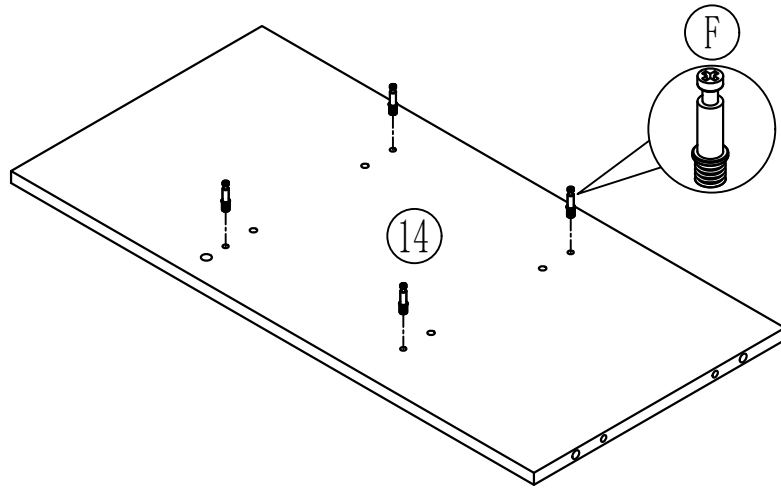

Step 20

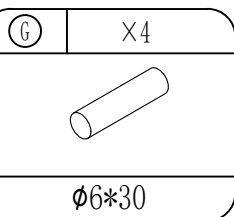
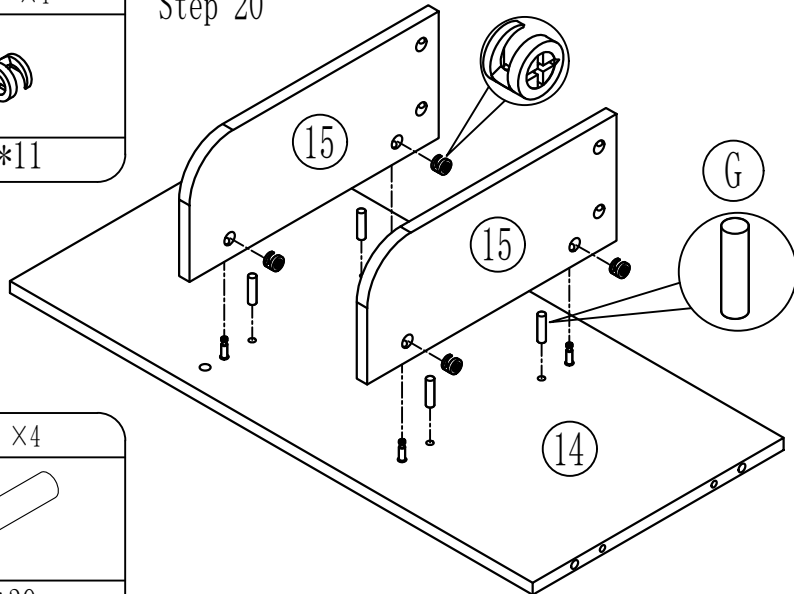

Step 21

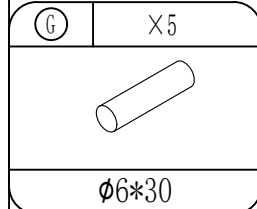
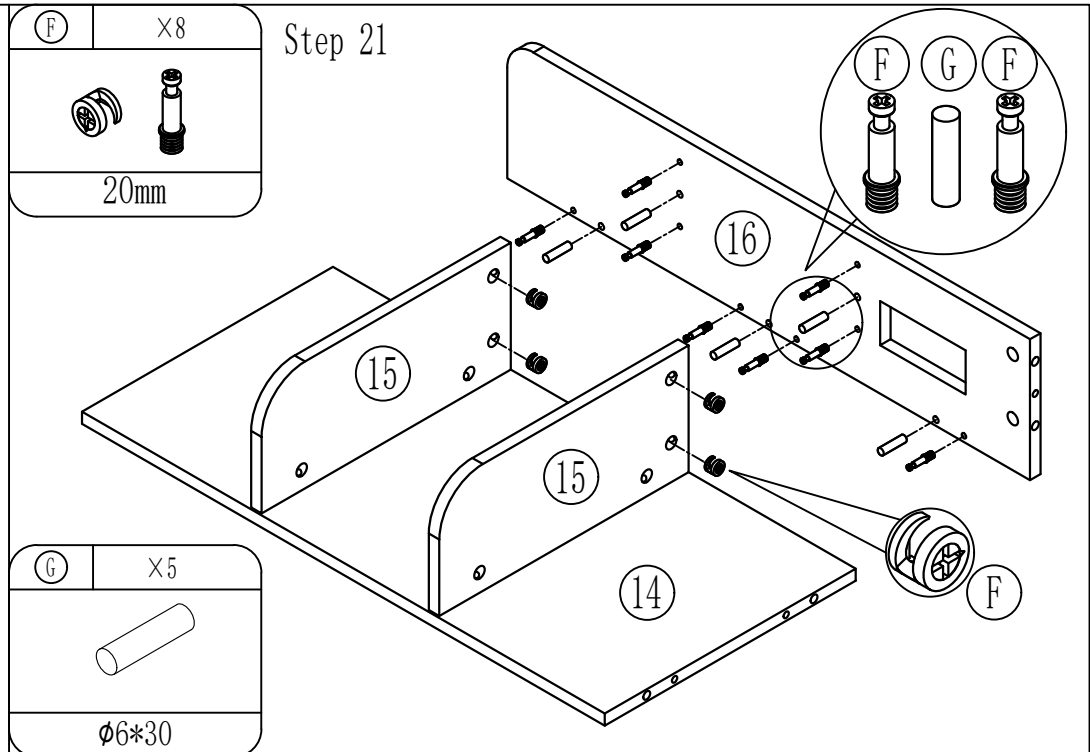

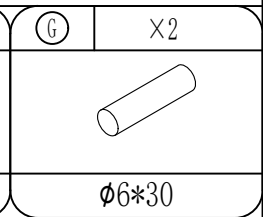
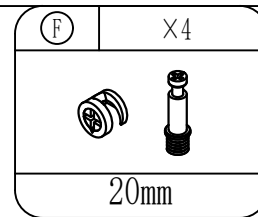
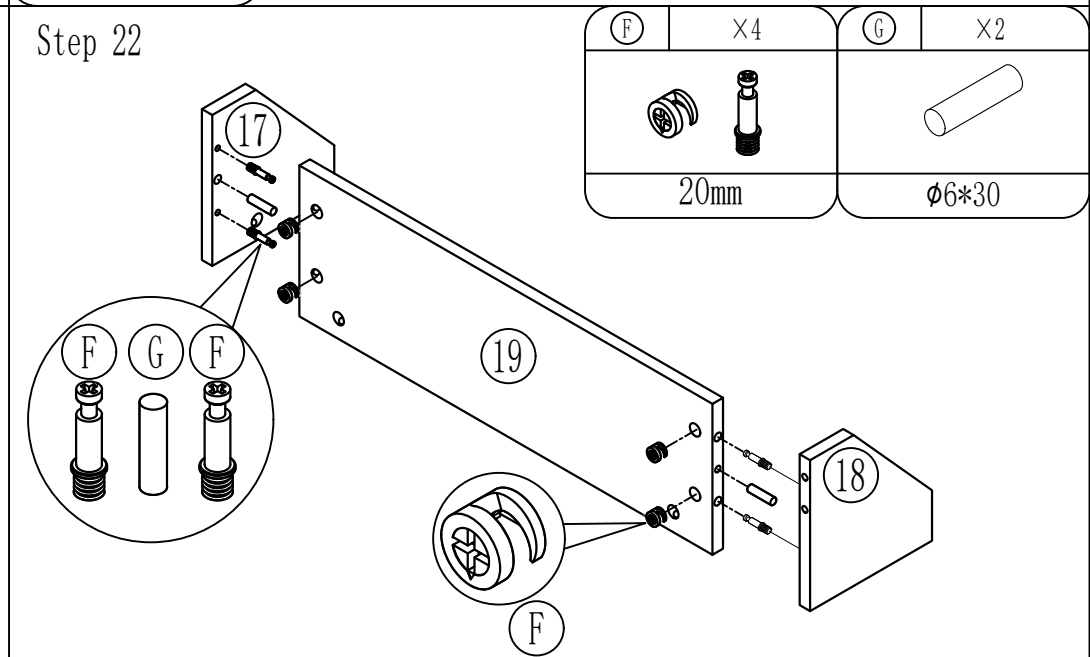

Step 22

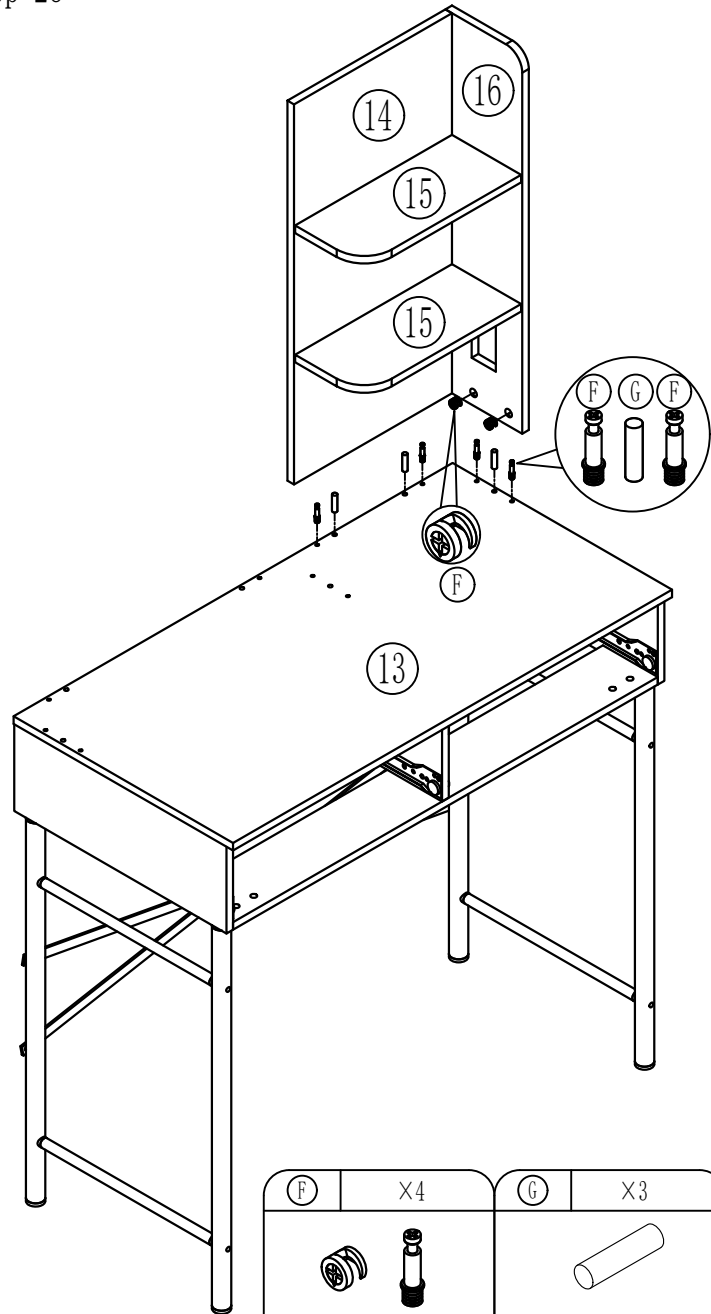

Assembling Instruction

Step 23

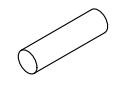

(F)	x4	(G)	x3
			
20mm		φ6*30	

Step 24

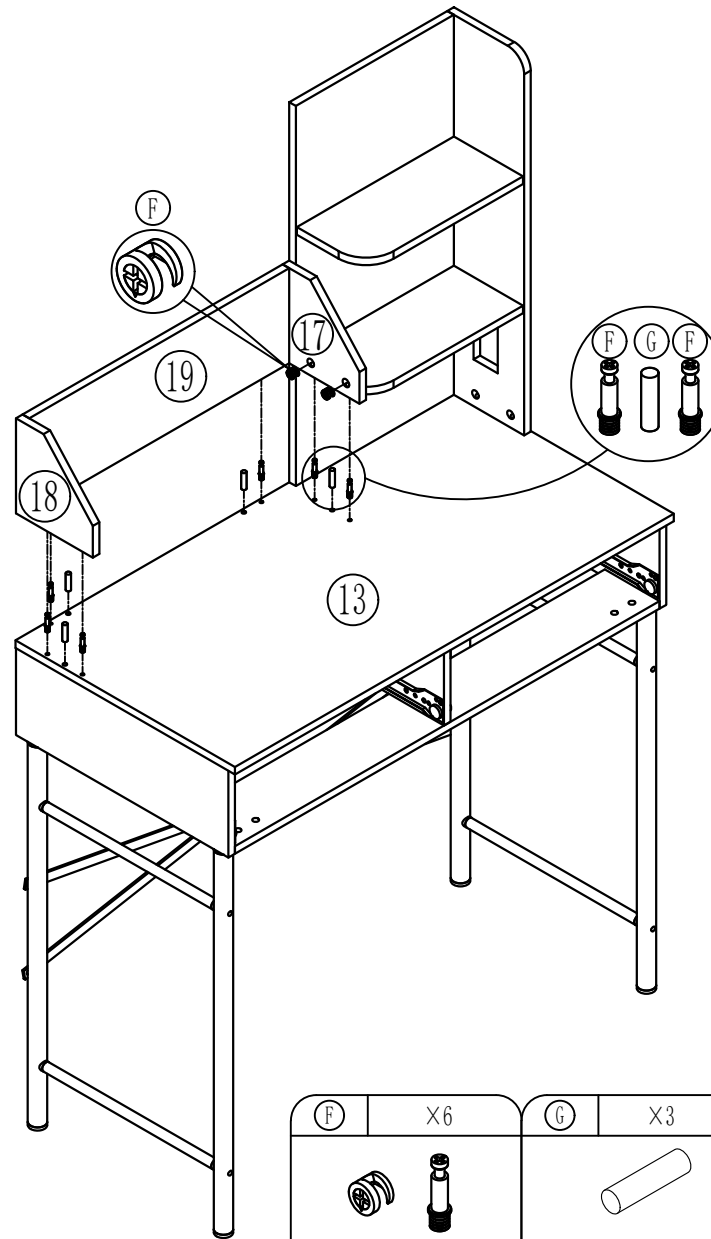

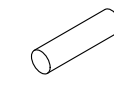
(F)	x6	(G)	x3
			
20mm		φ6*30	

Step 25

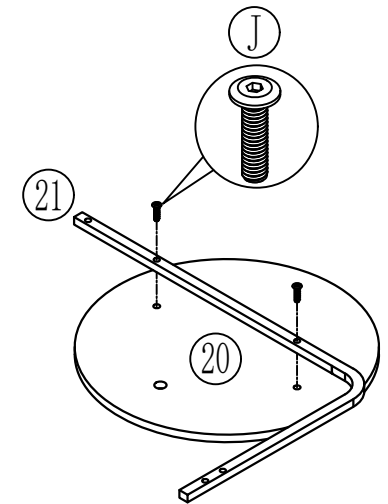



(J)	x2
	
M6*25	

Assembling Instruction

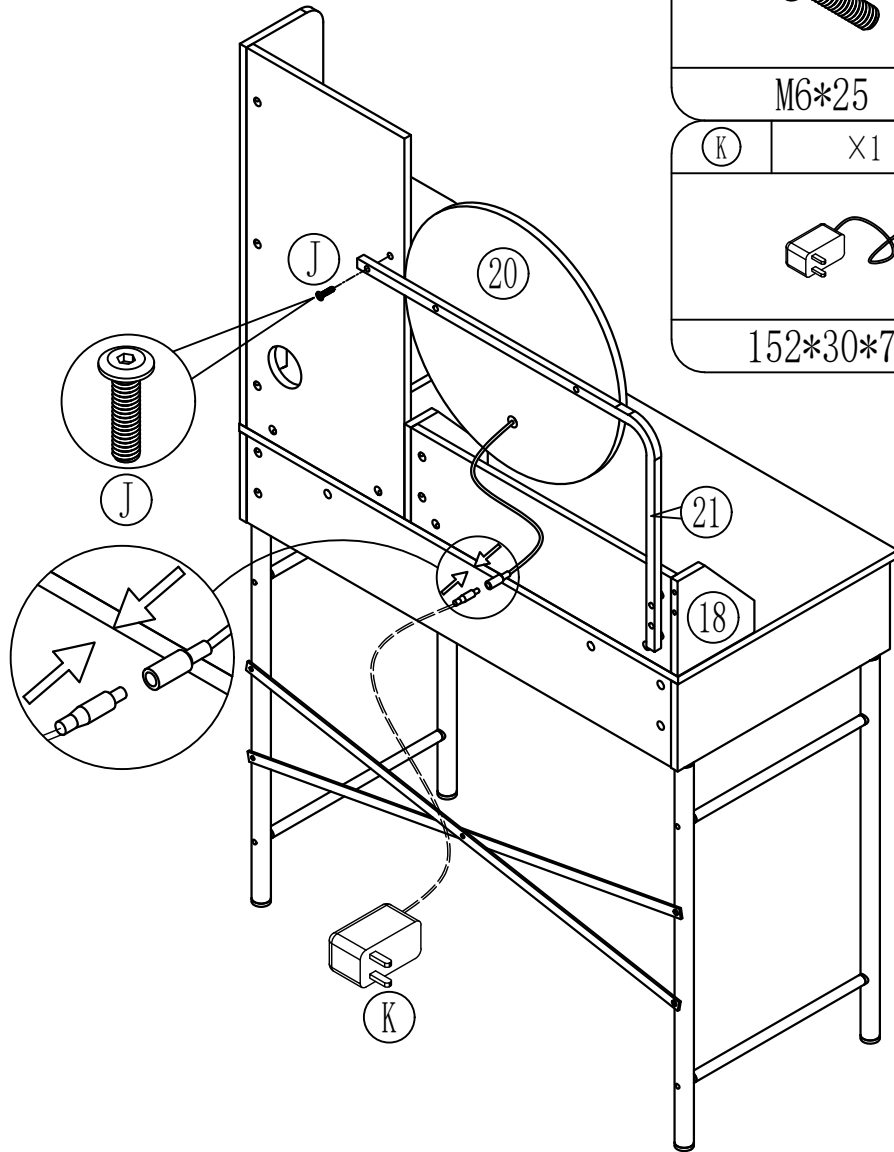

Step 26



(J)	×1
	
M6*25	
(K)	×1
	
152*30*7	

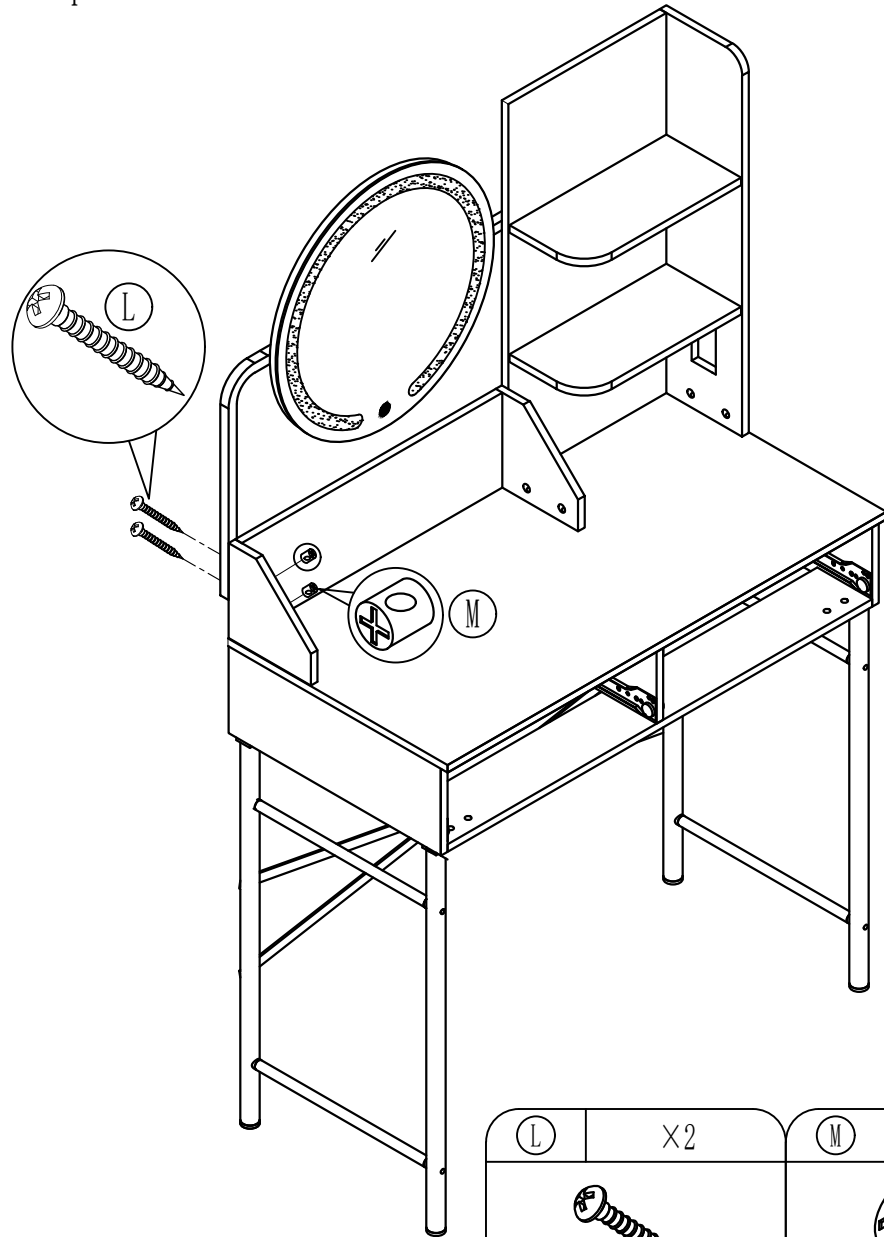

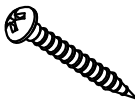
Step 27



(L)	×2	(M)	×2
			
φ 5*45		φ 9*9	

Assembling Instruction

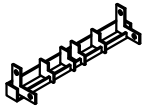
Step 28

(N) ×2	(O) ×4
	
10*10*100	ST3*12

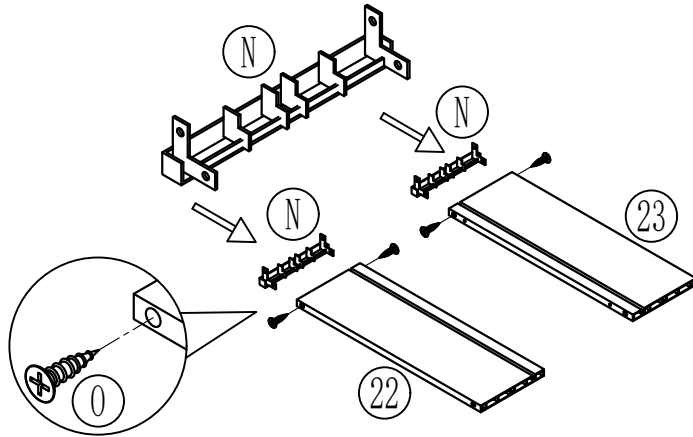

Step 29

(O) ×4

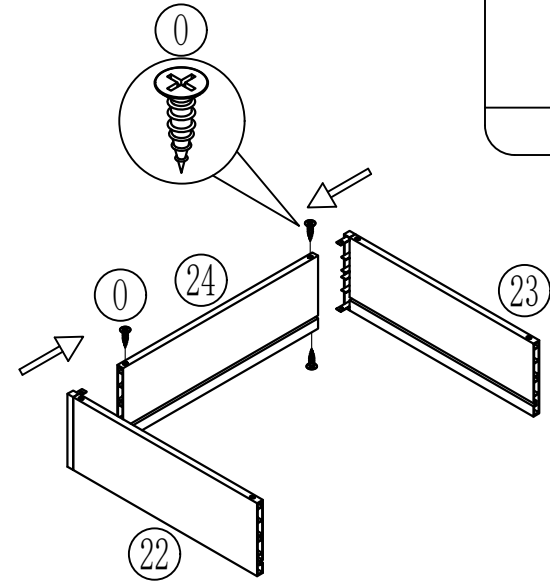
ST3*12

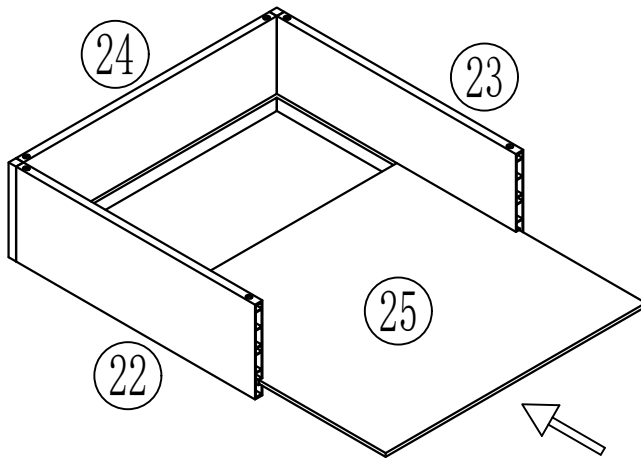

Step 30



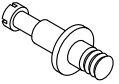



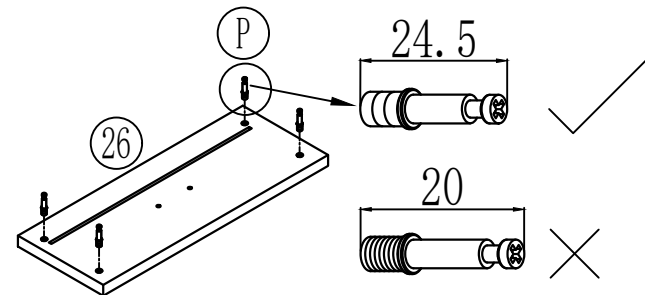
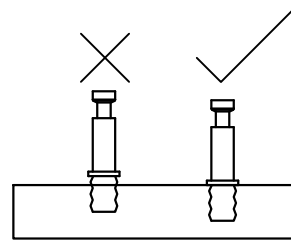

Step 31

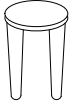
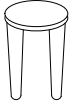
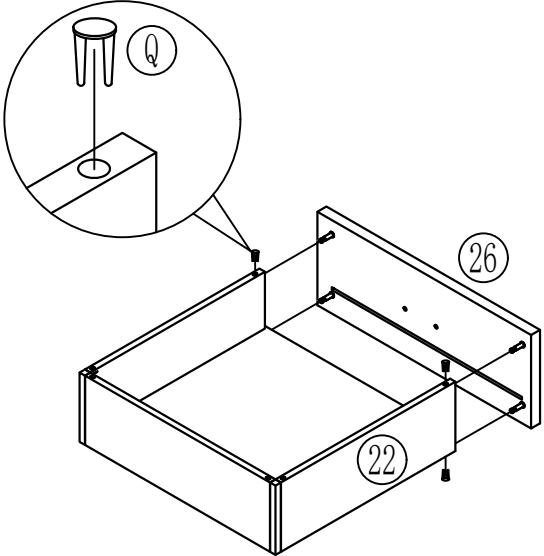
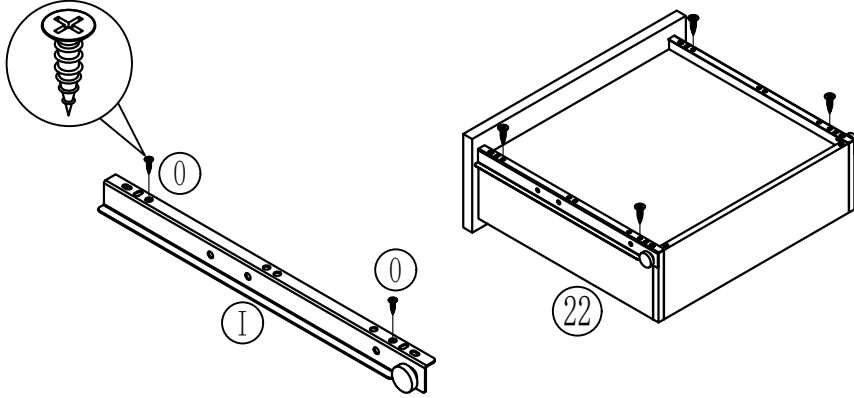
(P)	×4
	
φ7.5*24.5	



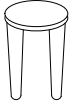

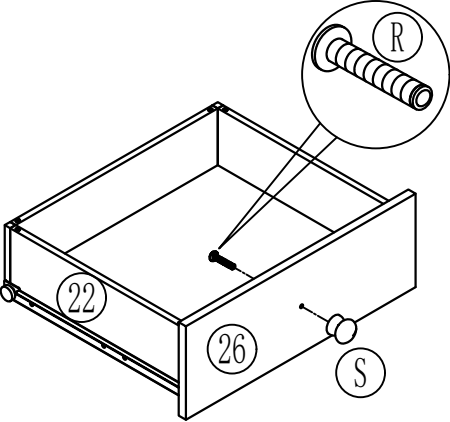
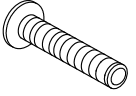
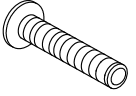
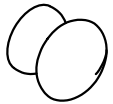
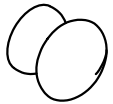
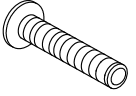
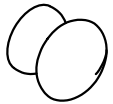
Assembling Instruction

<table border="1"><tr><td>Q</td><td>X4</td></tr><tr><td colspan="2"></td></tr><tr><td colspan="2">φ 8*11</td></tr></table>	Q	X4			φ 8*11		<p>Step 32.1</p> 	<p>Step 32.2</p> 	<table border="1"><tr><td>I</td><td>X1</td></tr><tr><td colspan="2"></td></tr><tr><td colspan="2">300MM</td></tr></table>	I	X1			300MM		<table border="1"><tr><td>O</td><td>X4</td></tr><tr><td colspan="2"></td></tr><tr><td colspan="2">ST3*12</td></tr></table>	O	X4			ST3*12	
Q	X4																					
																						
φ 8*11																						
I	X1																					
																						
300MM																						
O	X4																					
																						
ST3*12																						
<p>Step 33.1</p> 	<table border="1"><tr><td>R</td><td>X1</td></tr><tr><td colspan="2"></td></tr><tr><td colspan="2">M4*20</td></tr></table>	R	X1			M4*20		<table border="1"><tr><td>S</td><td>X1</td></tr><tr><td colspan="2"></td></tr><tr><td colspan="2">φ24*20</td></tr></table>	S	X1			φ24*20									
R	X1																					
																						
M4*20																						
S	X1																					
																						
φ24*20																						

Assembling Instruction

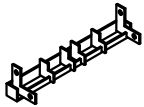
Step 33.2

(N) ×2	(O) ×4
	
10*10*100	ST3*12

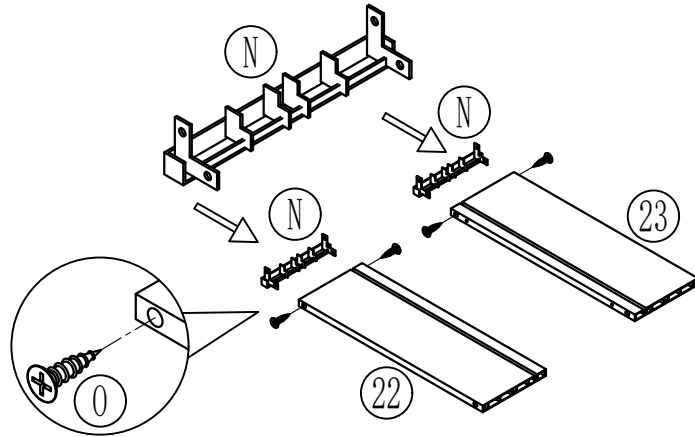

Step 34

(O) ×4

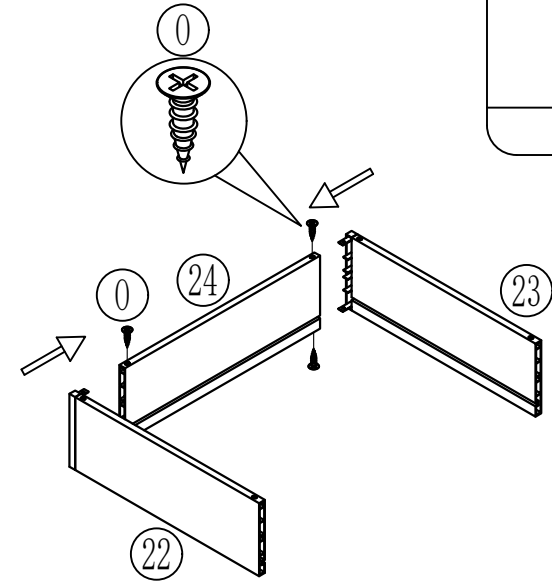
ST3*12

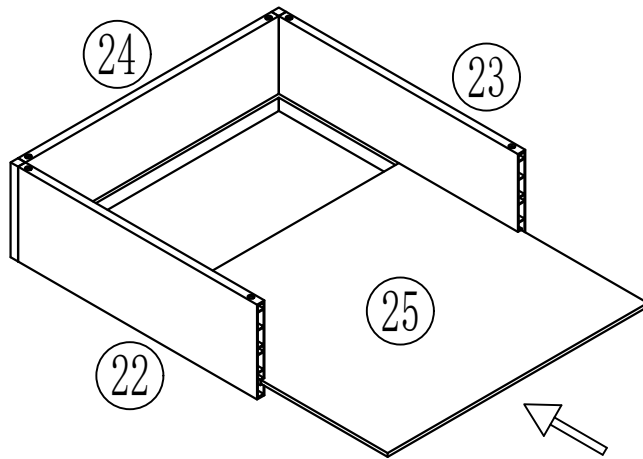

Step 35

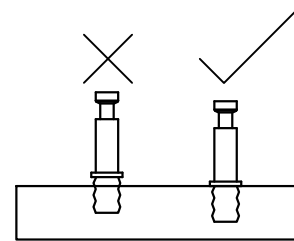

Step 36

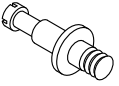

(P)	×4
	
φ7.5*24.5	

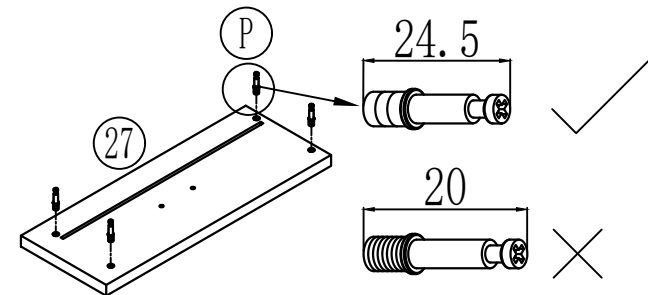

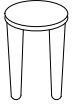

Assembling Instruction

Q	X4
	
φ8*11	

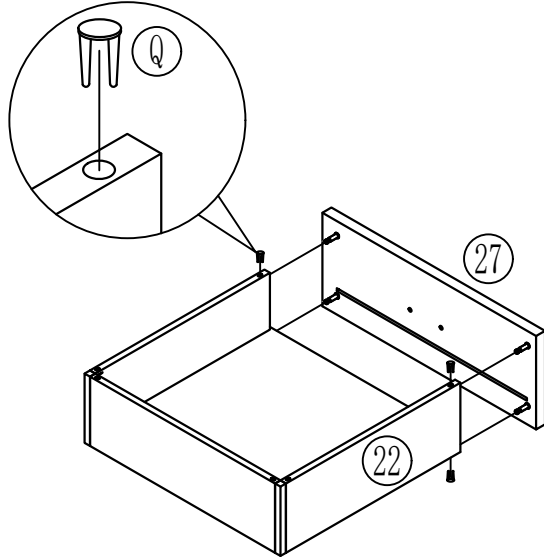
Step 37



Step 38

I	X1	O	X4
			
300MM		ST3*12	

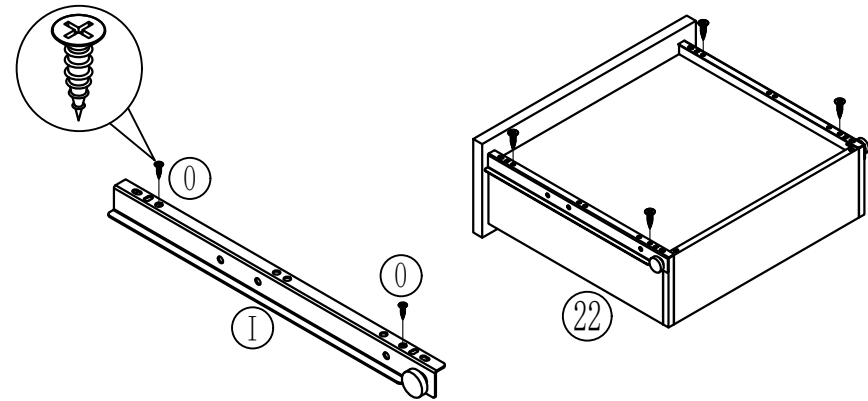

Step 39

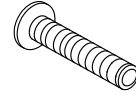
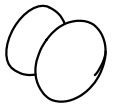
R	X1	S	X1
			
M4*20		φ24*20	

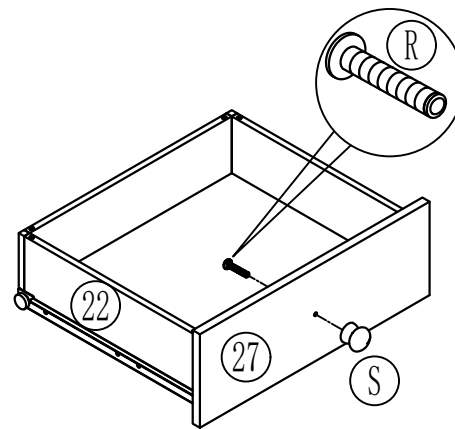

Assembling Instruction

Step 40

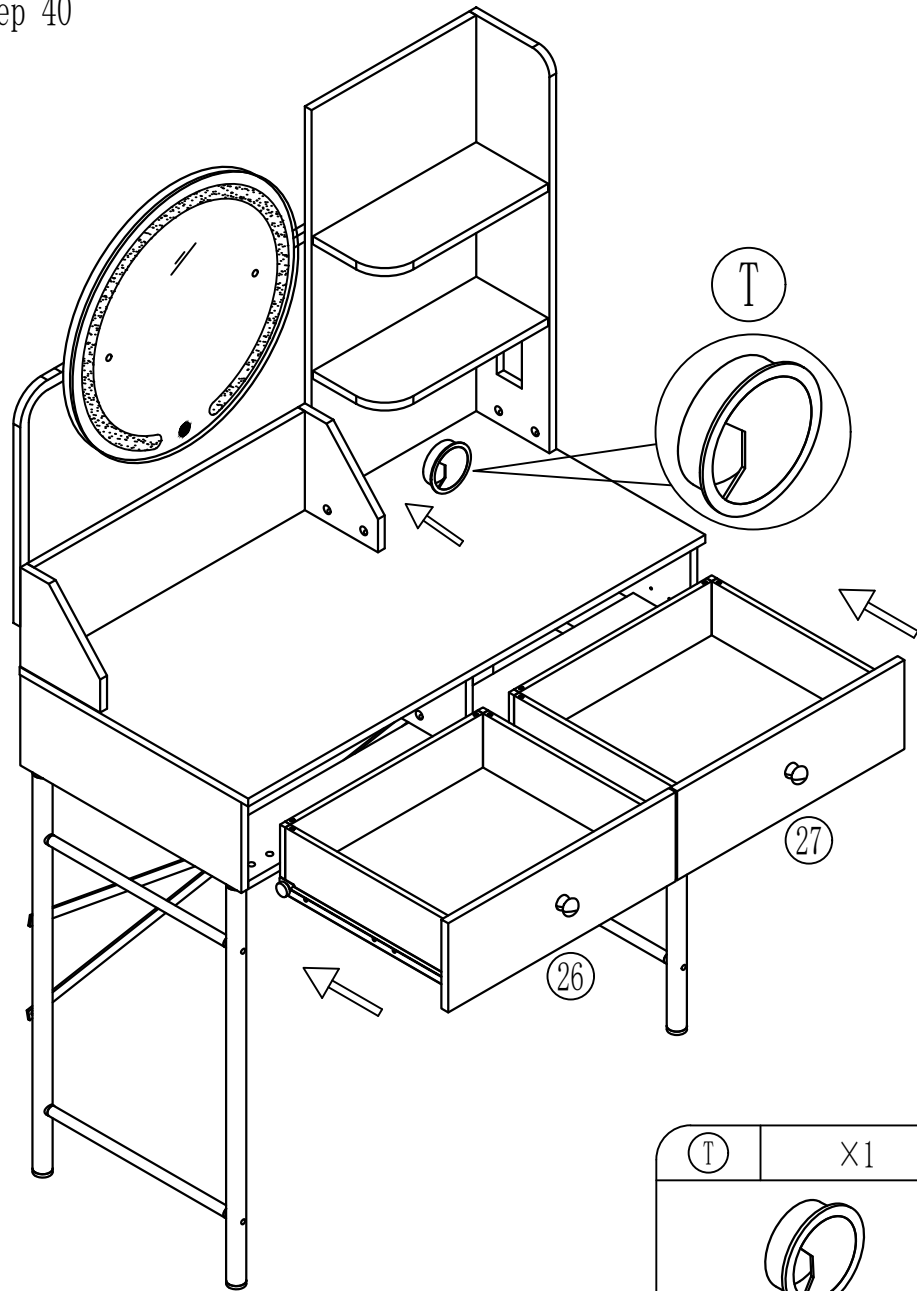

(T)	X1
φ60	

Step 41

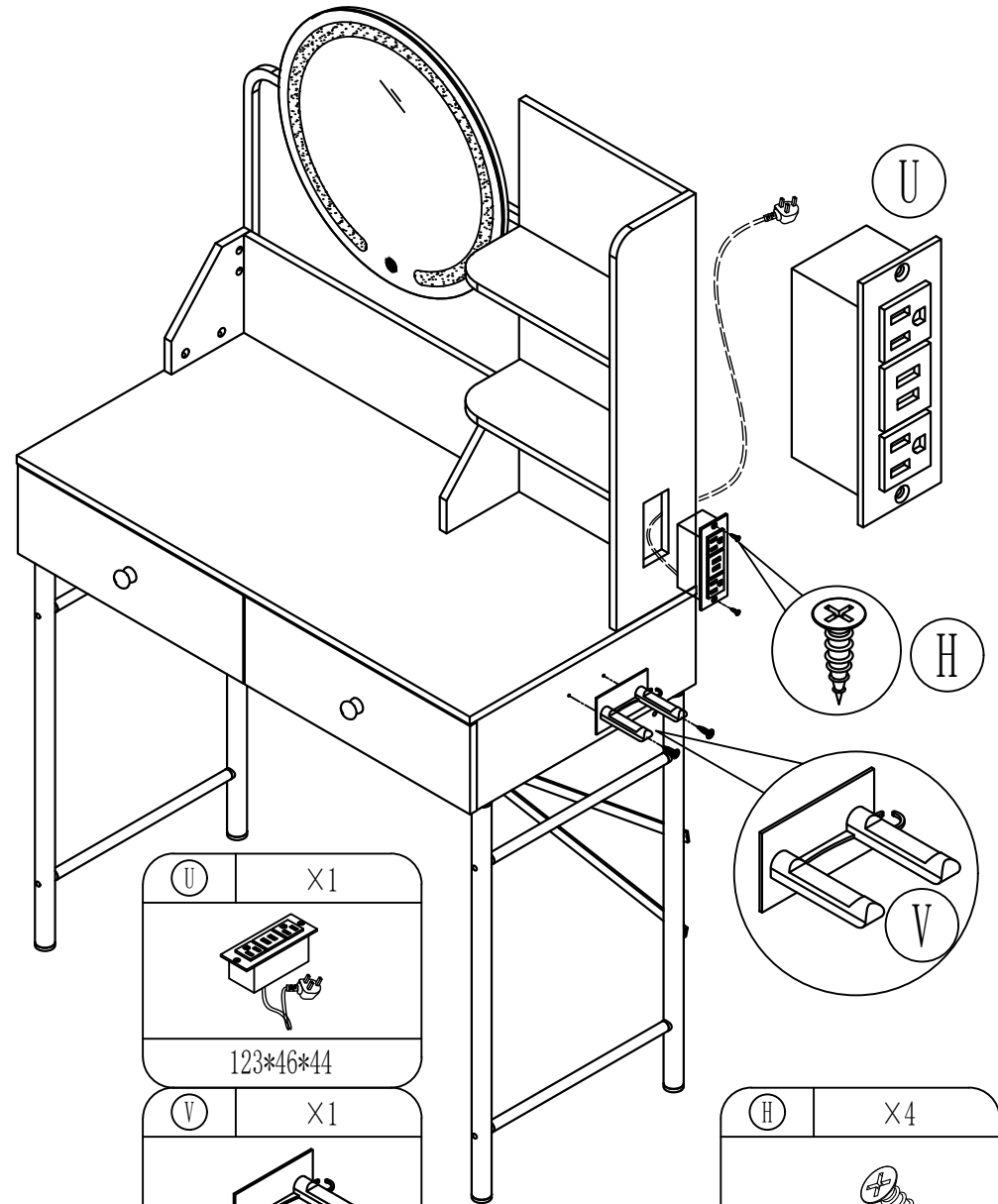

(U)	X1
123*46*44	





(V)	X1
95*50*75	

(H)	X4
φ 3.5*12	

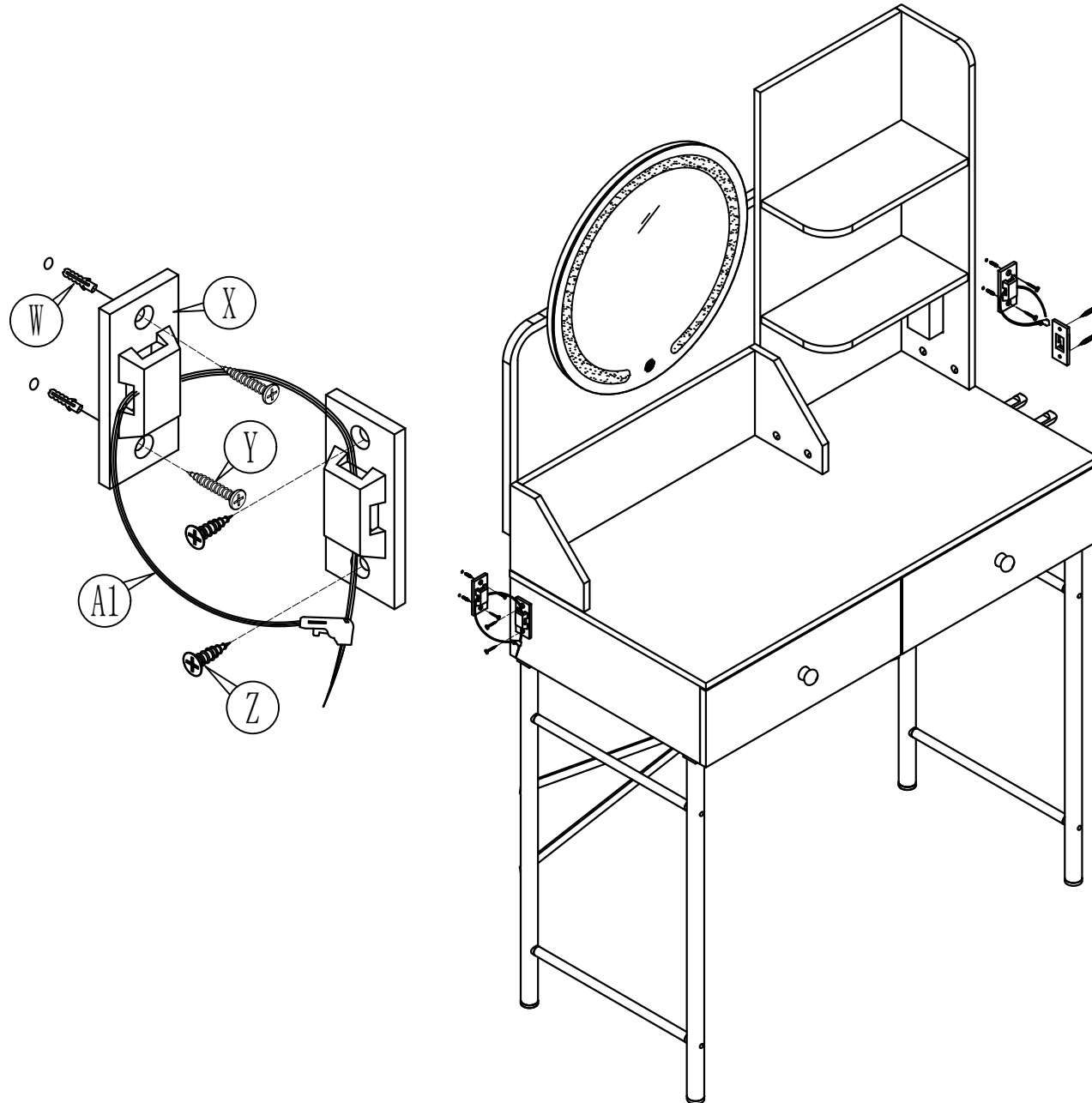
Assembling Instruction

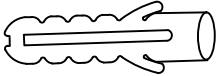
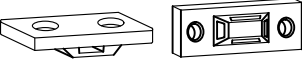
Step 42



(W)	×4
	
φ 8*34	
(X)	×4
	
19*42*8	
(Y)	×4
	
φ 4*35	
(Z)	×4
	
φ 3.5*12	
(A1)	×2
	
245*7*1	