

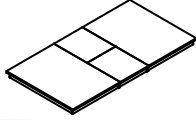

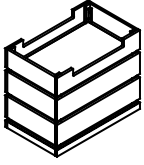



Assembly Instruction

SOLID TOP EXTENSION STORAGE WITH HI-LOW CONVERTIBLE BASE

NO	PART LIST		Q'TY
A		Table Top	1 Pce
B		Base	1 Pce

No	Hardware List		Qty
1		Hex Nut 5/16"	4 pcs
2		Lock Washer M8X13.5mm	4 pcs
3		Flat Washer M8.5X18.5X1.8mm	4 pcs
4		Wrench 12.8mm	1pce
5		Allen Key M5	1pce

Important Note

Need 2 adult to flip over the assembled table. Do not lean any weight on table leg during the flipping process.

STEP 1

Assembled base for Counter Height Table, If want it to be Dining Height Table, please remove the filler as shown.

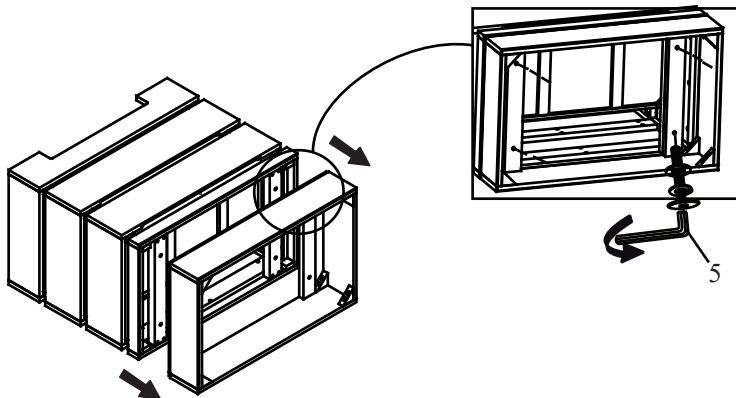

STEP 2

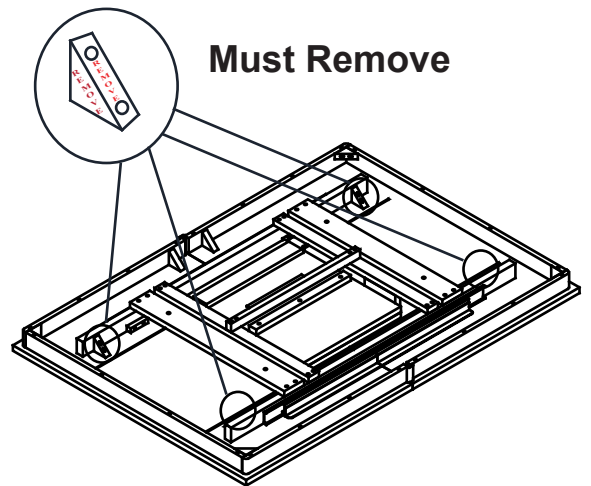

STEP 3

Required 2 persons to lift and position the table to table base.

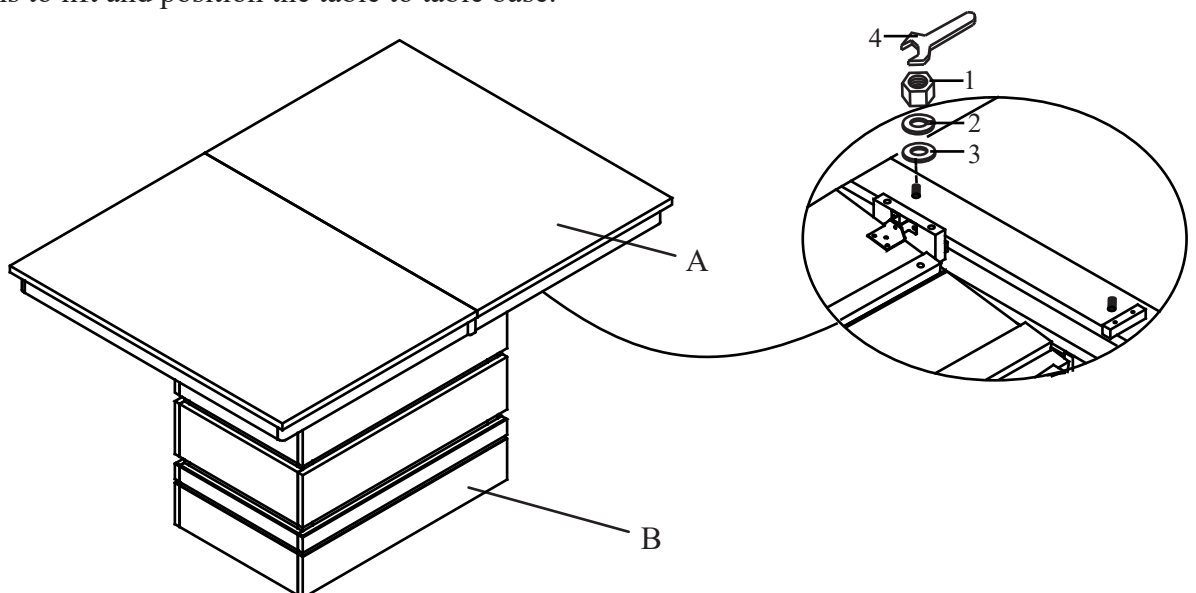

Assembly Instruction

SOLID TOP EXTENSION STORAGE WITH HI-LOW CONVERTIBLE BASE

STEP 4

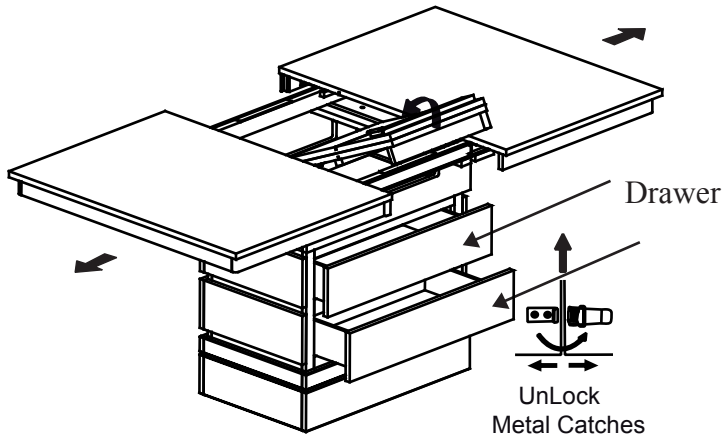

STEP 5

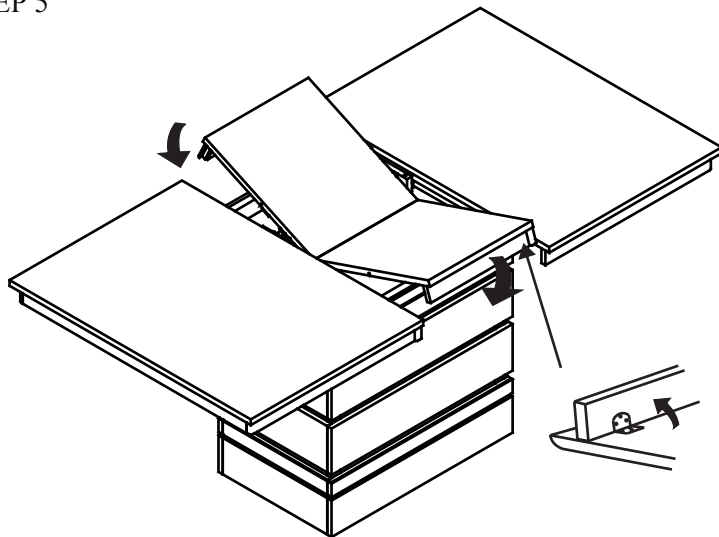

STEP 6

