

Assembly Instructions

909220 Fluted Door Corner Entertainment - Rustic OAK
909226 Fluted Door Corner Entertainment - Smoked OAK

Product Issues? Please Call Us Before Contacting Your Retailer At 1-800-549-3300

Email customerservice@mshome.co, or visit www.mshome.co

We can help with Assembly Issues, Part Requests, Damages, & All Other Product

Related Questions

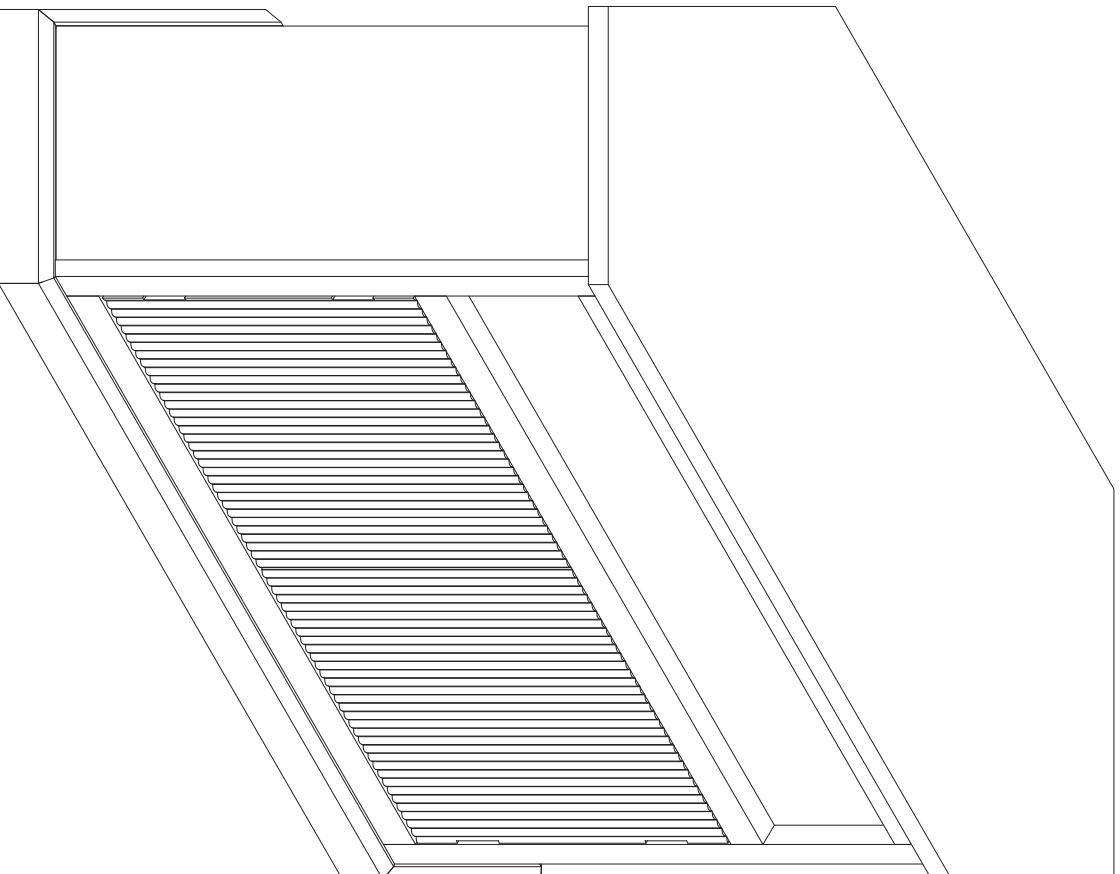

MSH - USA

1-7

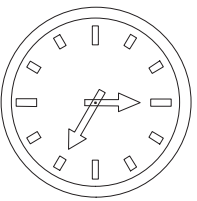

20 min

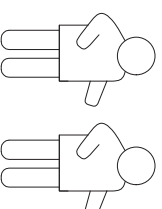

Two People Required
for Assembly

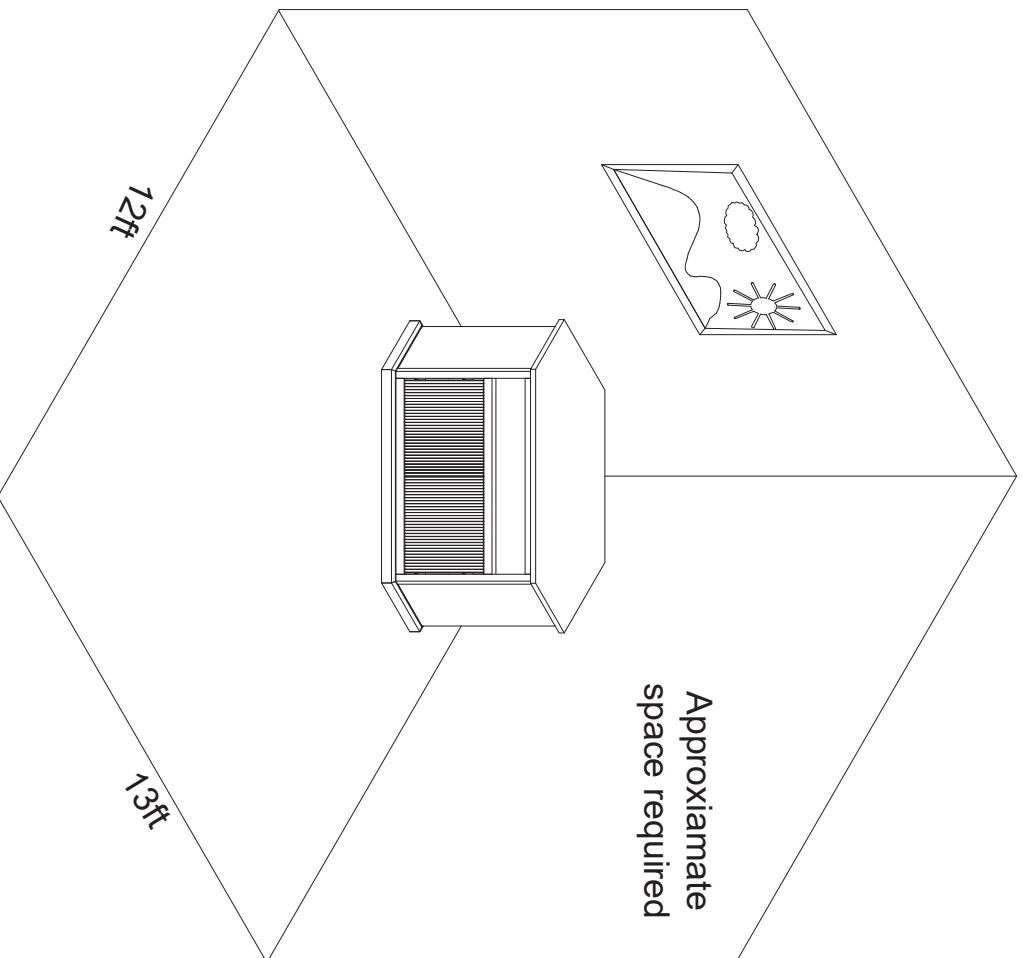

Do Not Use Power Tools

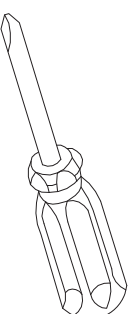

Phillips Head
Not Provide

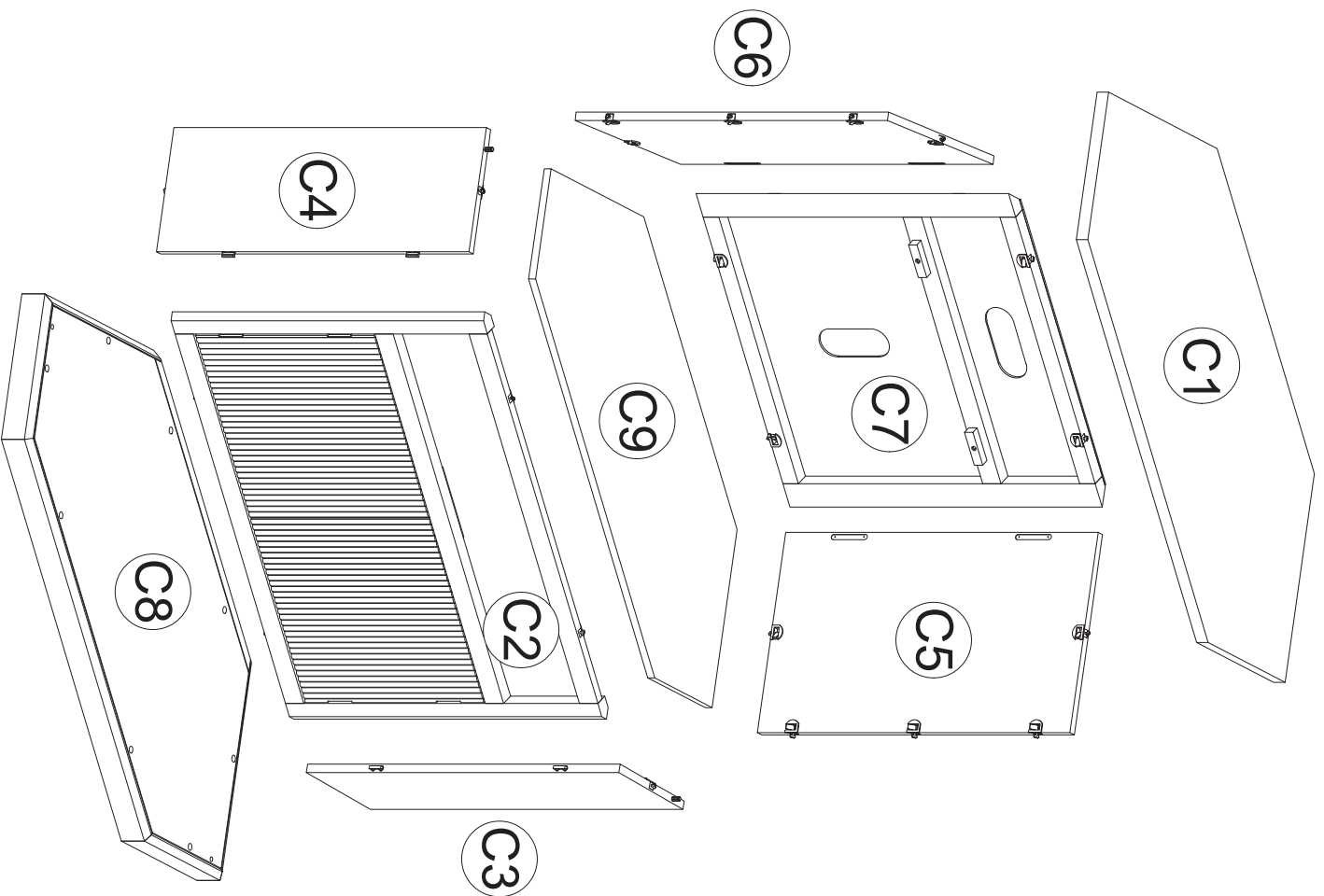

Hardware Pack:

A



3

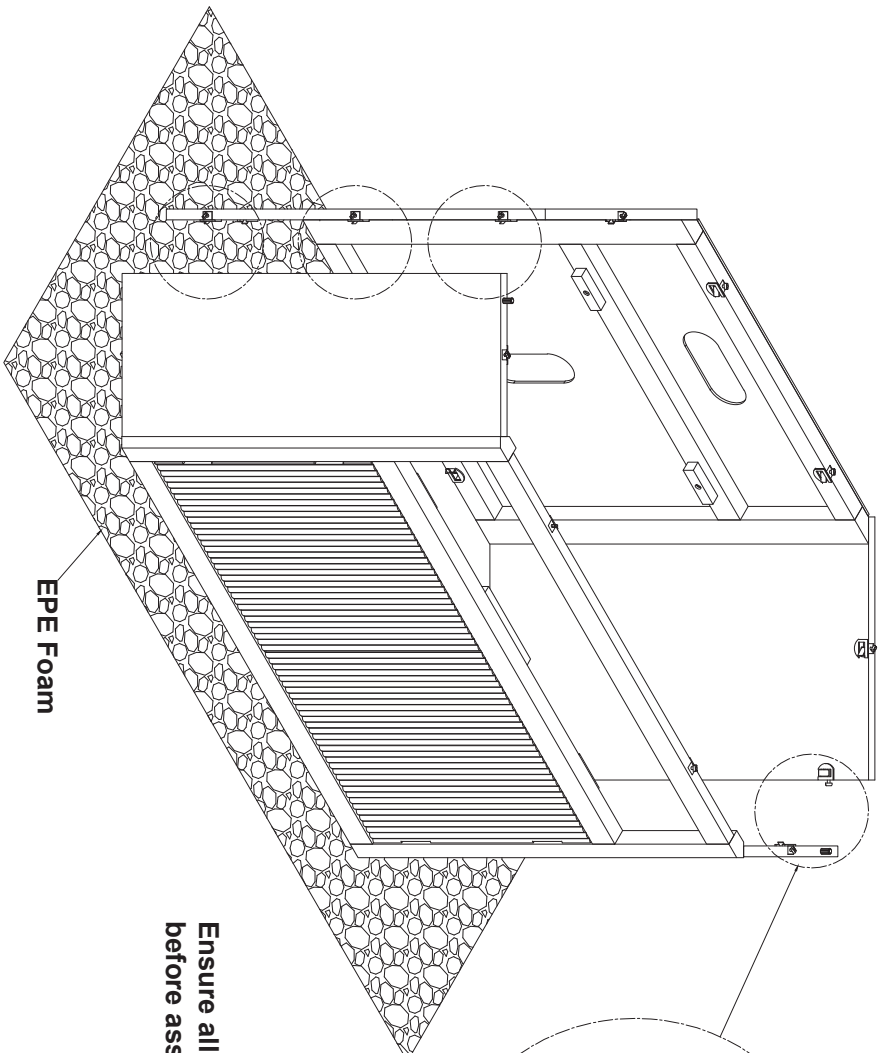

Ensure all latches are open before assembling front and rear frames.

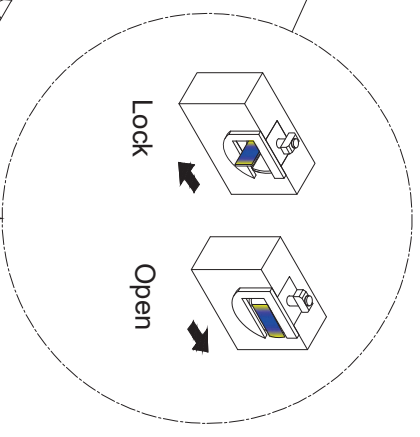

4

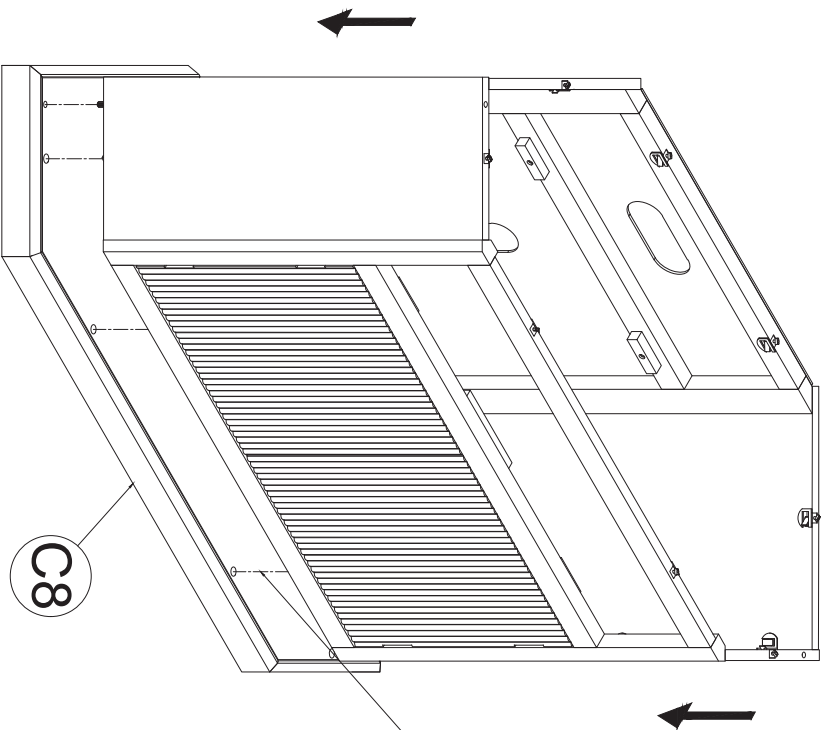

5-7

Make sure all latches are in the open position before installing Bottom Panel (C8)

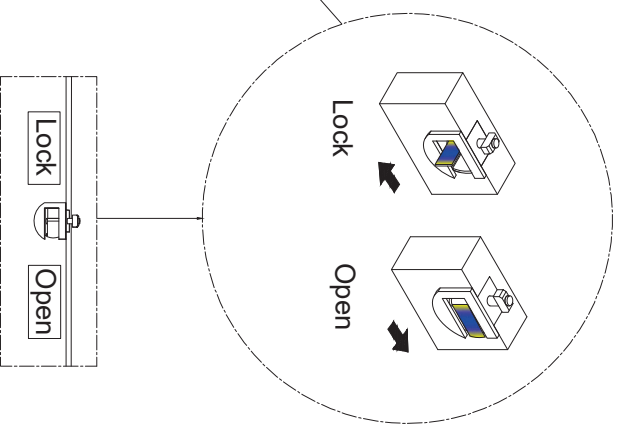

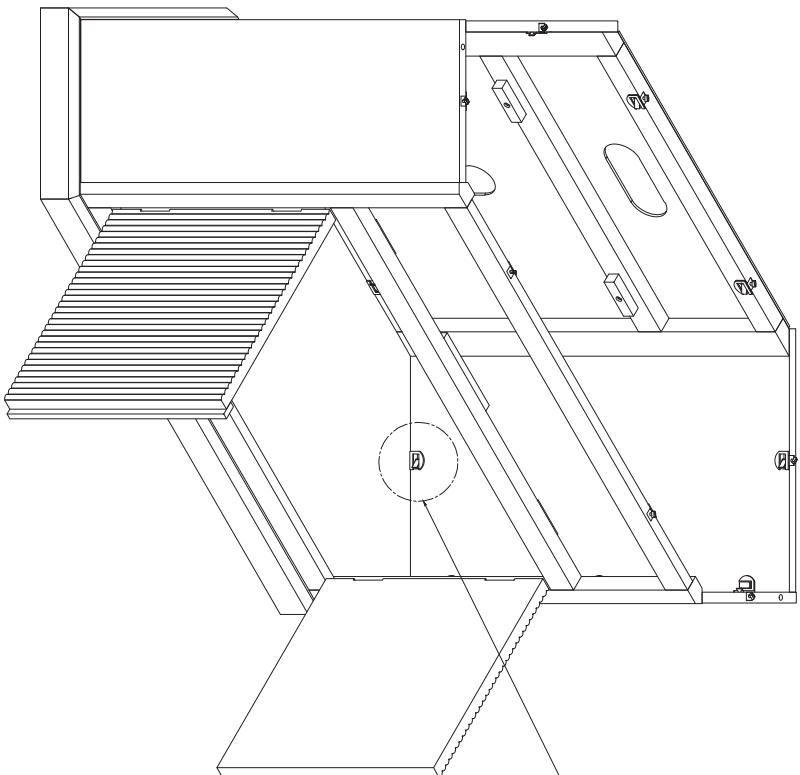

**Make sure all latches are in the locked position
before moving to next step**

6

Place Middle Shelf (C9) into position onto cleats.
Make sure part is laying flush.

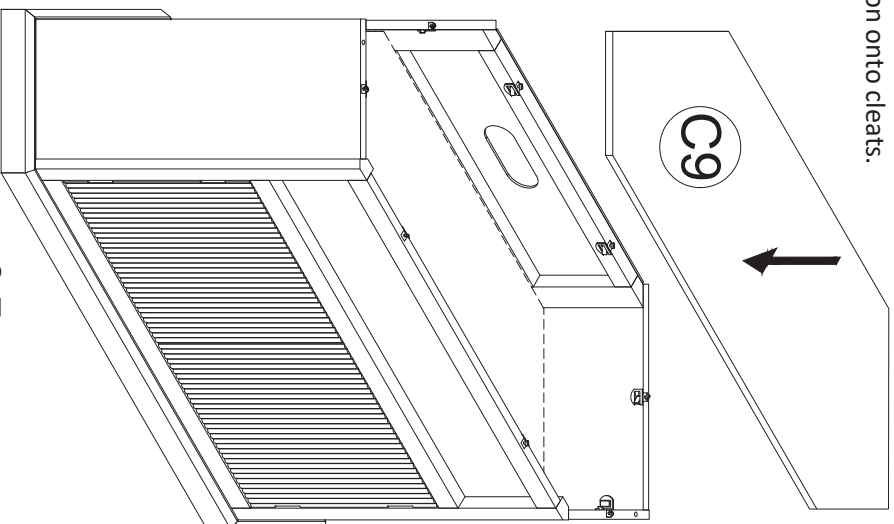

6-7

7

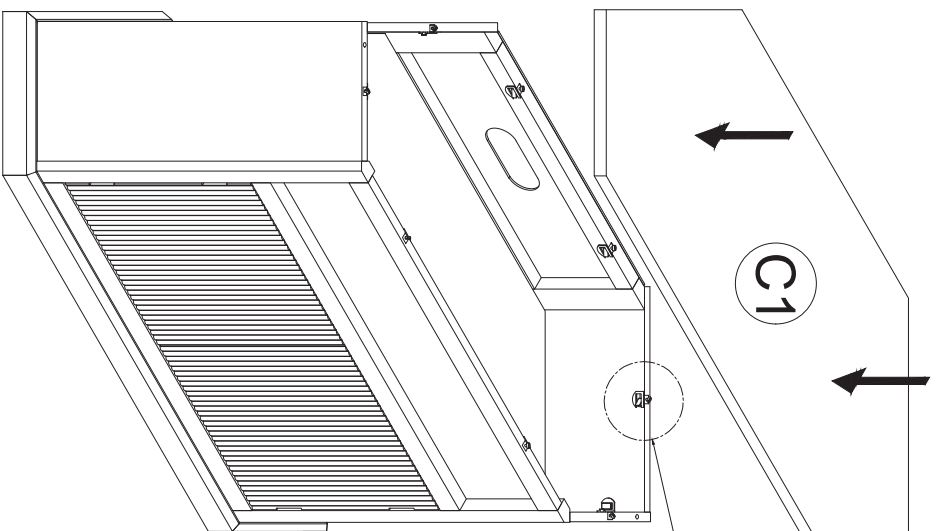

Make sure all latches are in the open position before installing Top Panel (C1)

8

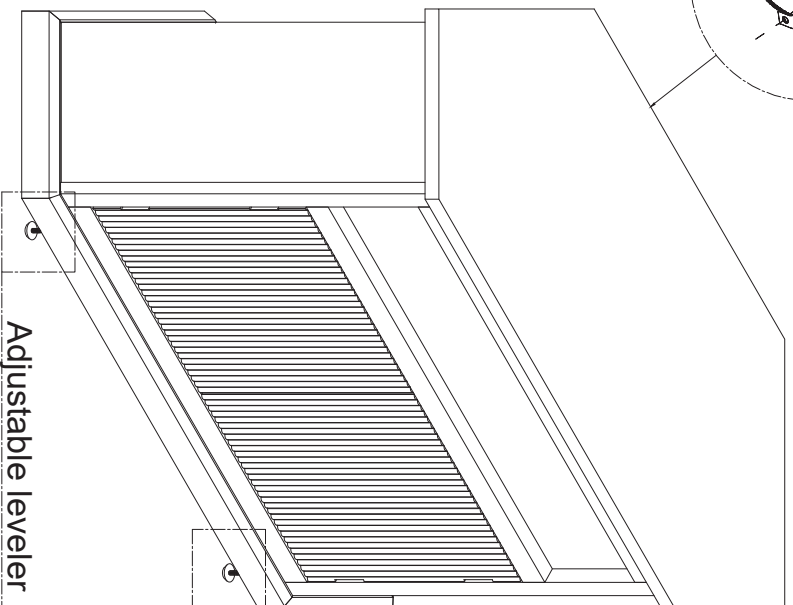
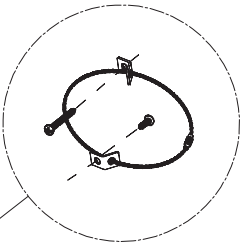

Use the leveling base to attach to the legs for balance. If the table is rocking, adjust the adjuster until the condition gets better.

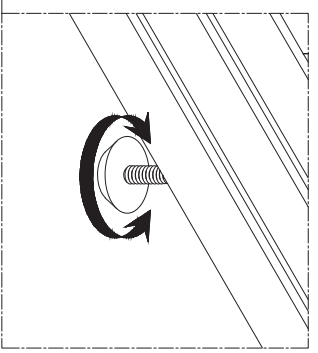

Adjustable leveler
7-7



Replacement Part Form

Have an issue? Need a replacement part?

Please E-mail us before contacting your retailer, we will be happy to fix your issue.

This process will be hassle free! We will replace your part for free!

Please follow these easy steps below.

You will need to E-mail *Martin Svensson Home Customer Service*: Customerservice@mshome.co
(Please note it is .CO not .com)

Please scan or take a picture of this form filled out.

1. **Customer Name:** _____
2. **SKU# with issue:** _____
3. **Replacement Part # needed** _____

**Please reference the Assembly Instructions to identify needed part #'s*

4. **Photos of the Damaged Part** (please include in the e-mail)
5. **Brief description of the part issue:** _____
6. **Proof of Purchase** (please provide a copy of your purchase receipt)
7. **Ship to Address:** _____

8. Other contact information:

Email Address _____

Phone # _____

**If possible, could you please provide the UPS or FedEx tracking from original shipment _____*

**If possible, could you please provide the P.O. # - information found on back/underneath product _____*

**If you have any other question, we are happy to assist with assembly questions or all other parts related questions. Thank you for your purchase!*