

Assembly Instruction

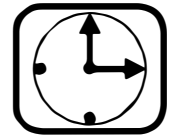

20 Mins





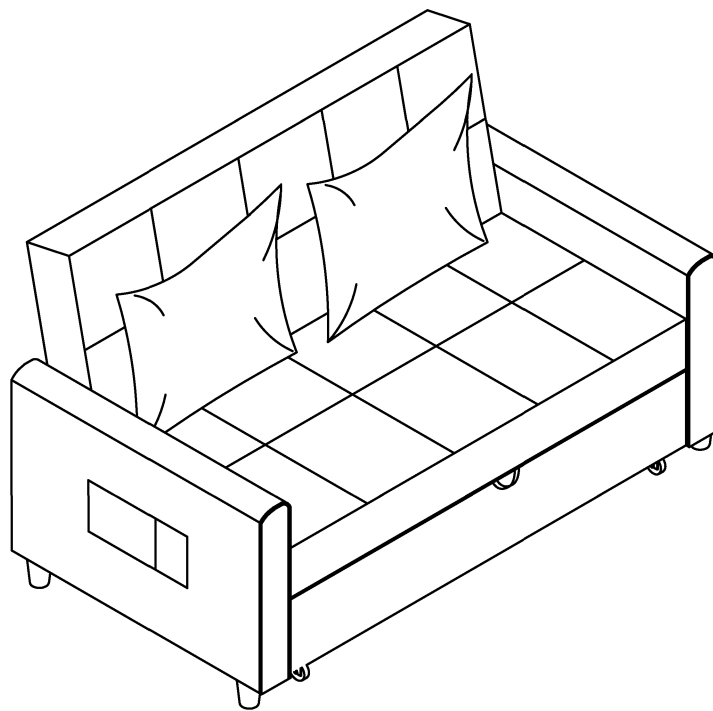

X 2



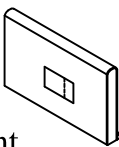
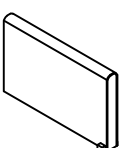
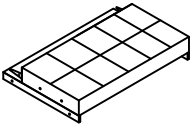
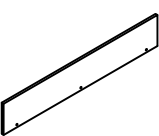
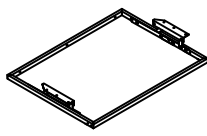
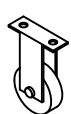

PACKING DETAILS: TOTAL 2 BOXES

BOX-1/2

BOX-2/2

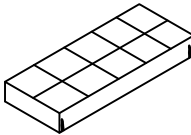
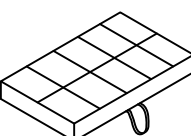



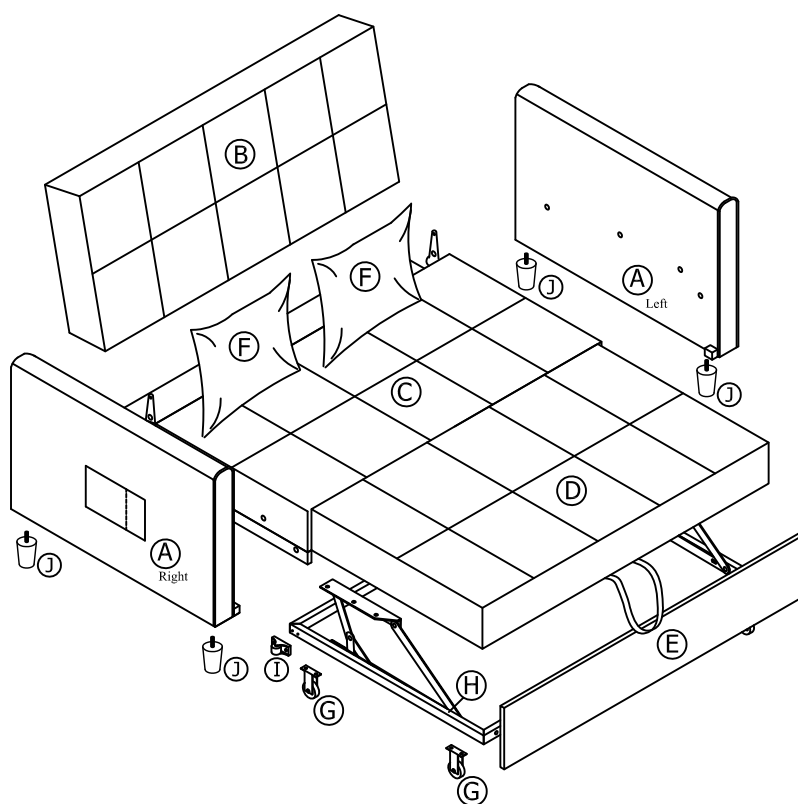





NO.	PARTS	QTY
A	 Right	1
A	 Left	1
C		1
E		1
H		1
G		4
I		2
J		4
	 Hardware Kit	1

NO.	PARTS	QTY
B		1
D		1
F		2



Please don't tighten the screws until all the screws are put into the hole. And if there is any problem, please contact us and we will help you to solve it.

Hardware List

①		Ø5/16inX2-3/4inL	8 PCS	②		Ø5/16in	11 PCS
③		Ø5/16inXØ7/8in	11 PCS	④		Ø1/4inX3/4inL	12 PCS
⑤		Ø1/4in	12 PCS	⑥		Ø1/4inXØ5/8in	12 PCS
⑦		Ø1/4in	1 PC	⑧		Ø5/16in	1 PC
⑨		Ø5/16inX1-1/2inL	3 PCS	⑩		Ø5/32inX3/4inL	4 PCS

A

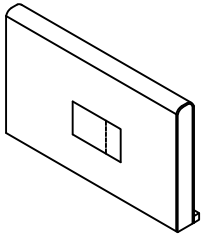

Right 1pc

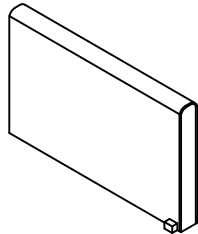

Left 1pc

B

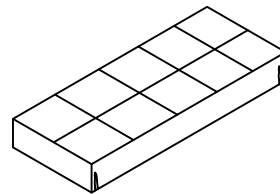

1 pc

C

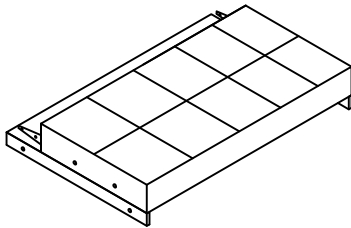

1 pc

D

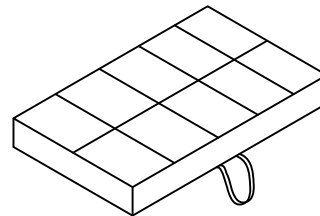

1 pc

E

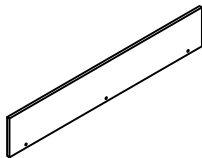

1 pc

F



2 pcs

G

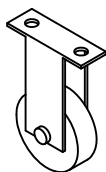

4 pcs

H

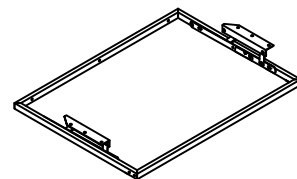

1 pc

I

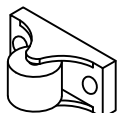

2 pcs

J



4 pcs

Assmbly Instructions

1

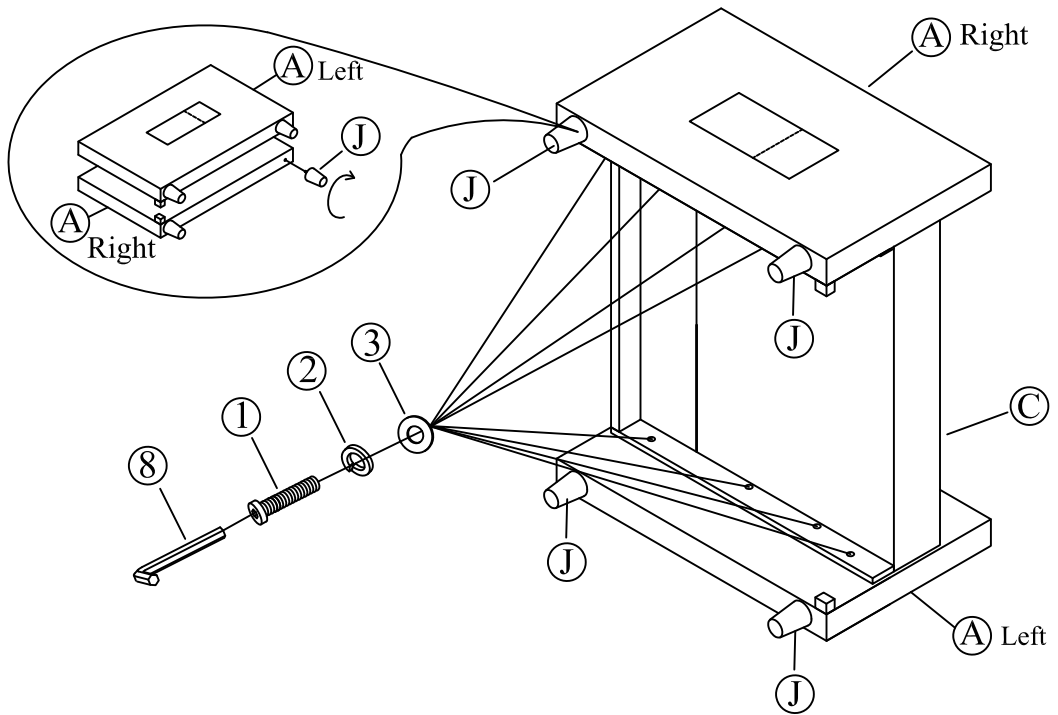
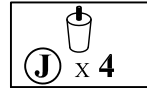
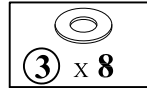
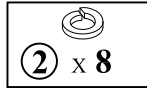
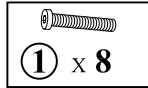
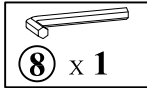

2

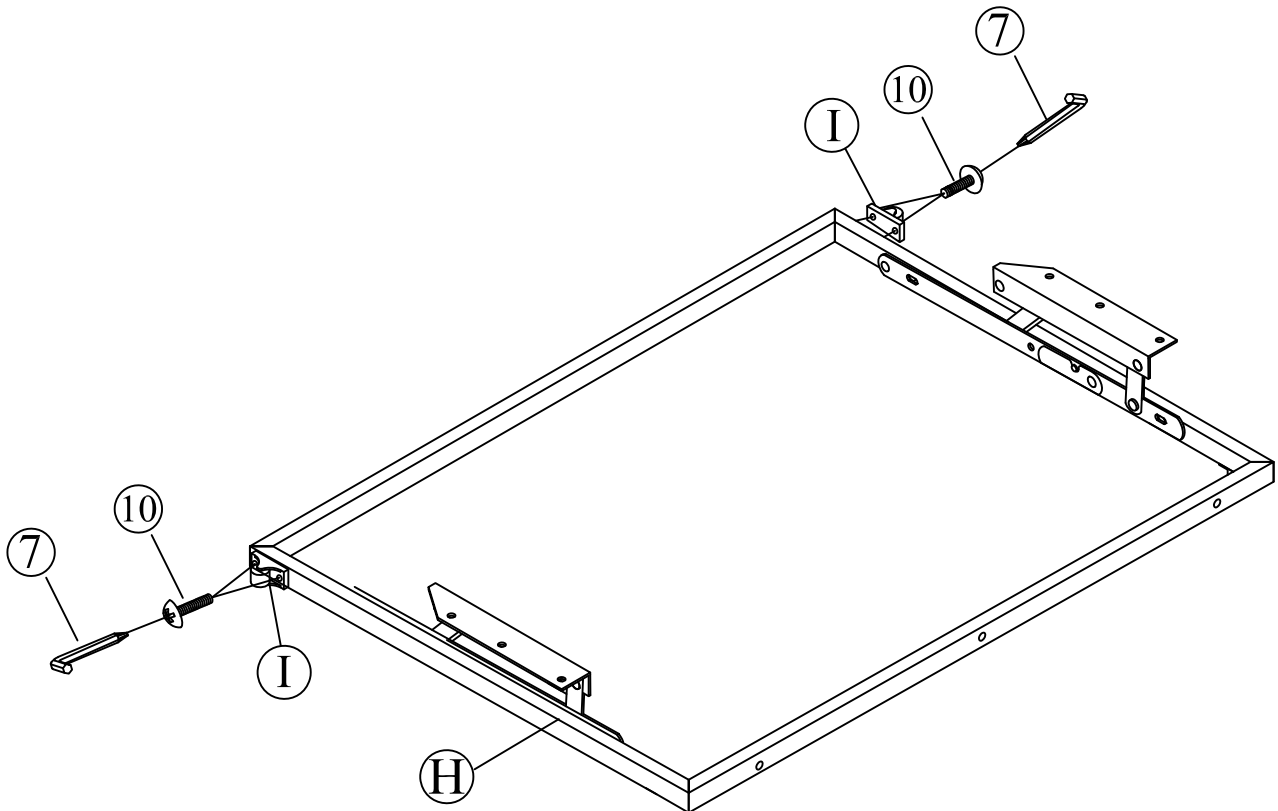
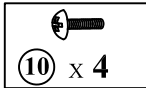
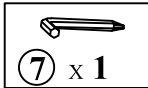

Assembly Instructions

3

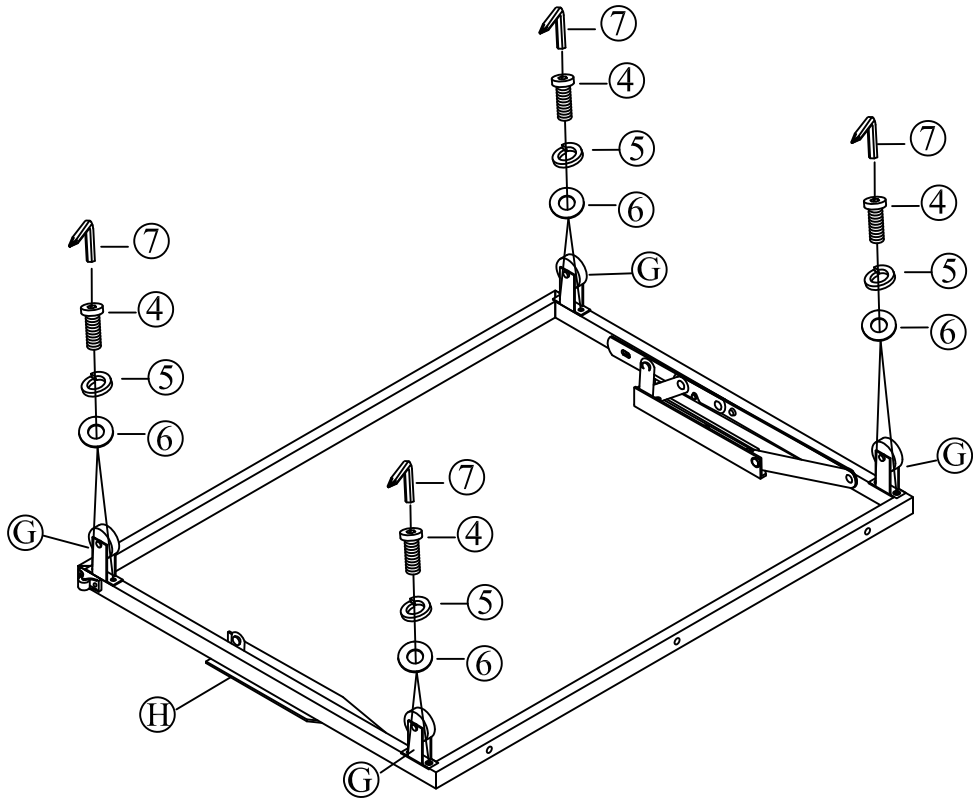
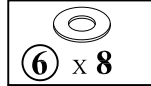
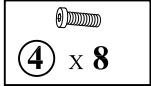
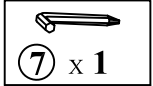

4

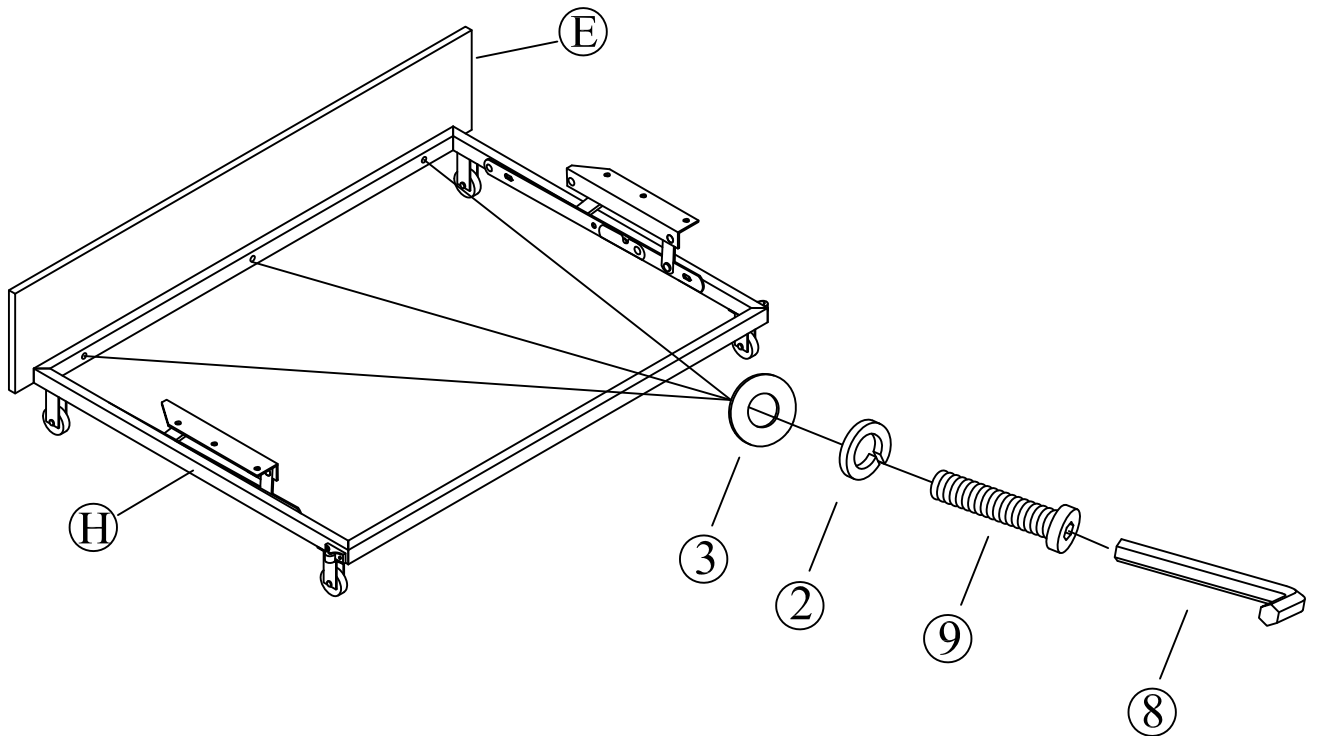
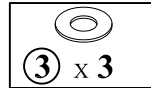
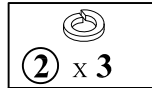
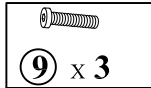
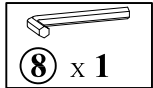

Assmly Instructions

5

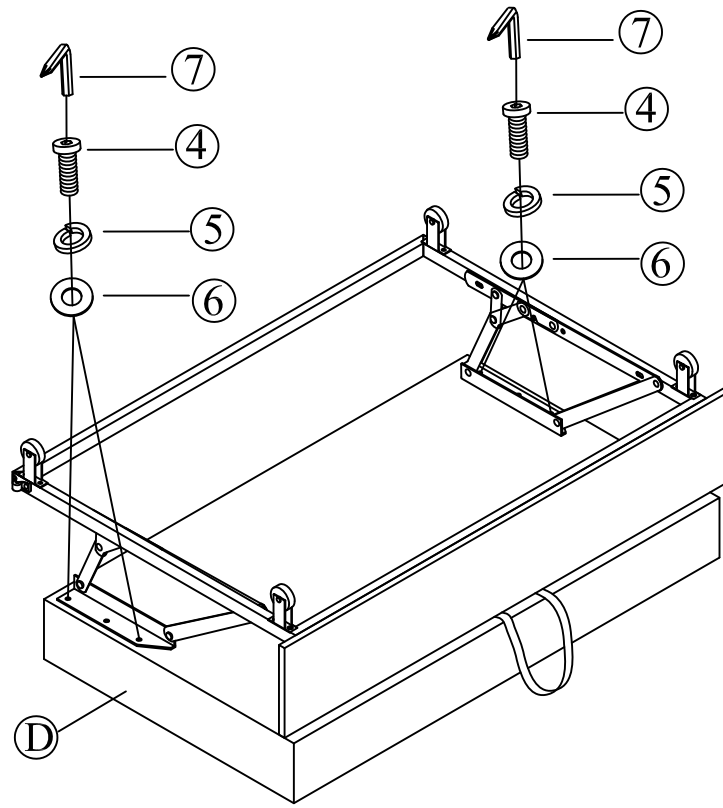
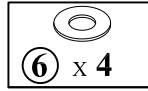
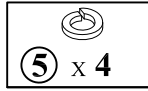
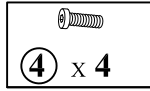
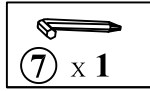

6

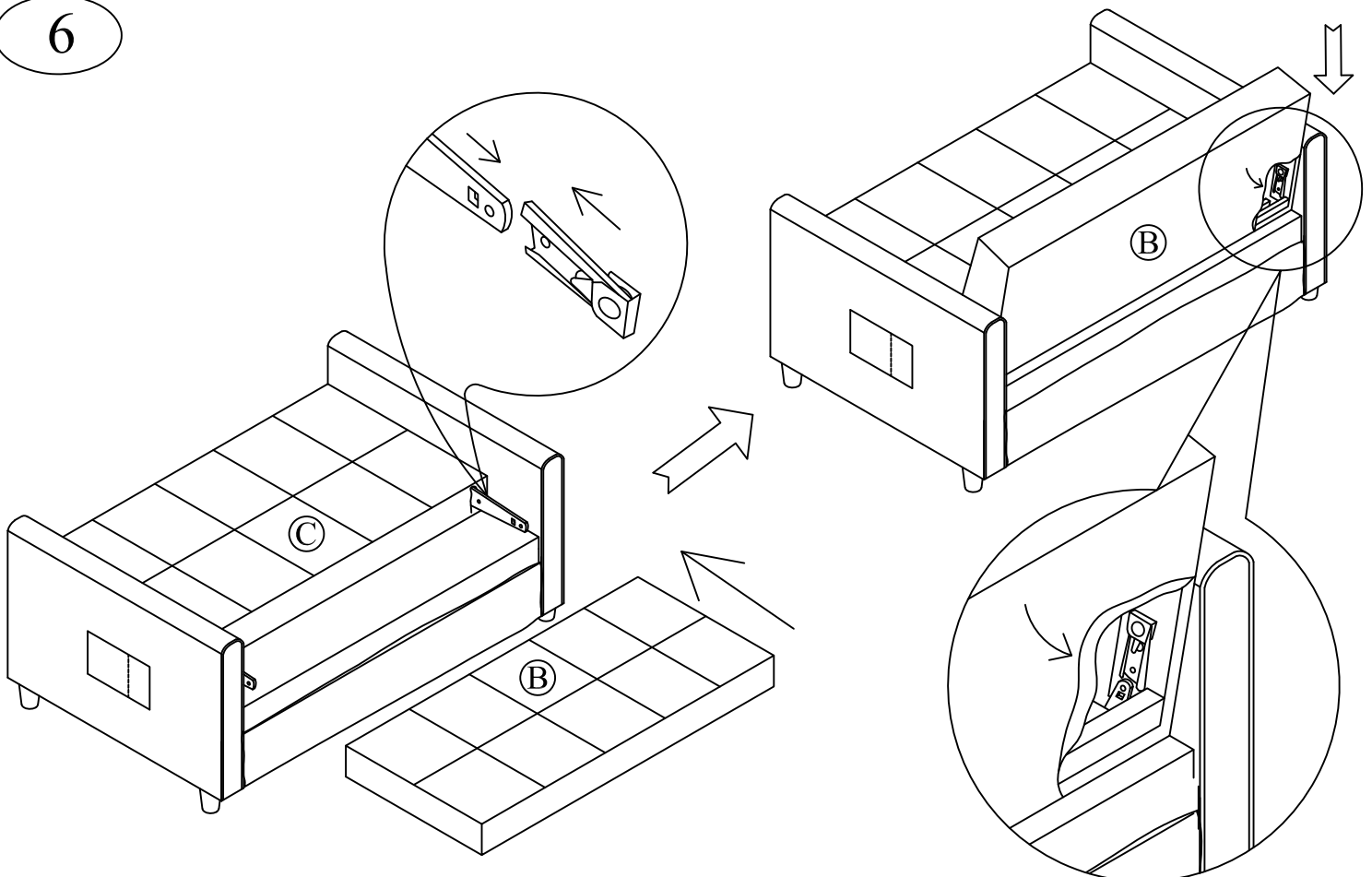

Assmby Instructions

7

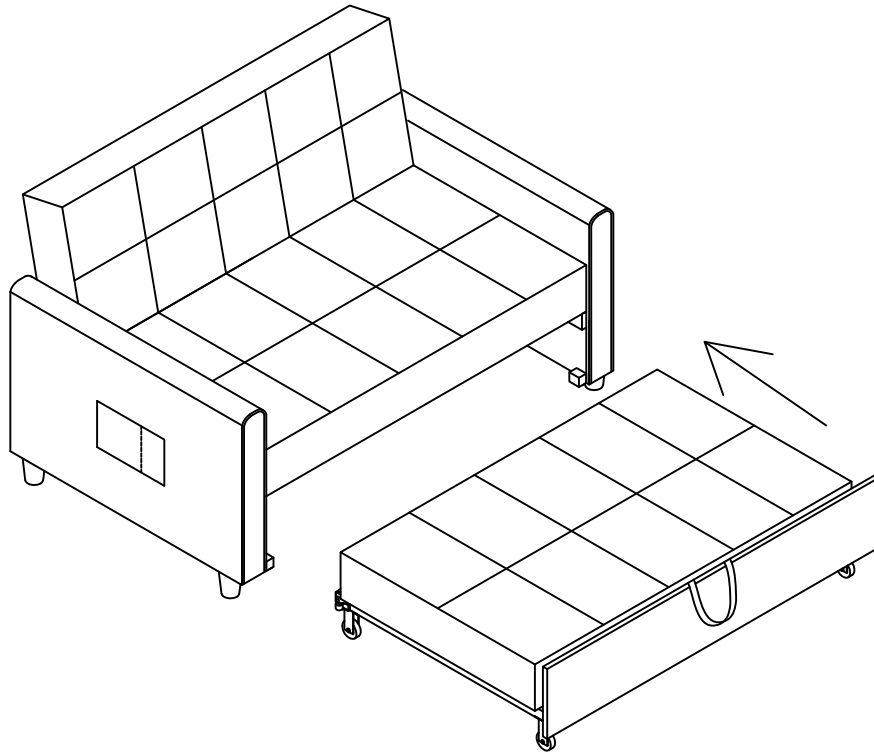

8

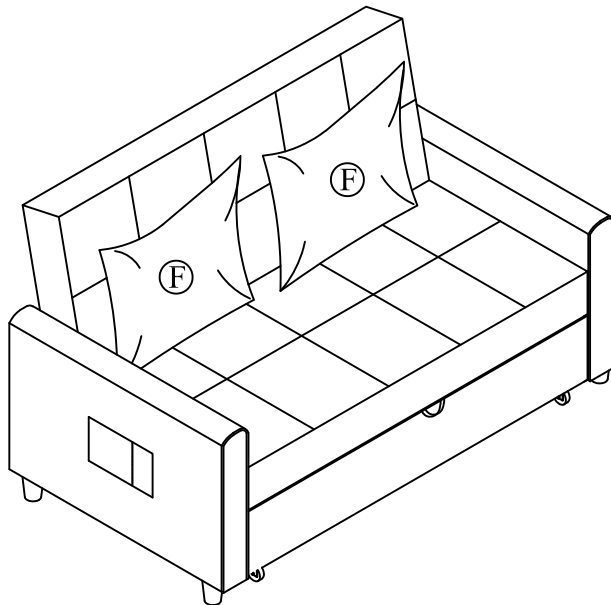

Assmly Instructions

Way to Adjust the Backrest

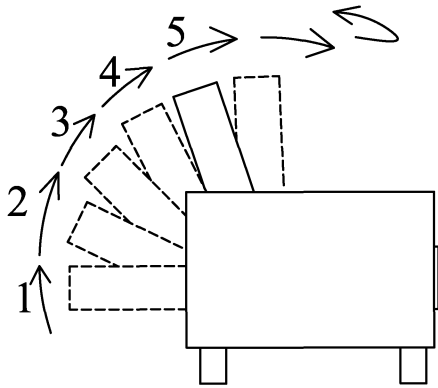

From the bottom to the top:
Put it flat and lift it once: for first gear
Up again: second gear
Lift it up again: third gear
Put it up again: fourth gear
Up again: Back to flat

Way to Adjust the Footrest

