

Assembly Instructions







Caution: You must read this before you proceed

Dining Chair





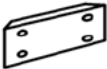

WARNING: These chairs are intended only for normal use with all four legs on the ground. These chairs have relatively thin legs and are not designed to be sat in with only two legs on the ground (as from tipping back, forward, or to the side), and such can cause stress and failure of one or more of the legs. Any misuse of the chairs voids any warranties, expressed or implied.

Part List

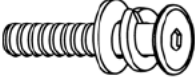
Label	Picture	Description	QTY
A		Leg (Labelled 'A')	1
B		Leg (Labelled 'B')	1
C		Backrest	1
D		Cushion Seat	1
E		Corner Block (Side)	2
F		Corner Block (Front)	1

Hardware

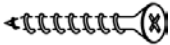
Label	Picture	Description	QTY
①		JCBC M6 x 25mm + S/W M6 + F/W M6 x 13mm	5
②		JCBC M6 x 70mm + S/W M6 + F/W M6 x 13mm	5

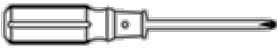
③		JCBC W Screw (M7 x 50mm)	2
④		FH Screw (#8 x 25mm)	13
⑤		Allen Key (M4)	1
⑥		Screwdriver	Not provided

Assembly Preparation

Before Beginning Assembly:

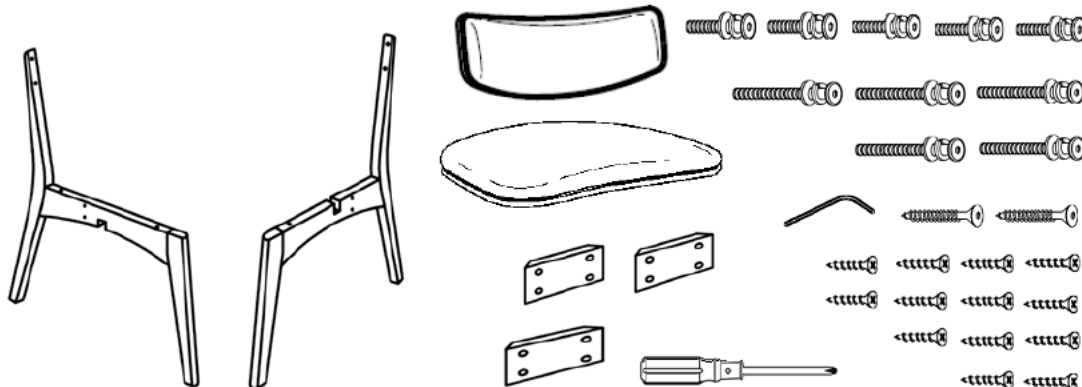

- Read instructions, cover to cover-



- Have 2 adults on hand for assembly-



- Do not assemble on flooring or carpet-



- Assemble on a clean non-marring surface (packing foam)-



- Save all packaging until finished-

Assembly Steps

Overview

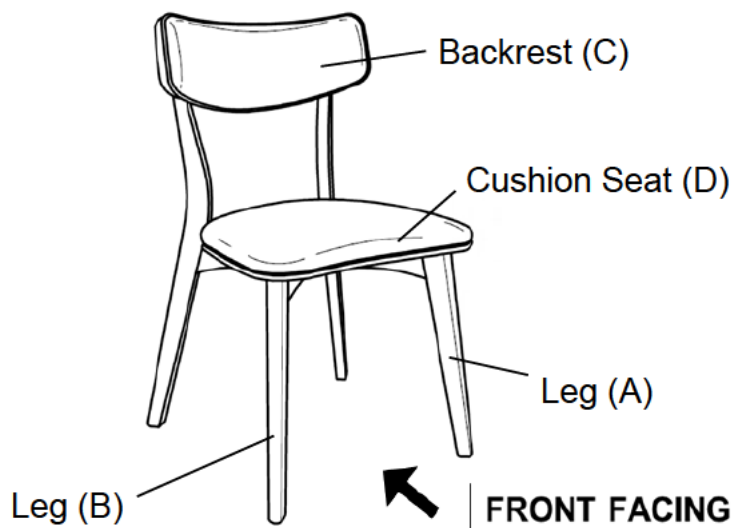

This Dining Chair has multiple parts and may require up to 30 minutes to assemble. To give you an overview of the Dining Chair parts, the above picture is to help you put the various parts into perspective. Please read through the instructions below to familiarise yourself with the parts and steps before assembly.

Step 1

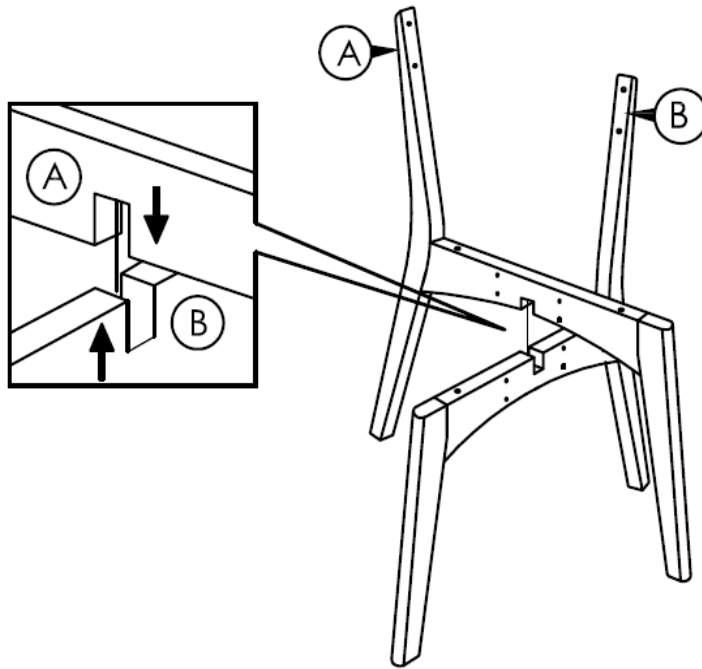

Crossover and join Leg(A) into Leg(B) as shown above.

Step 2

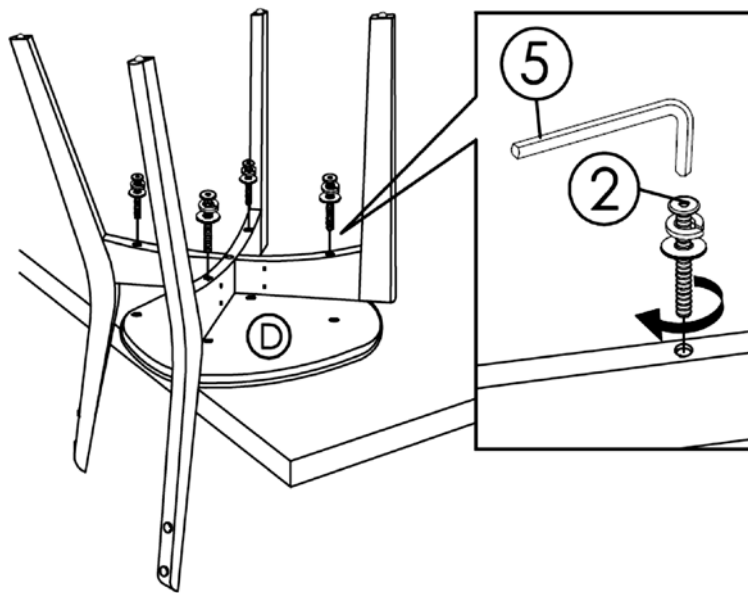

Place Seat Cushion(D) facedown on the edge of a table top as shown.
Align Leg(A) and Leg(B) to Seat Cushion(D) as shown above.
Attach Leg(A) and Leg(B) to Seat Cushion(D) using JCBC Bolts(②) with Allen Key(⑤).
Do not fully tighten the Bolts.

Step 3

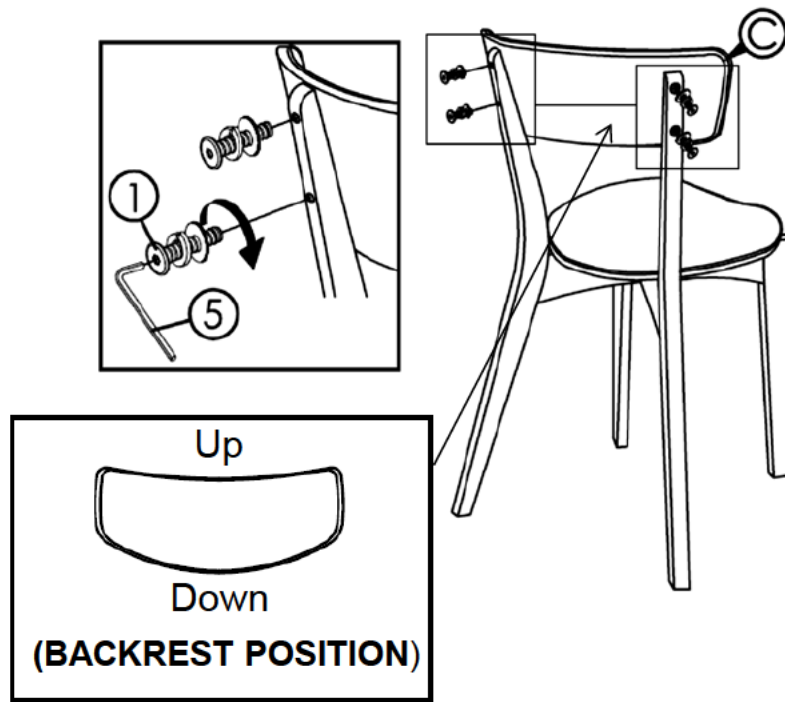

Align the Backrest(C) to Leg(A) and Leg(B) as shown above.
Attach Backrest(C) to Leg(A) and Leg(B) using JCBC Bolts(①) with Allen Key(⑤).
Do not fully tighten the Bolts.

Step 4

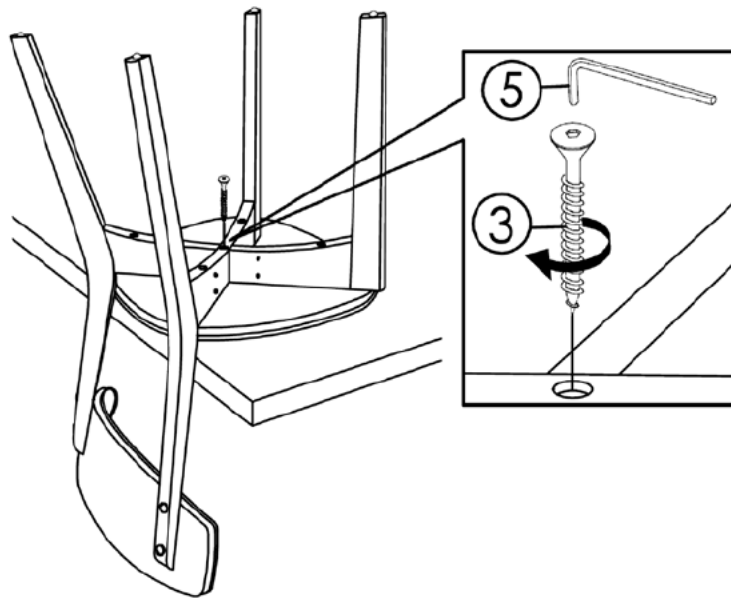

Attach Leg(A) to Leg(B) using JCBC Screw(③) with Allen Key(⑤) as shown.
Do not fully tighten the Screw.

Step 5

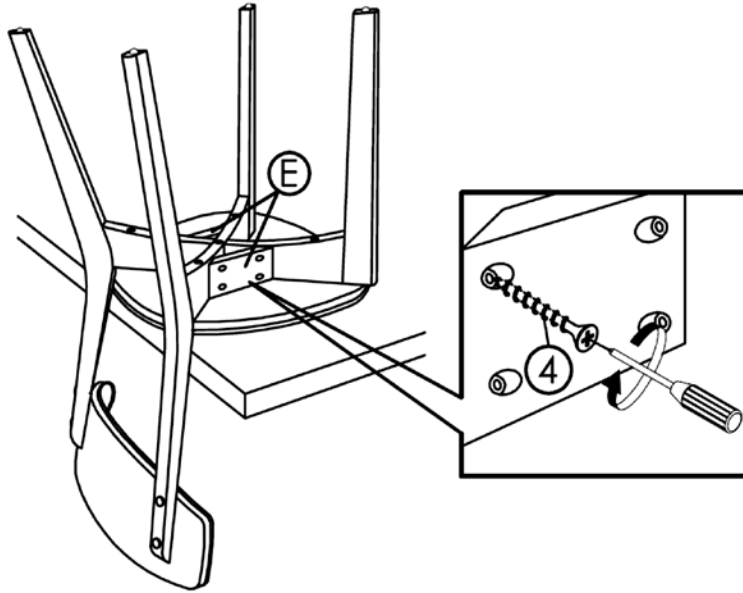

Place the Corner Block(E) at the side joint of Leg(A) and Leg(B) as shown.
Attach Corner Block(E) to Leg(A) and Leg(B) using Screws(4) with Screwdriver(6).
Do not fully tighten the Screws.
Repeat this process with the other Corner Block(E).

Step 6

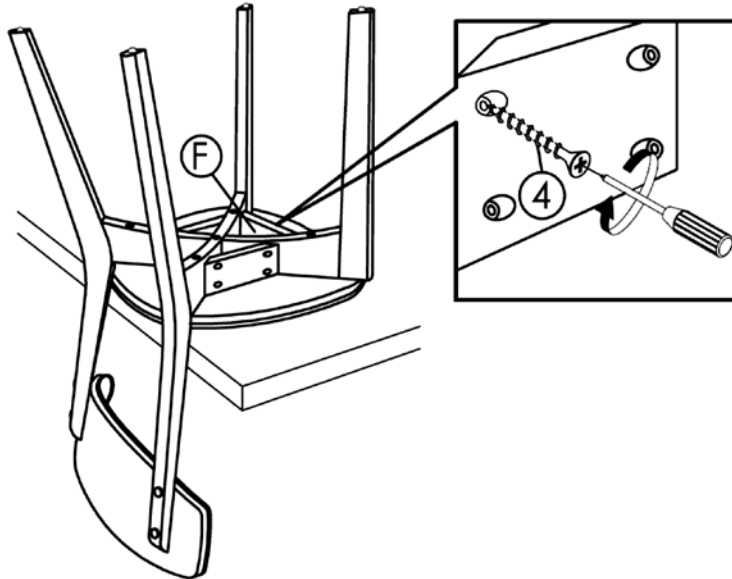

Place the Corner Block(F) at the front joint of Leg(A) and Leg(B) as shown.
Attach Corner Block(F) to Leg(A) and Leg(B) using Screws(4) with Screwdriver(6).
Do not fully tighten the Screws.

Step 7

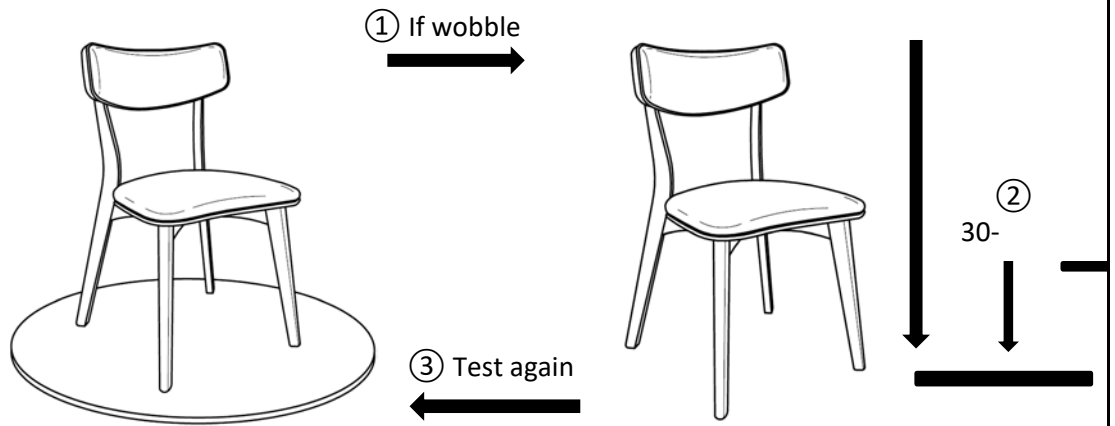

Place the Dining Chair on a Level Surface to check if it wobbles.

Lift the Dining Chair some 30mm to 50mm high from the ground, keep your feet and toes well away from the drop zone, and drop the Dining Chair freely and vertically with the four legs, hitting the ground at the same time.

This Drop Test will help to ensure that all the Parts, Bolts, and gaps reach full alignment.

Test again for evenness on Level Surface.

If no wobbles are found, proceed to tighten all the Bolts and Screws.

When tightening the Bolts and Screws, tighten sequentially.

Do not tighten any Screw or Bolt fully and then move on towards the next one, this could cause the frame to warp.

If the Dining Chair still wobbles, loosen the Bolts and execute this same drop test.

If the Dining Chair is not stable it could lead to damage to the product.

Step 8



Your Dining Chair is ready for use.

This Dining Chair can only be used on a flat, level surface.

Care & Maintenance



- Furniture may scratch floors. We recommend using furniture pads to protect your floors.



- Do not put hot items directly on furniture surface.



- Do not clean furniture with harsh cleansers or polish.



- Do not place furniture under direct sunlight.



- Do not place furniture near heating or cooling vents.



- Do not write on furniture without a padded barrier to protect the surface.



- Do not place furniture outside . For indoor use only.



- Not for commercial use. For residential use only.



- Stains may be removed with mild soap solution and damp cloth.



- Children should not climb or jump on the furniture.



- Dust and pick-up spills using a clean, non-colored, lint-free cloth.